

# 42129 4X4 Mercedes Benz Zetros Trial Truck LED lighting Kit (Standard style) LG76/GC76

**Instructions for installing this kit:**

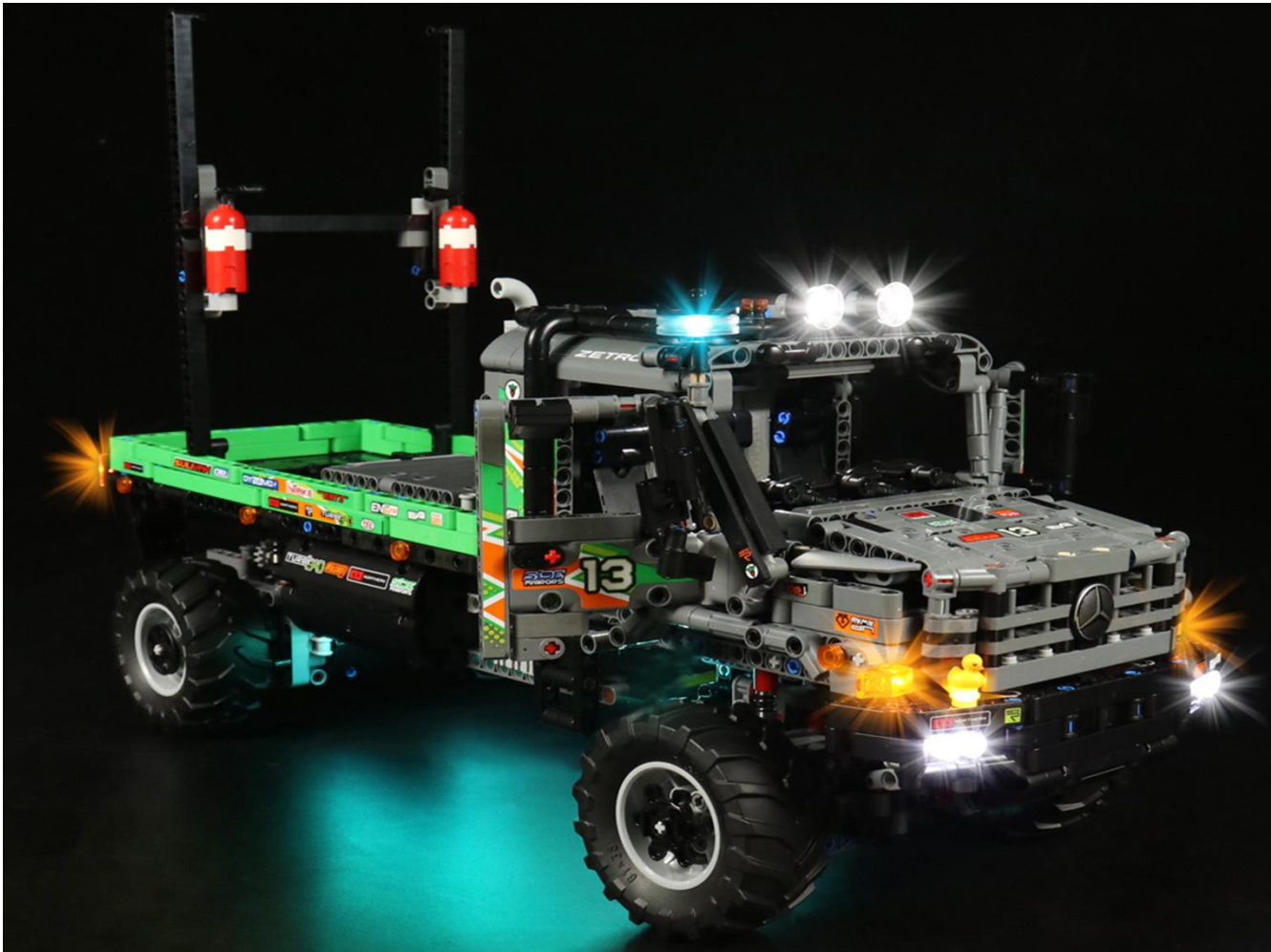

**Power supply mode: USB power cord (please bring your own power supply).**

It can be energized through a USB battery box (please pay attention to the positive and negative poles of the battery), power bank, mobile phone charger or USB socket. The normal voltage is 3-5V.

# USB connectors to connect devices

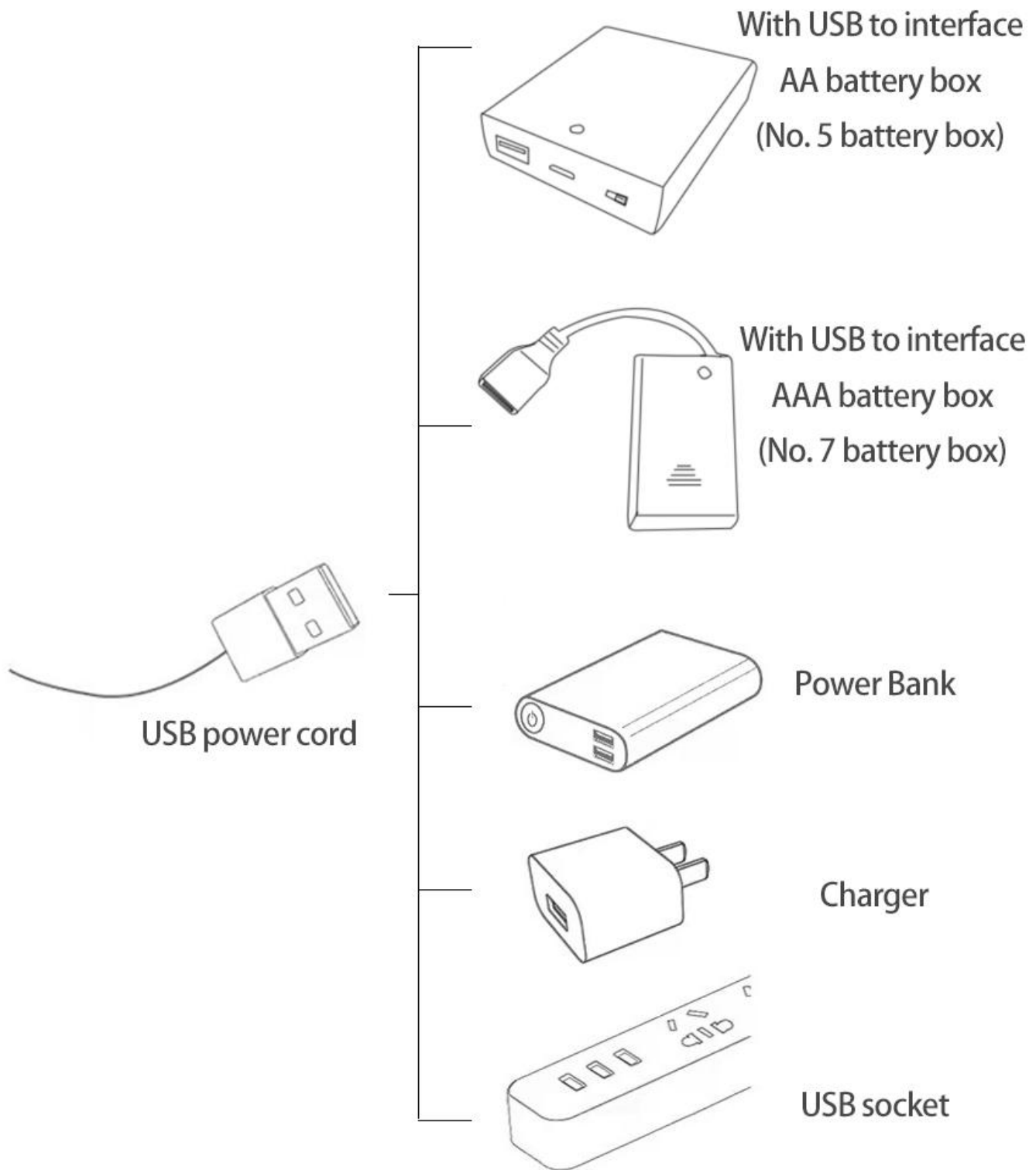

There are 5 bags of this product, and the No. 7 battery box is a gift. (Without battery)



### Lighting test:

Take out the parts in the No. 4 and No. 5 bags.

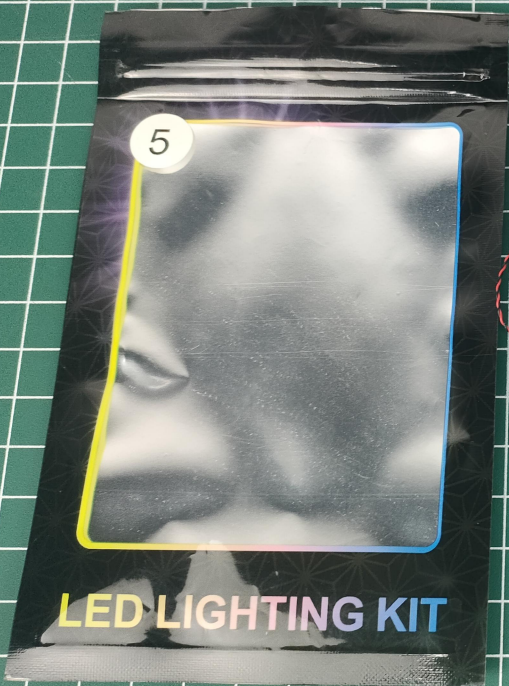

Take out the battery box and expansion board separately.



Lift the seal on the expansion board.

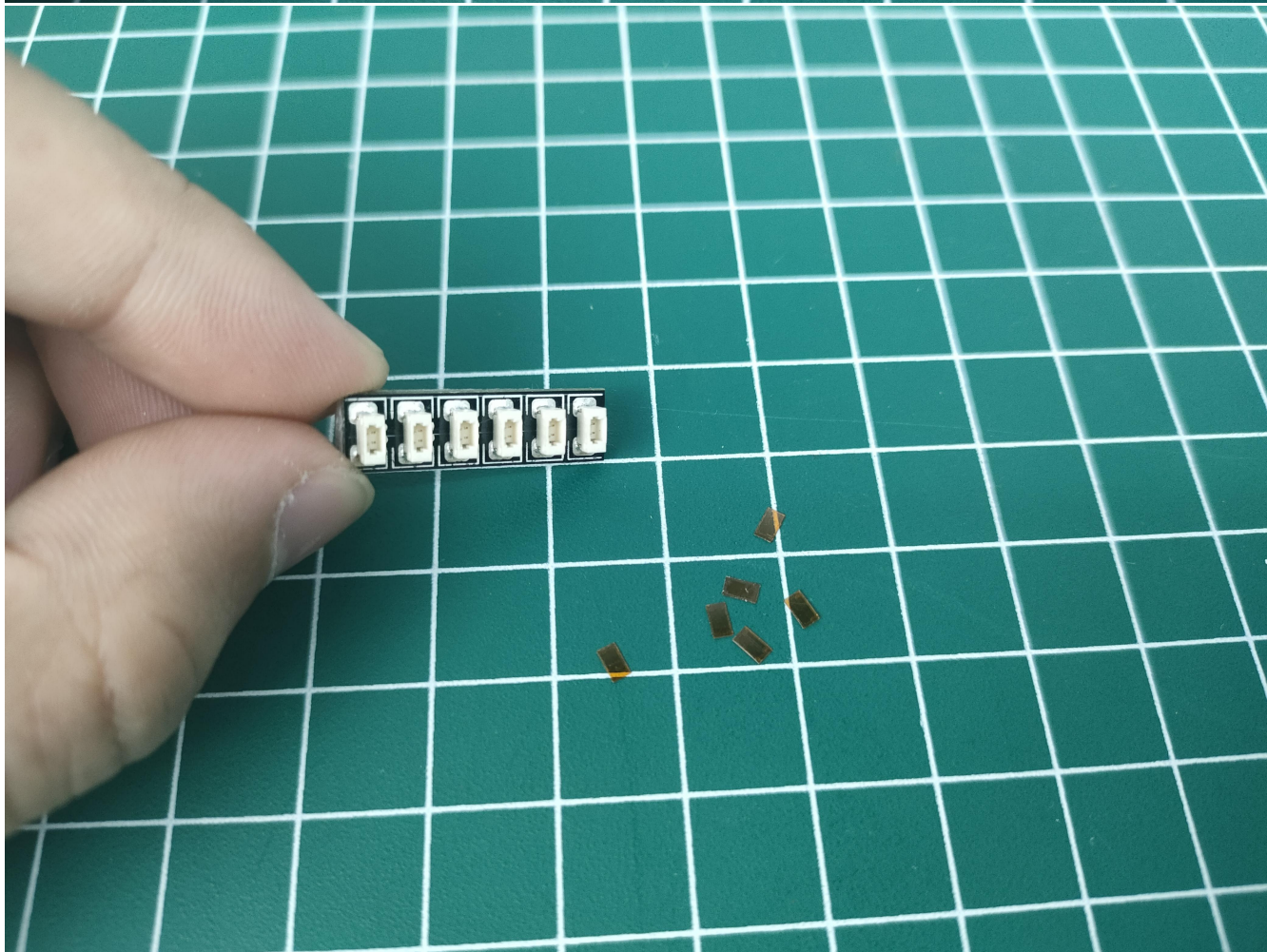
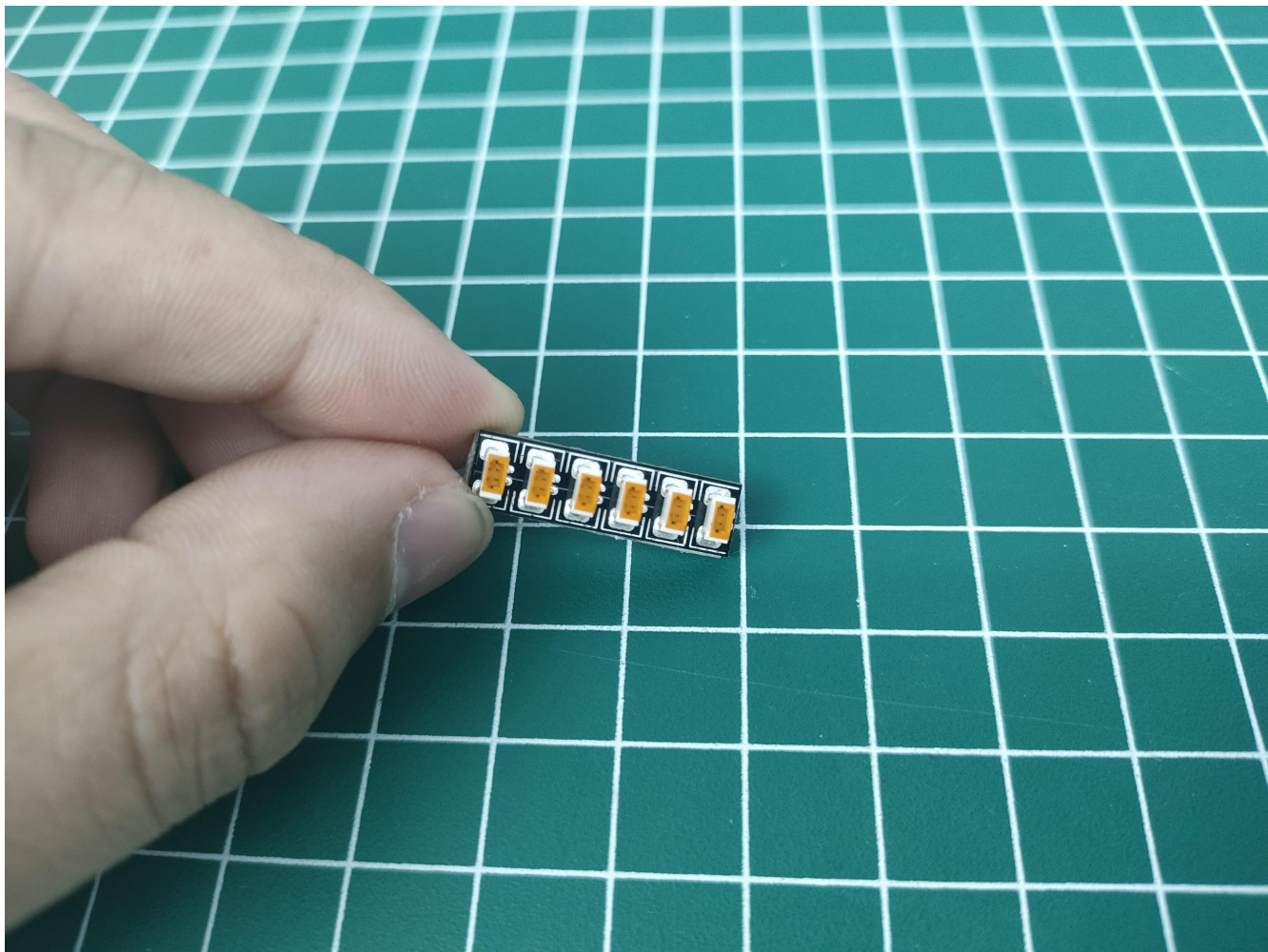

Please pay attention to the way the interface is used. The interface is small, please use it carefully: the = sign of the 2P interface is aligned with the = sign of the expansion board.

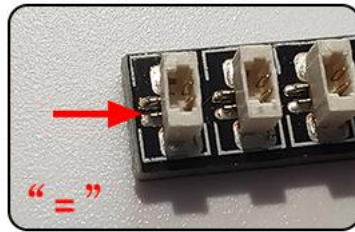
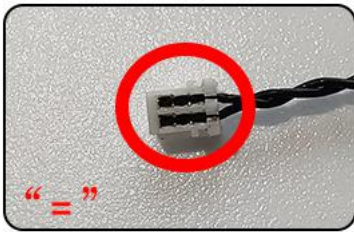

The battery box is connected to the expansion board.

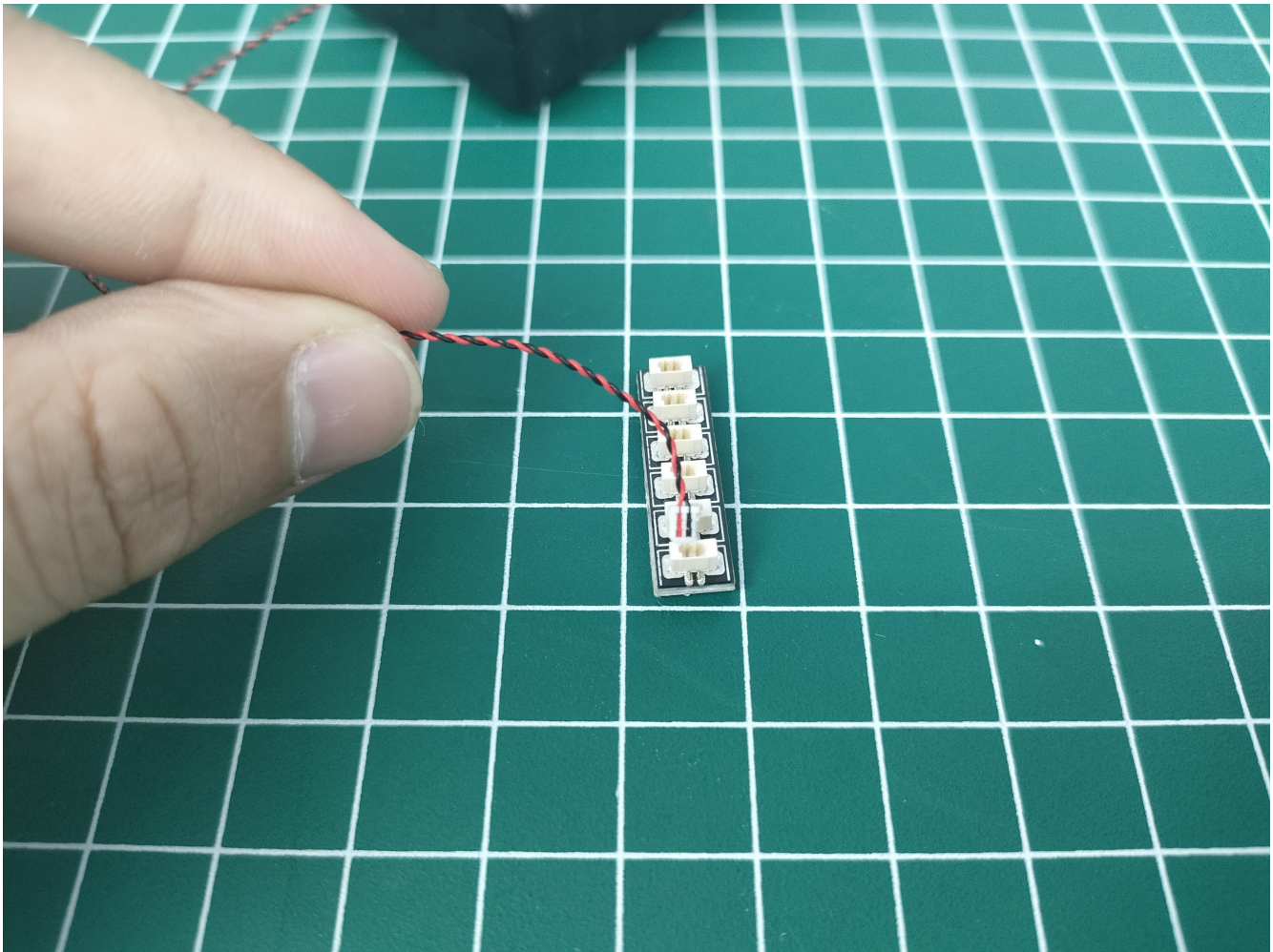

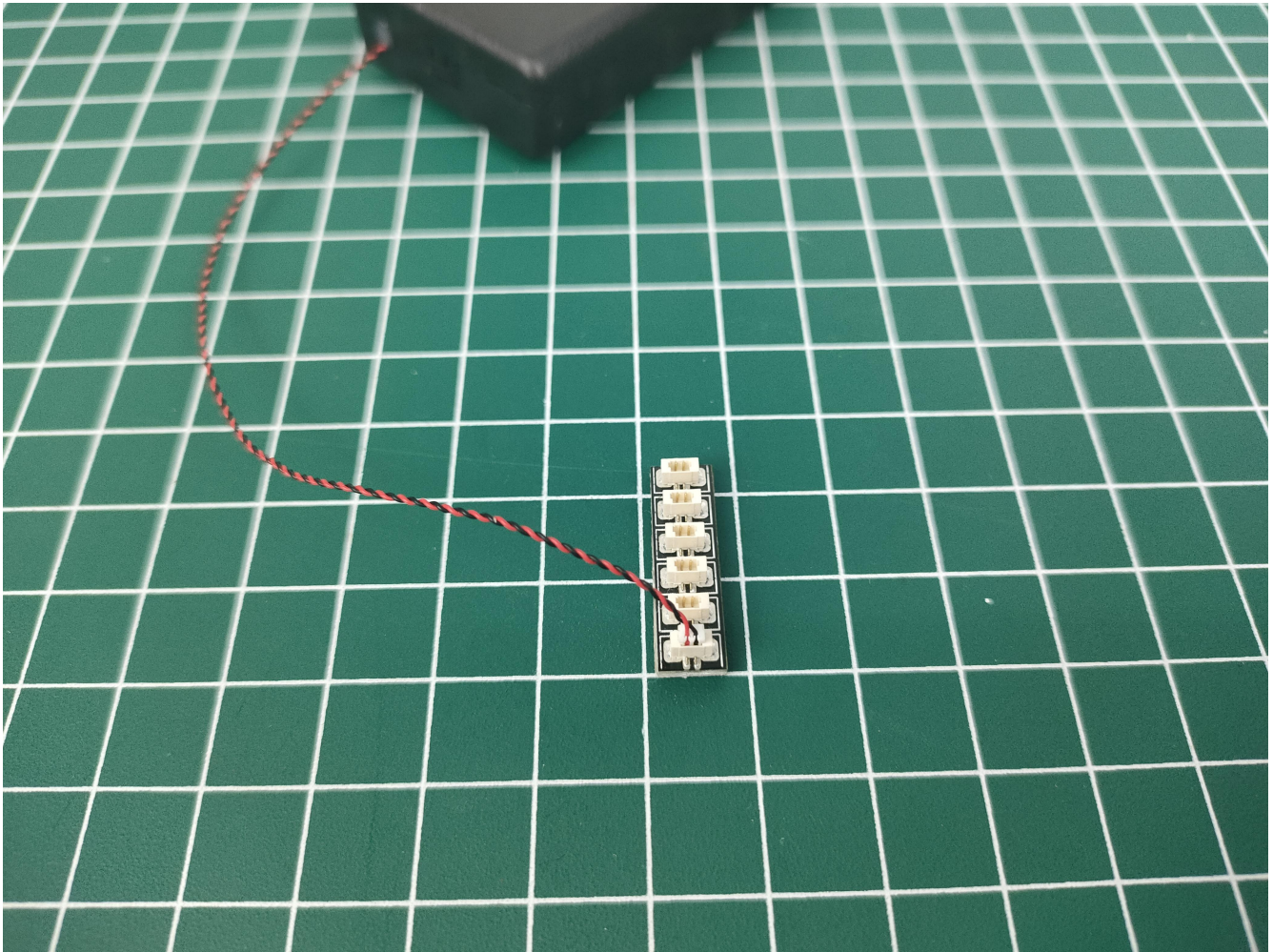

Open the battery box cover, install the battery, pay attention to the positive and negative poles.



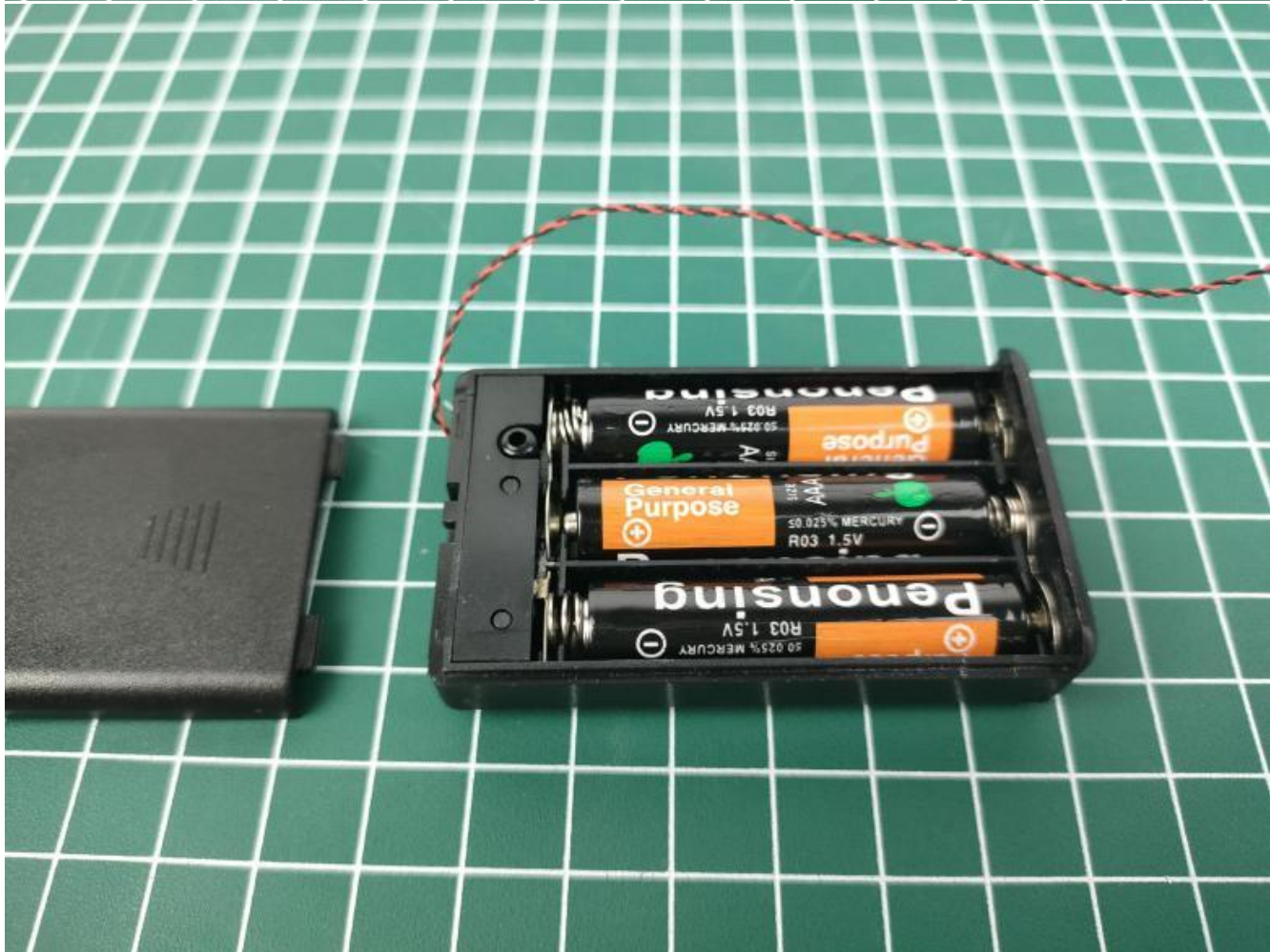
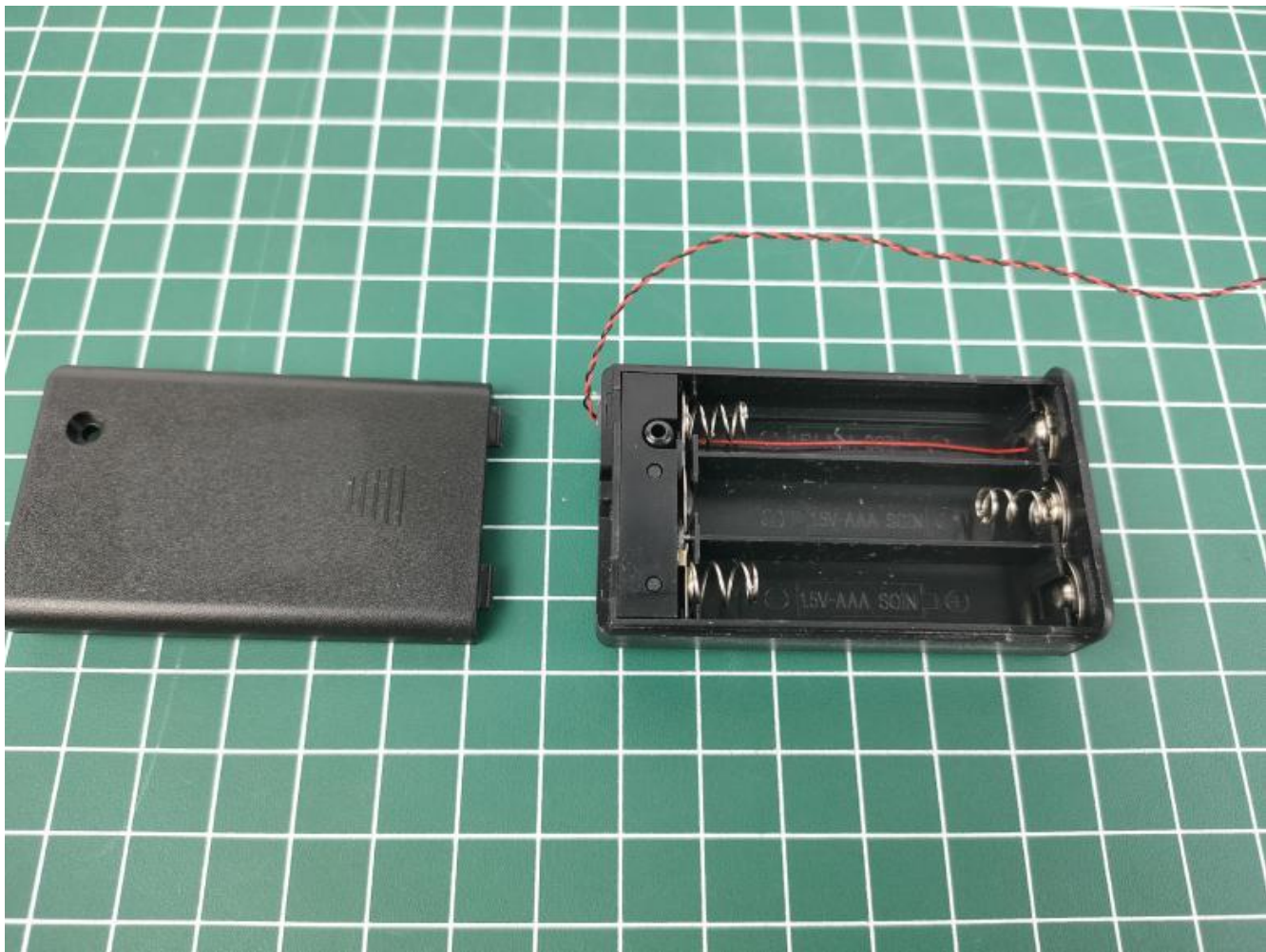

Close the battery compartment cover.



Take out the lighting from the No. 1 bag.



Connect it to the expansion board.

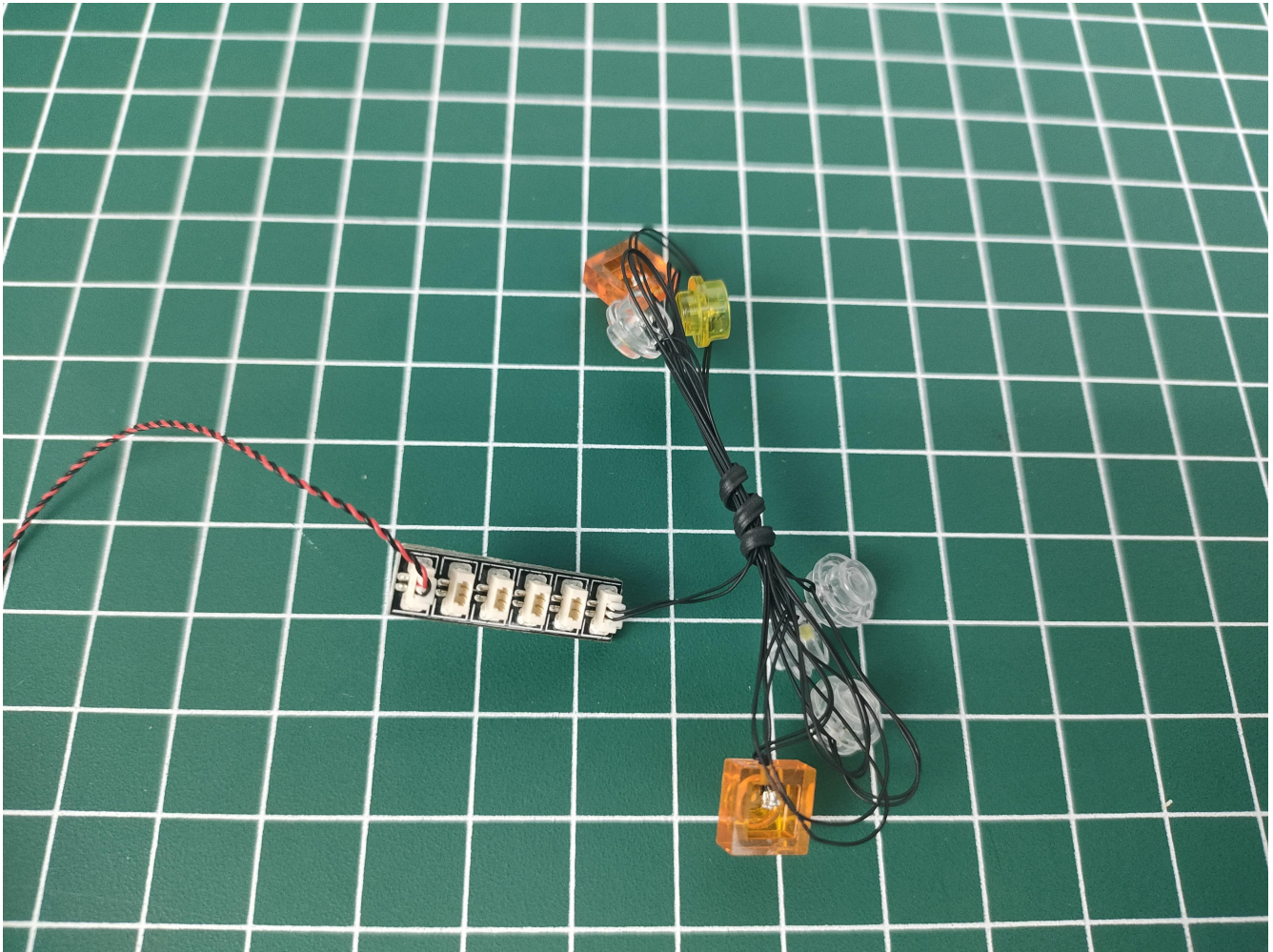

Turn on the switch on the battery box.



Test whether the lighting is normal, if there is any abnormality, please contact us in time.

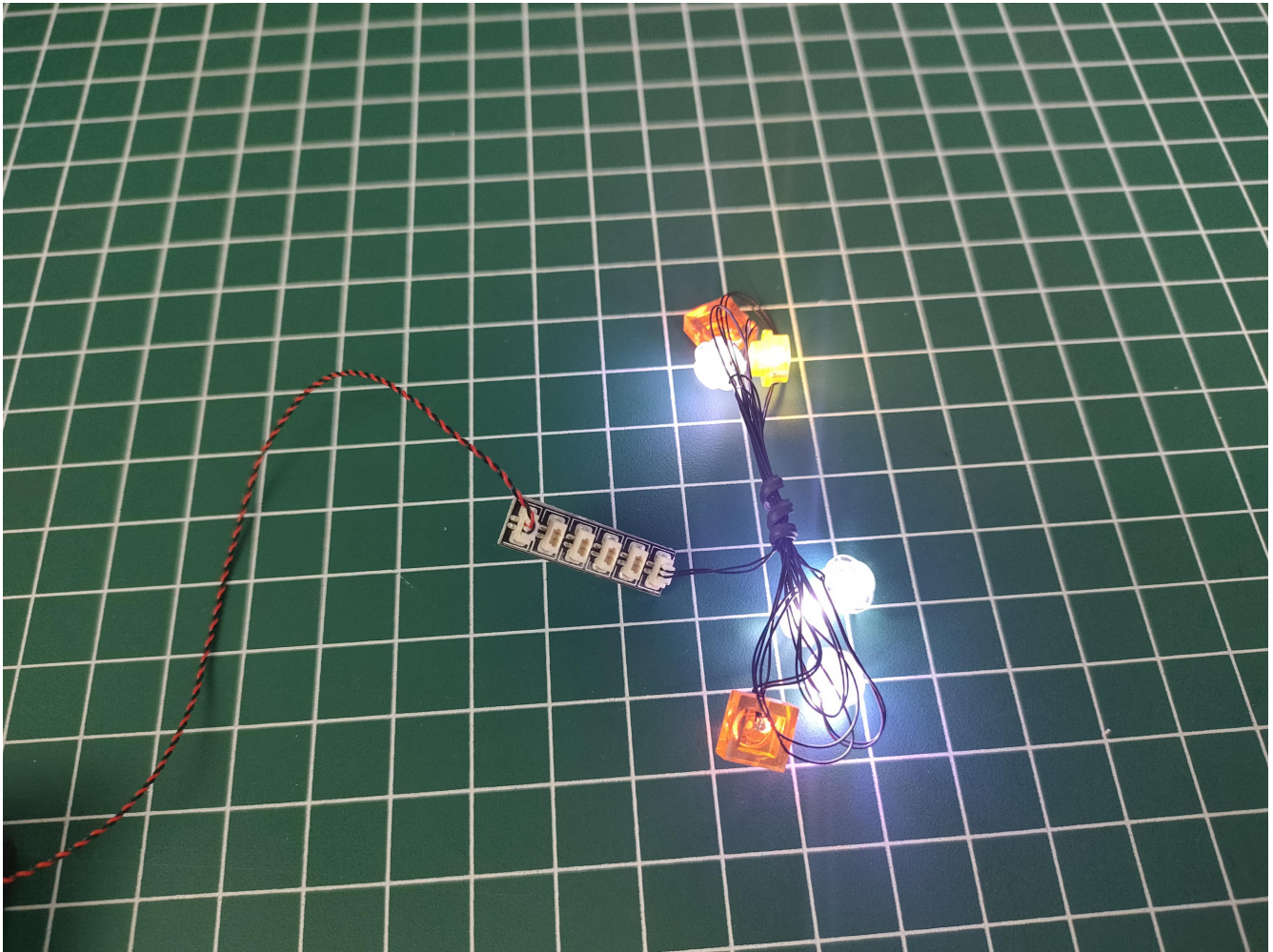

After there is no abnormality, unplug the lighting from the expansion board.

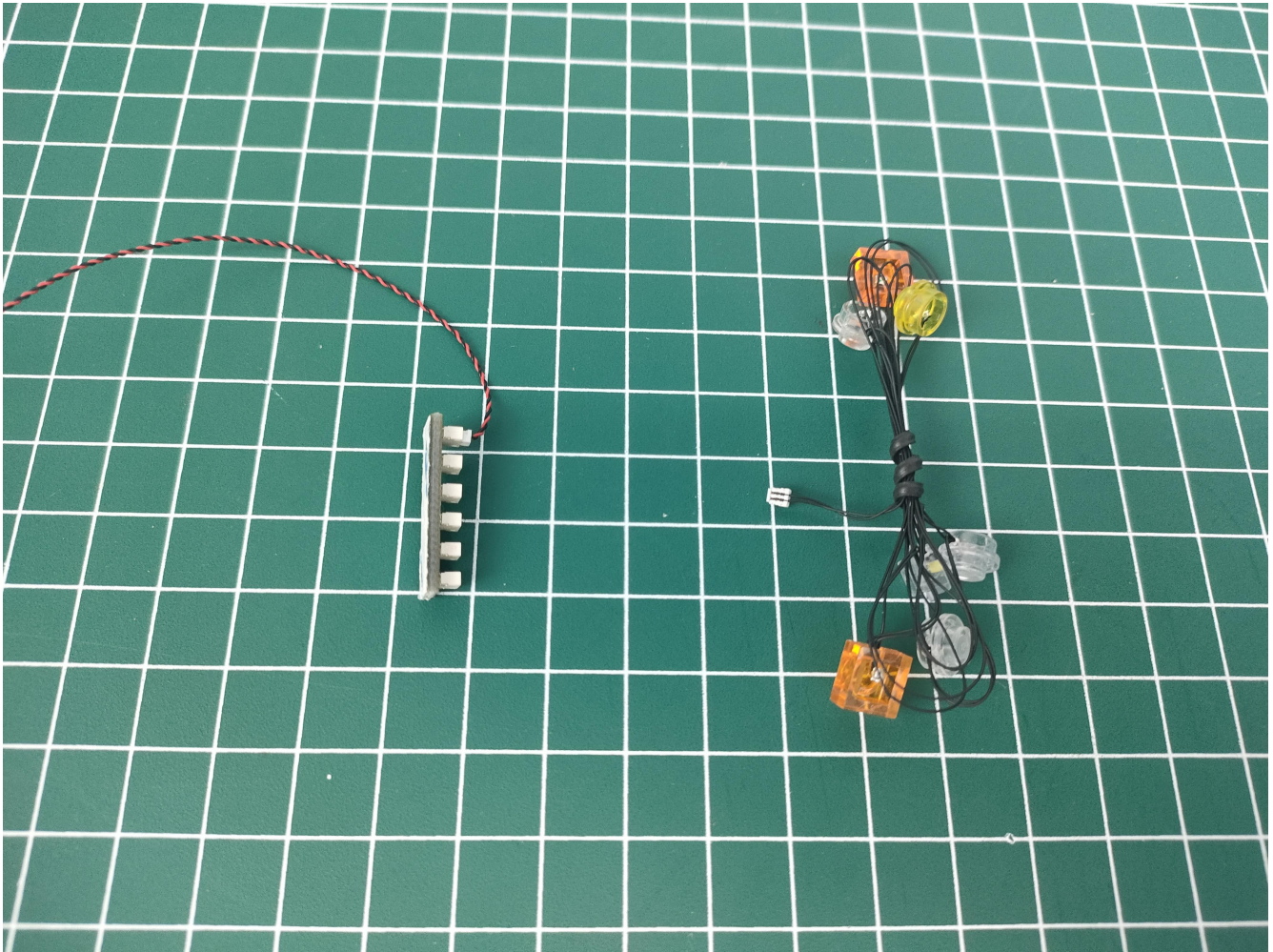

To avoid losing and mixing up the lights, put them back in their original bags first.



In order to prevent the lighting from not bright after installation, the lighting in other bags are also tested in the same way. After testing a bag, please temporarily put it back in the original bag to avoid confusion with each other.





The picture shows the USB power cord. Its usage is similar to that of a battery box. You can use a power bank or mobile phone charger to supply power. See above for details. The battery box and USB power cord can be freely selected (the battery box is used in this article).

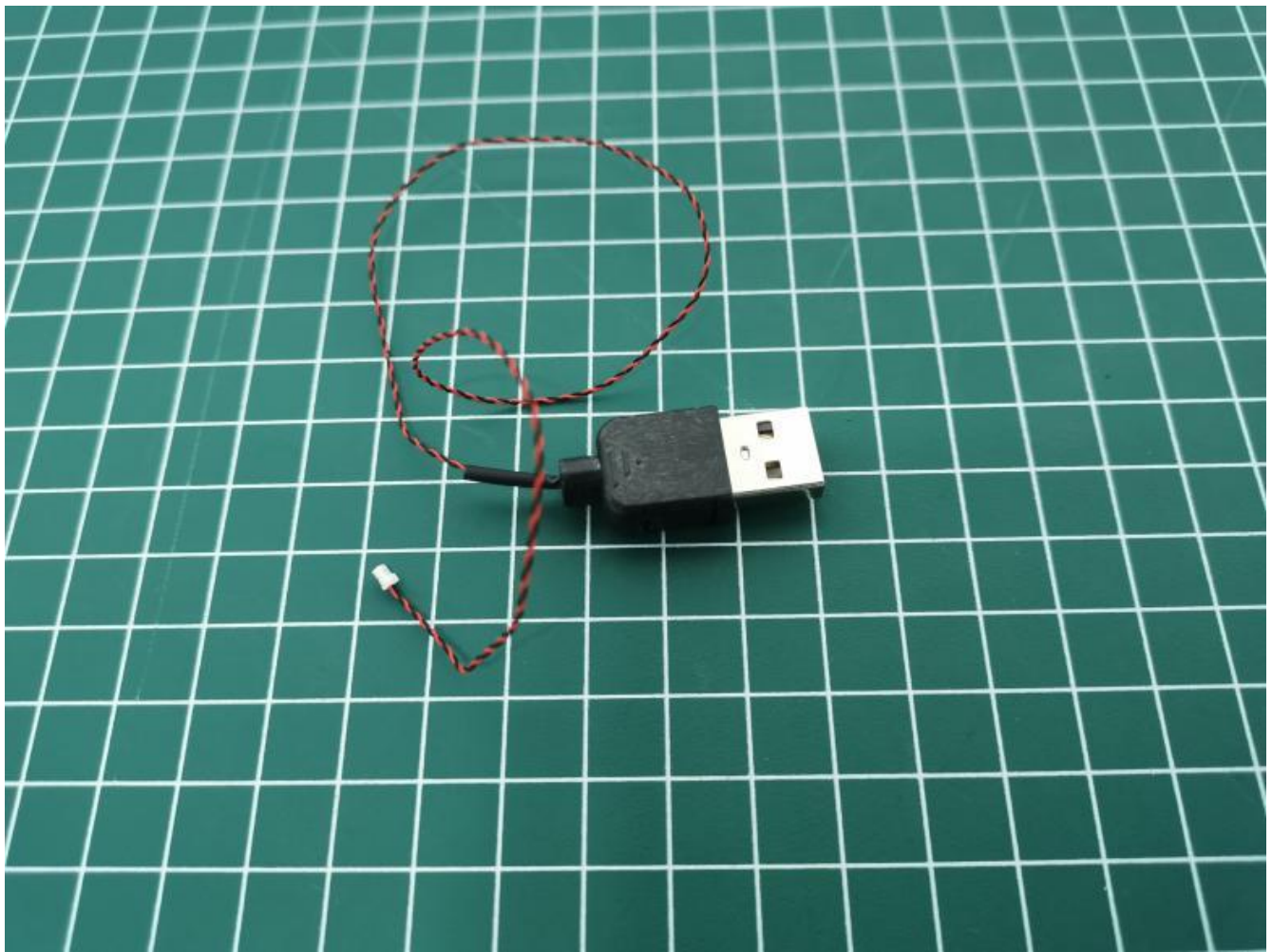

# USB connectors to connect devices

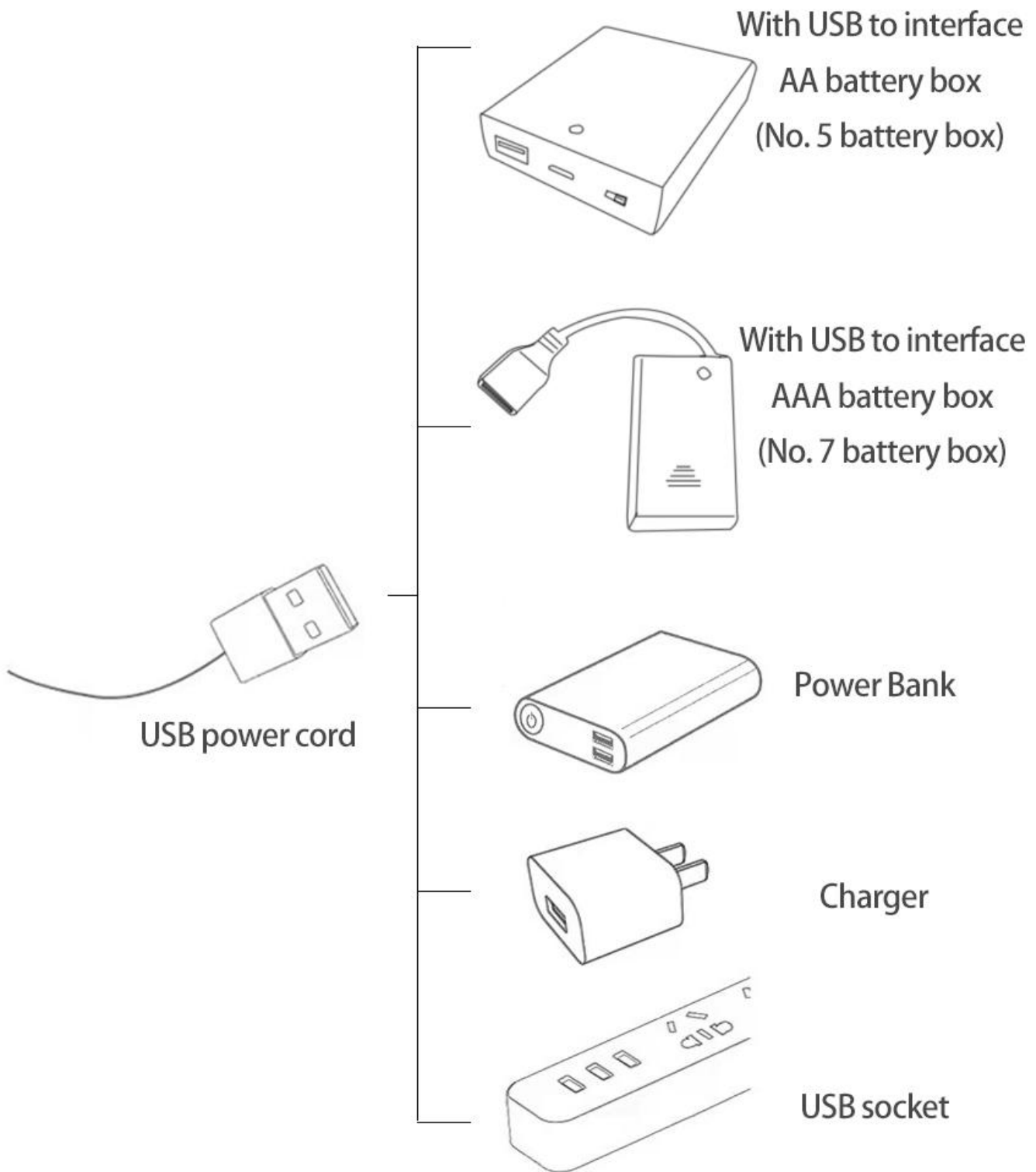

**Note:**

Please be careful when installing. The lamp wire is relatively slender and cannot be pressed on the raised position of the building block. It should pass along the gap, otherwise the lamp wire will be pinched.

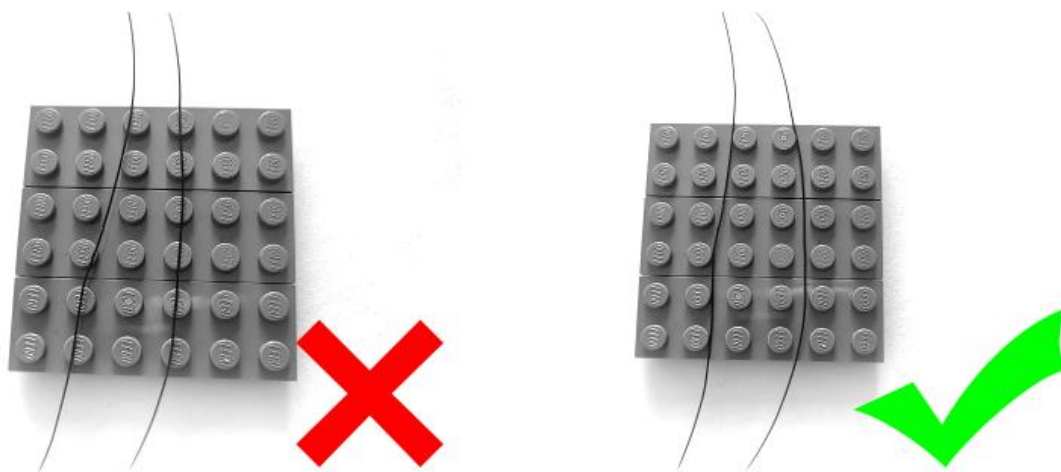

**start installation:**



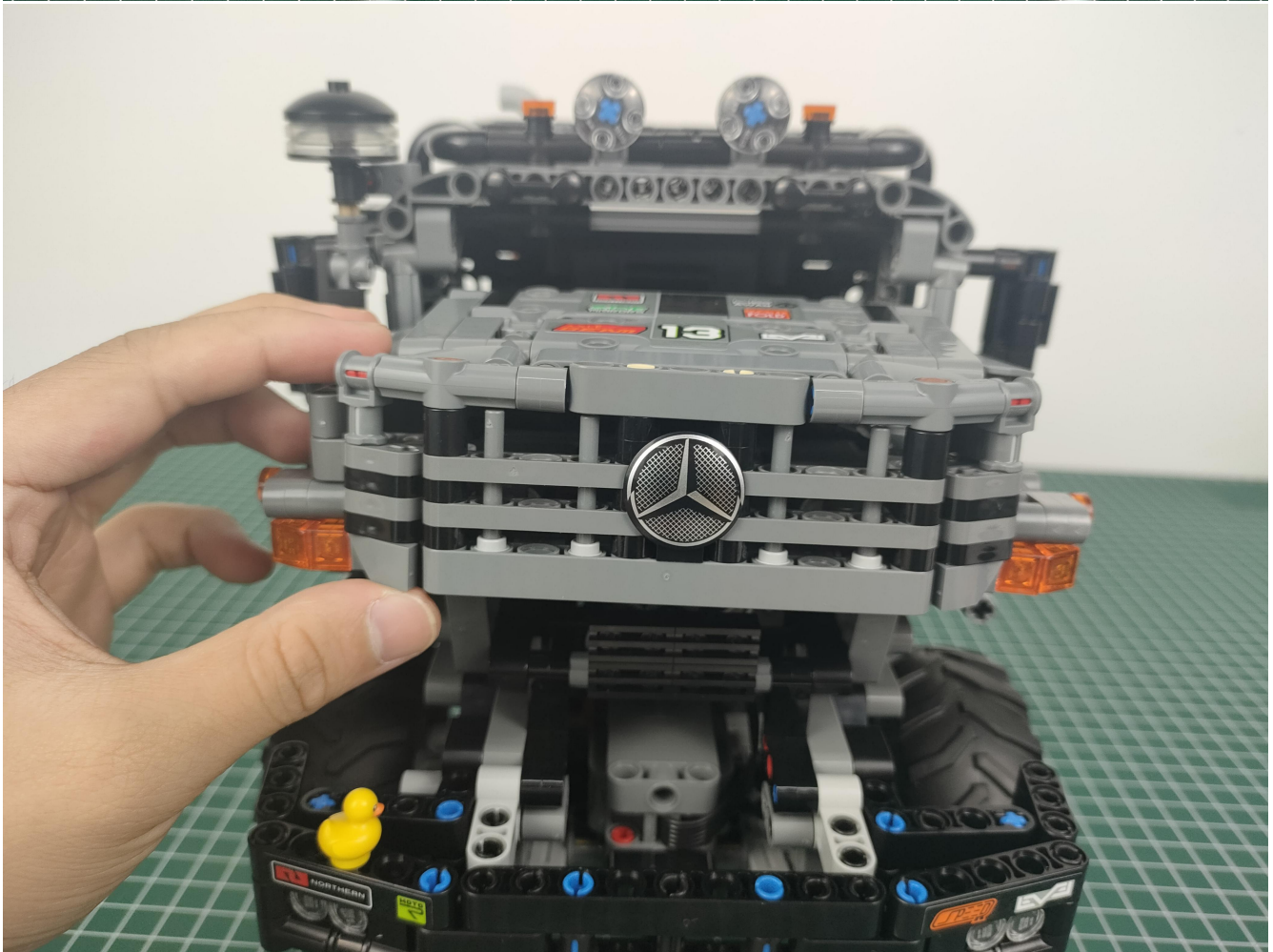

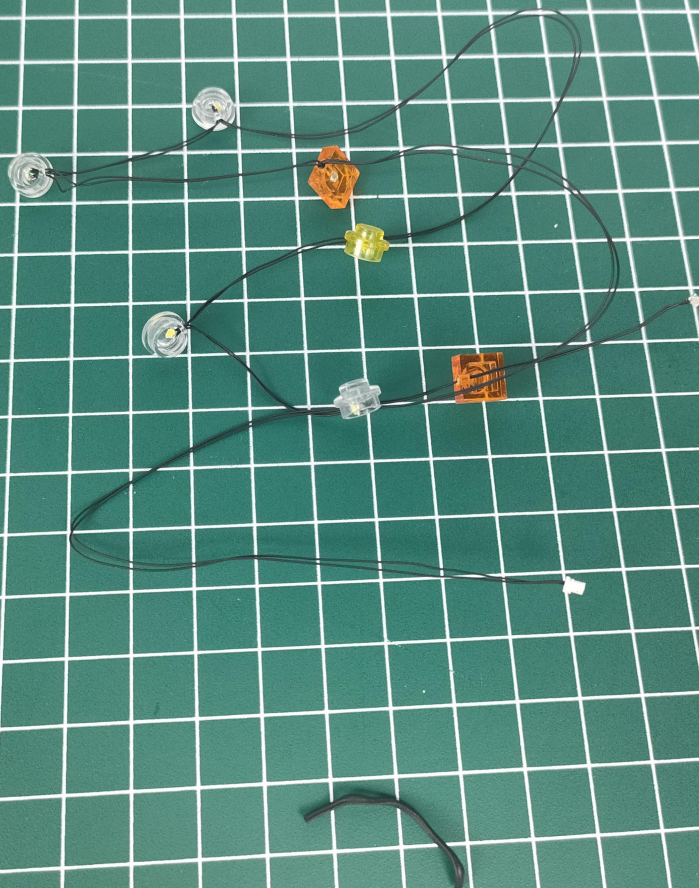
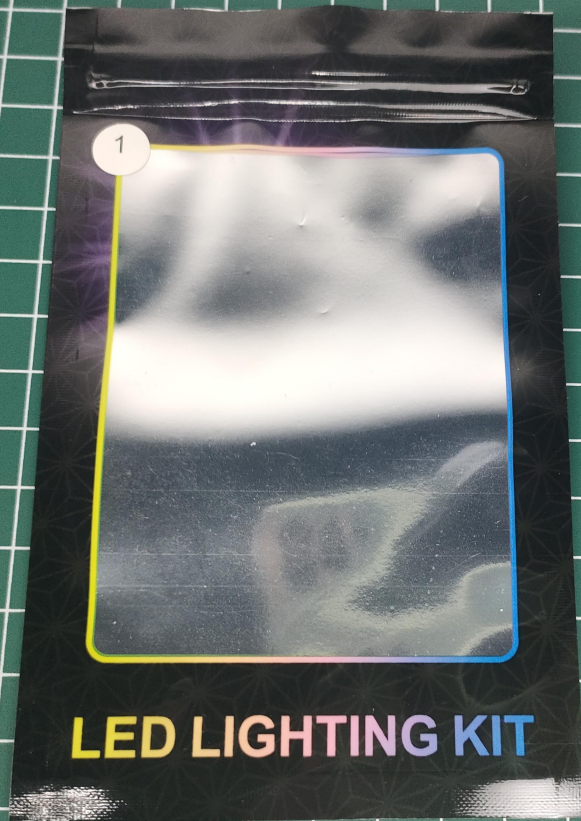

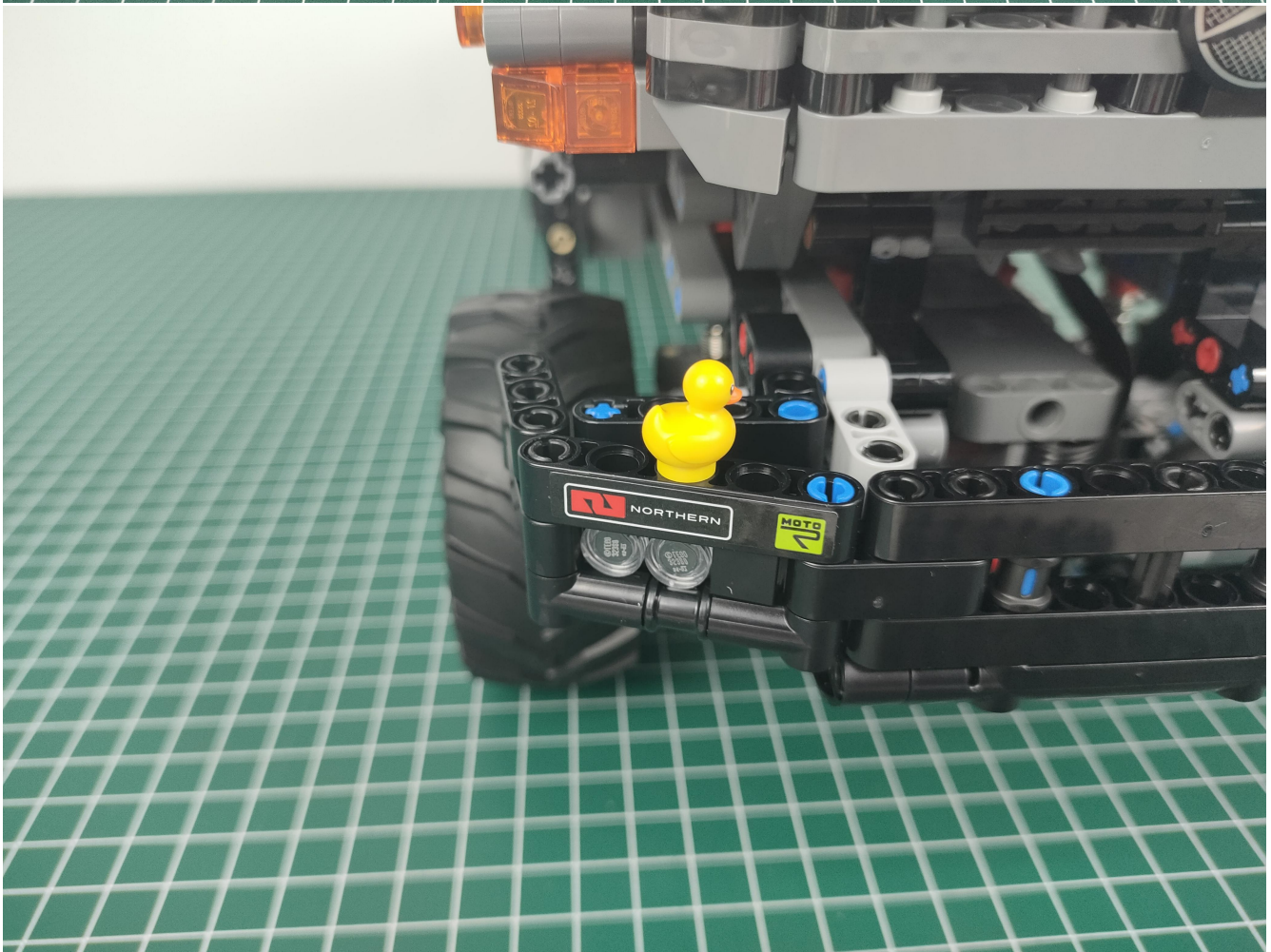
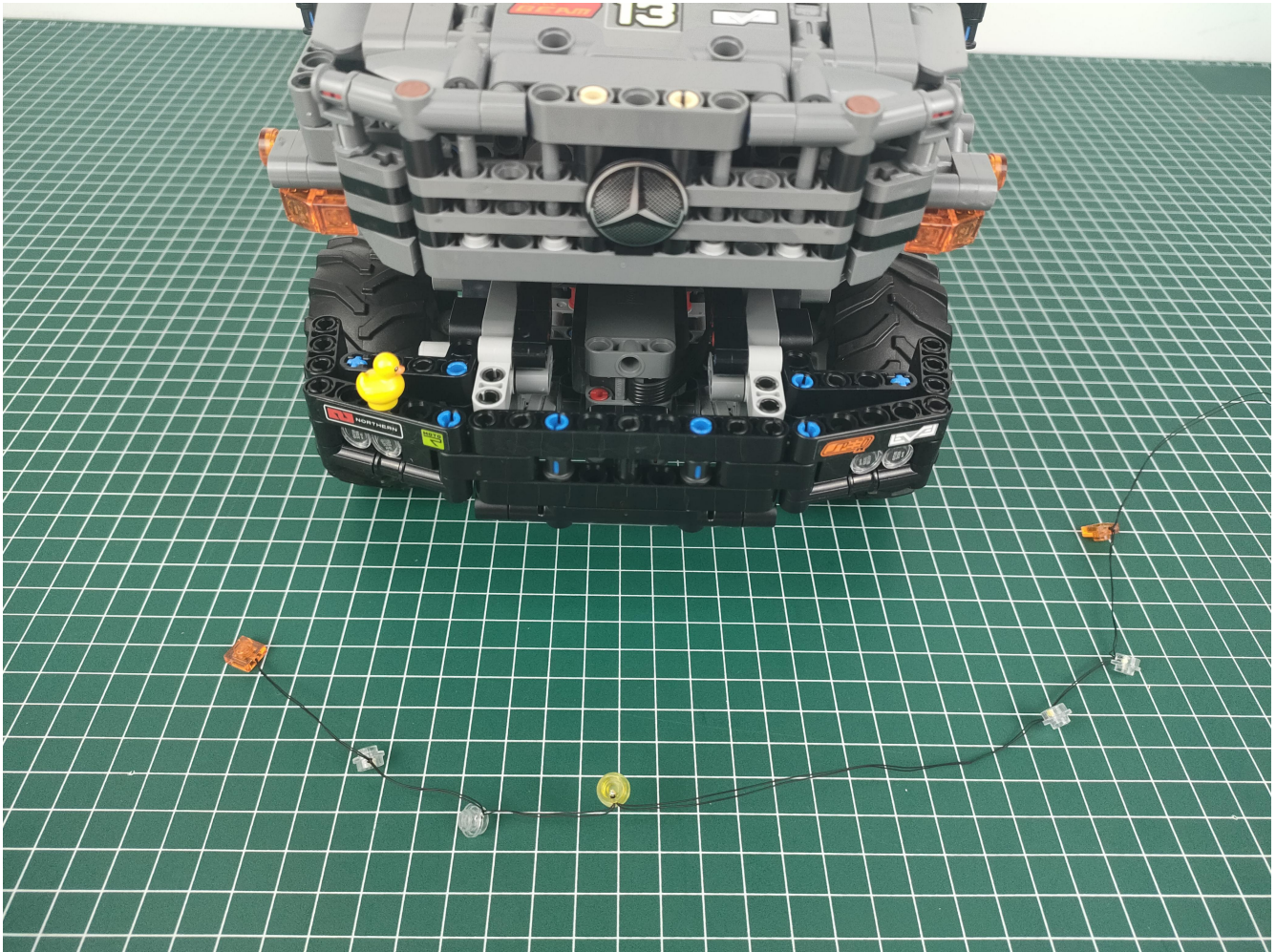

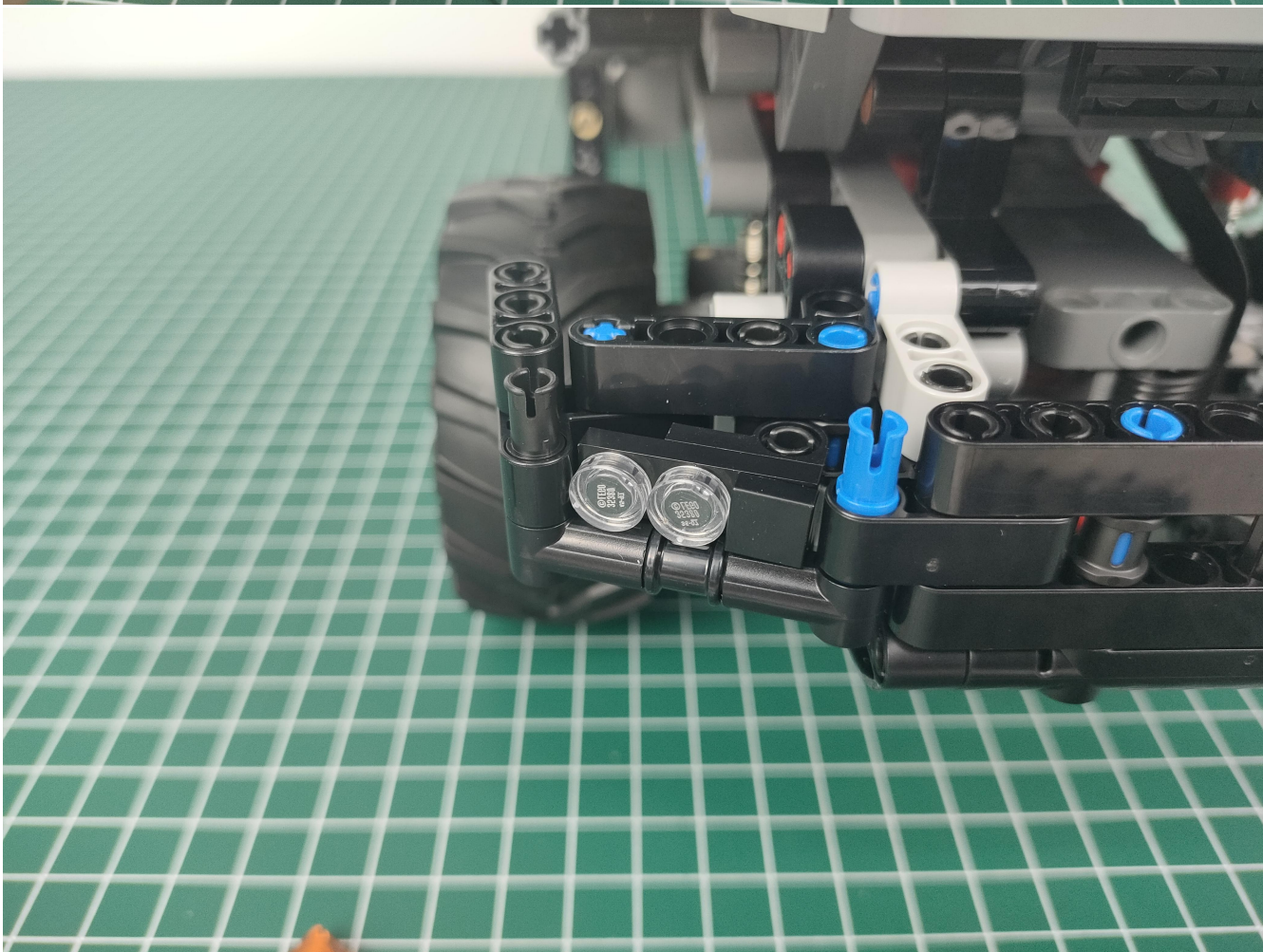
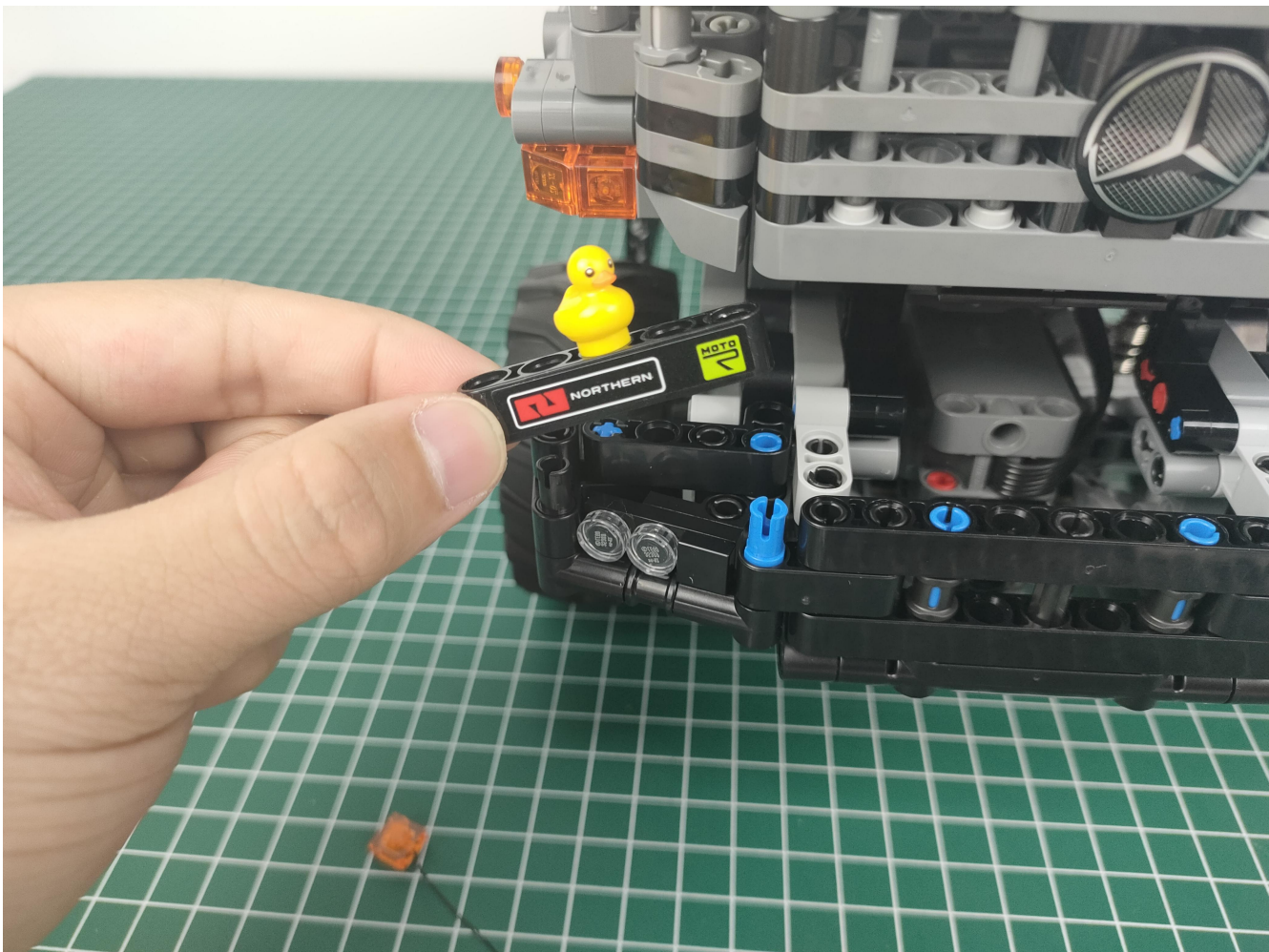



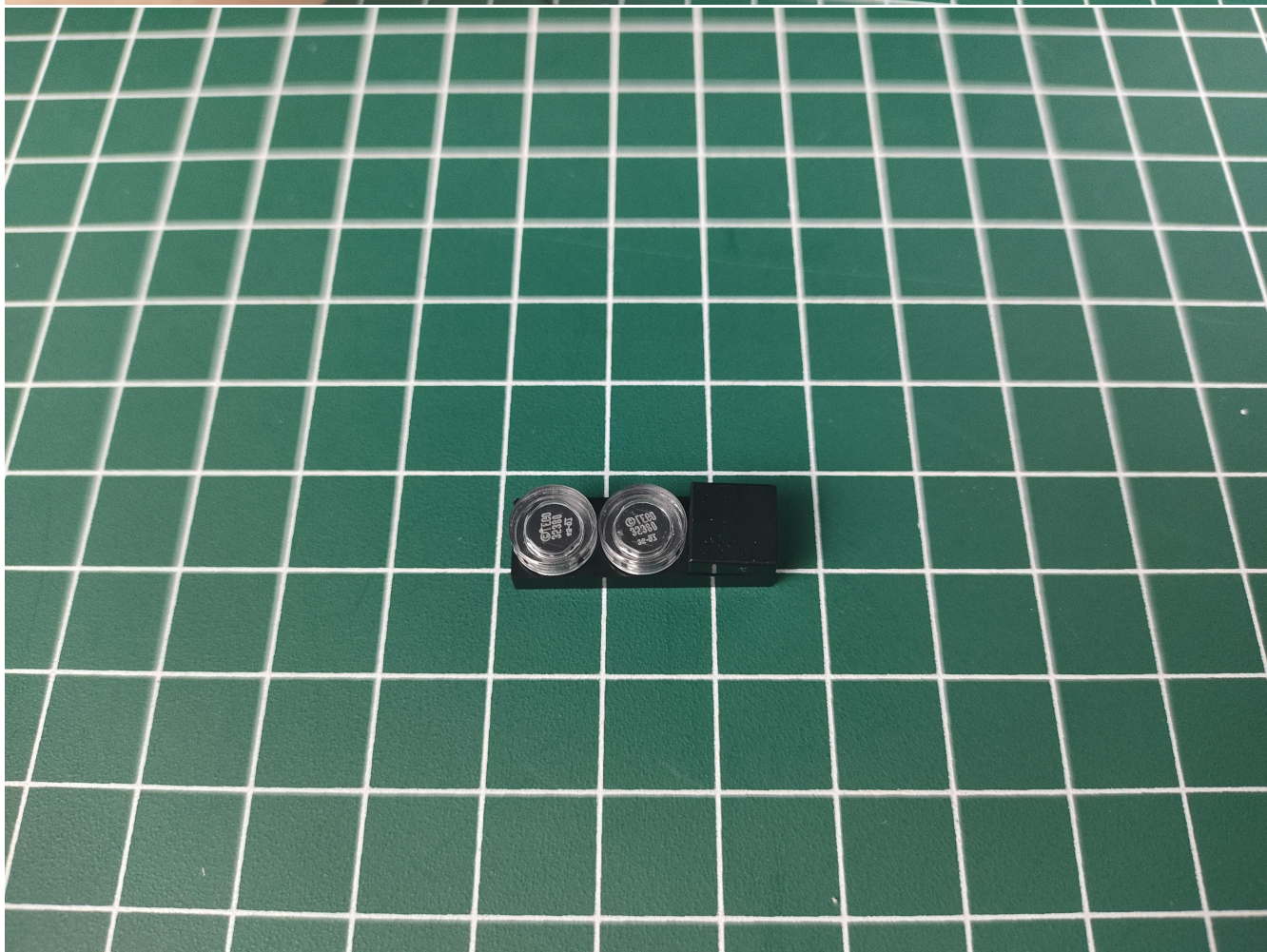
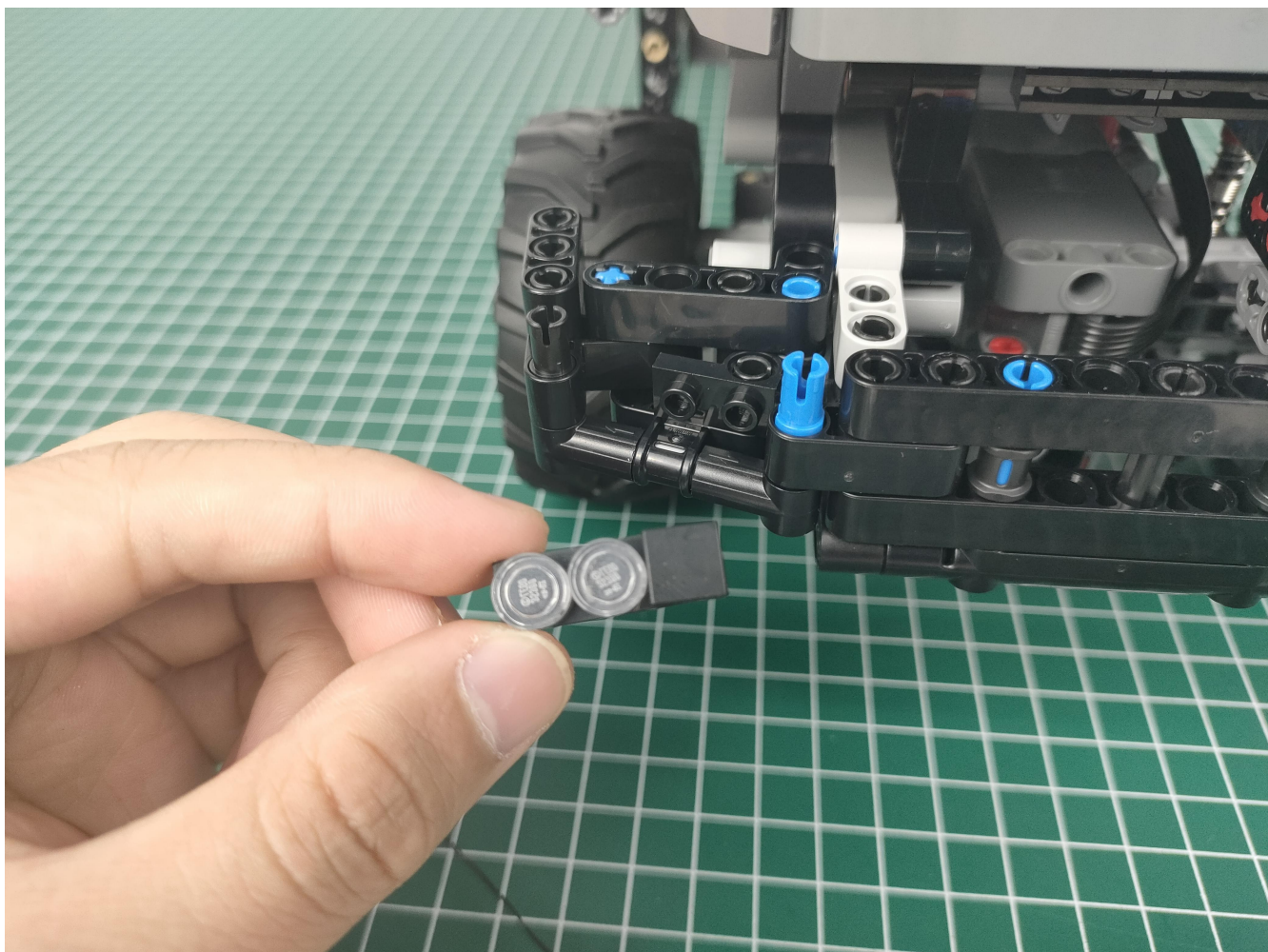

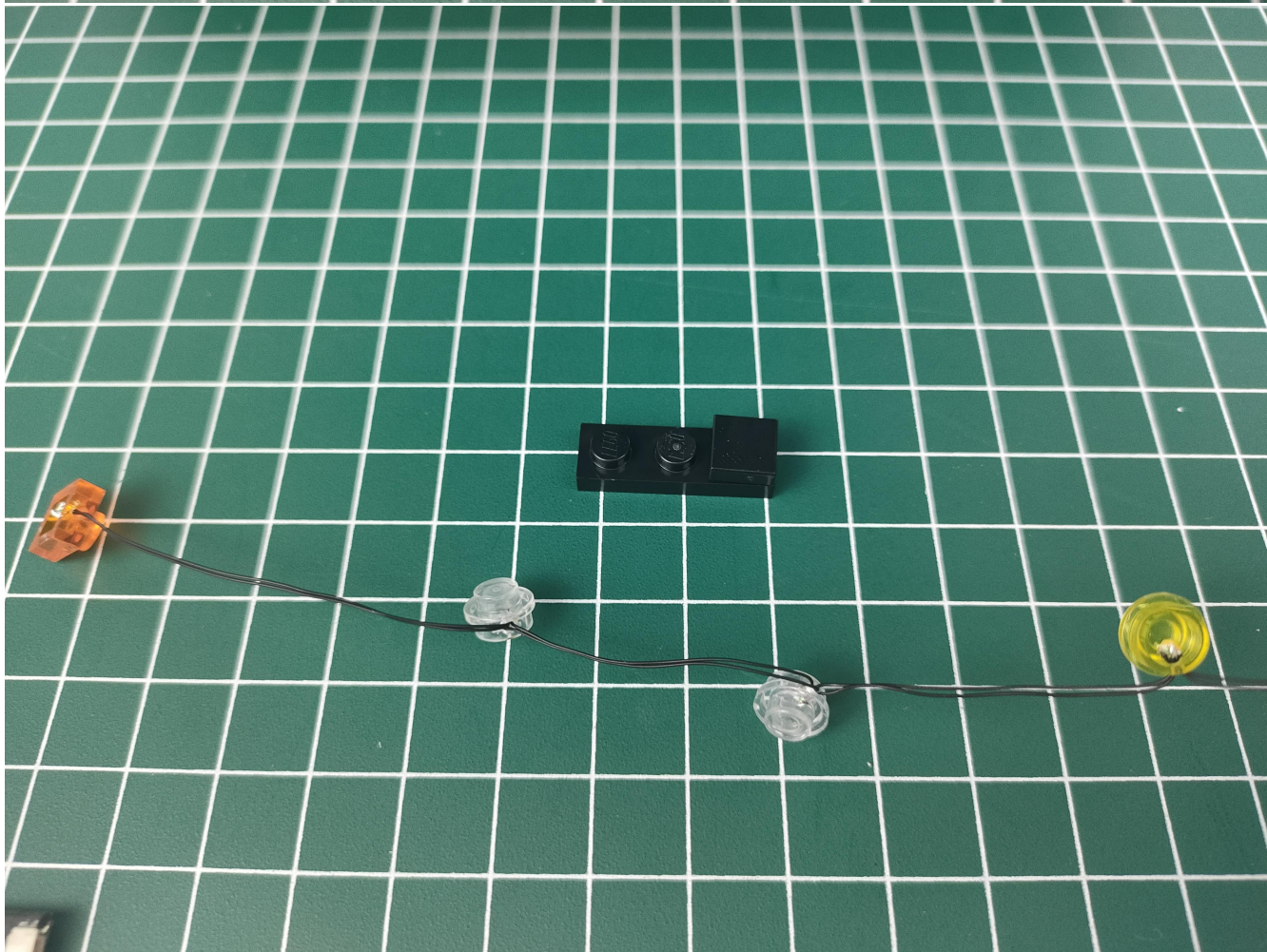
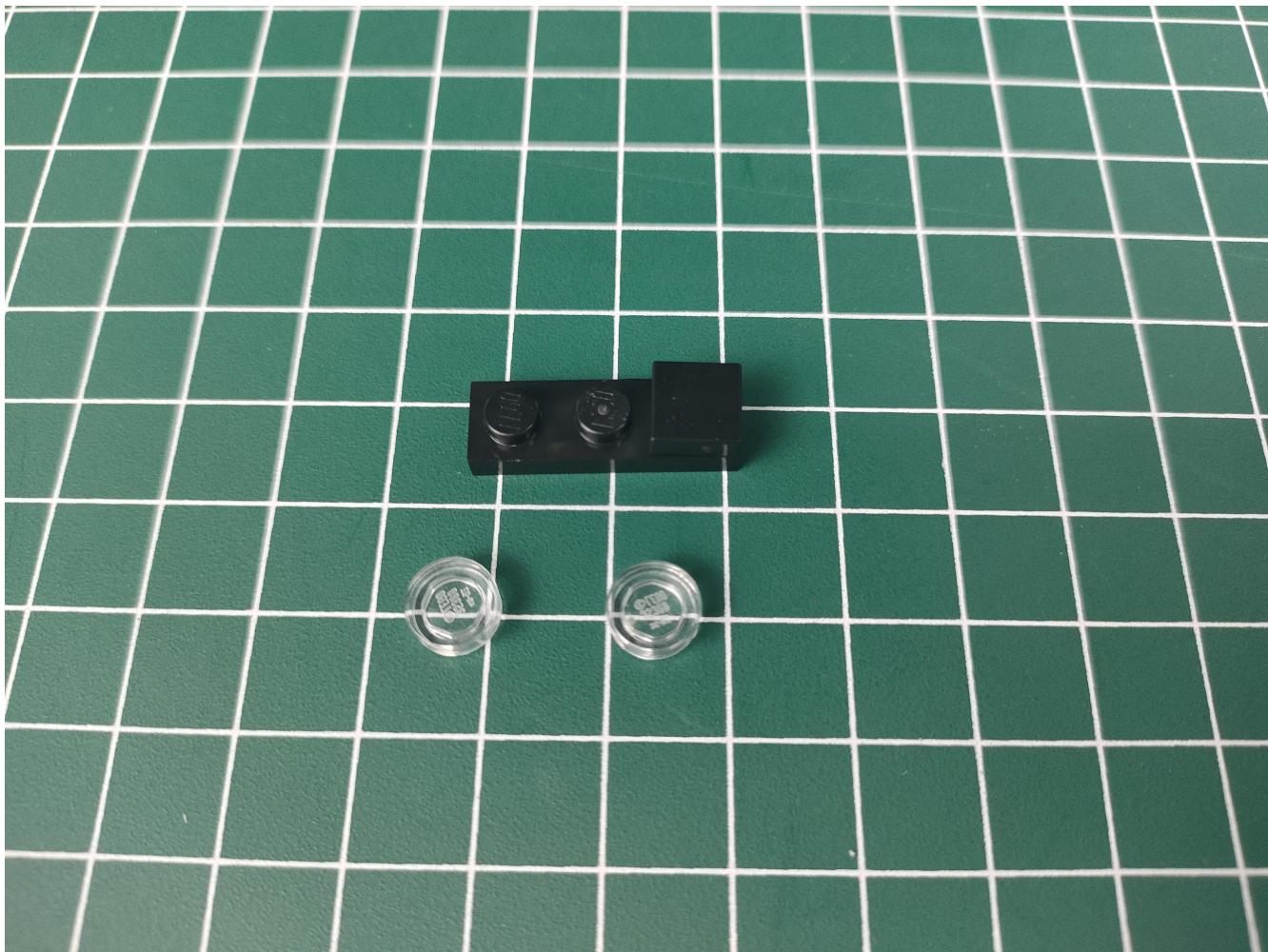

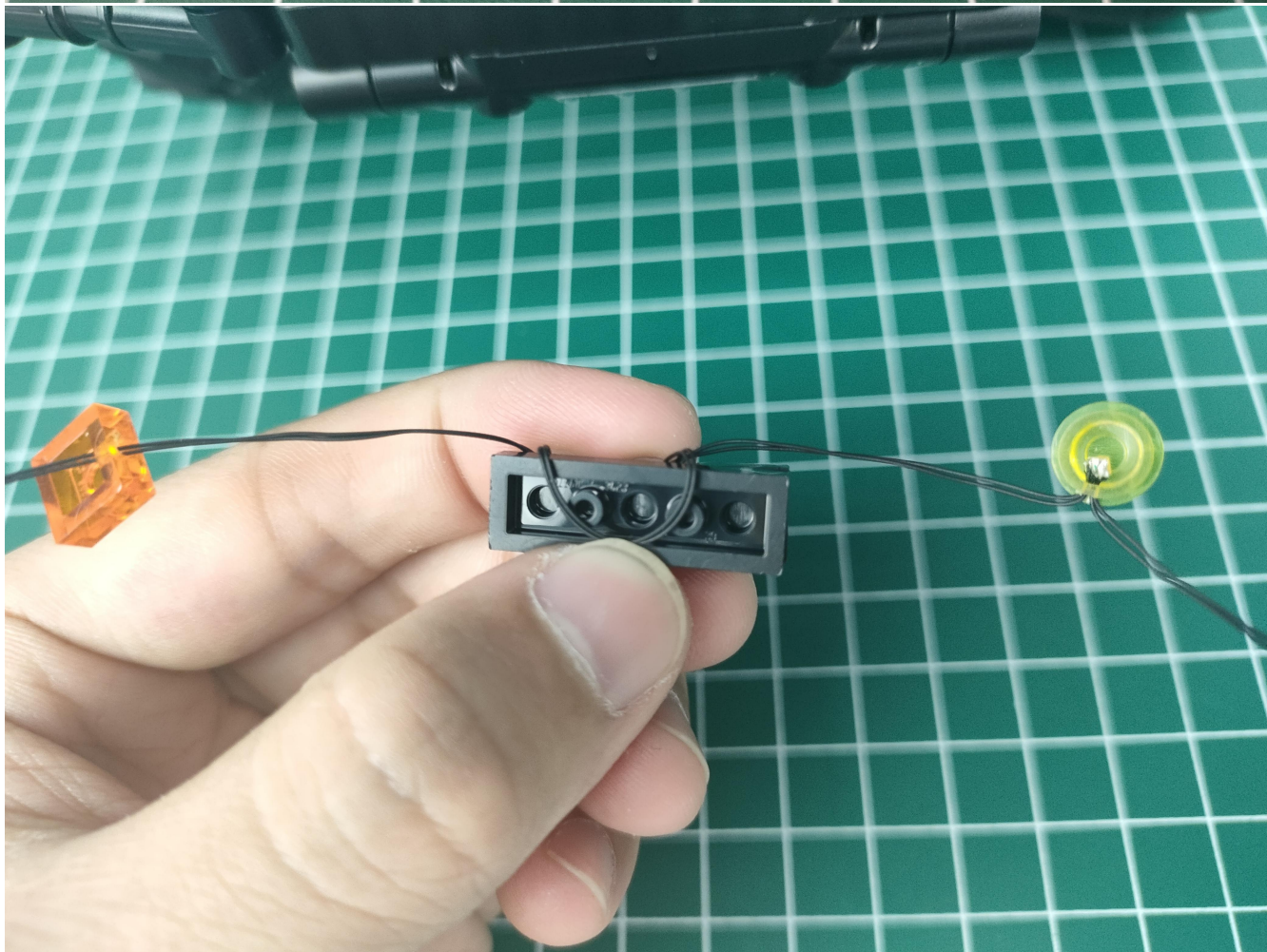

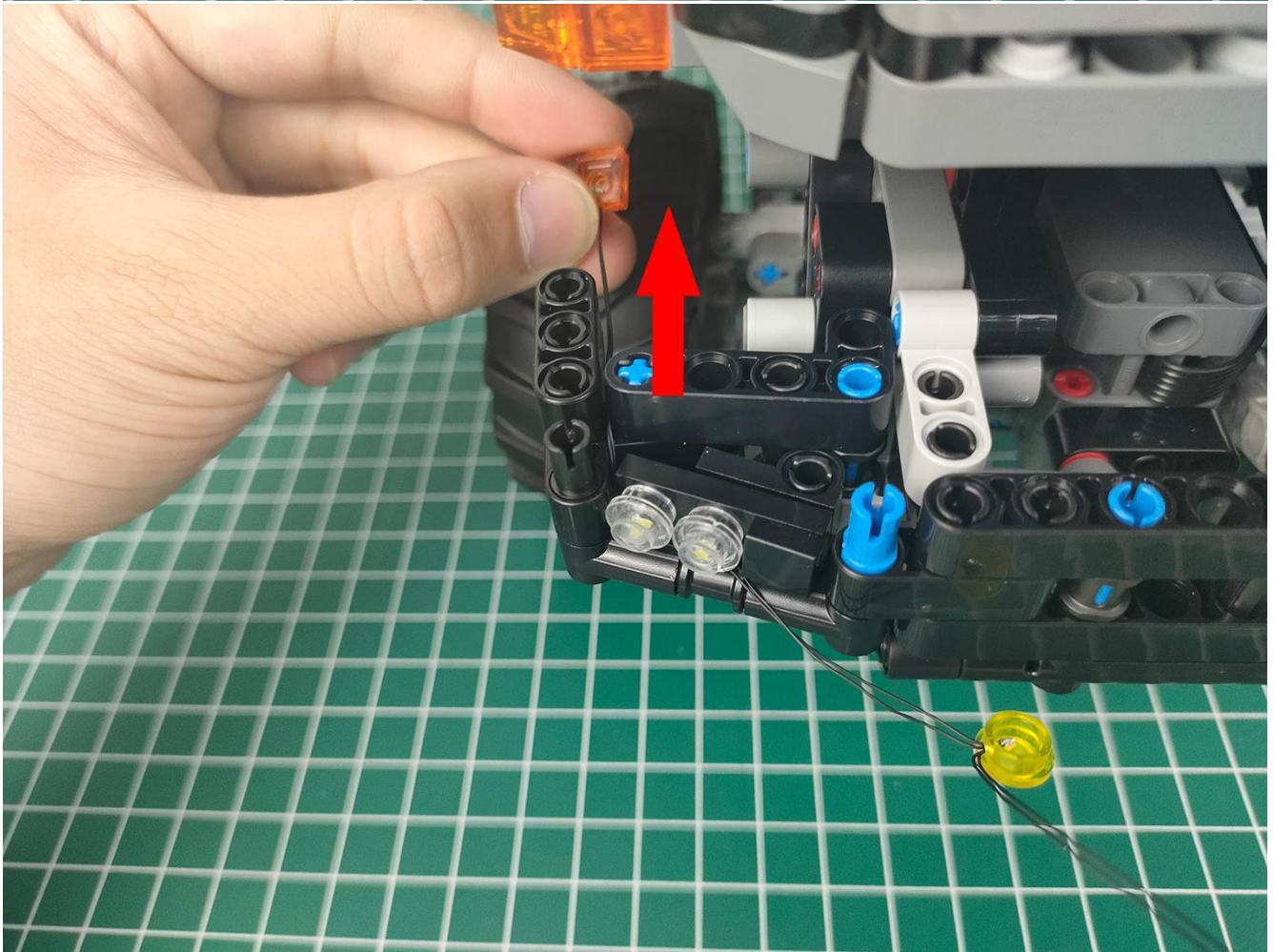
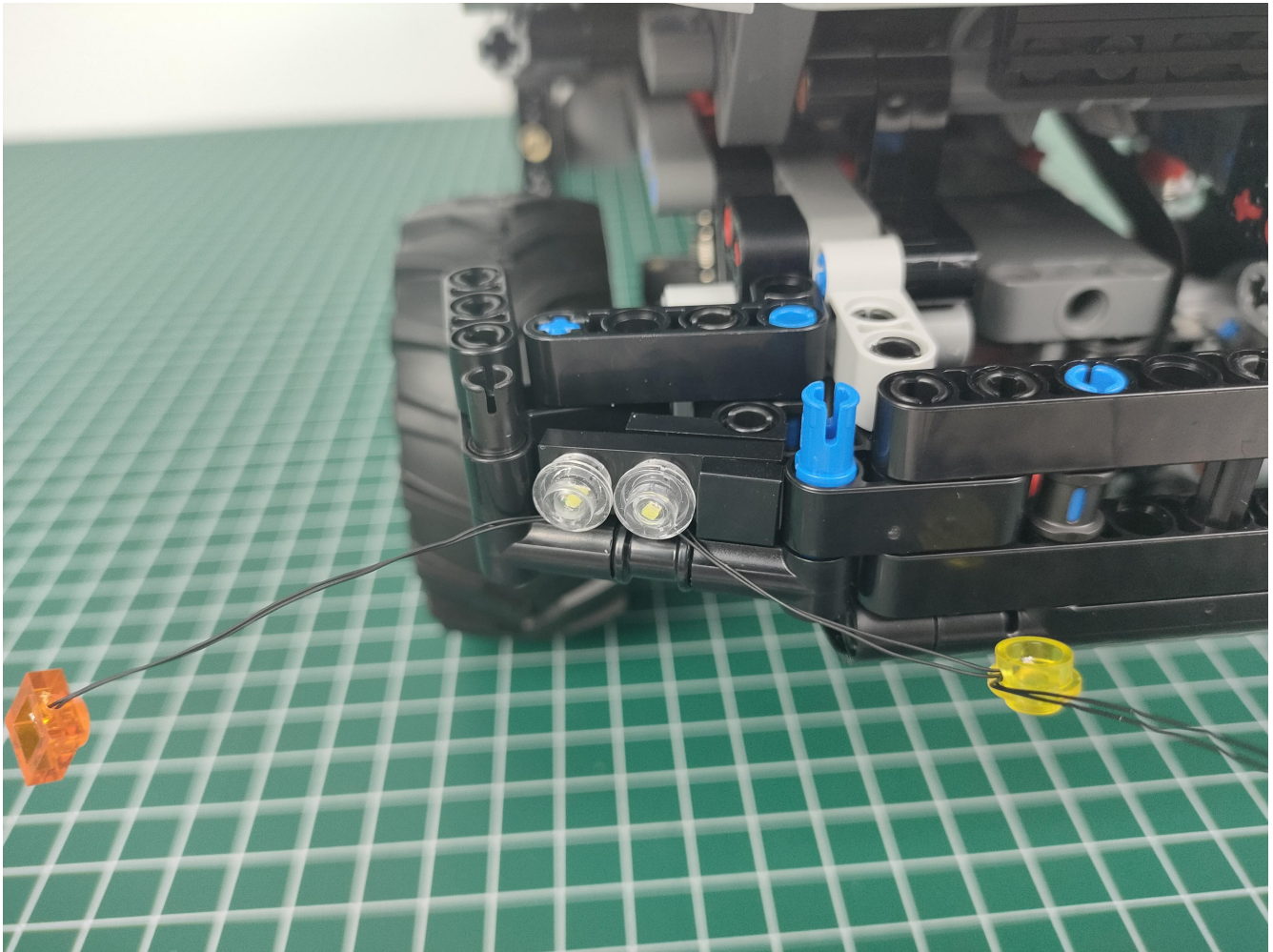

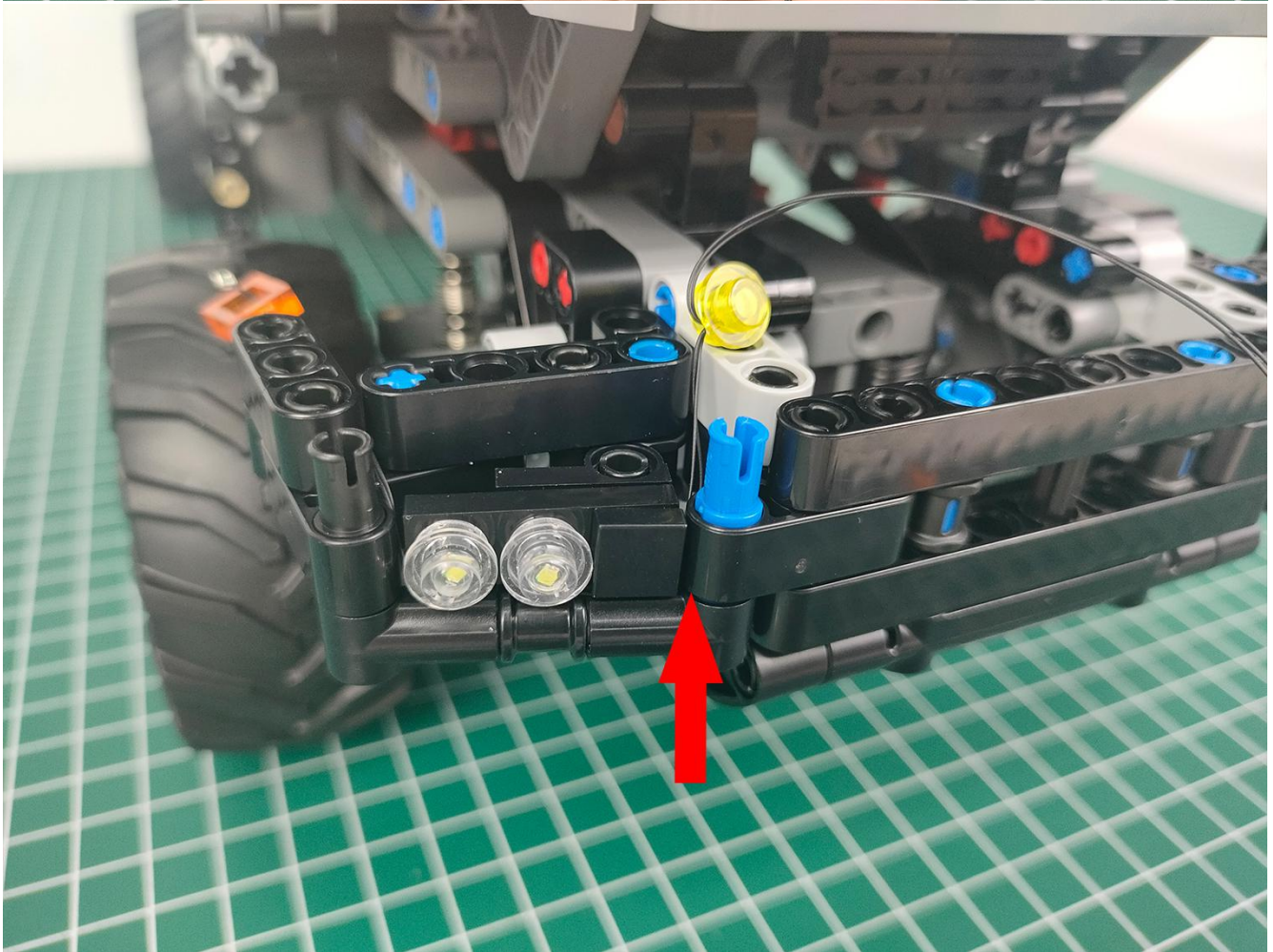
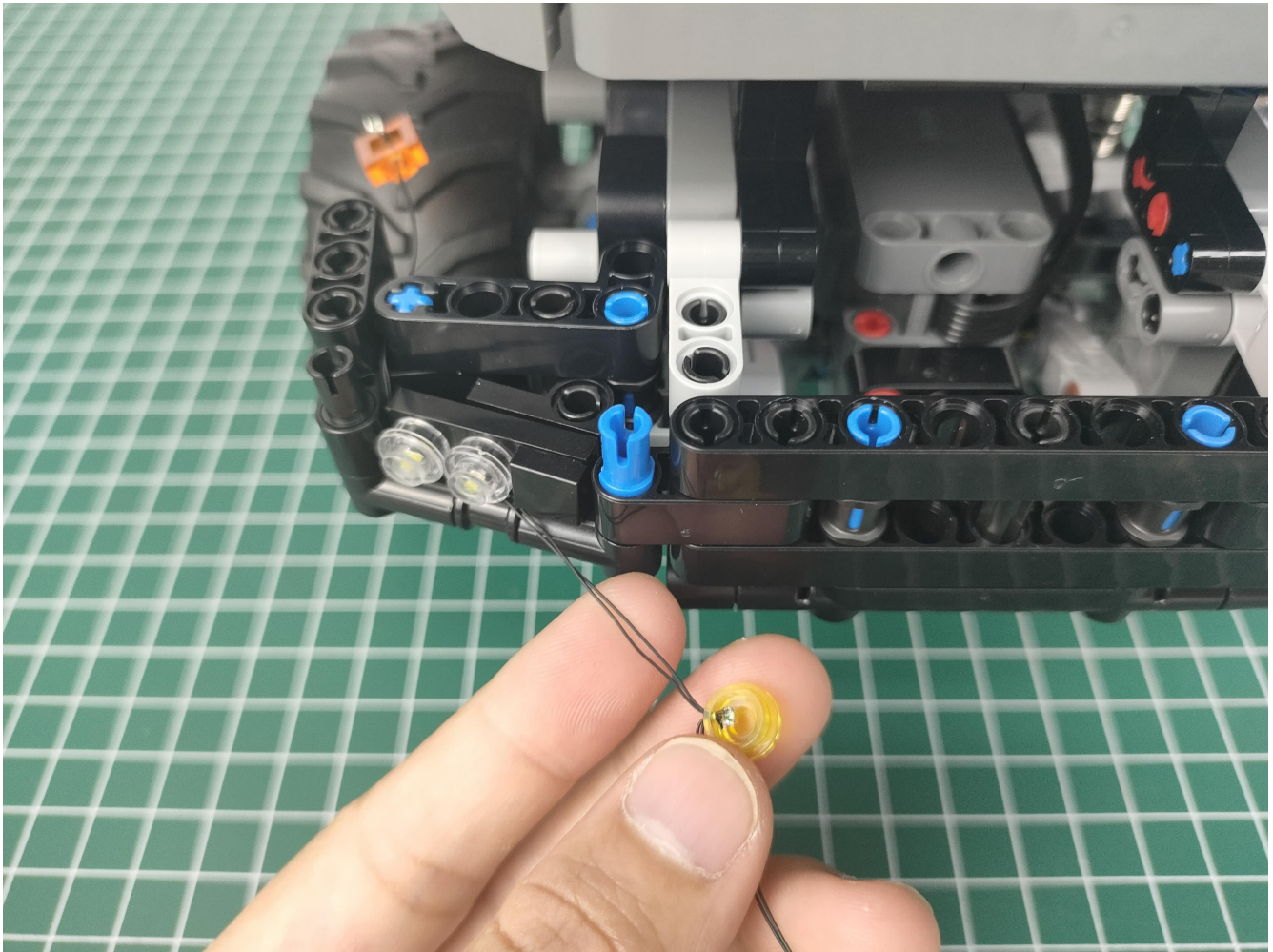

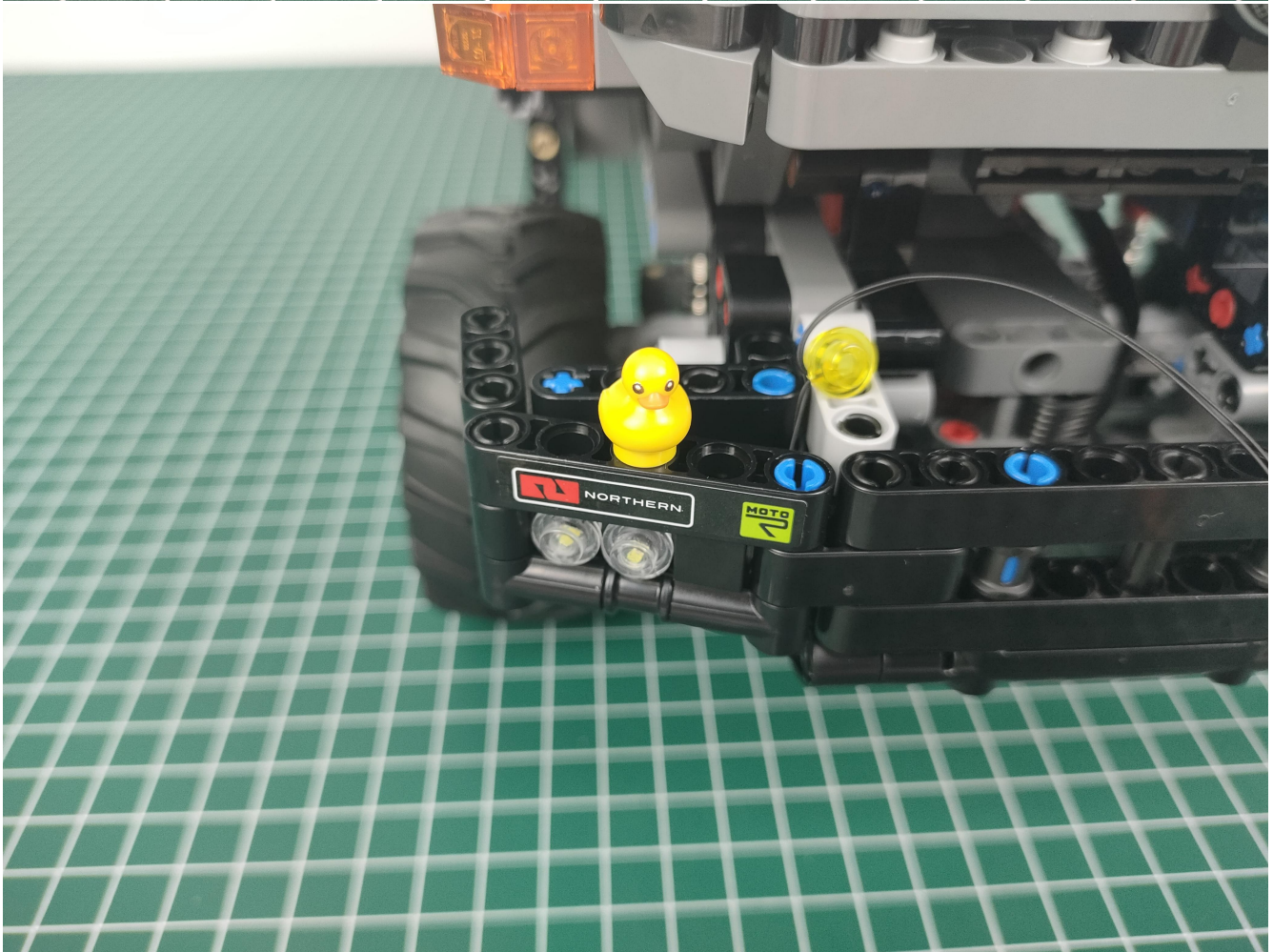

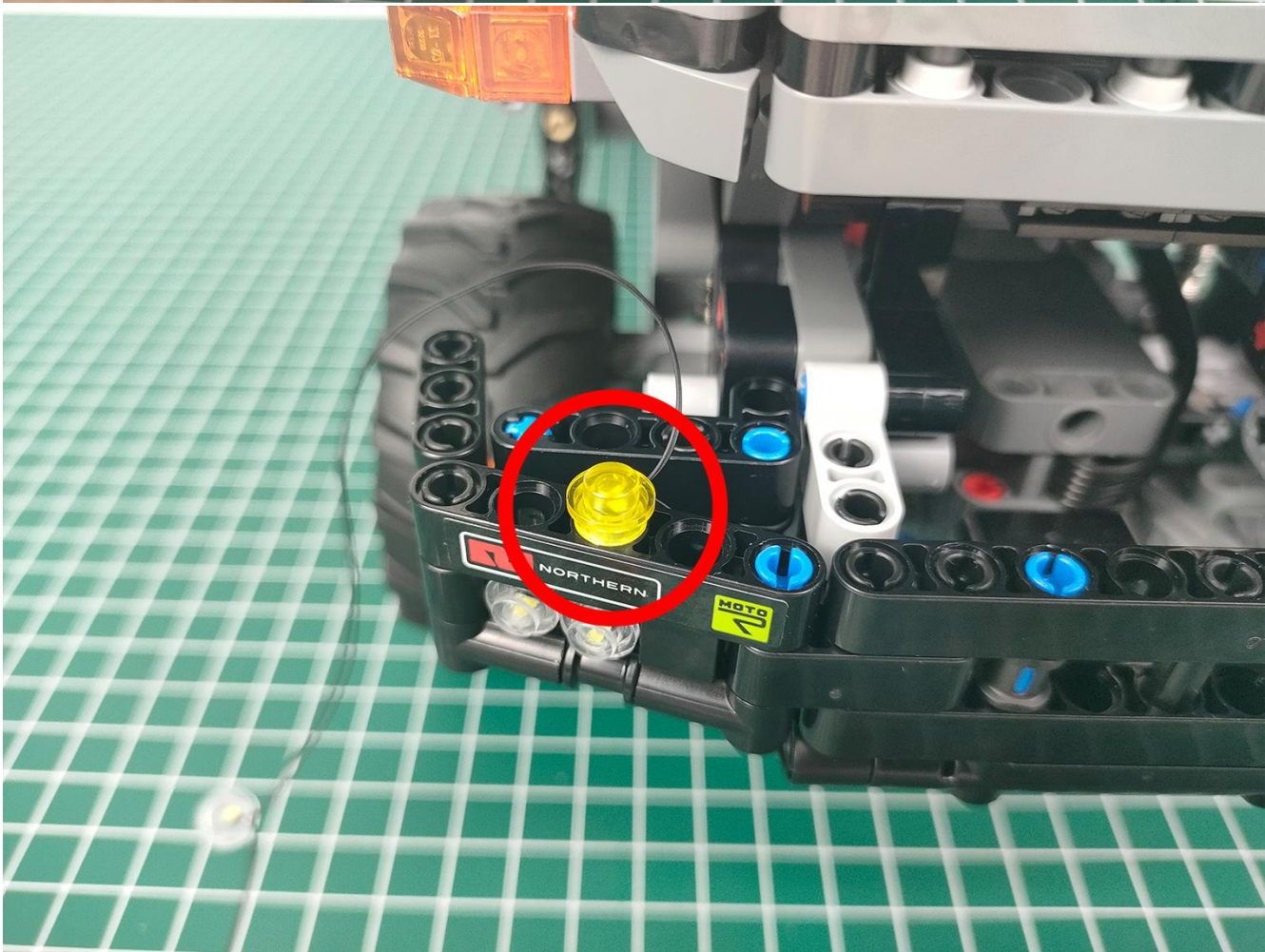
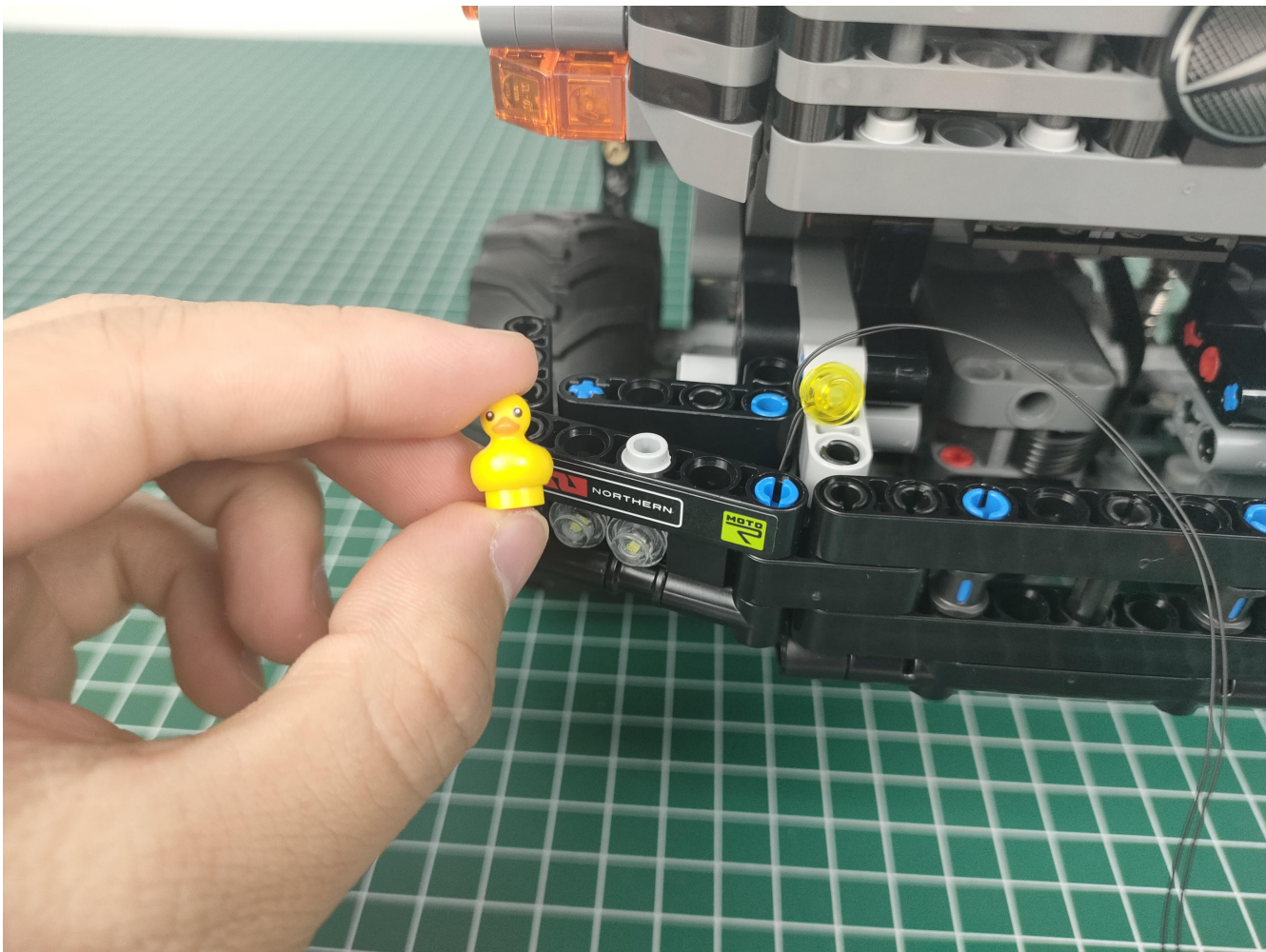

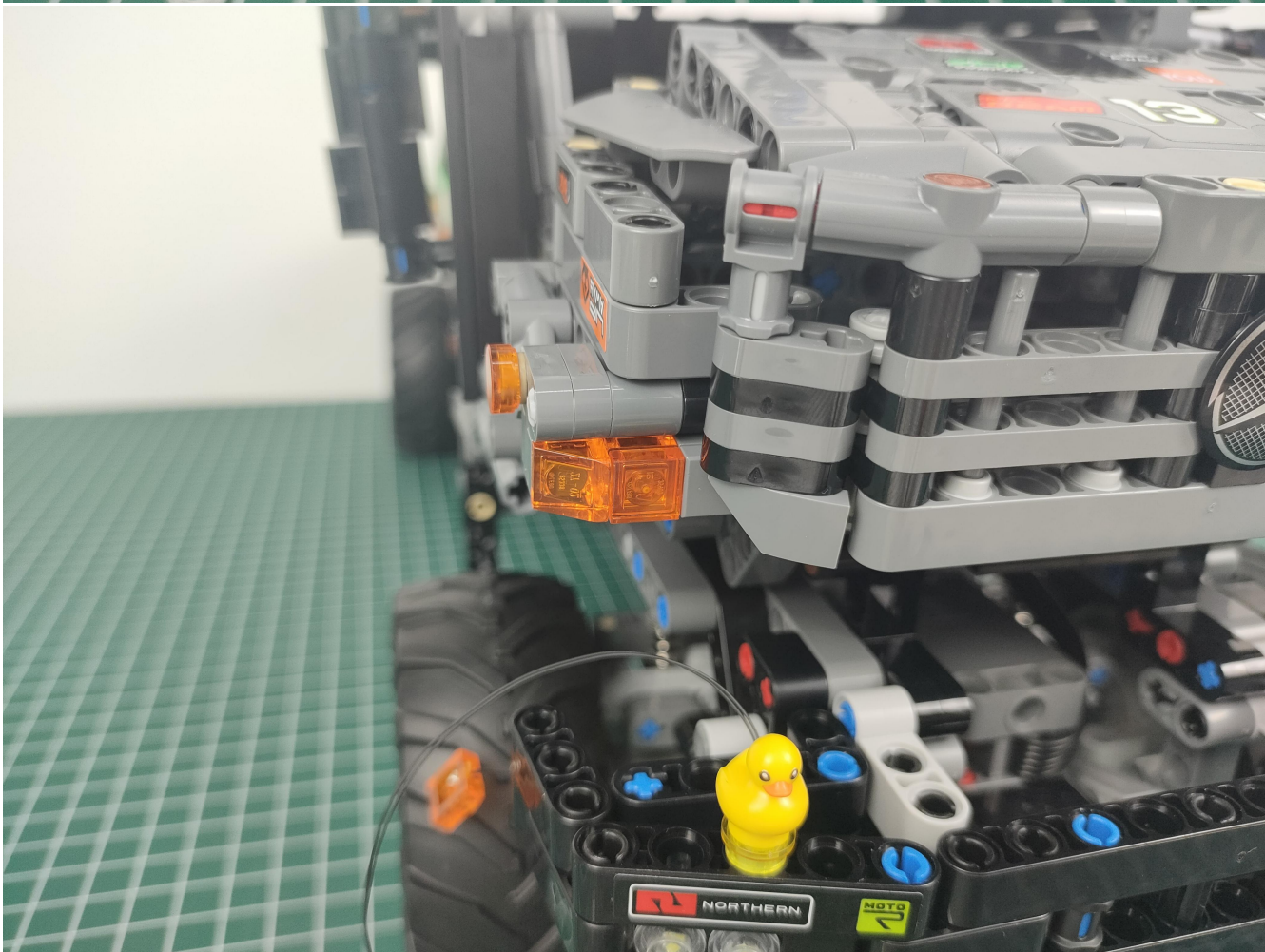
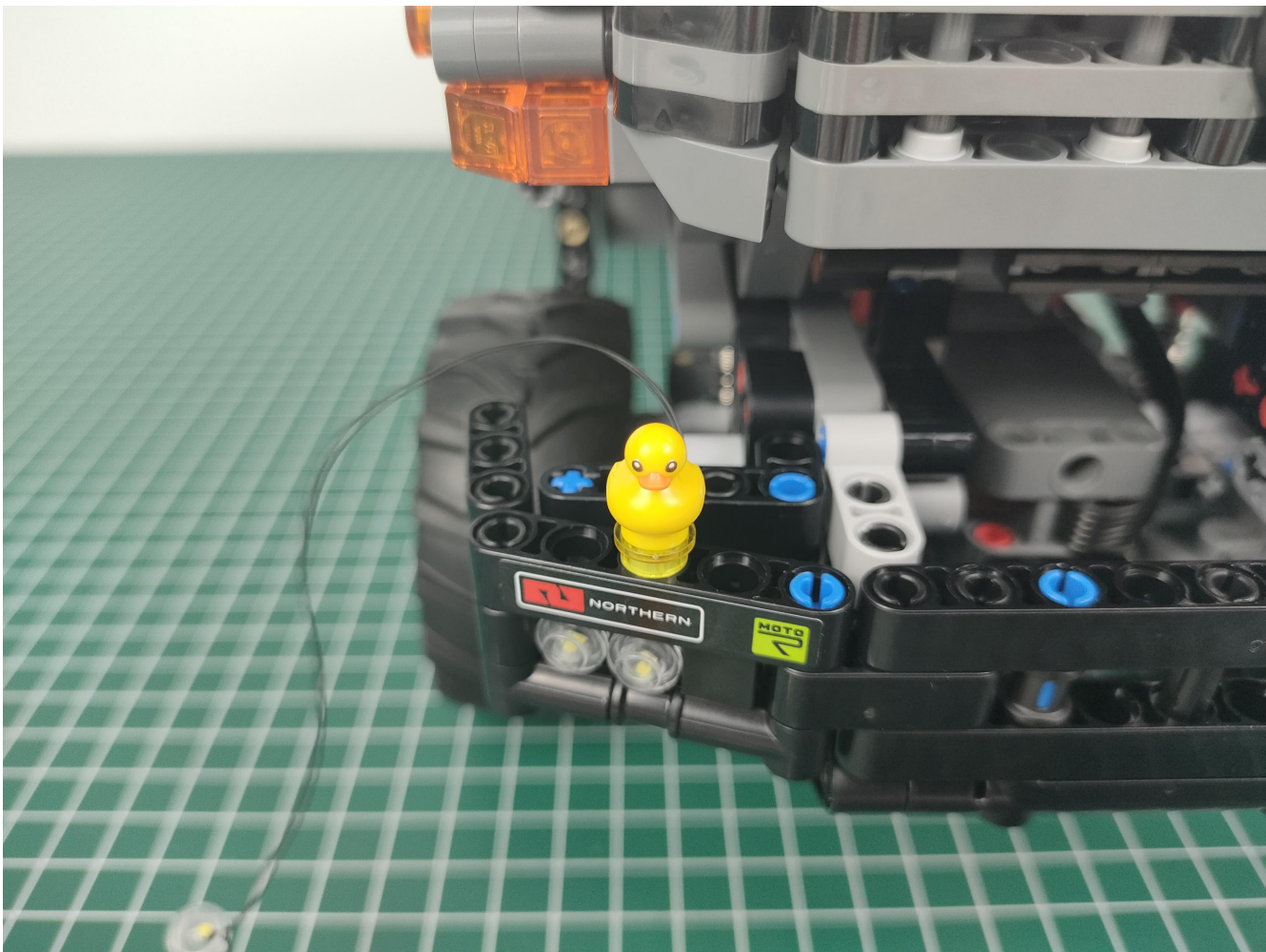



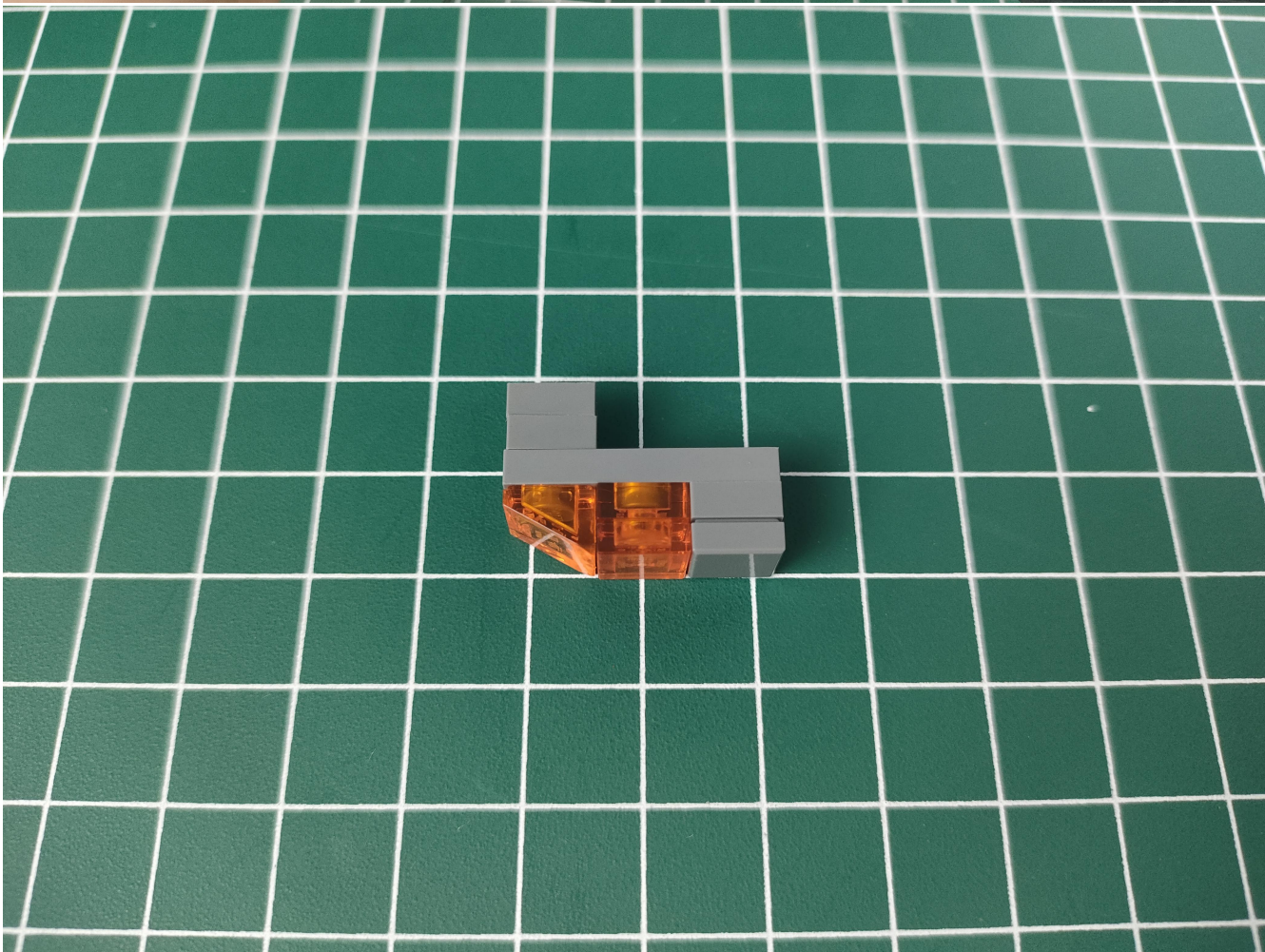
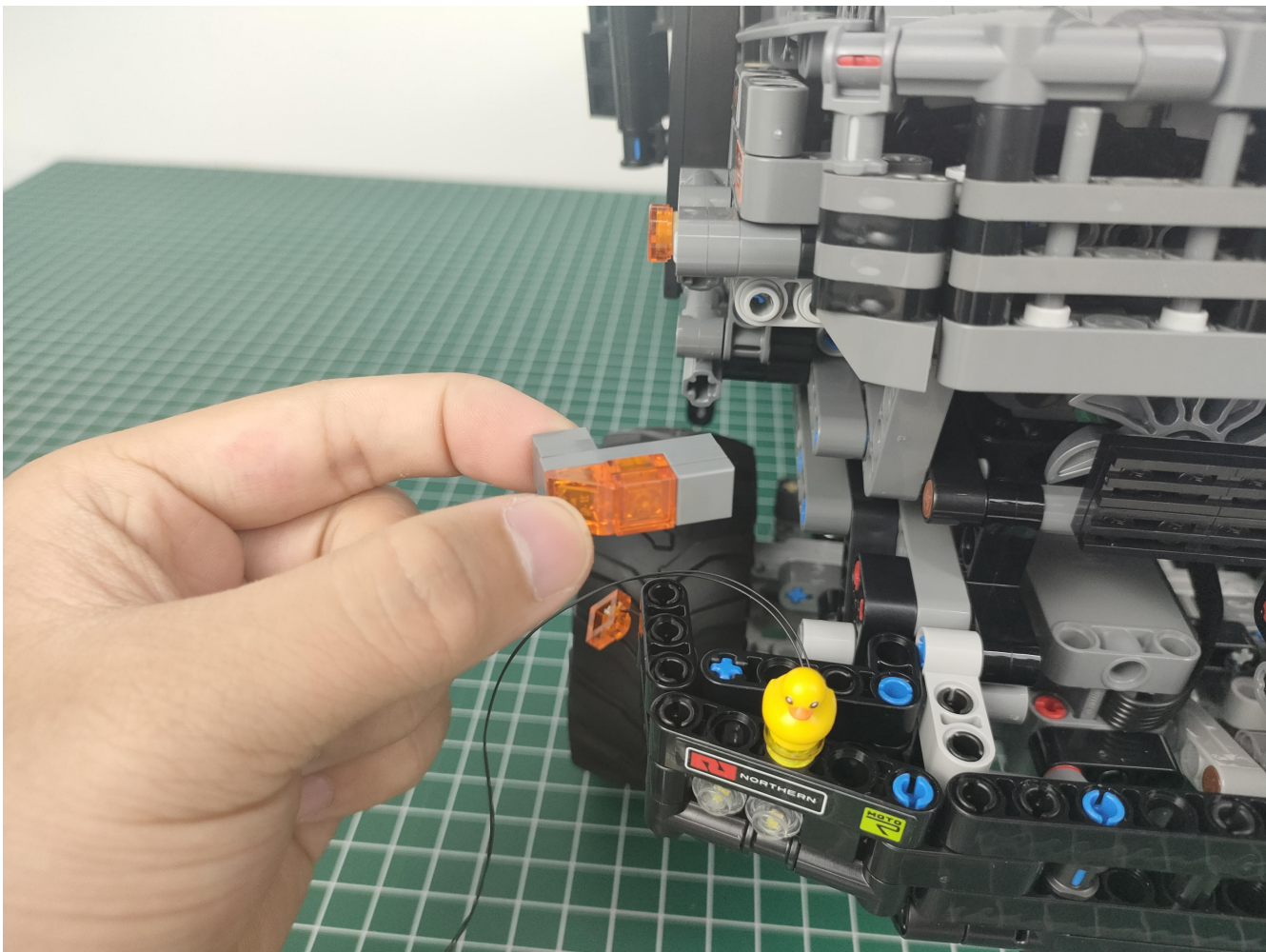

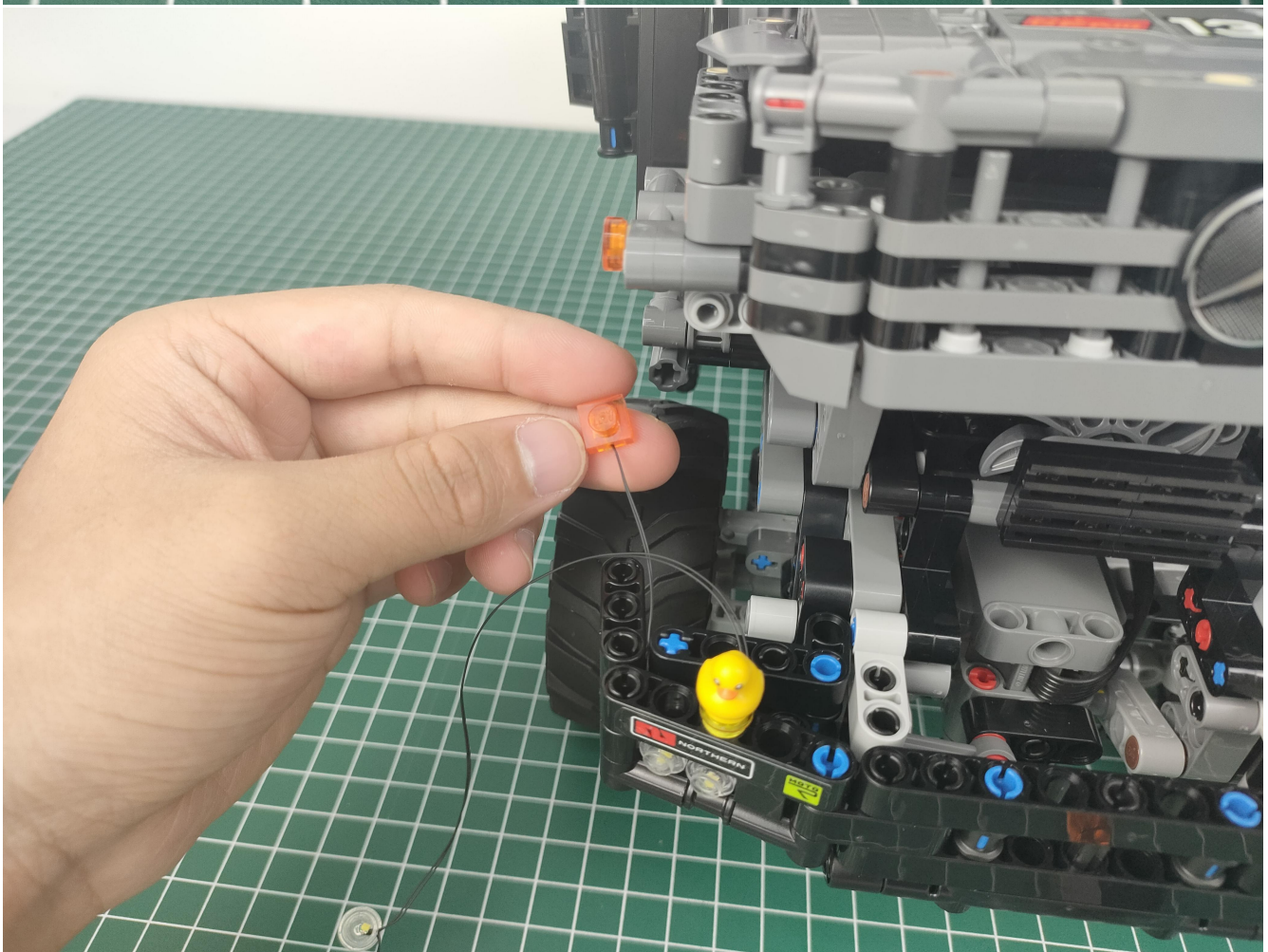
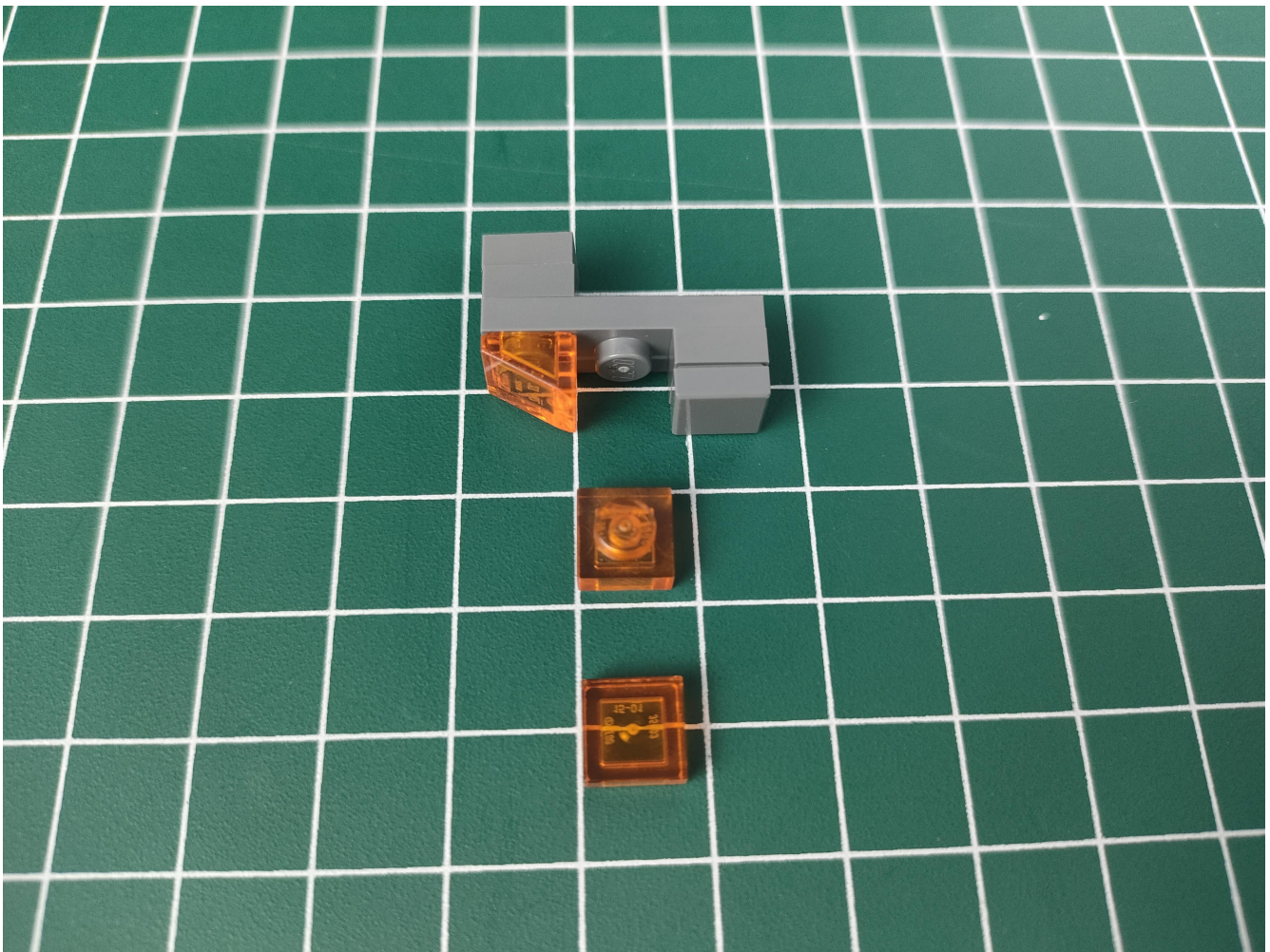

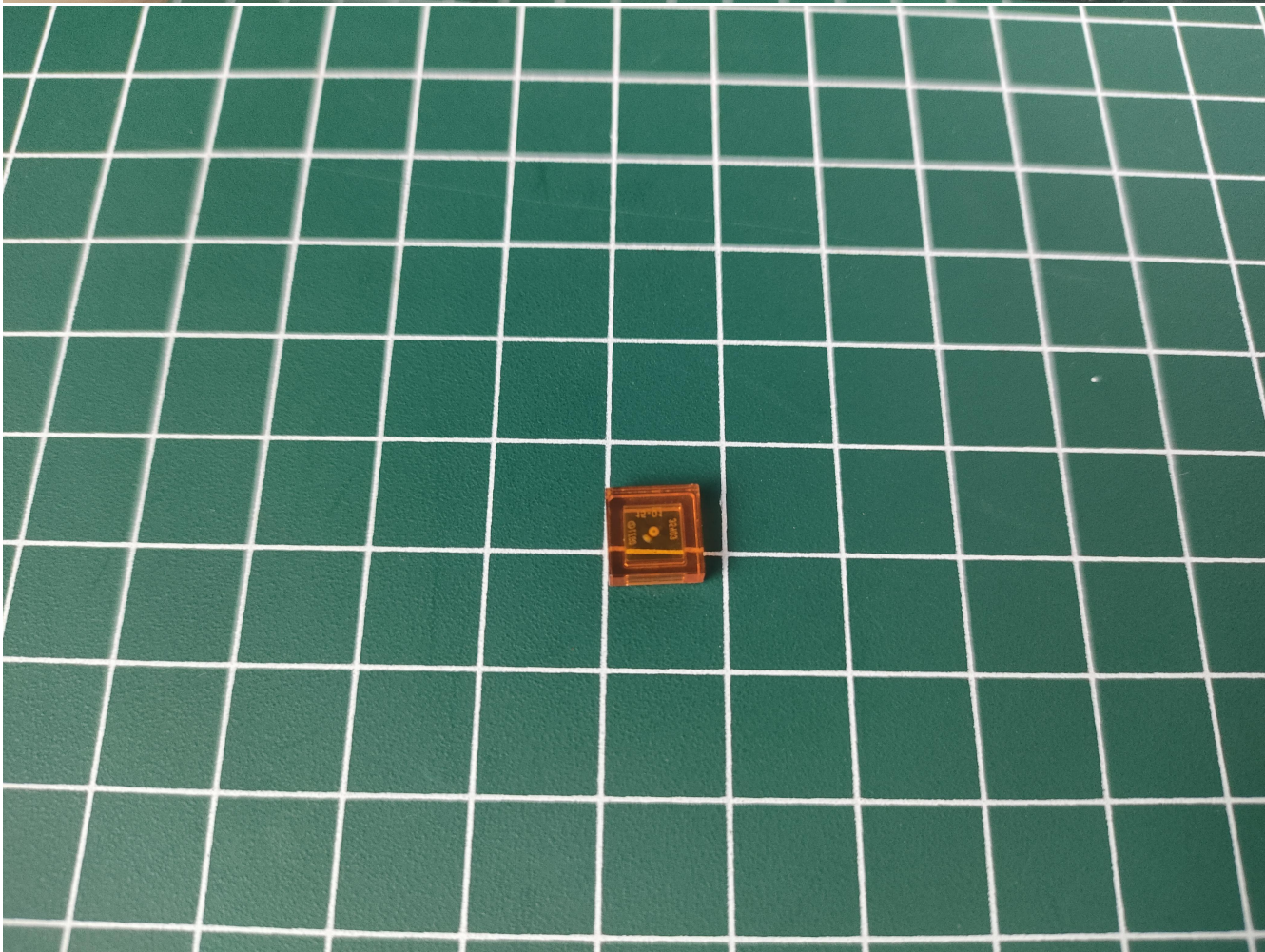
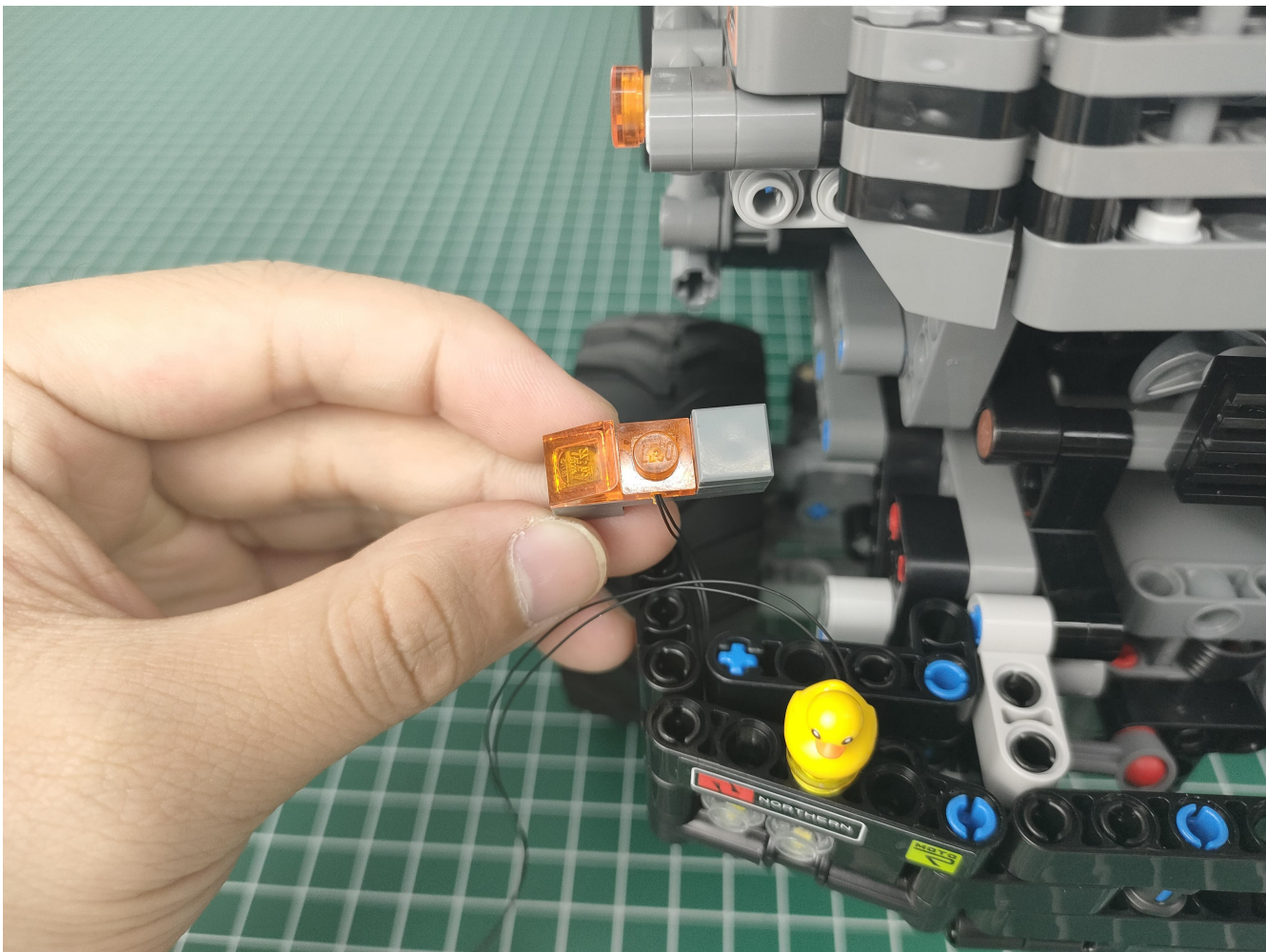

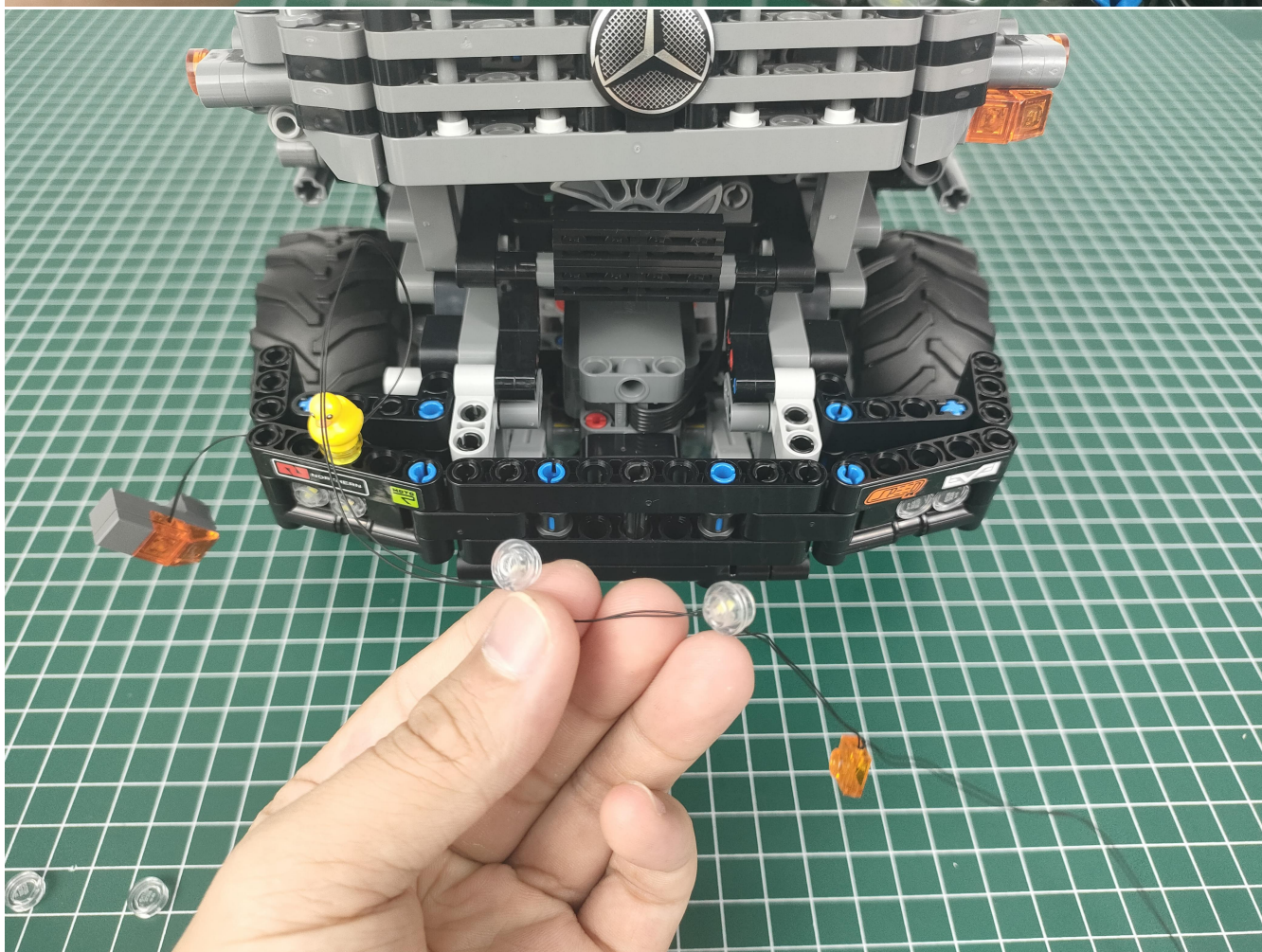
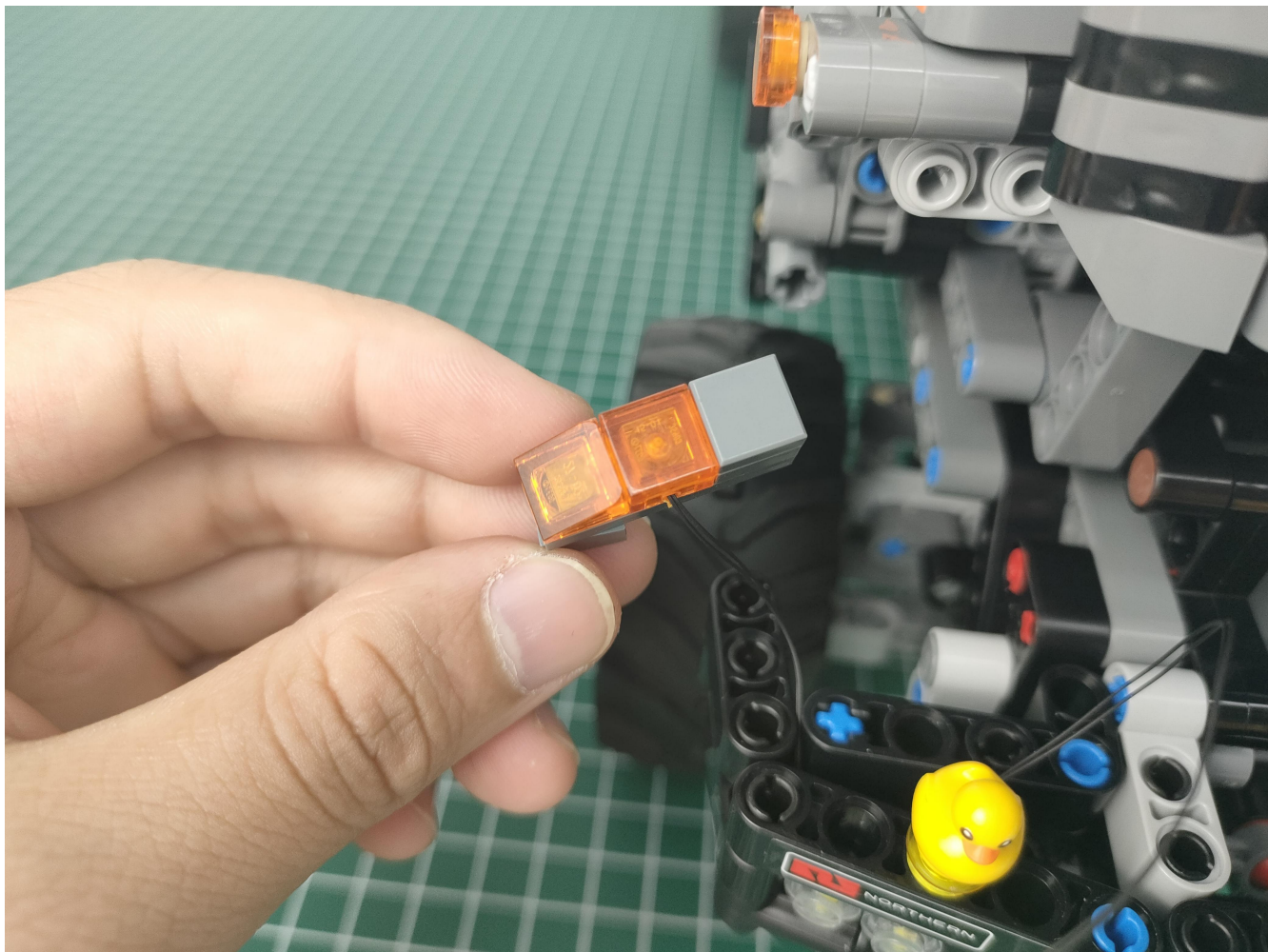

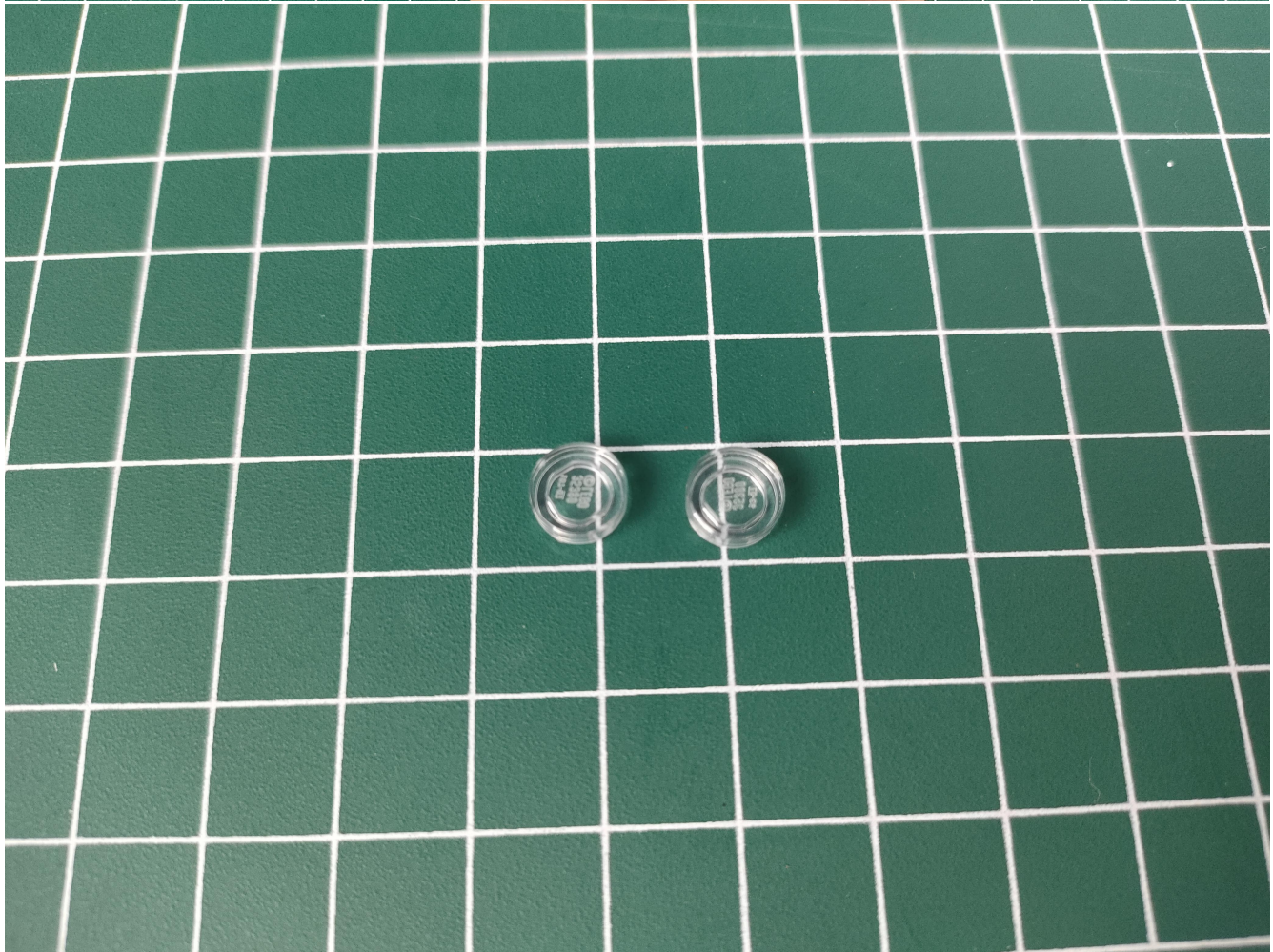
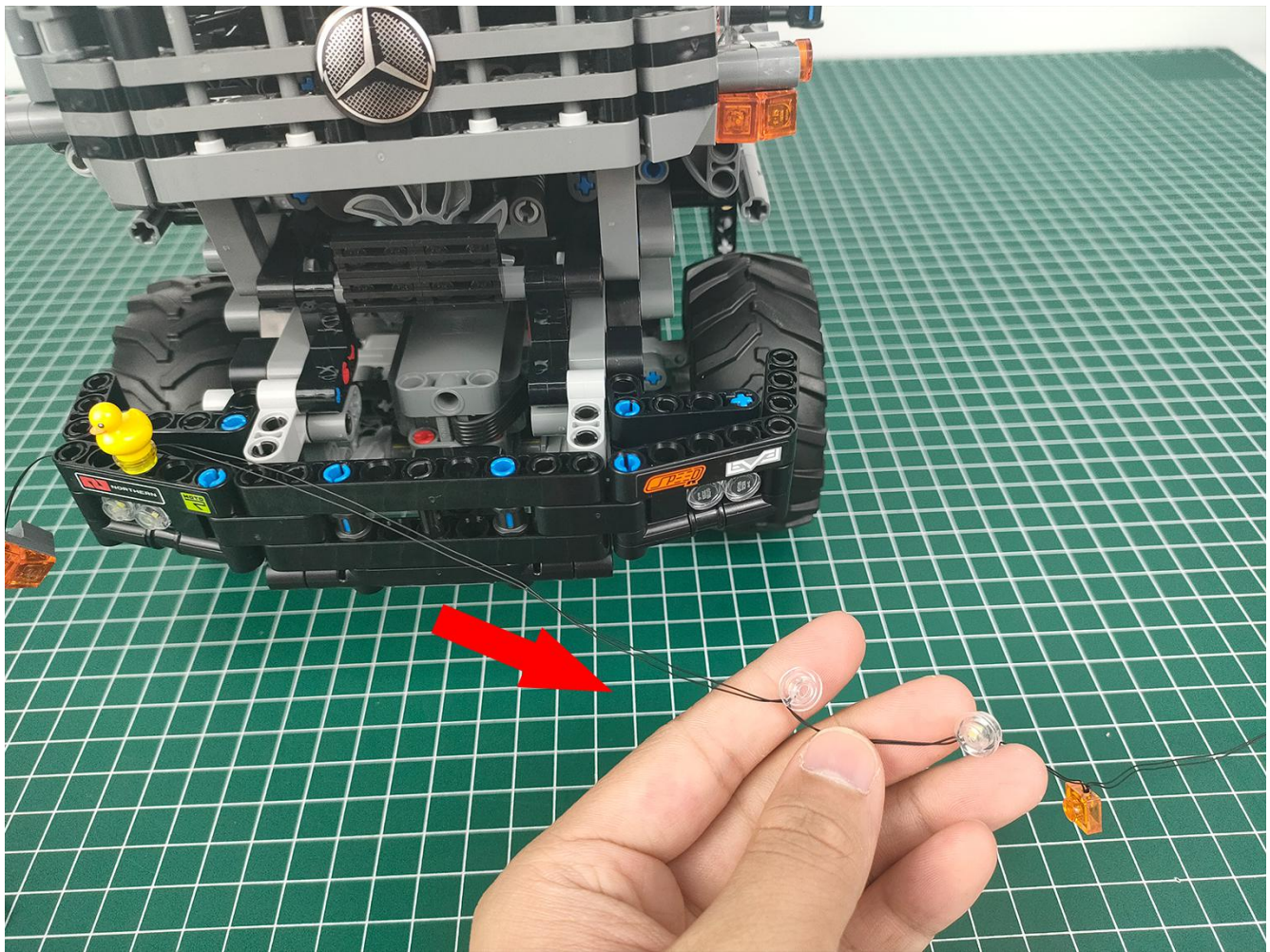

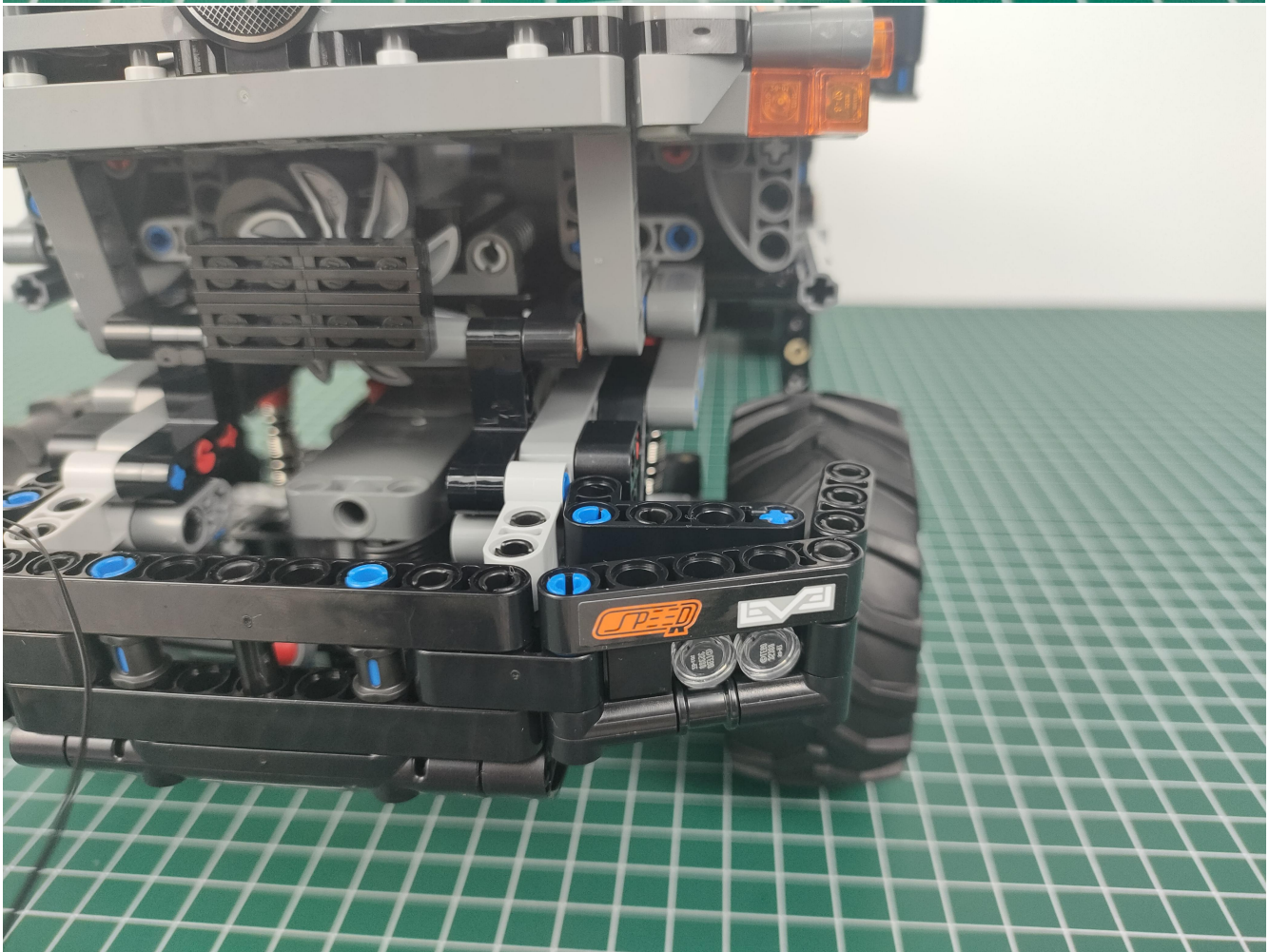
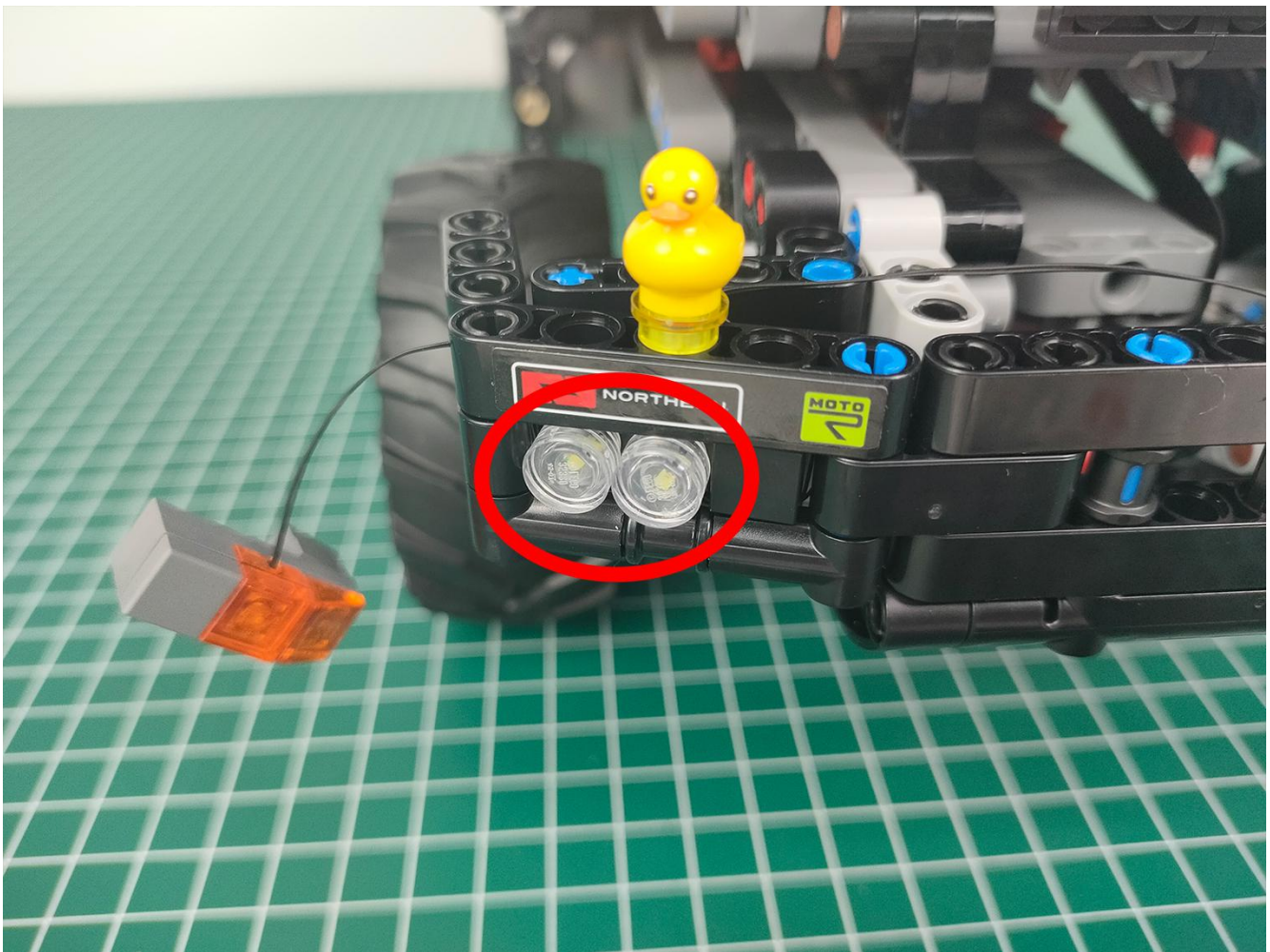

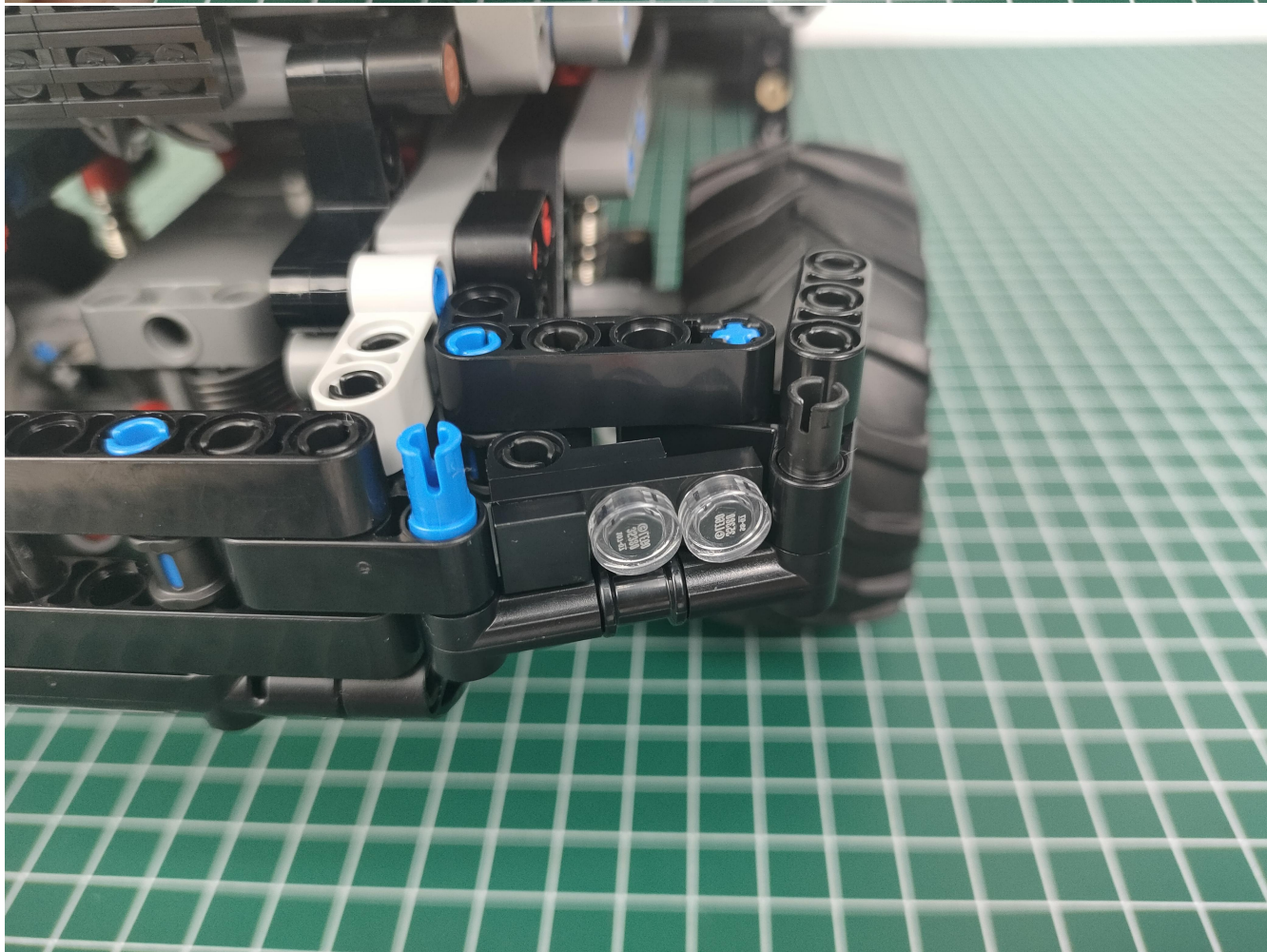
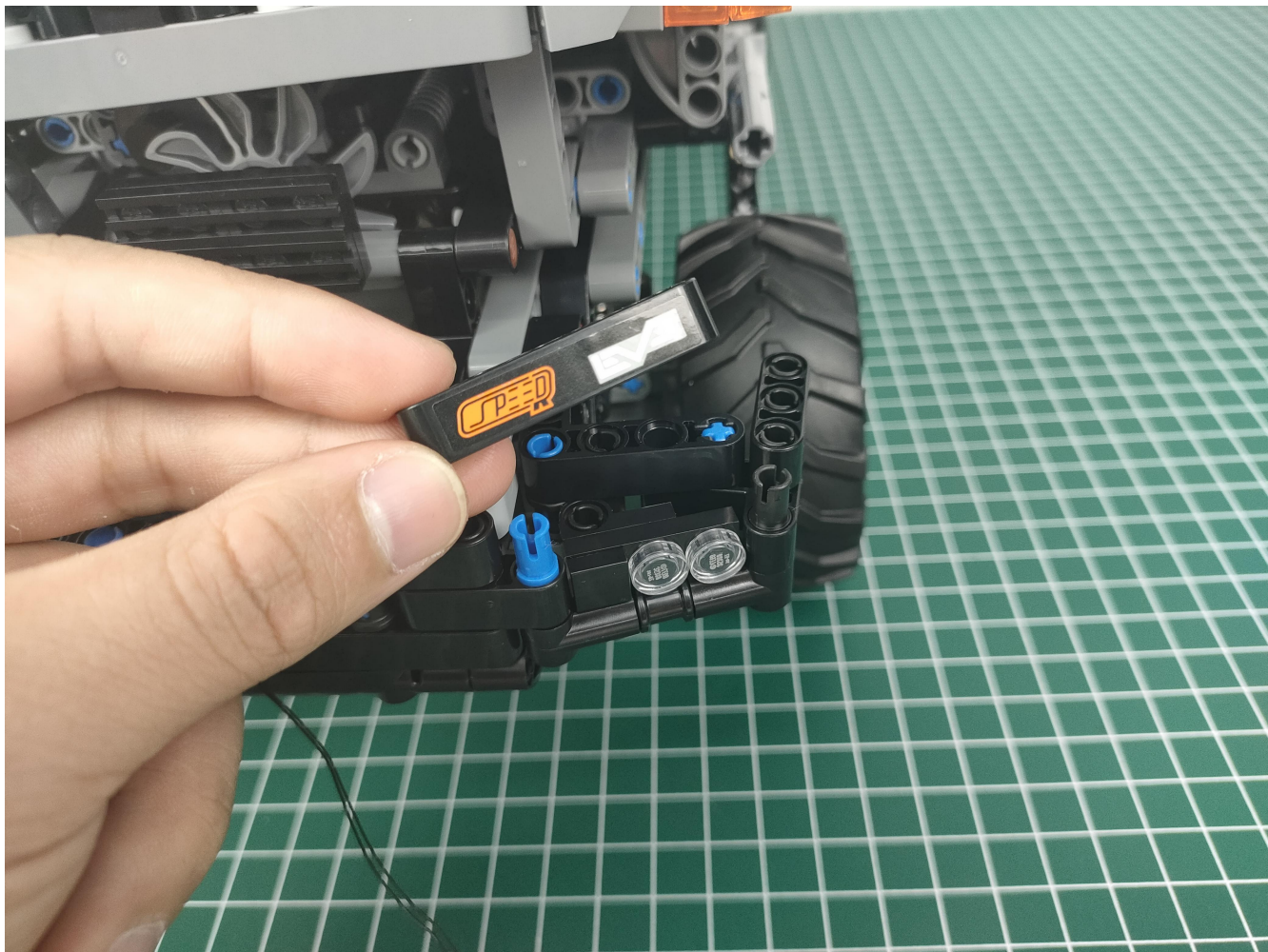

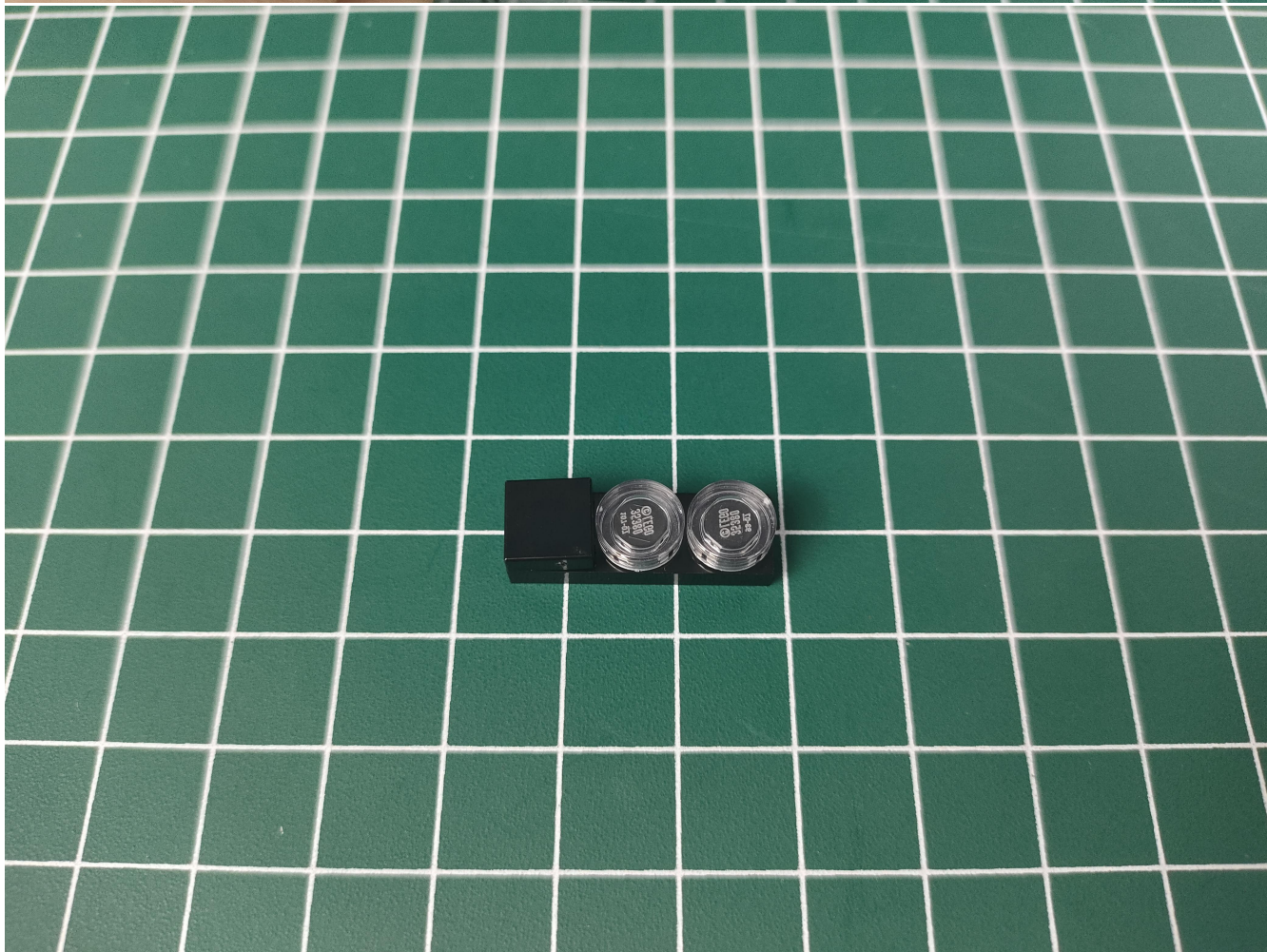
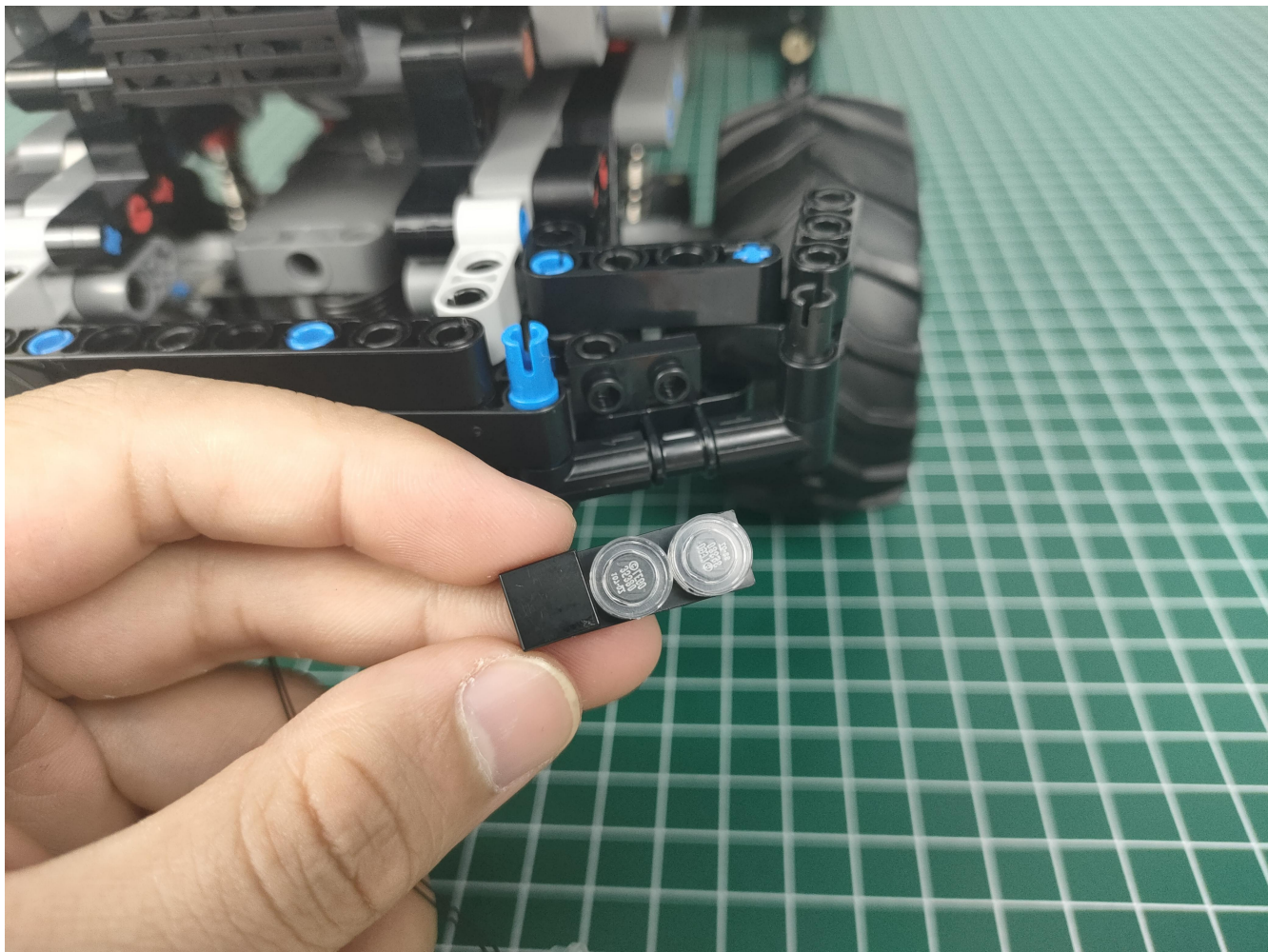



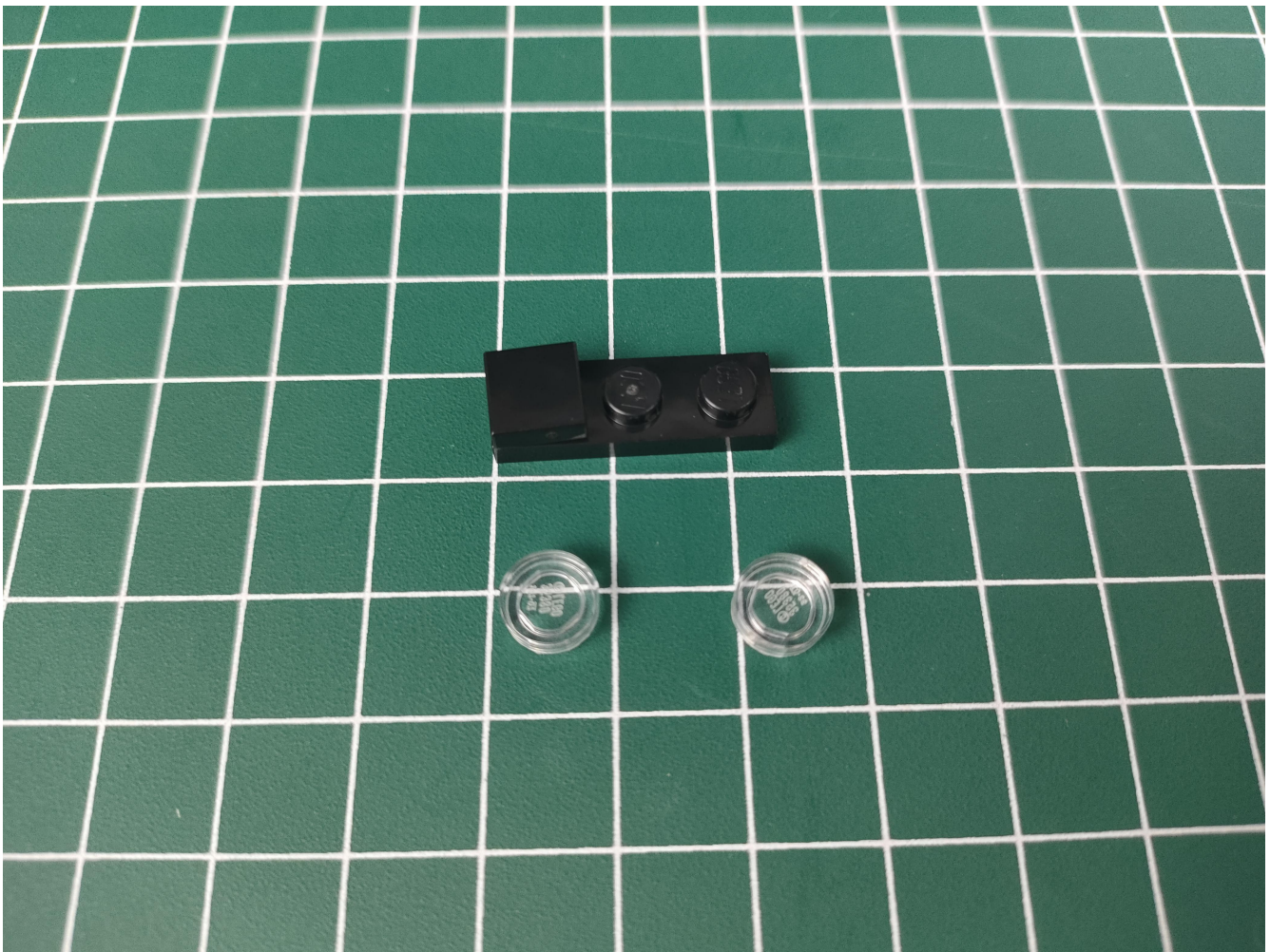



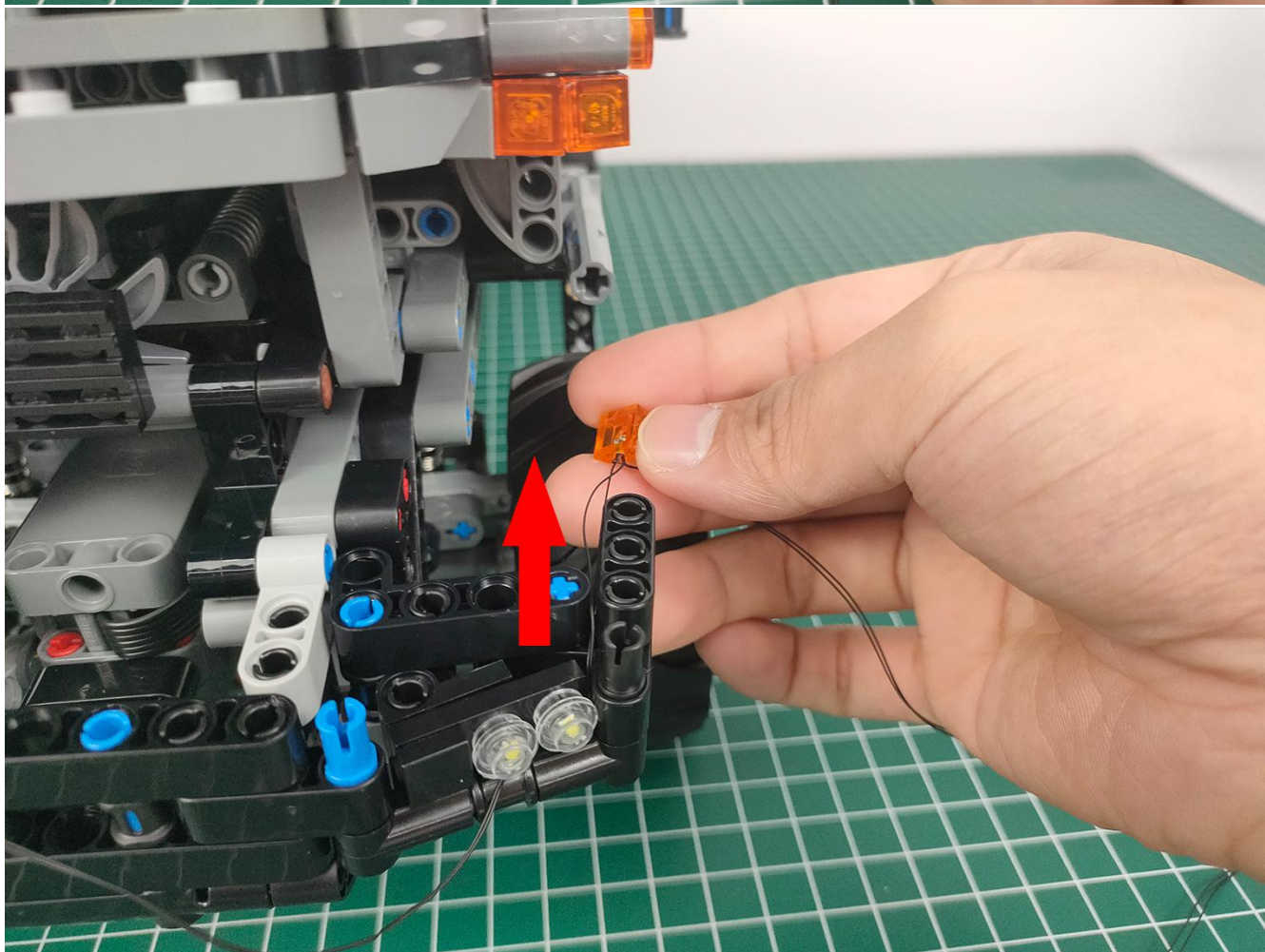
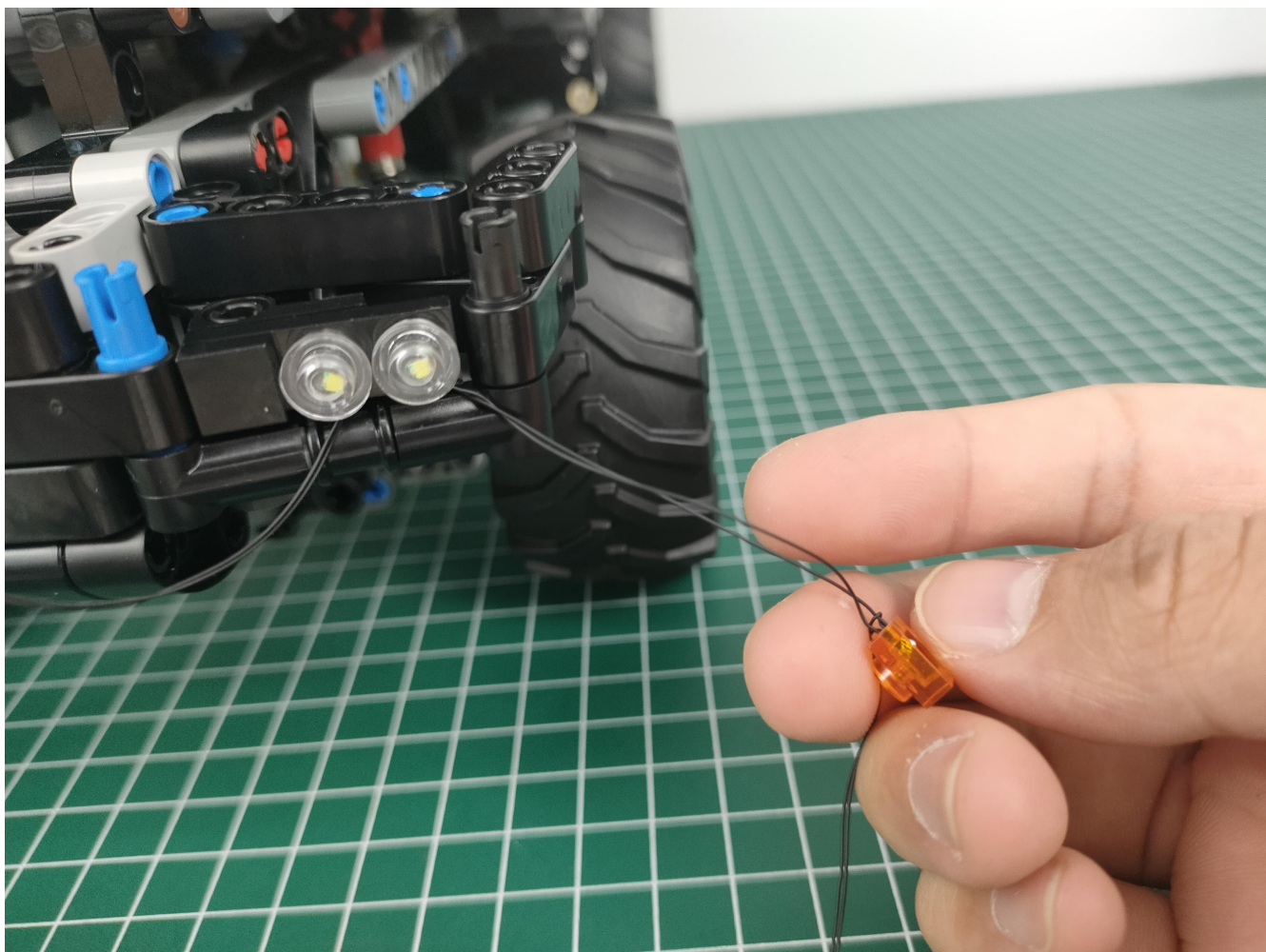

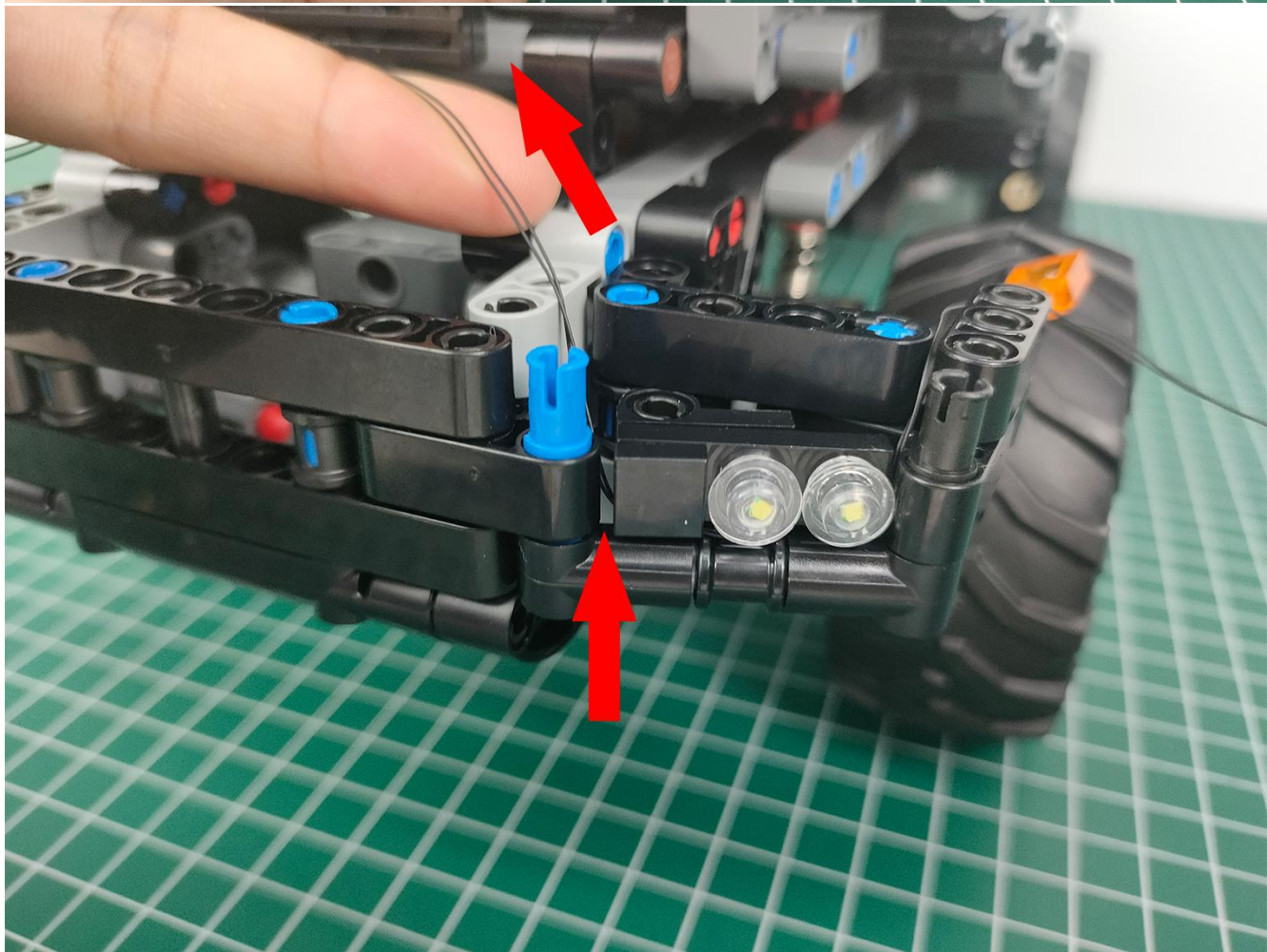
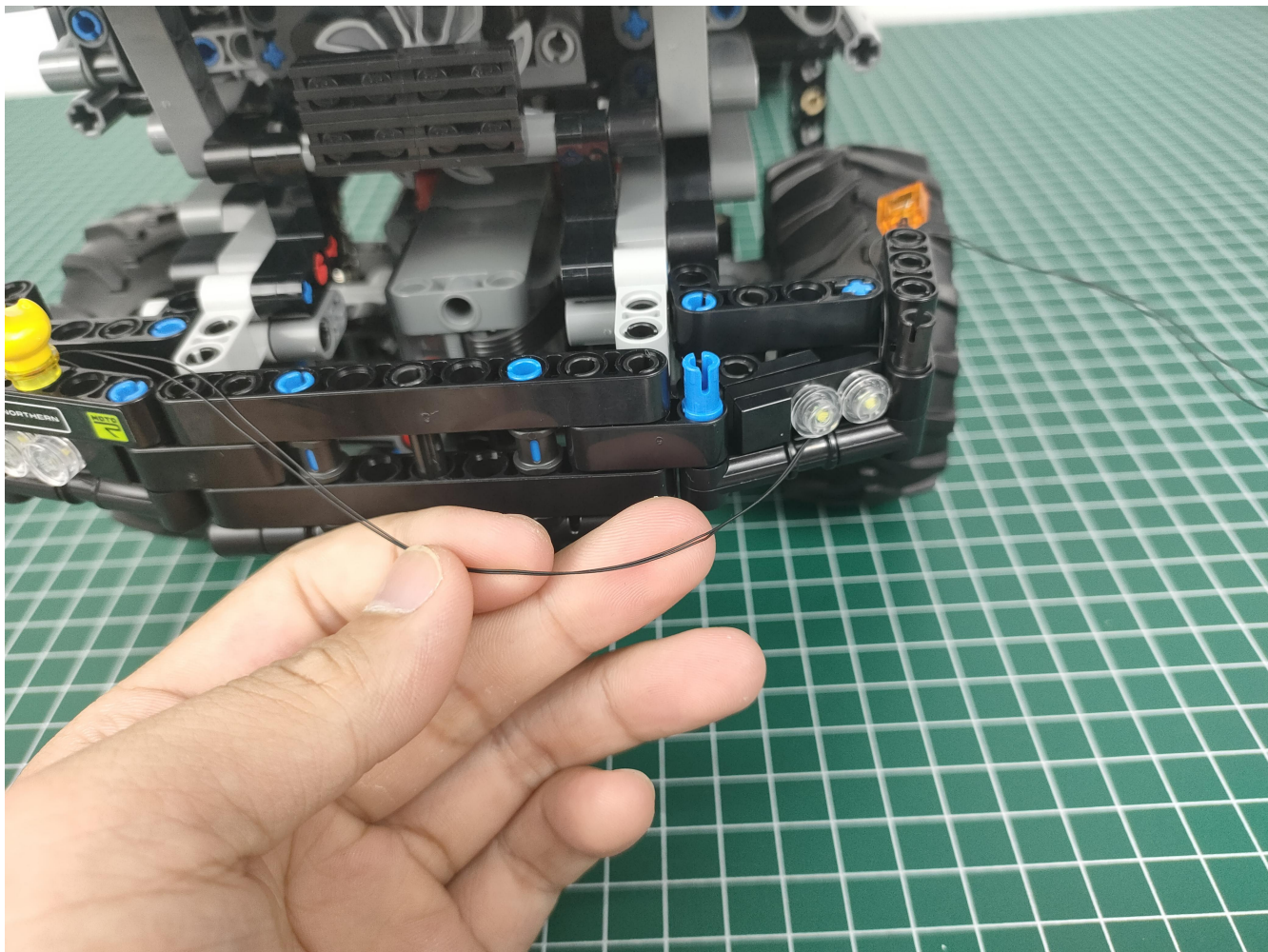

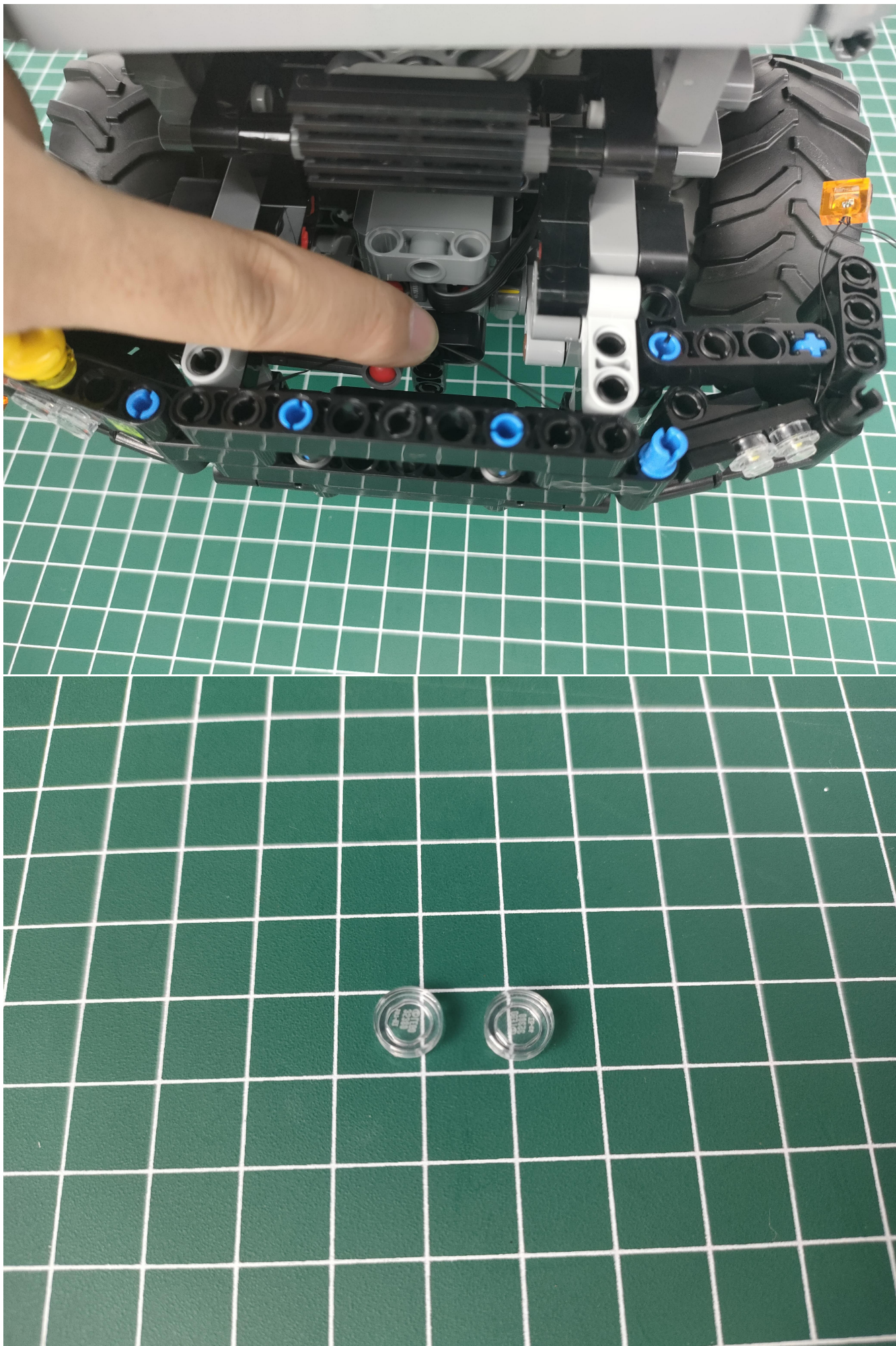

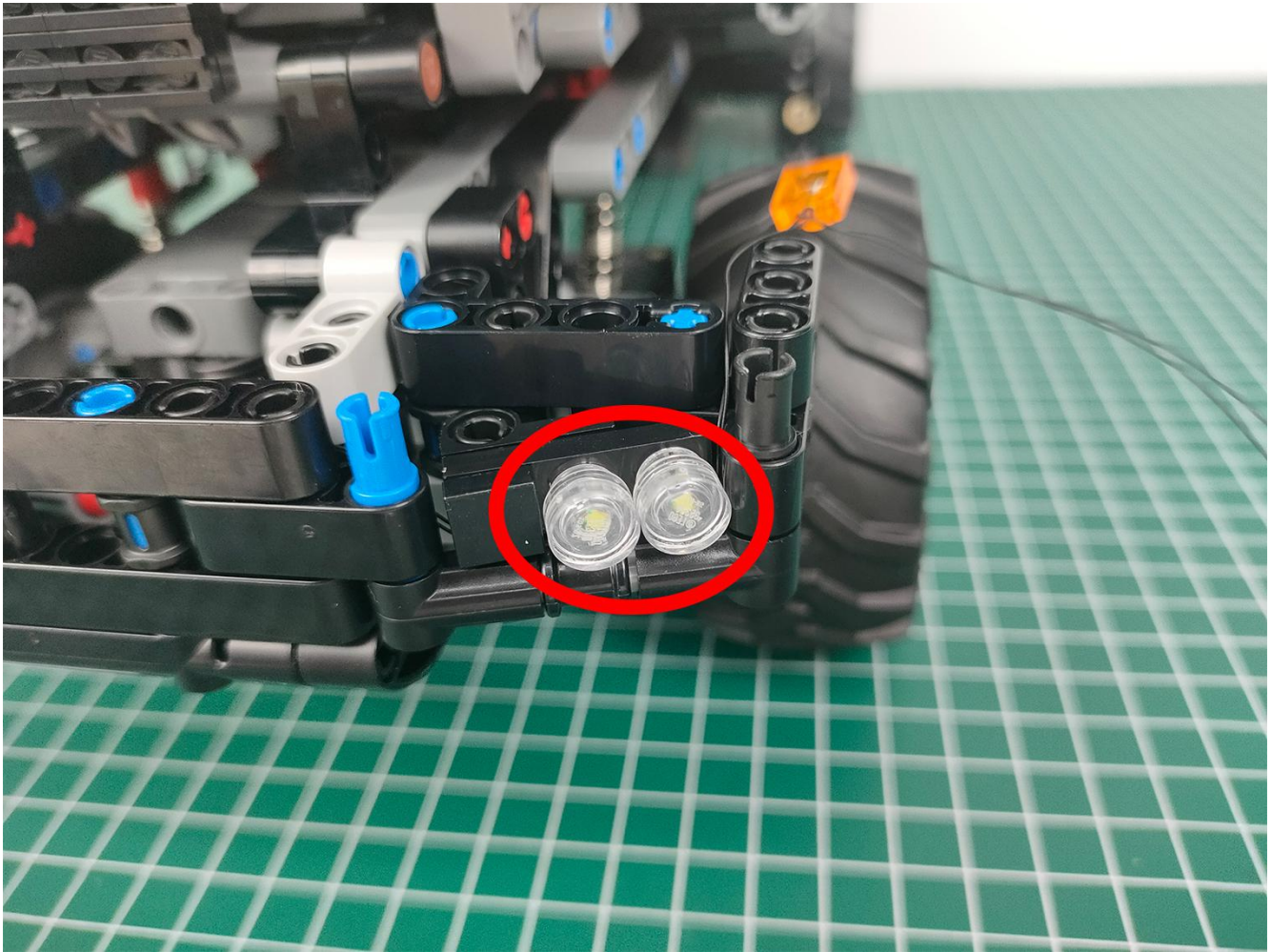

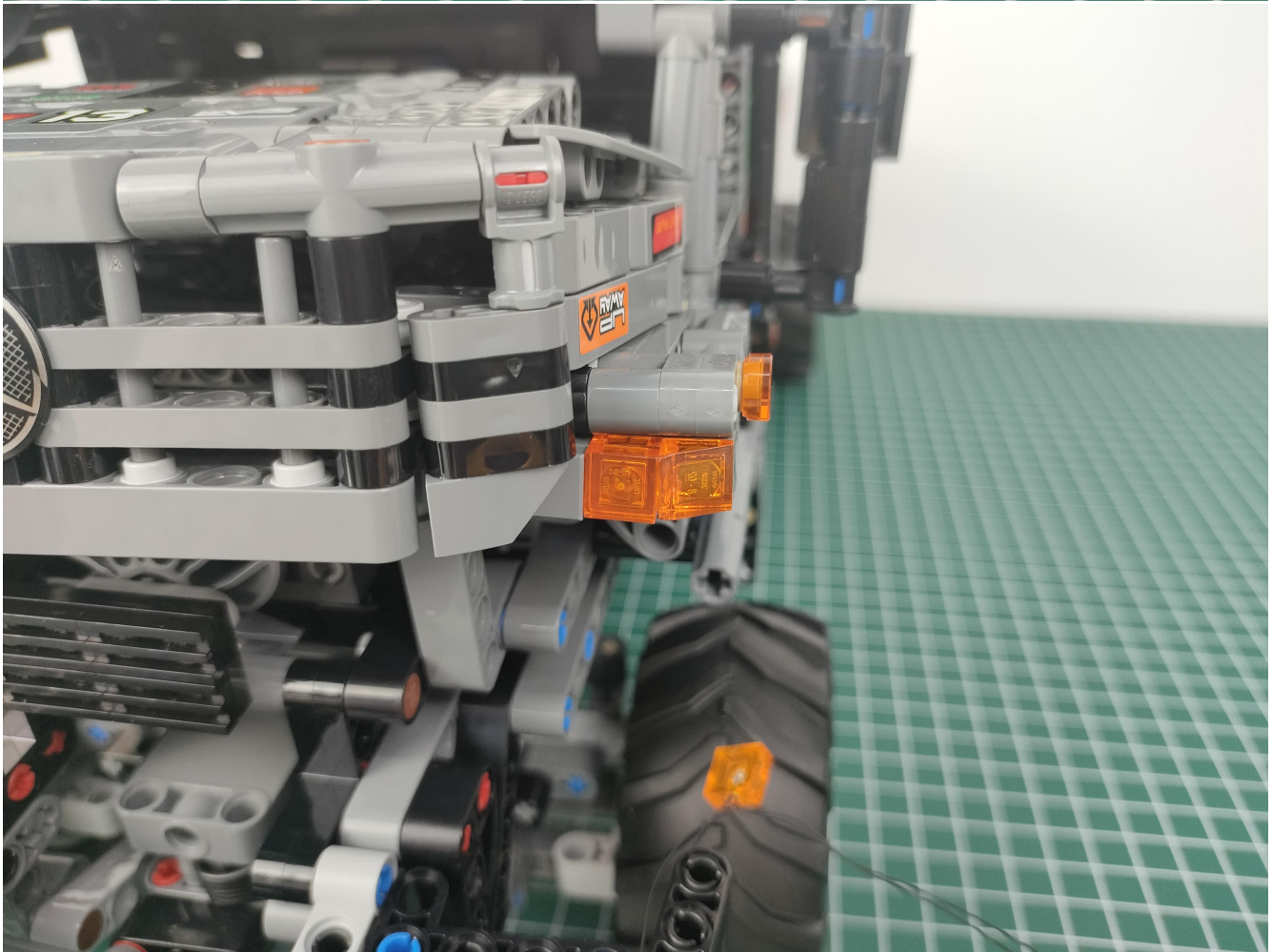
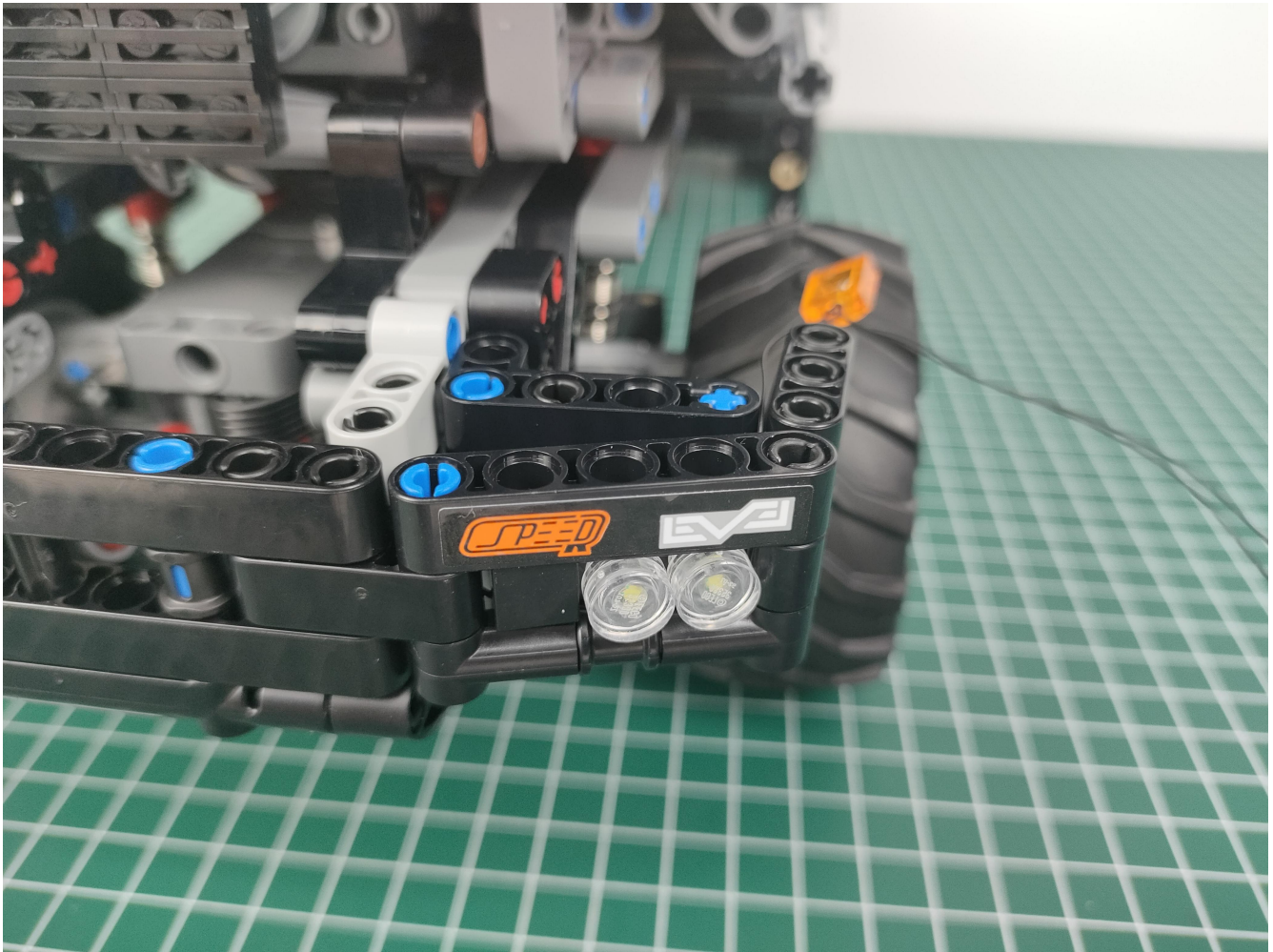

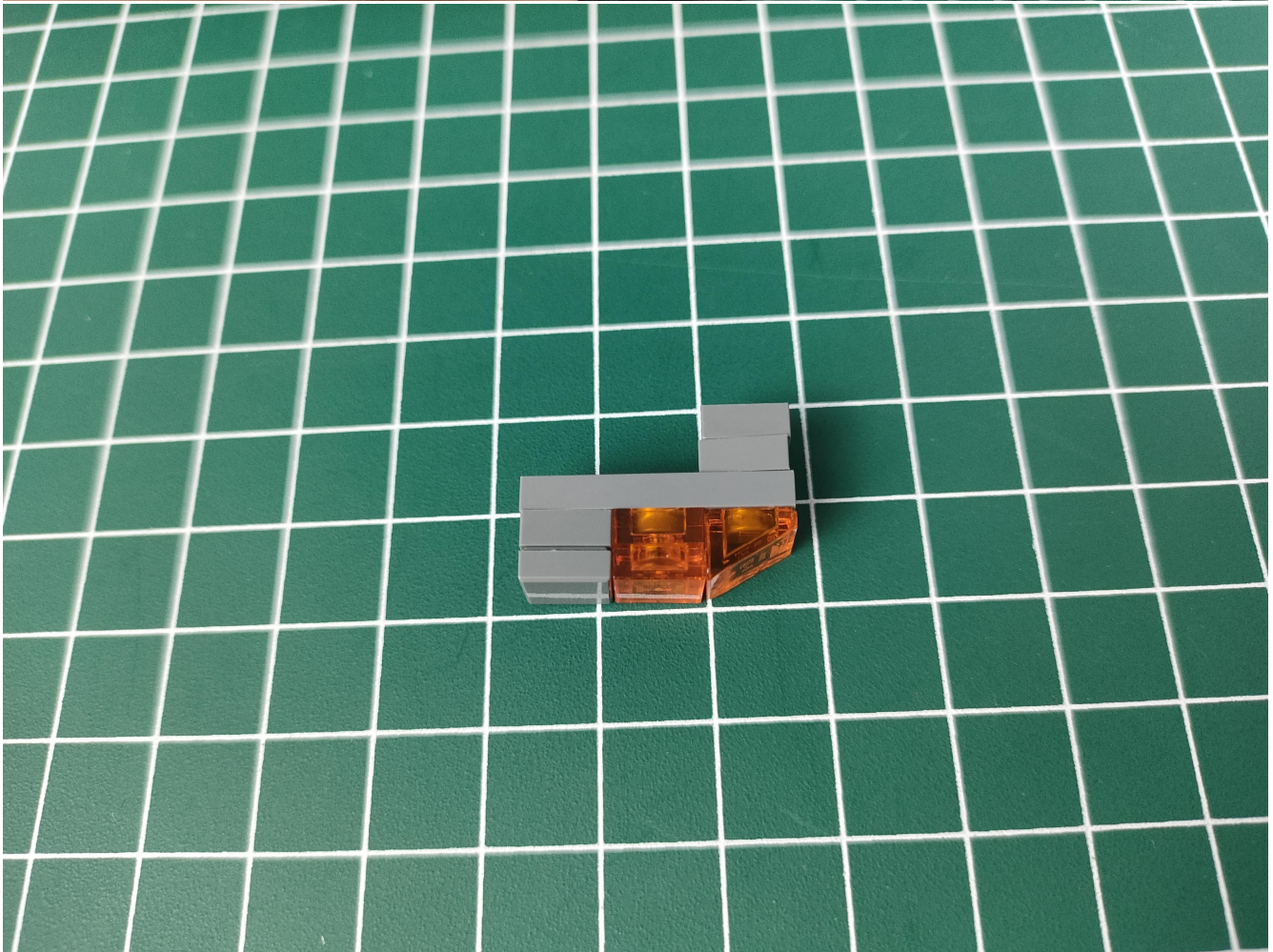
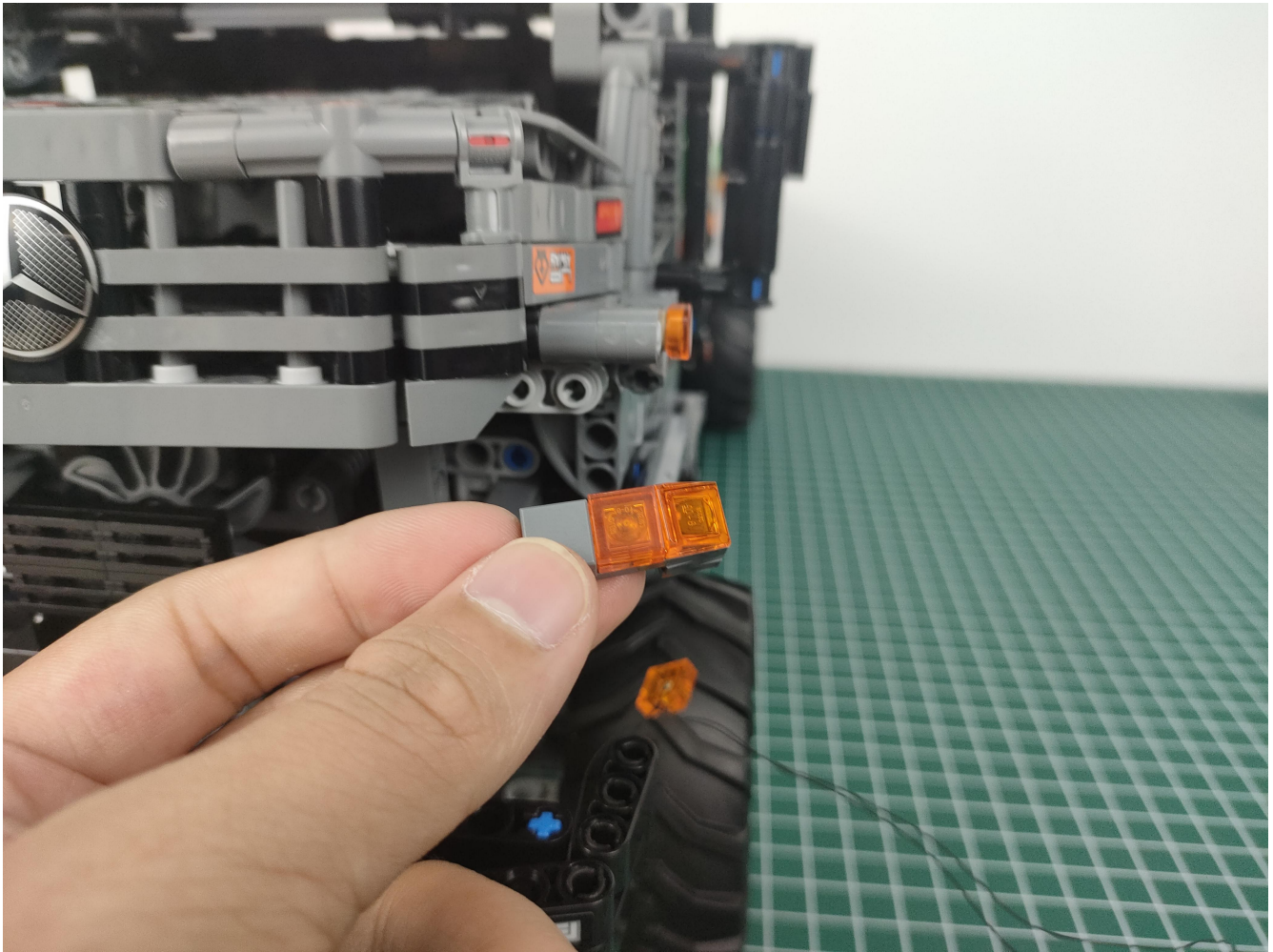



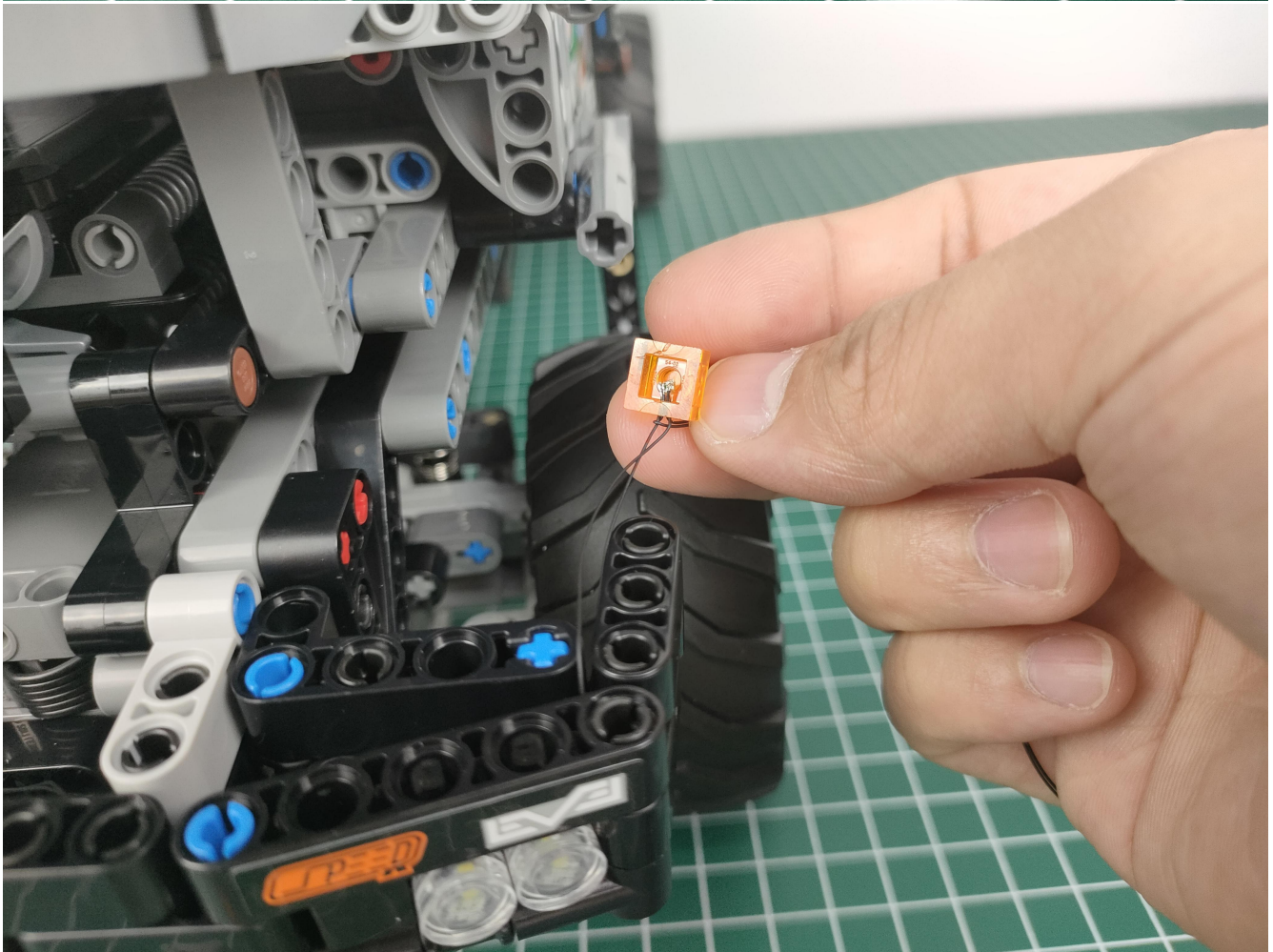
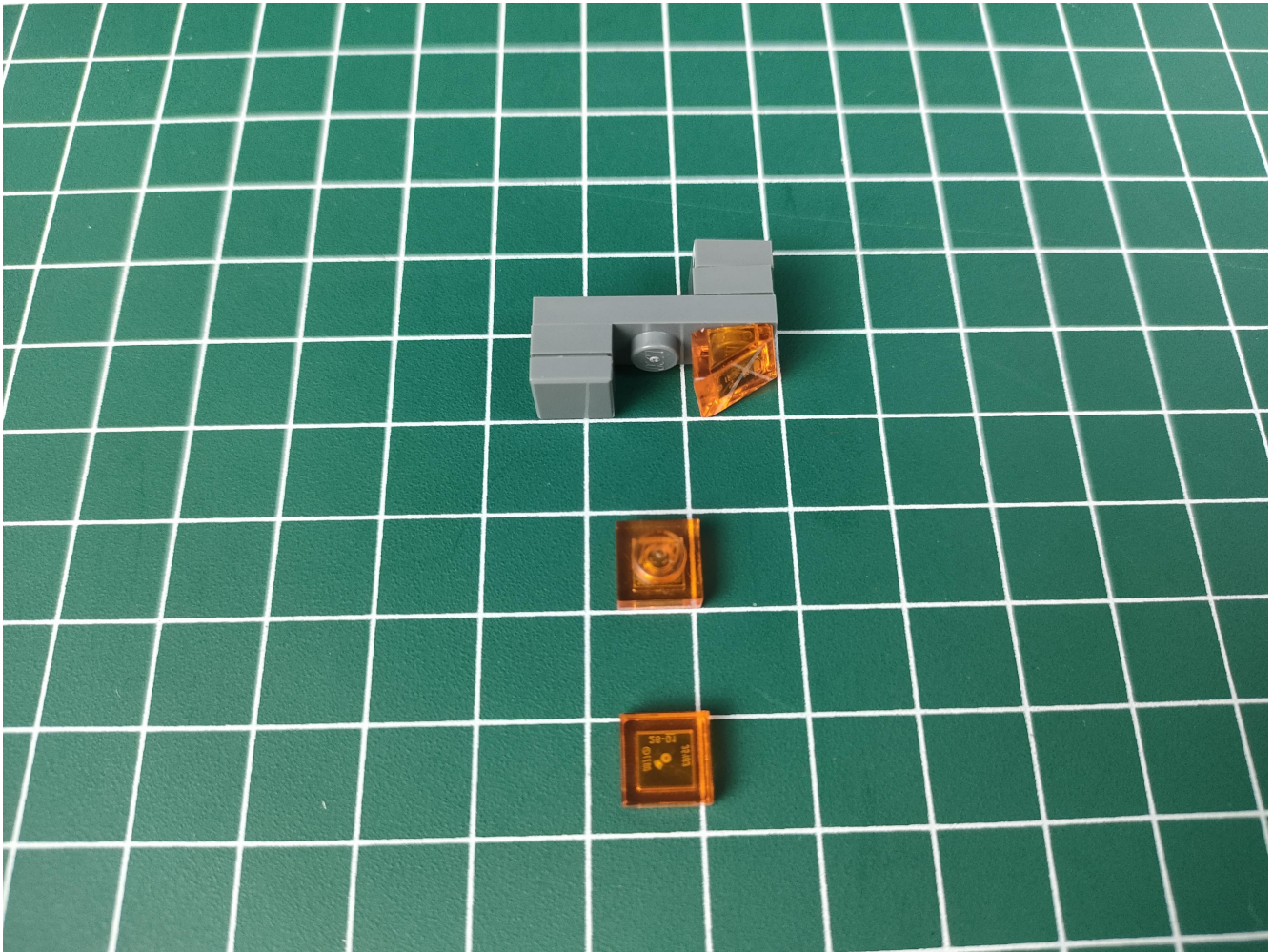

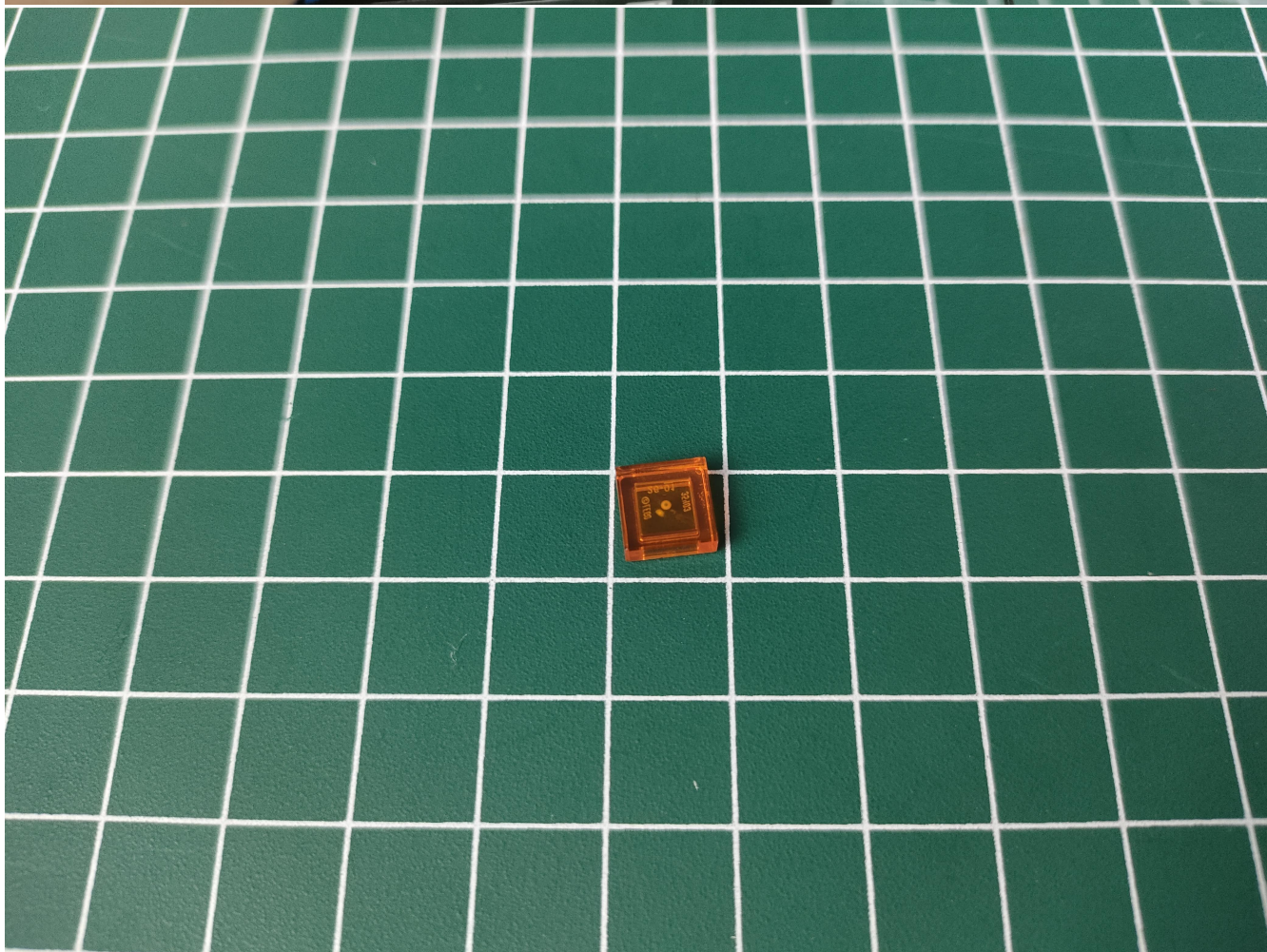
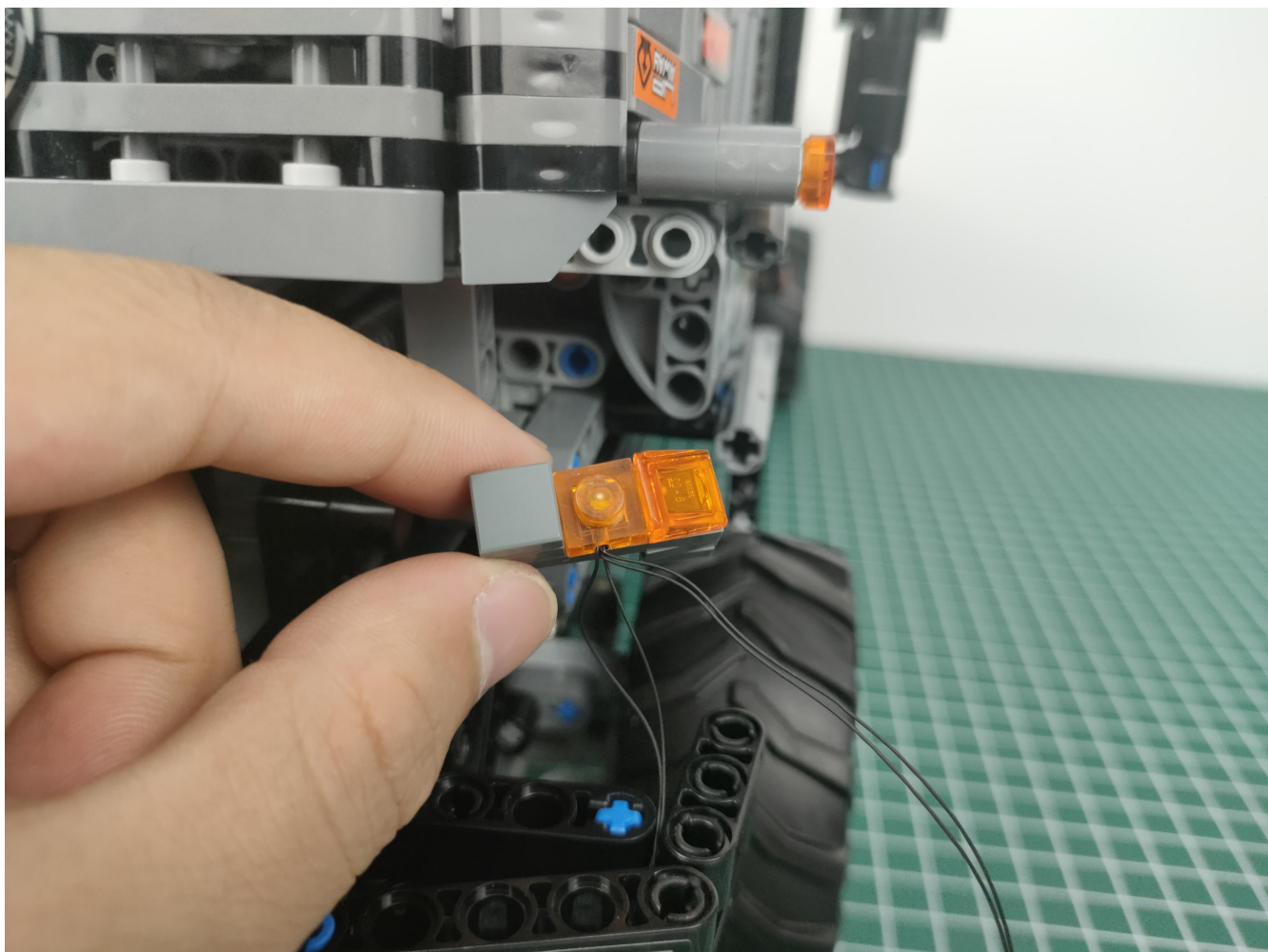

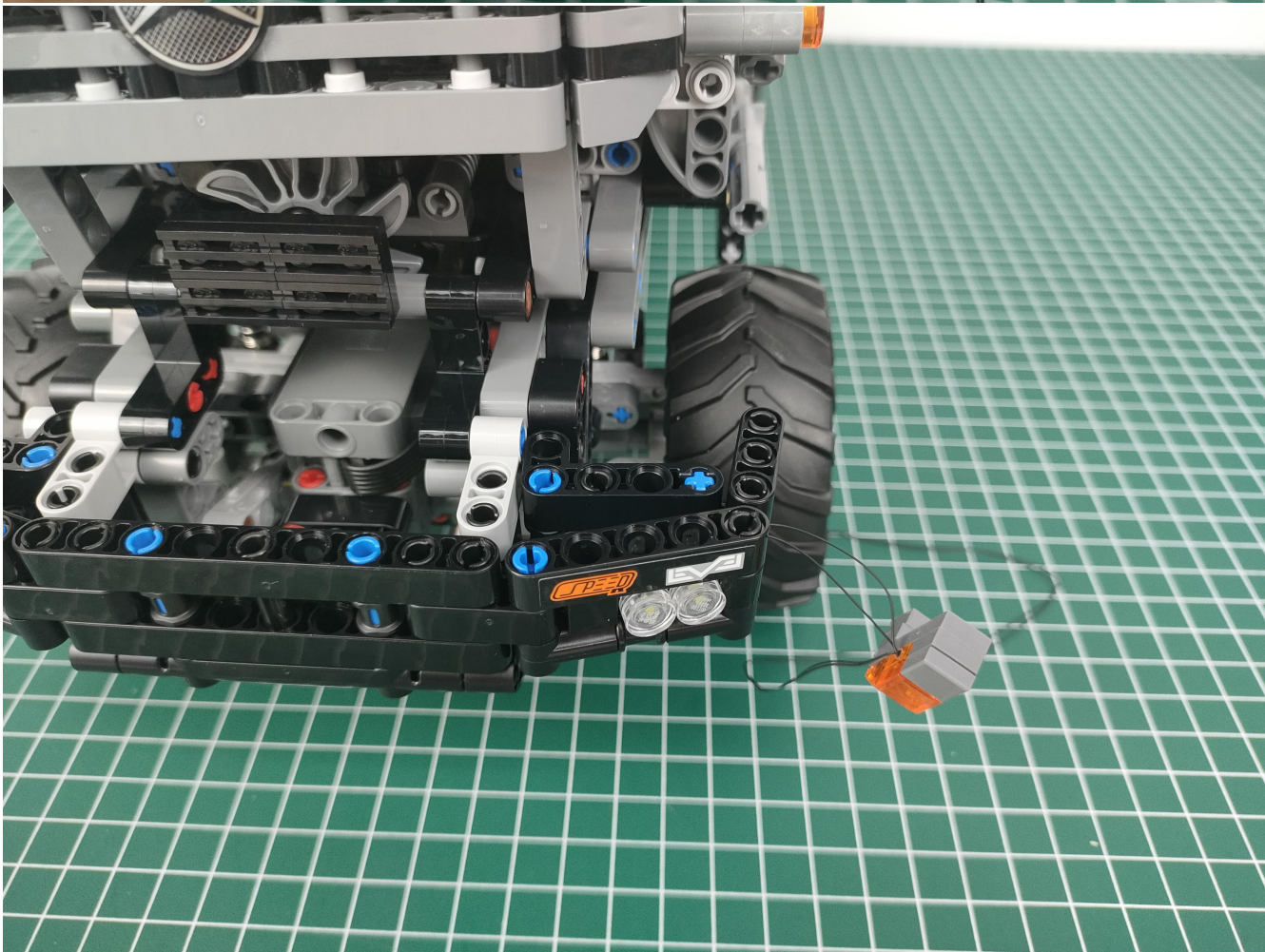
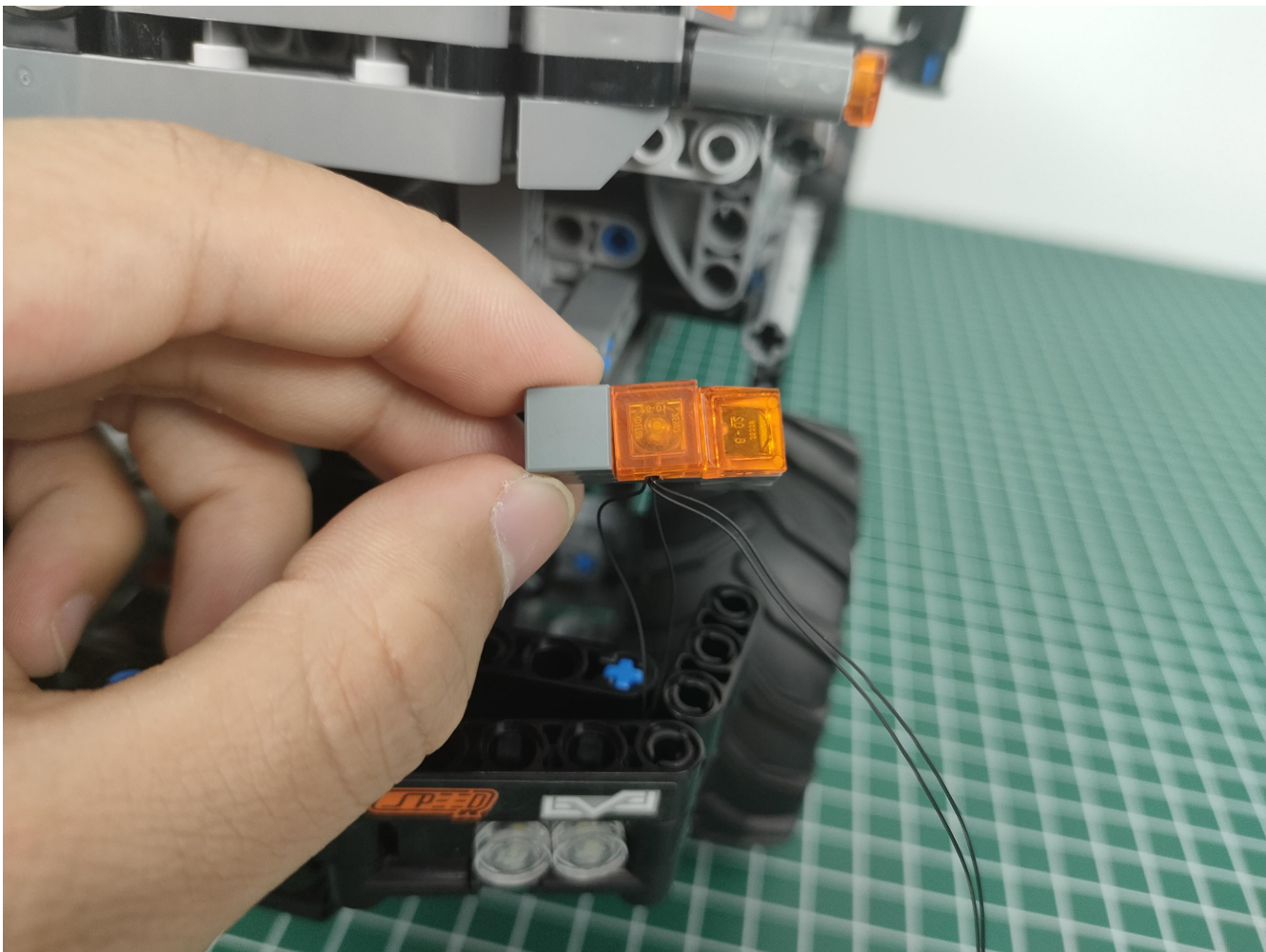

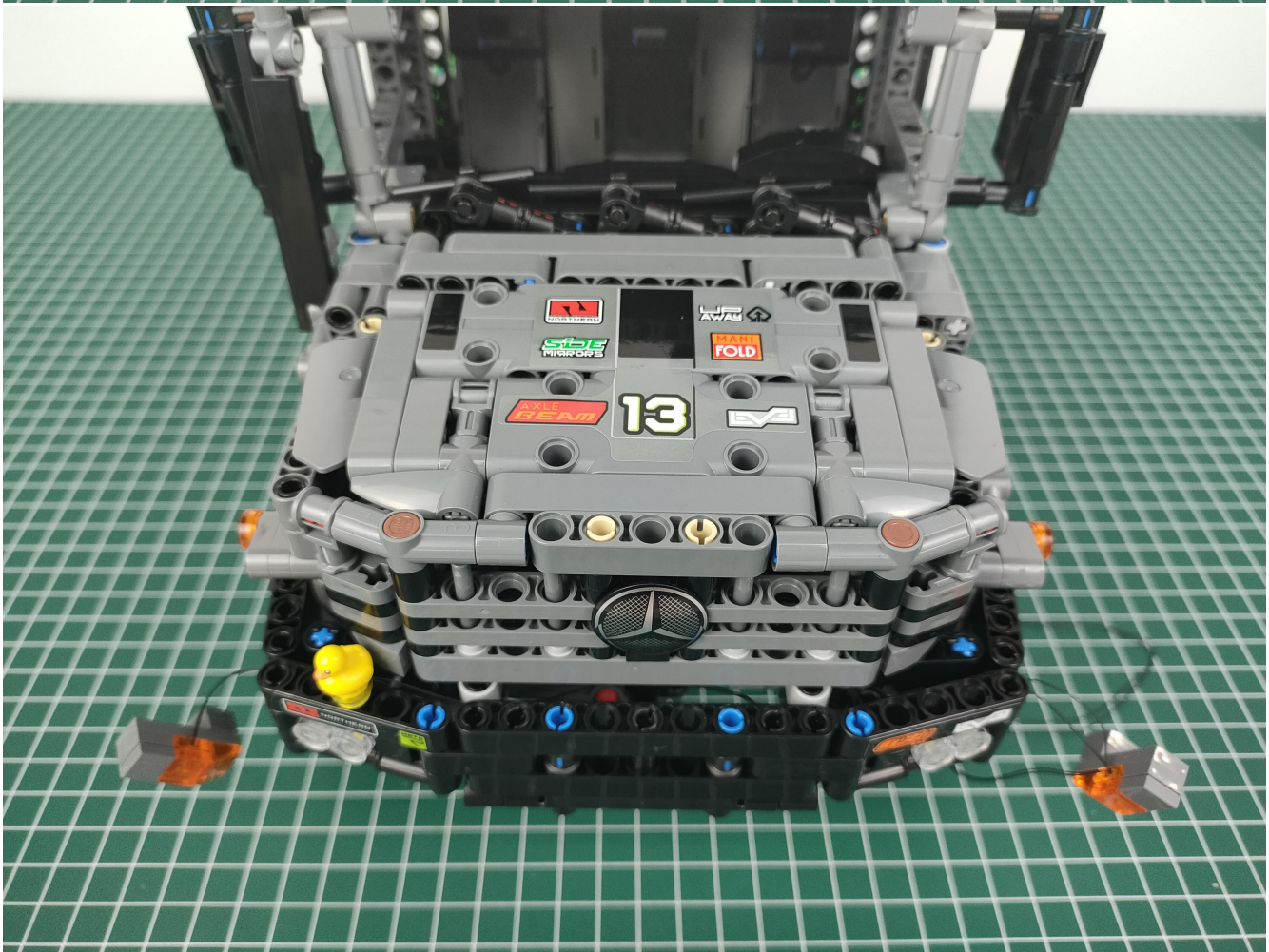
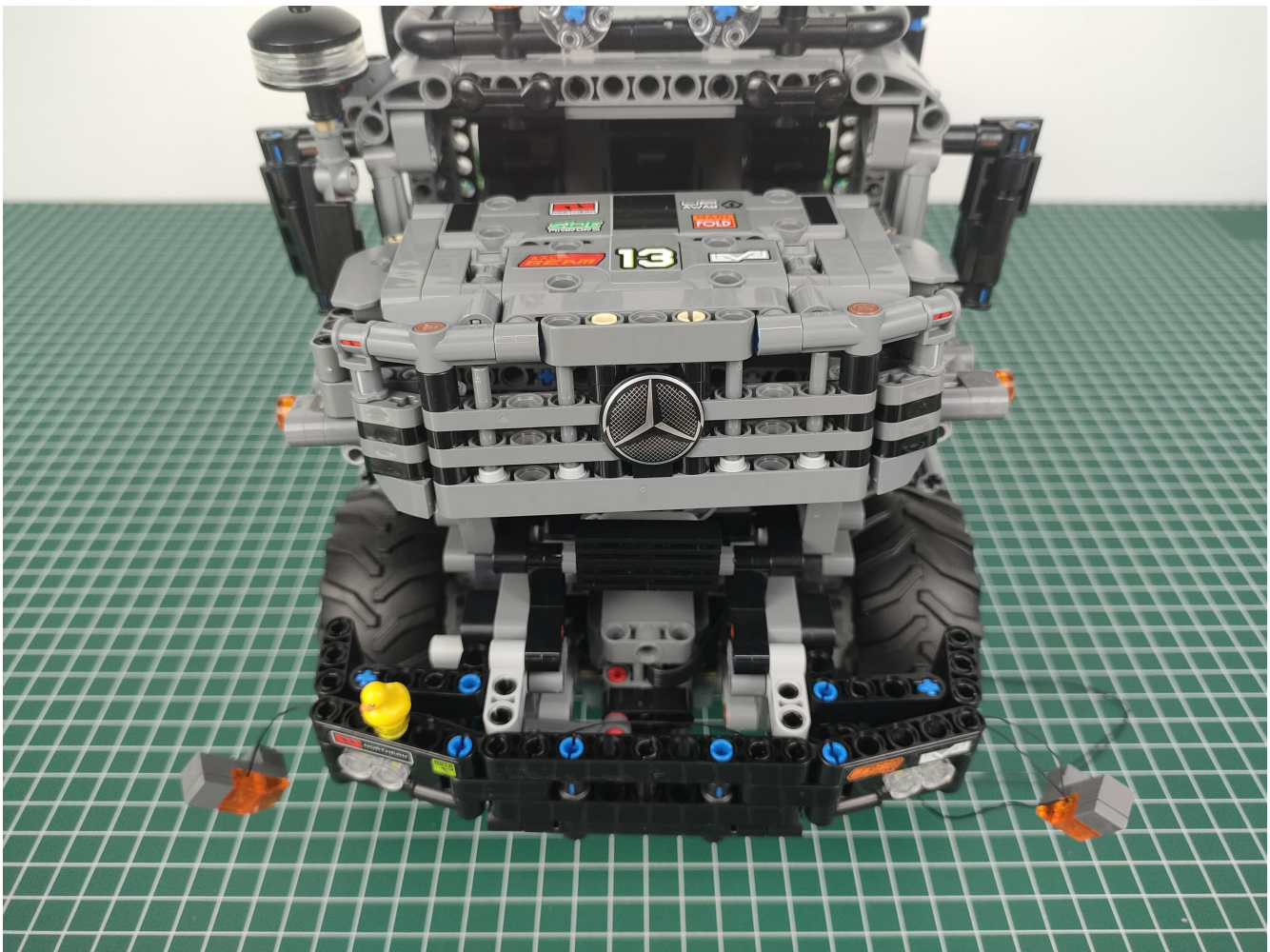

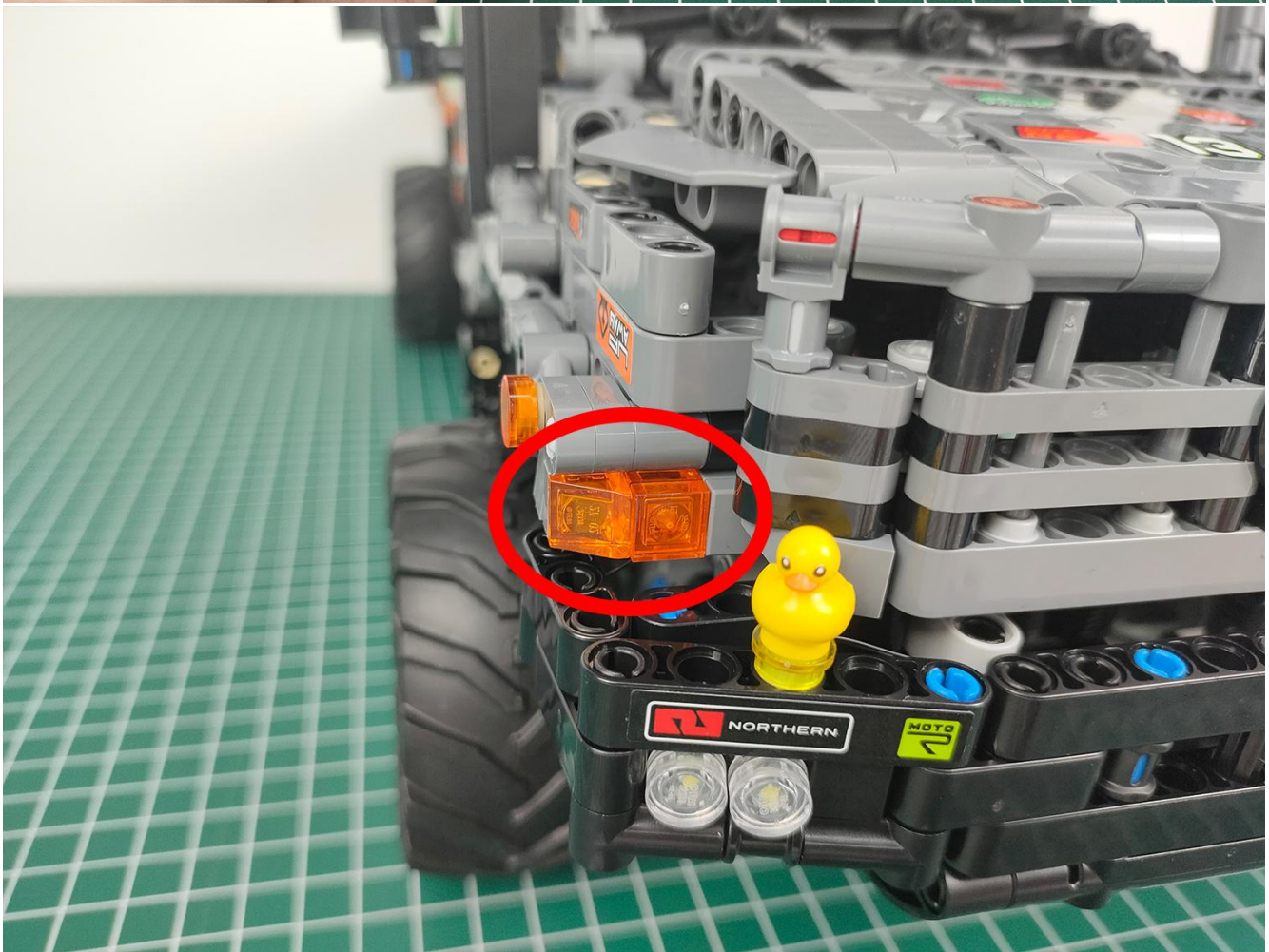
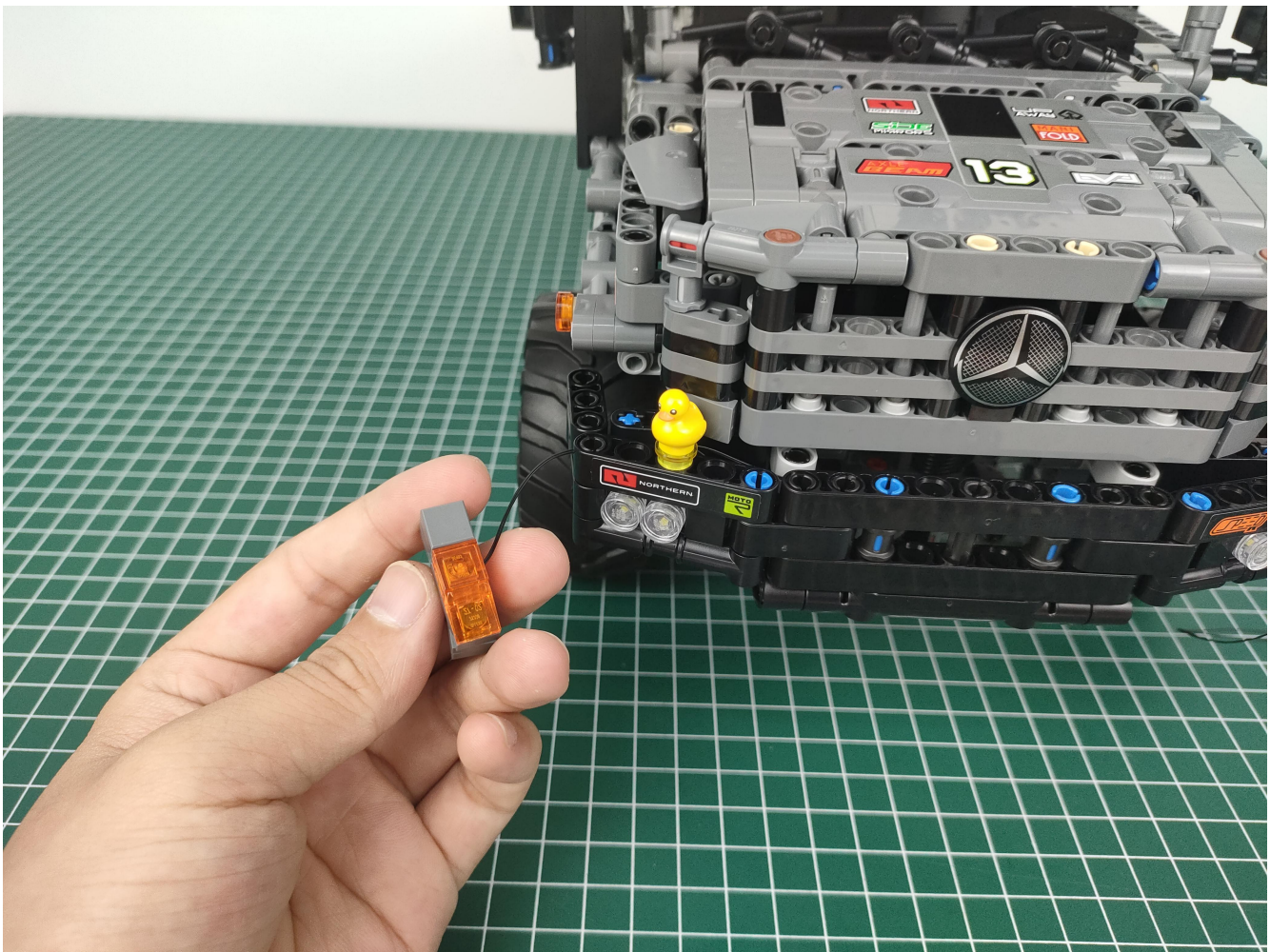

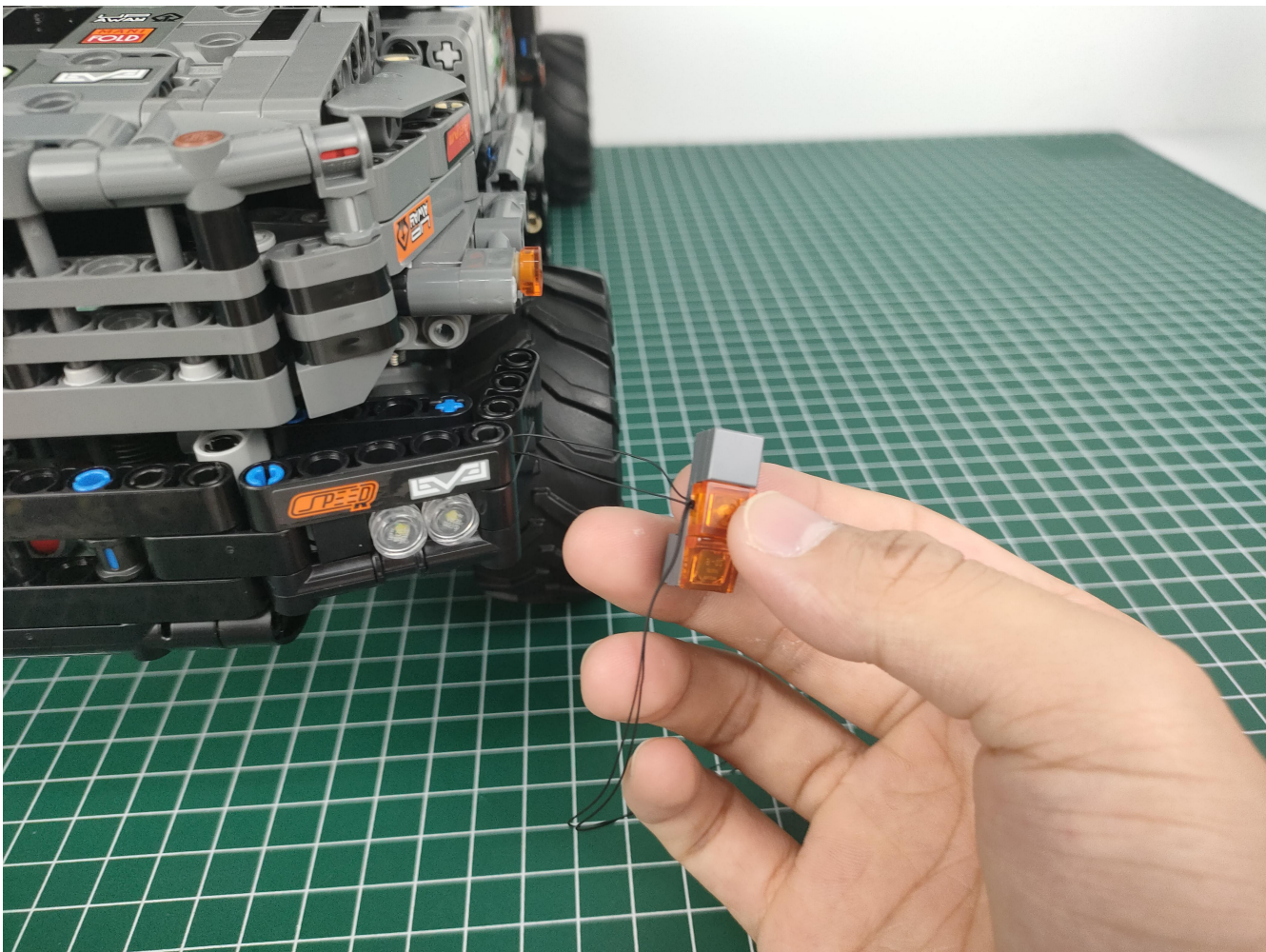

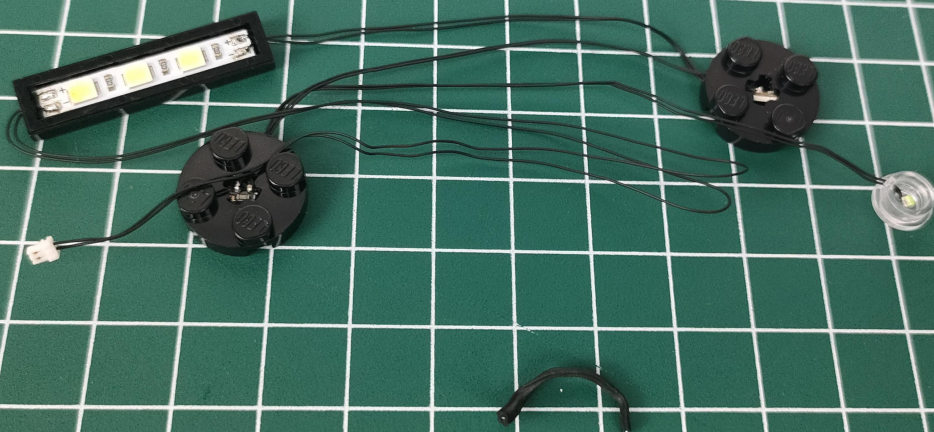

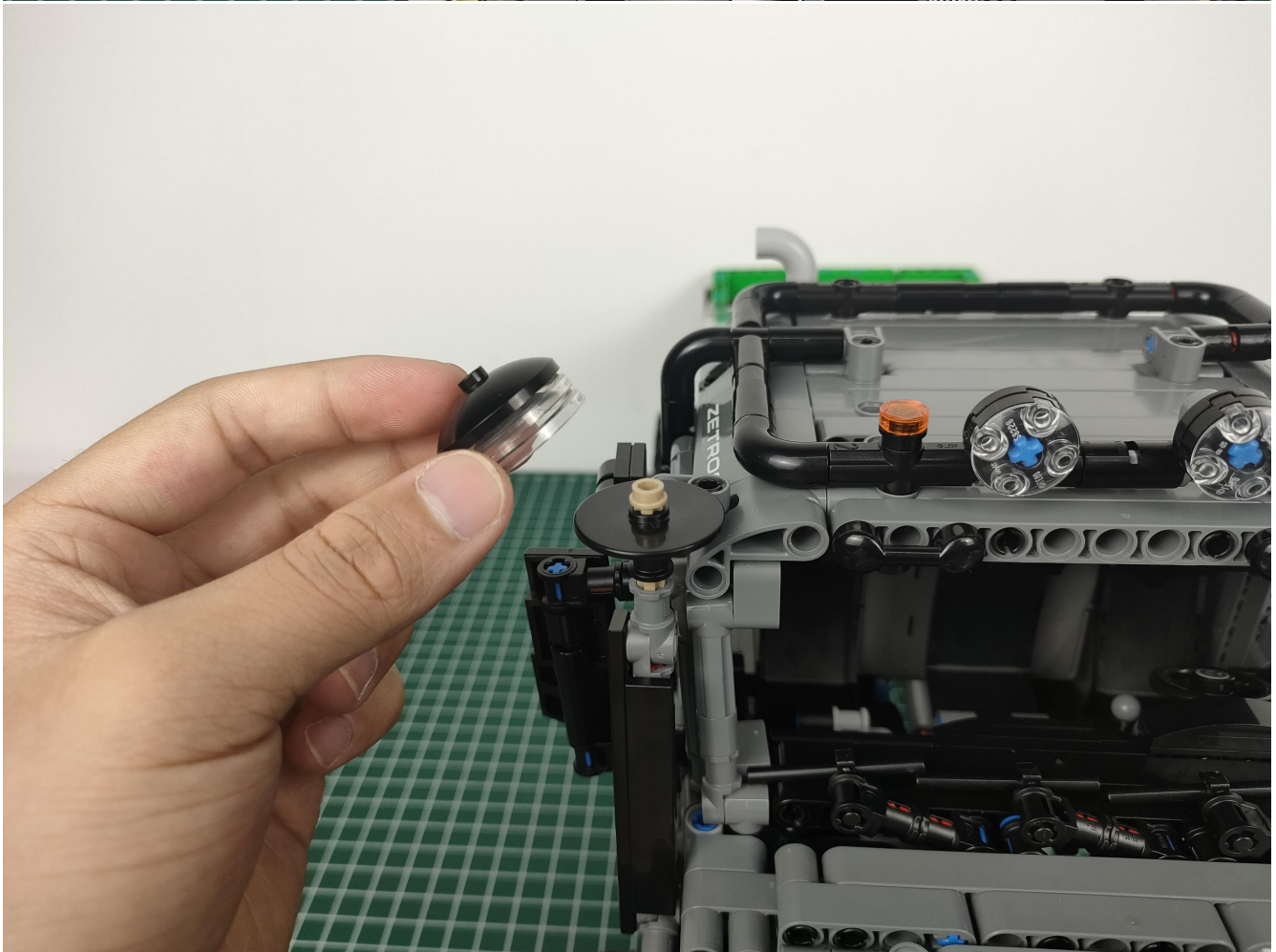
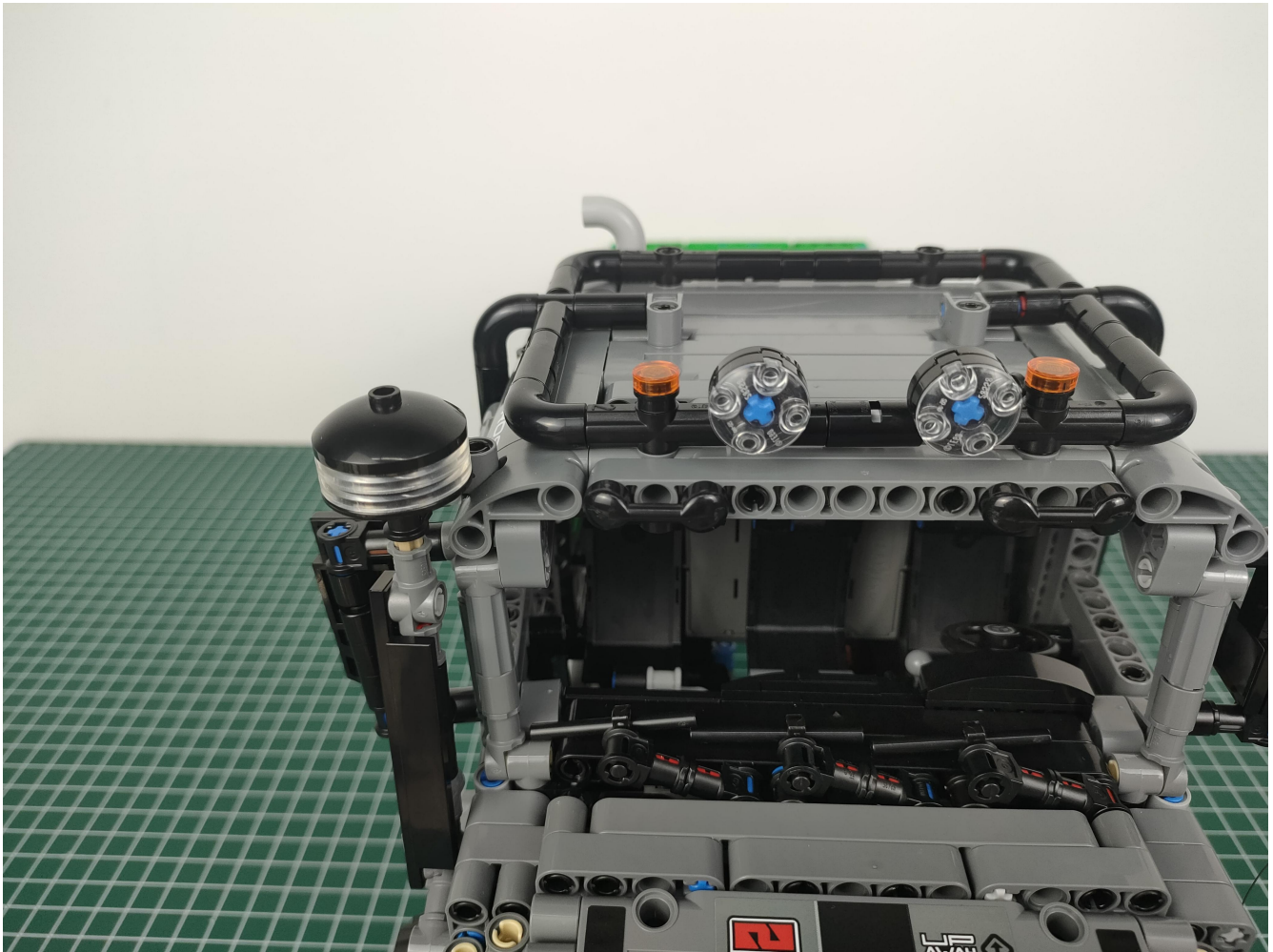



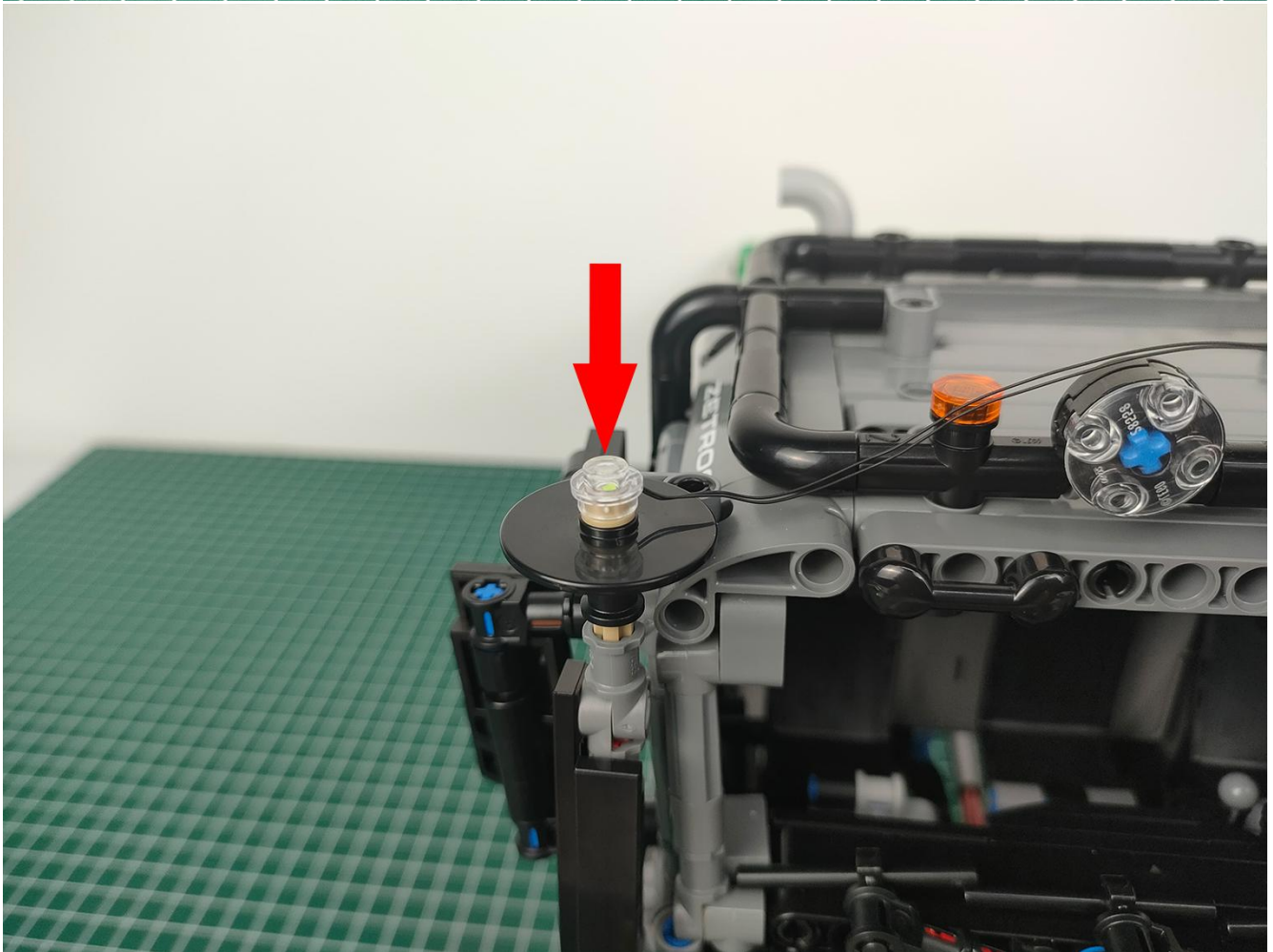
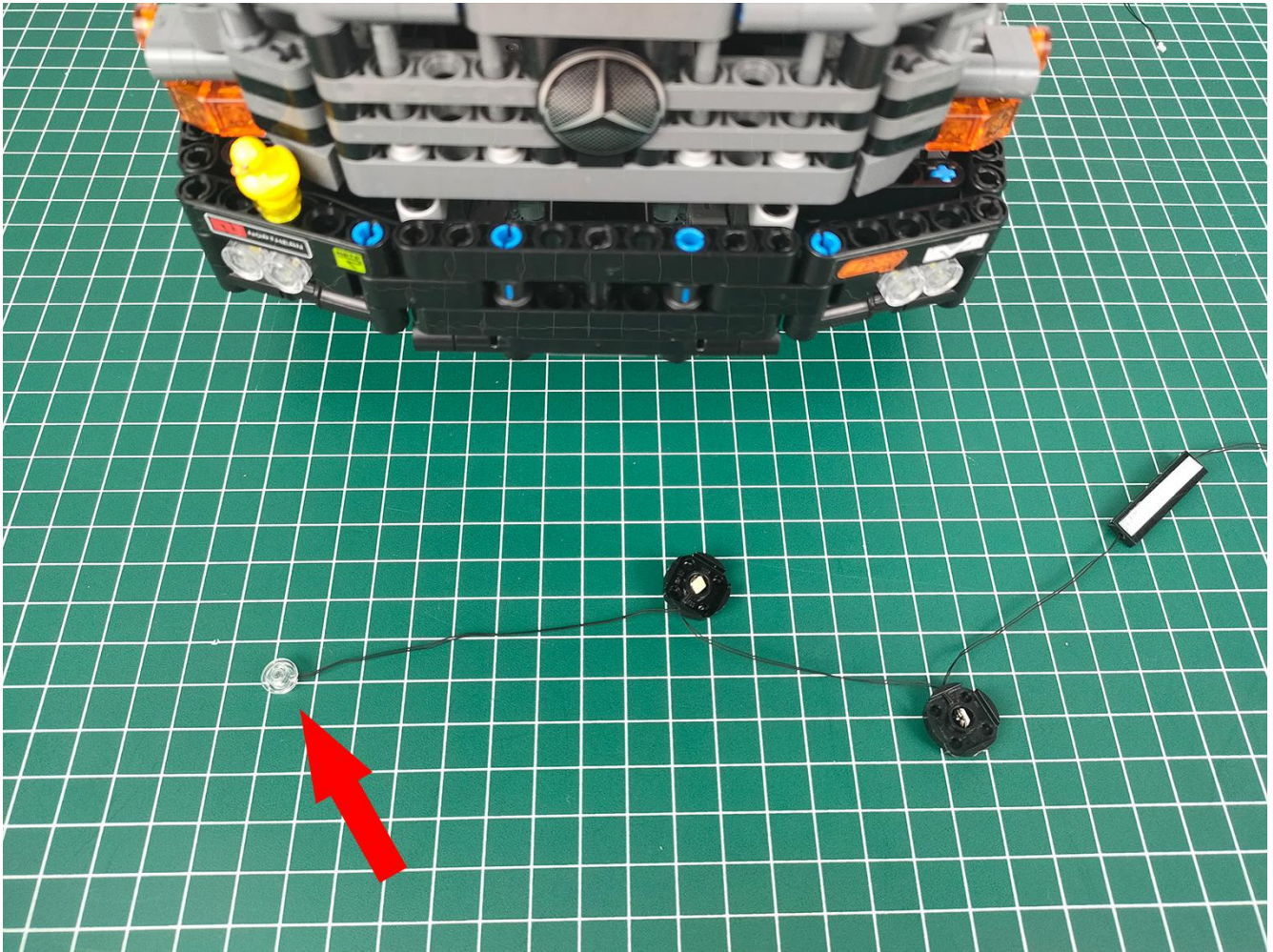

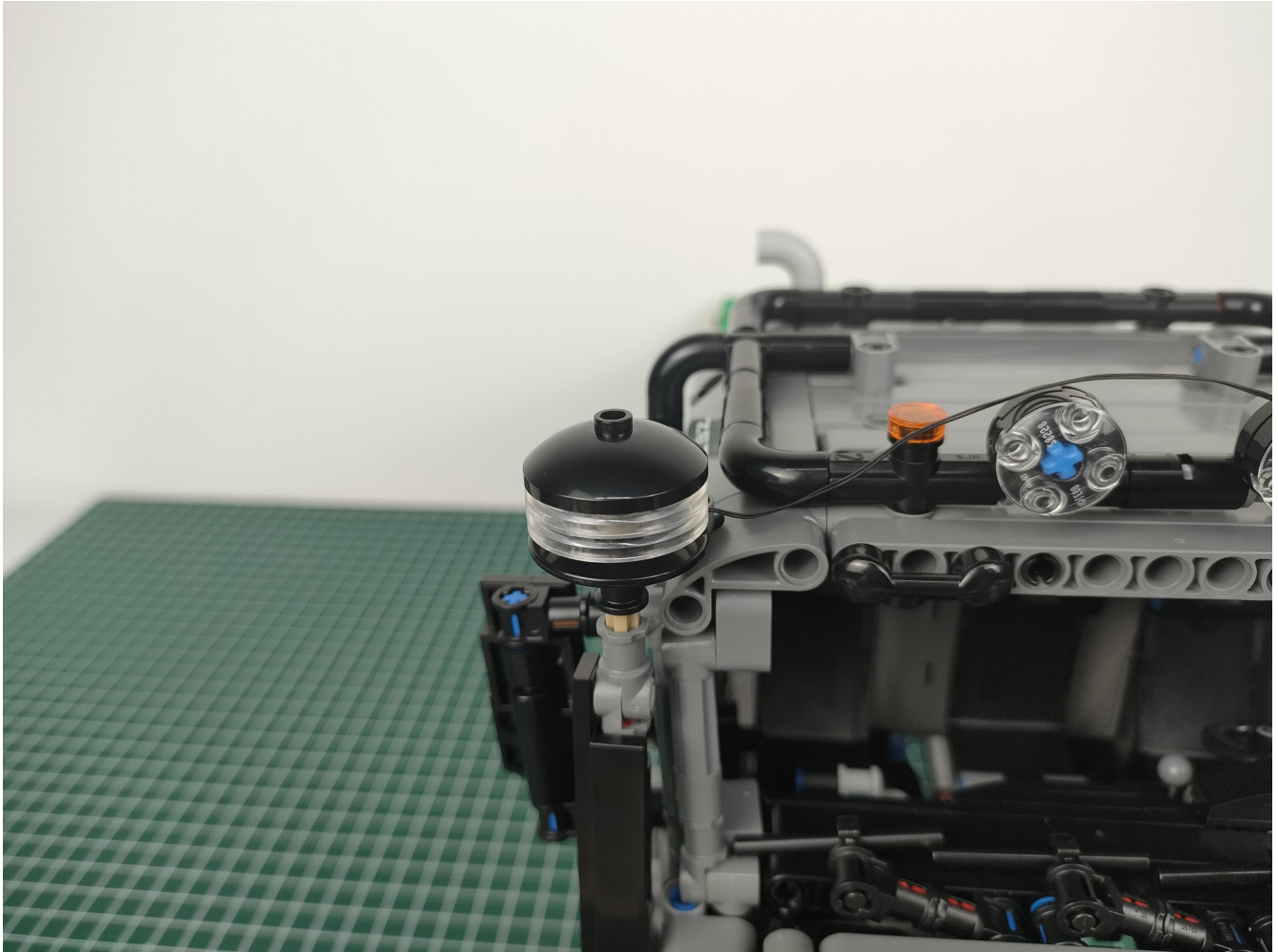

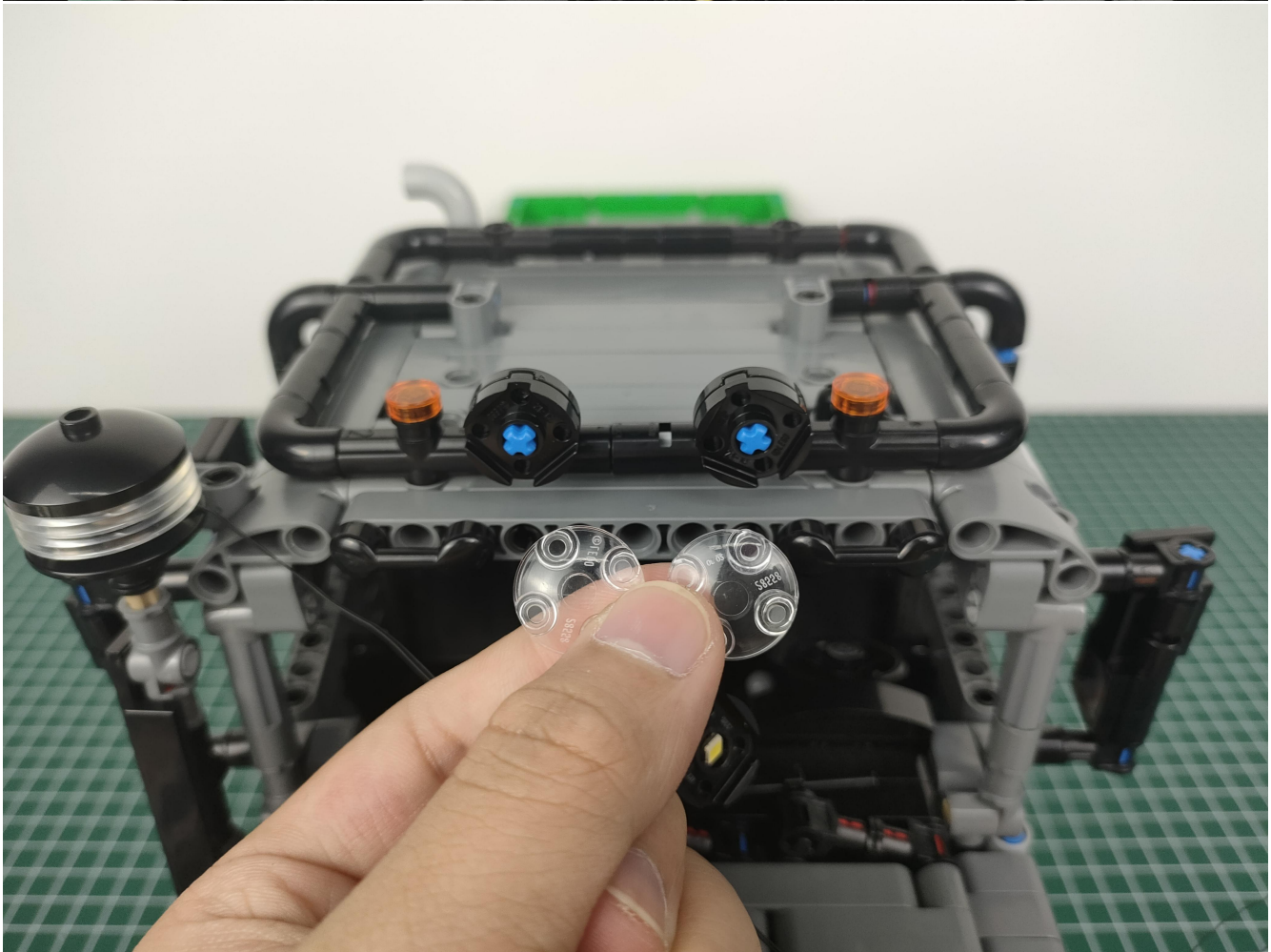
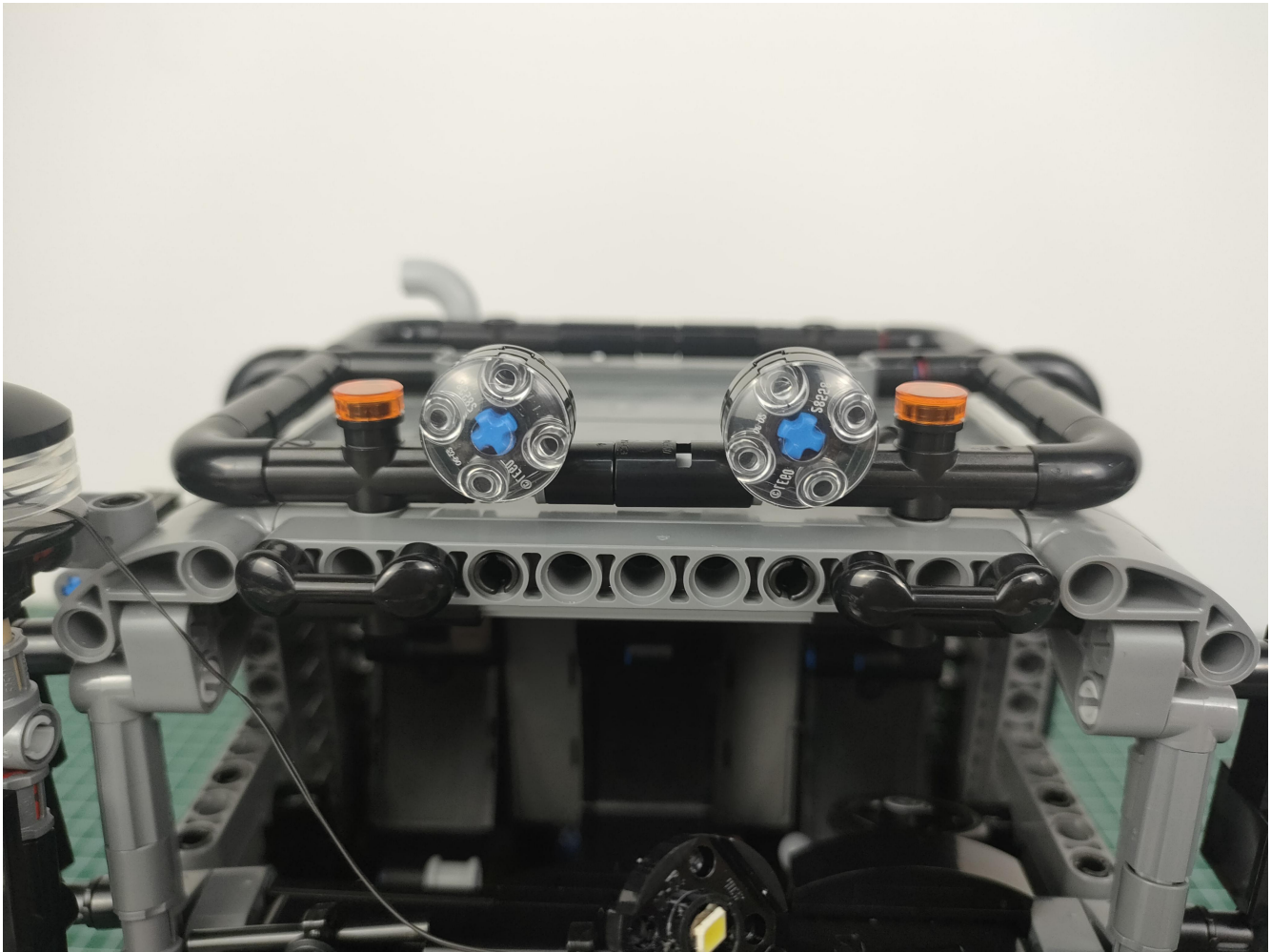

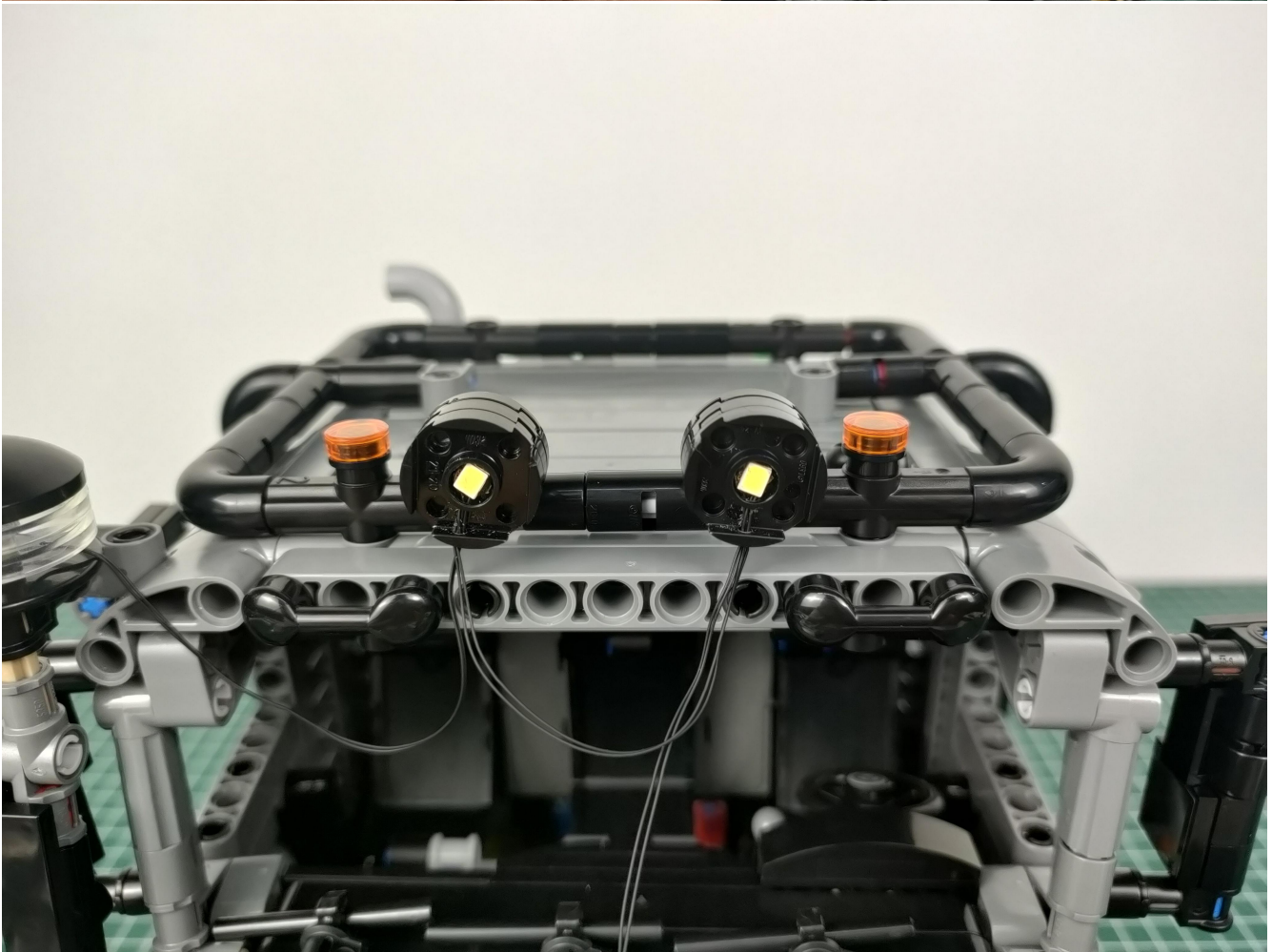

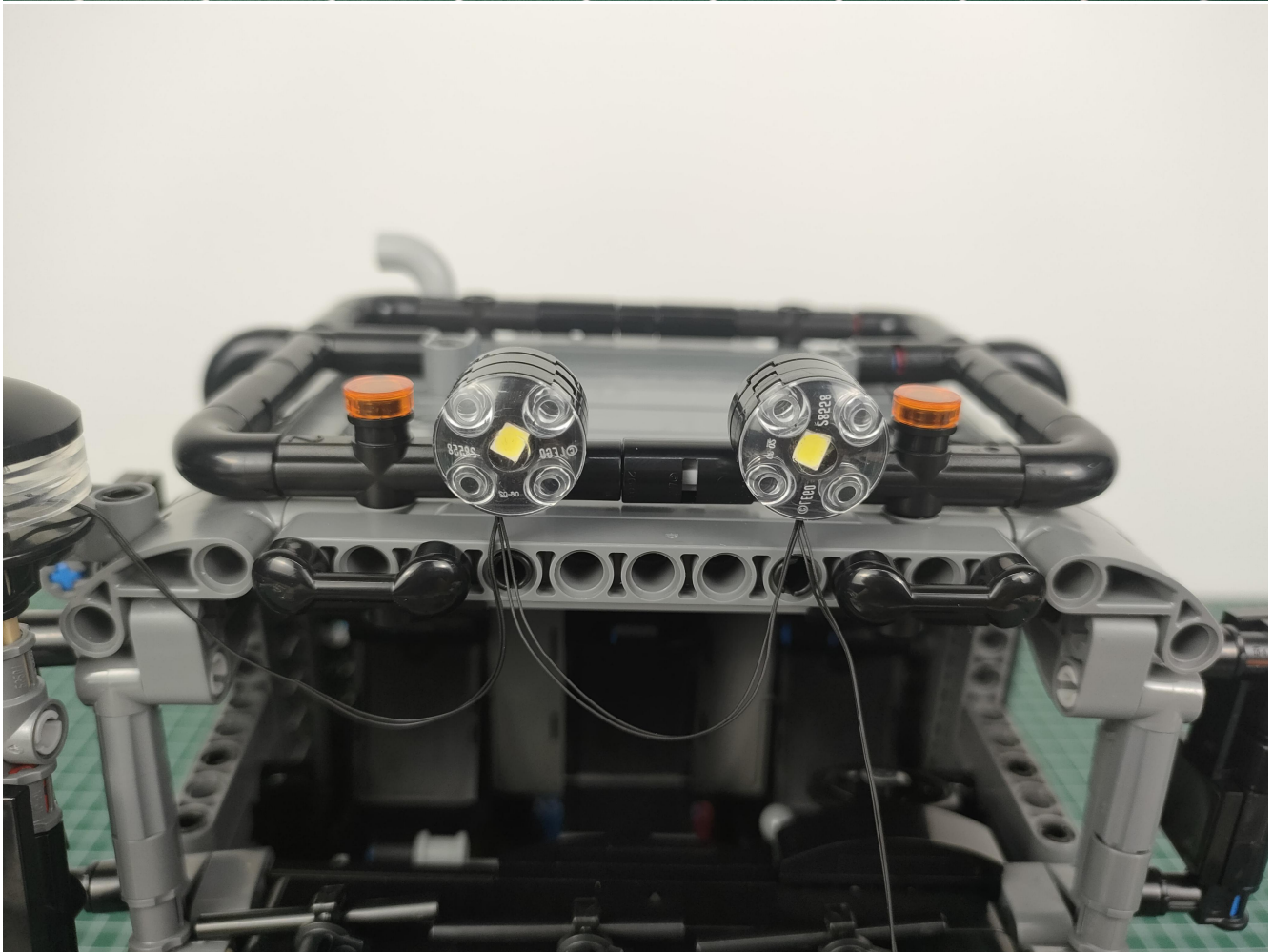

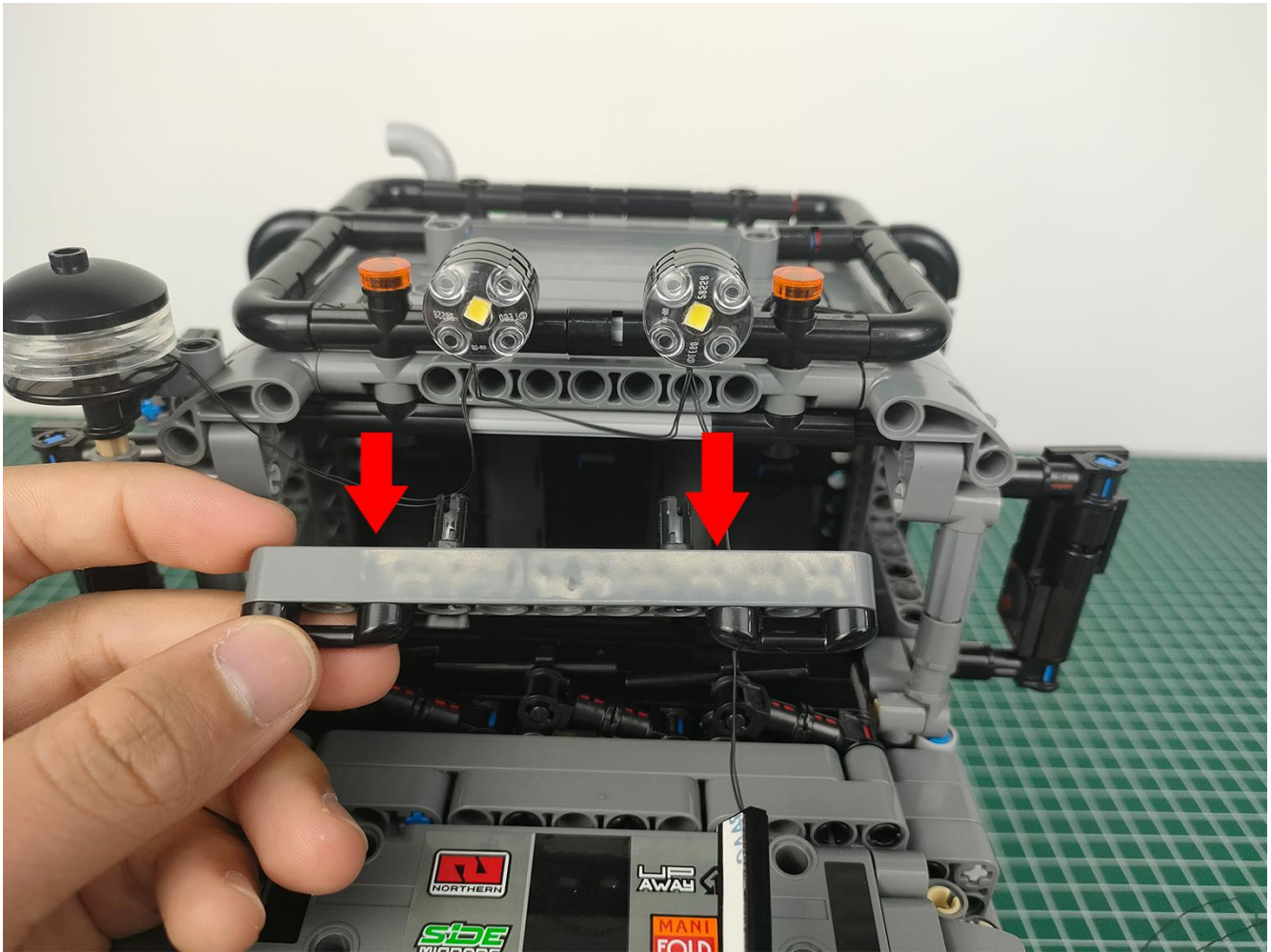

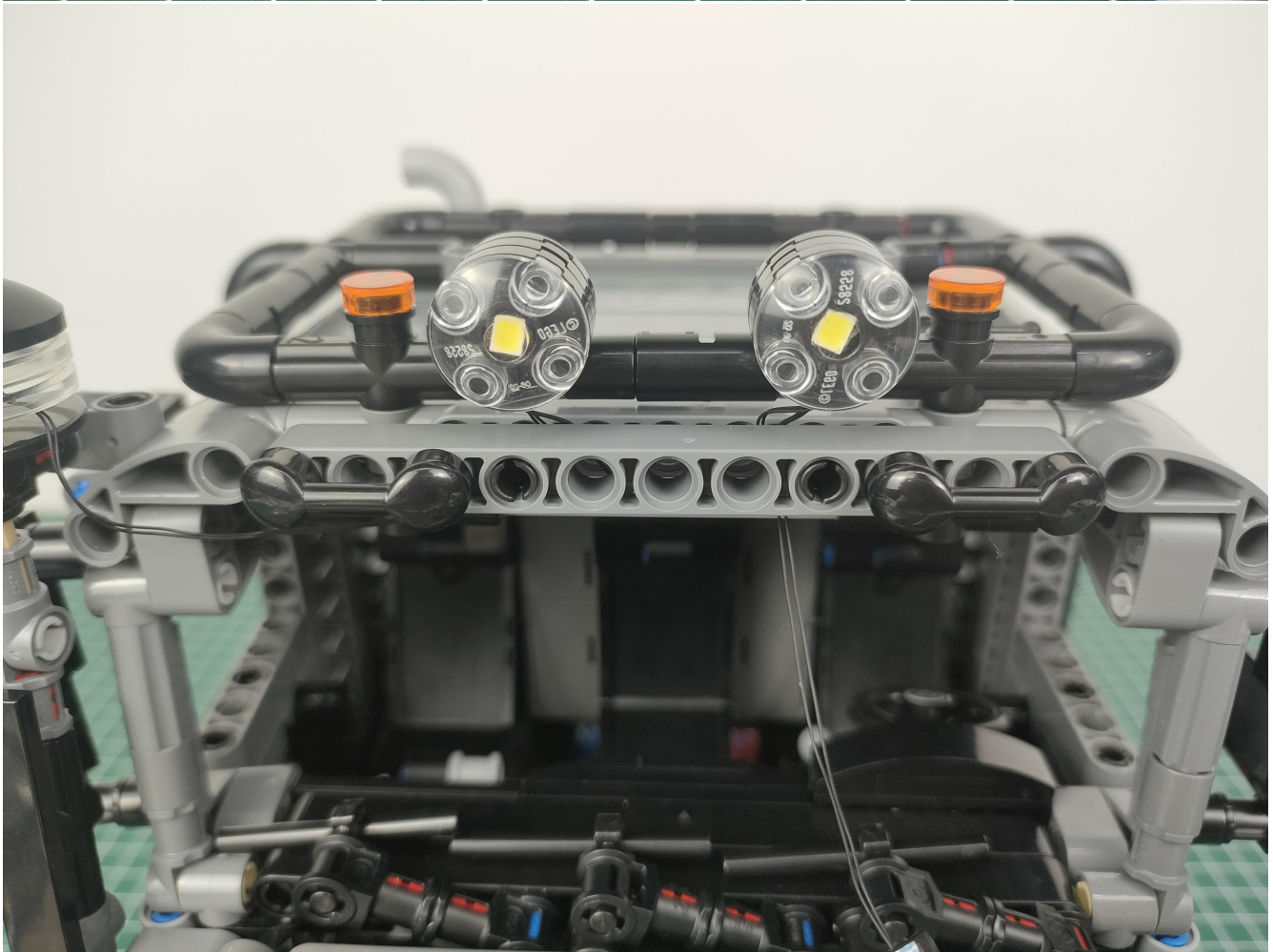
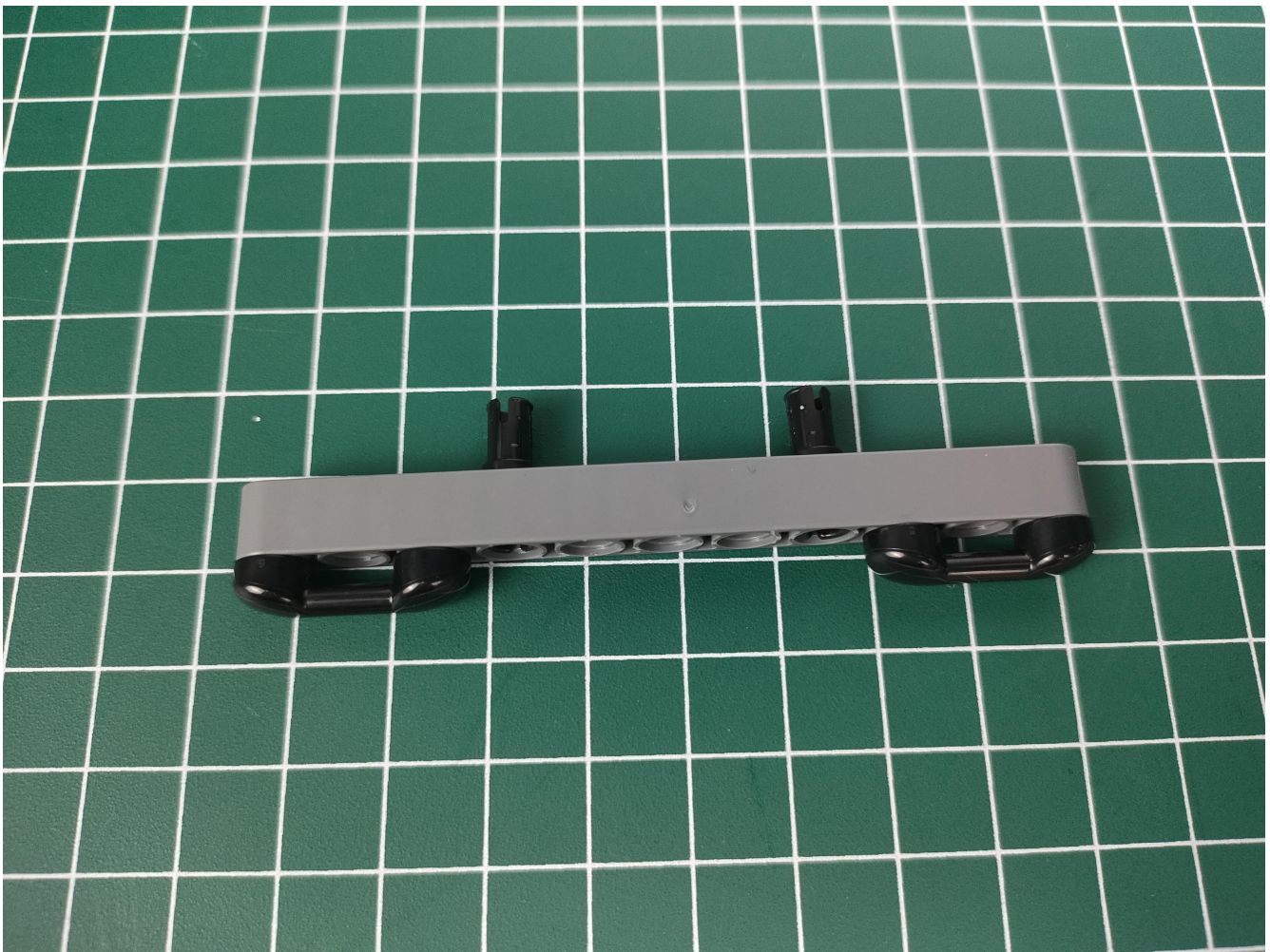

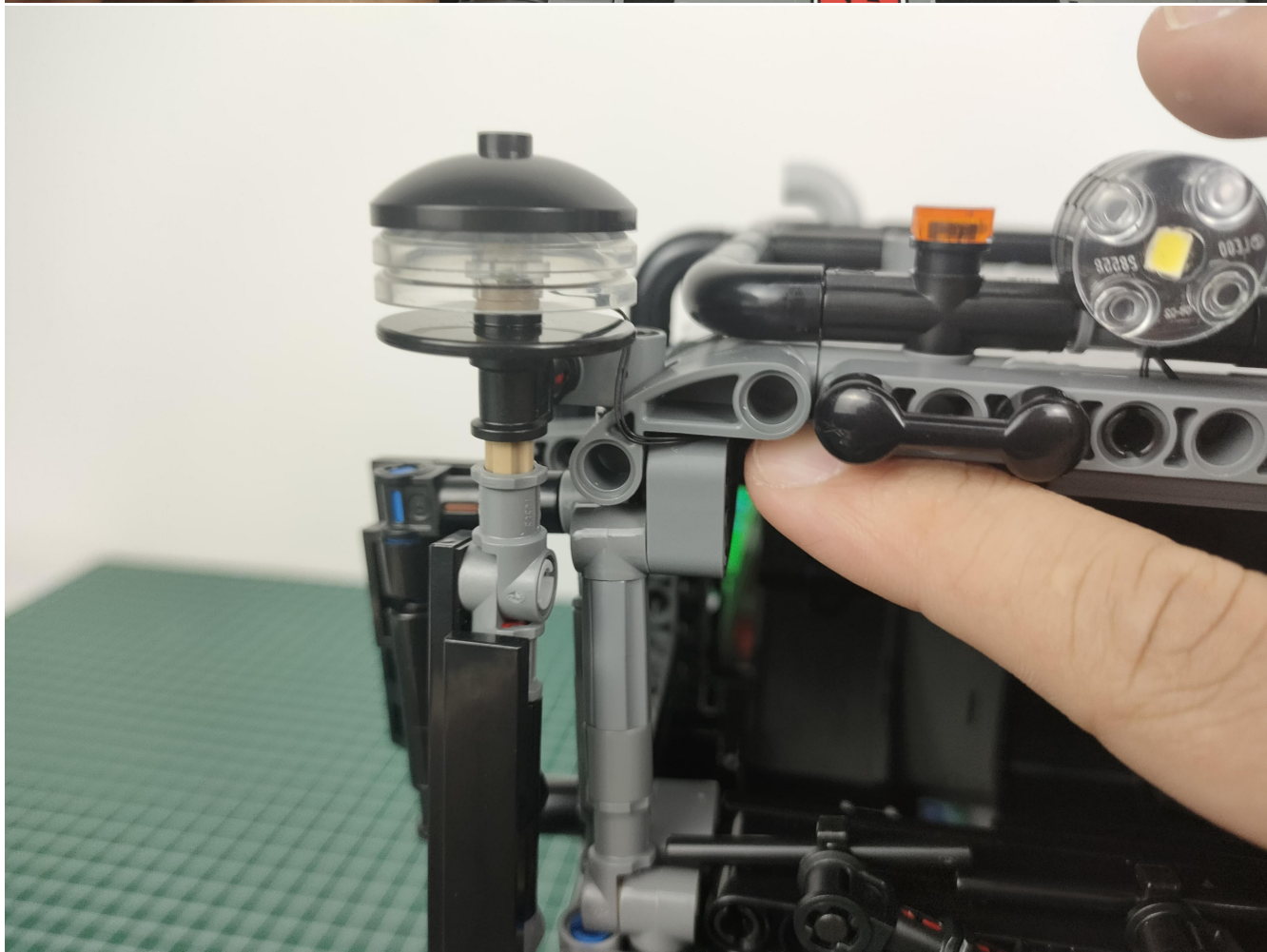
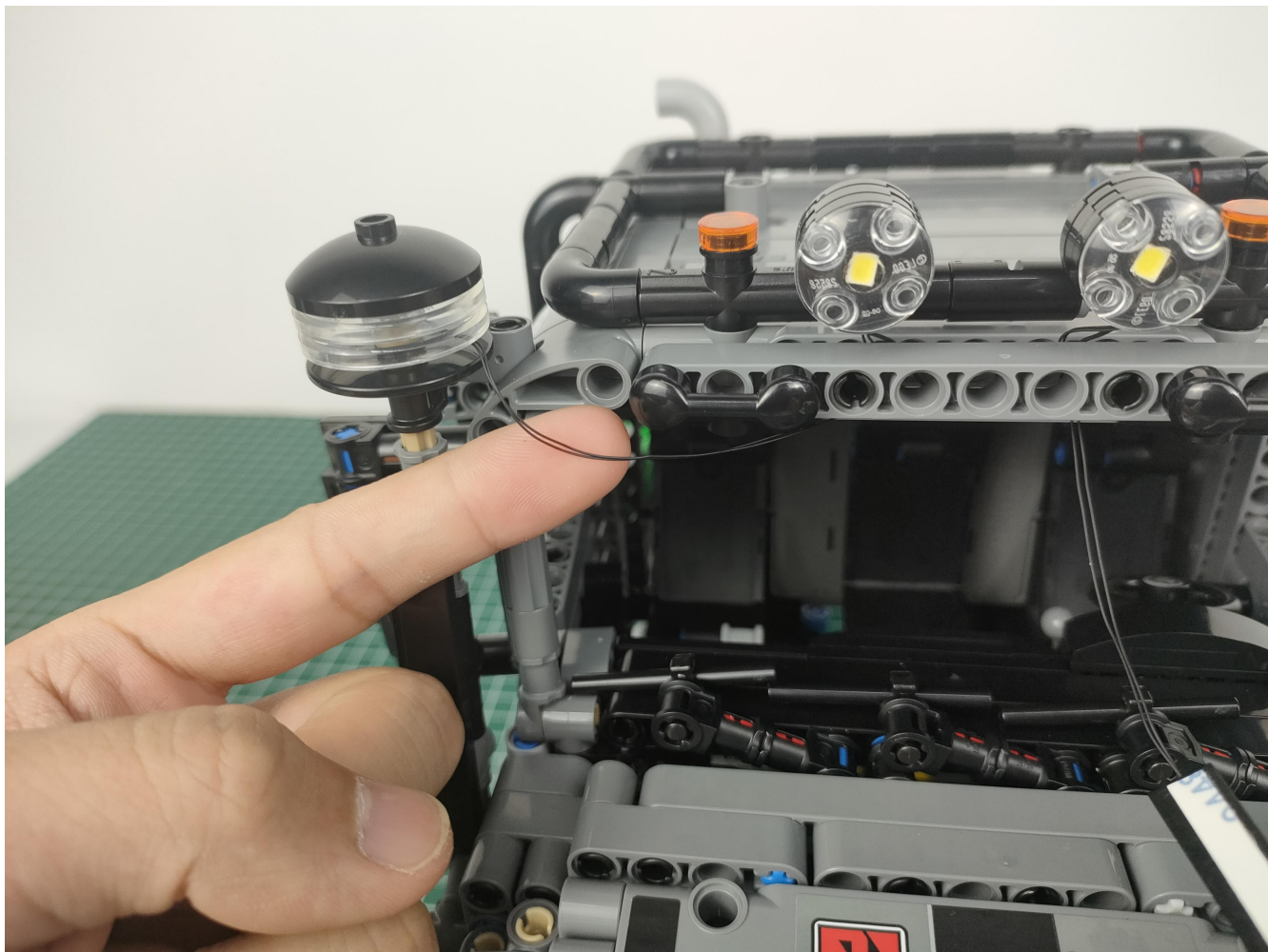





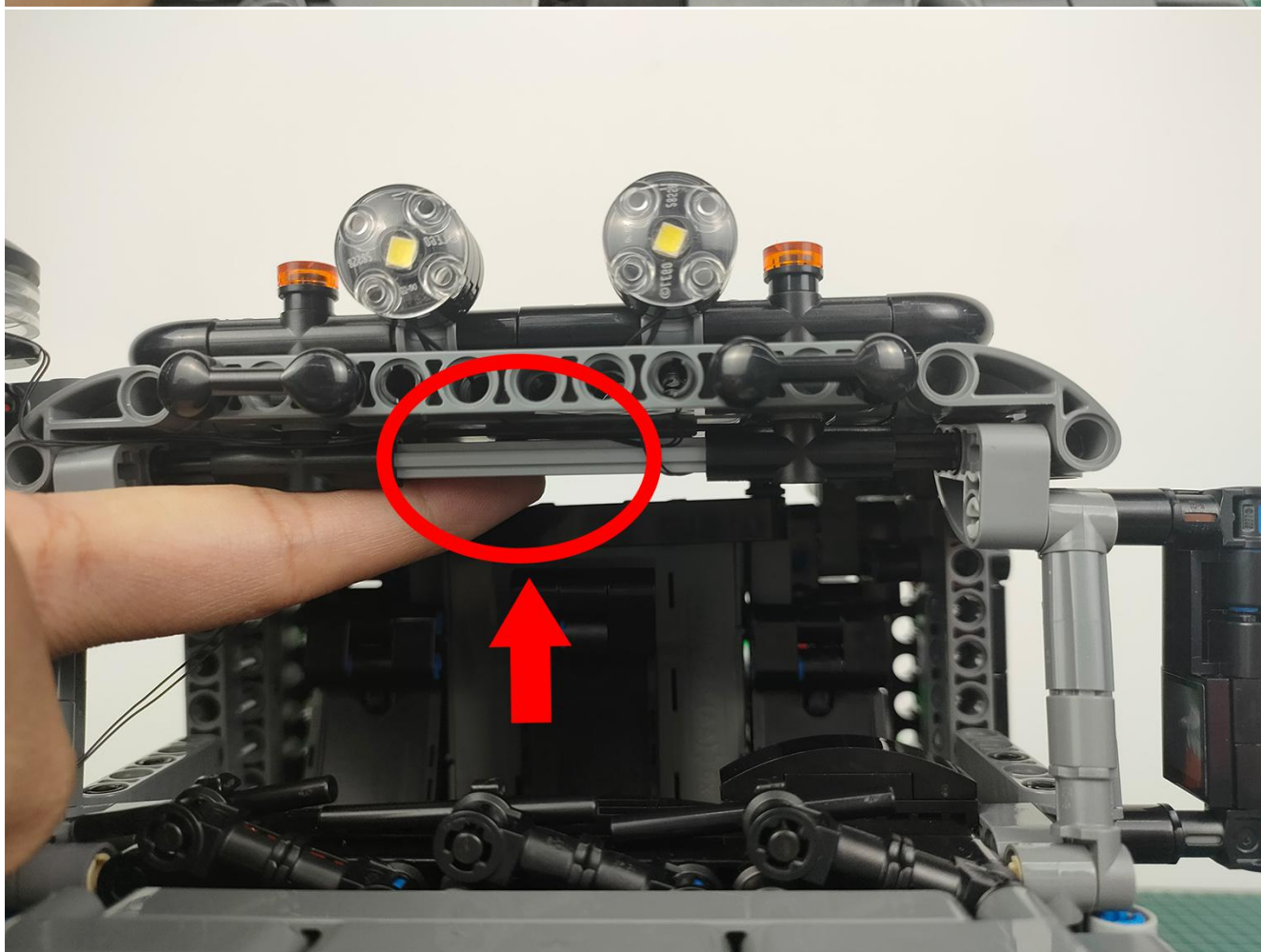
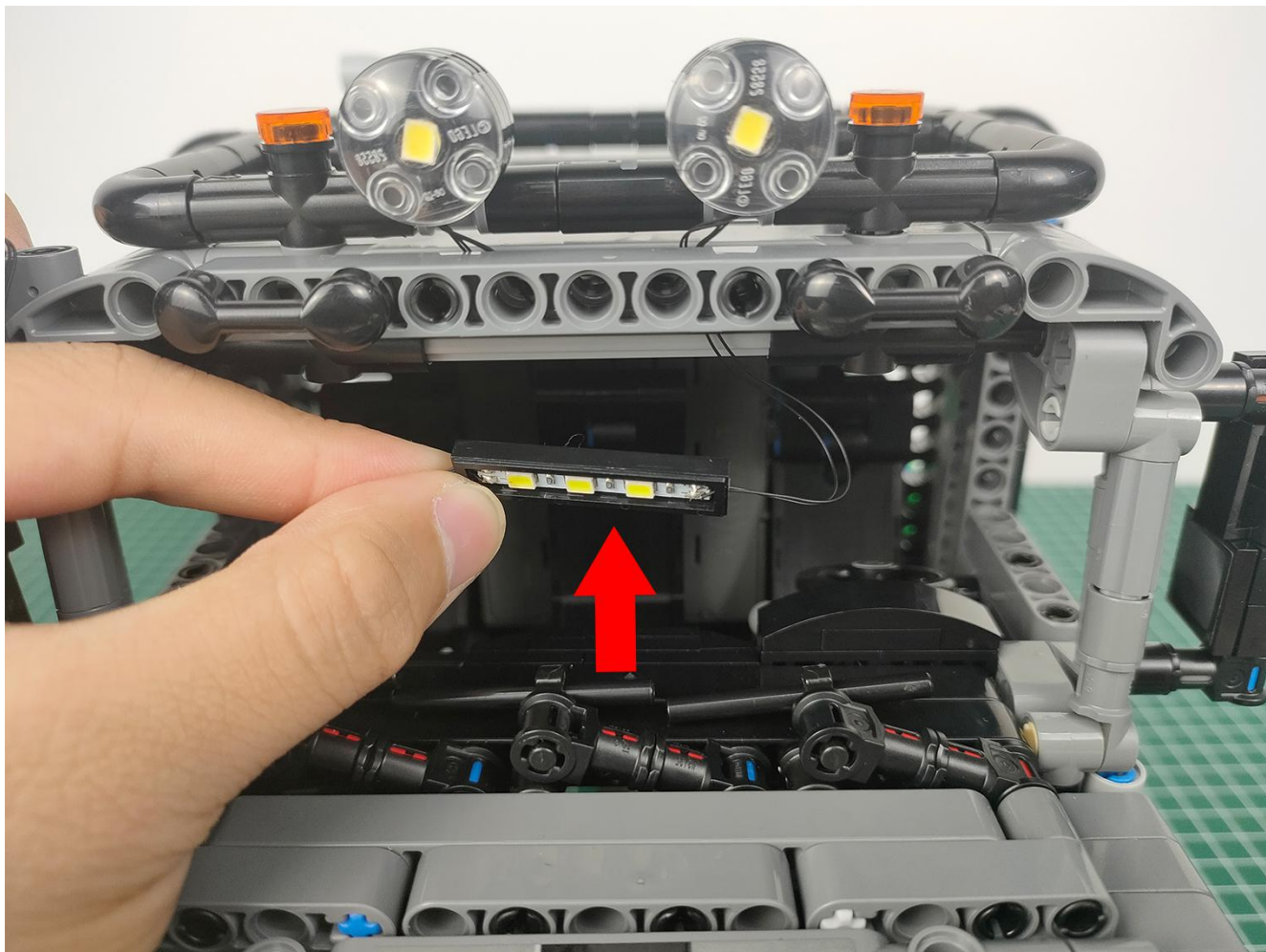

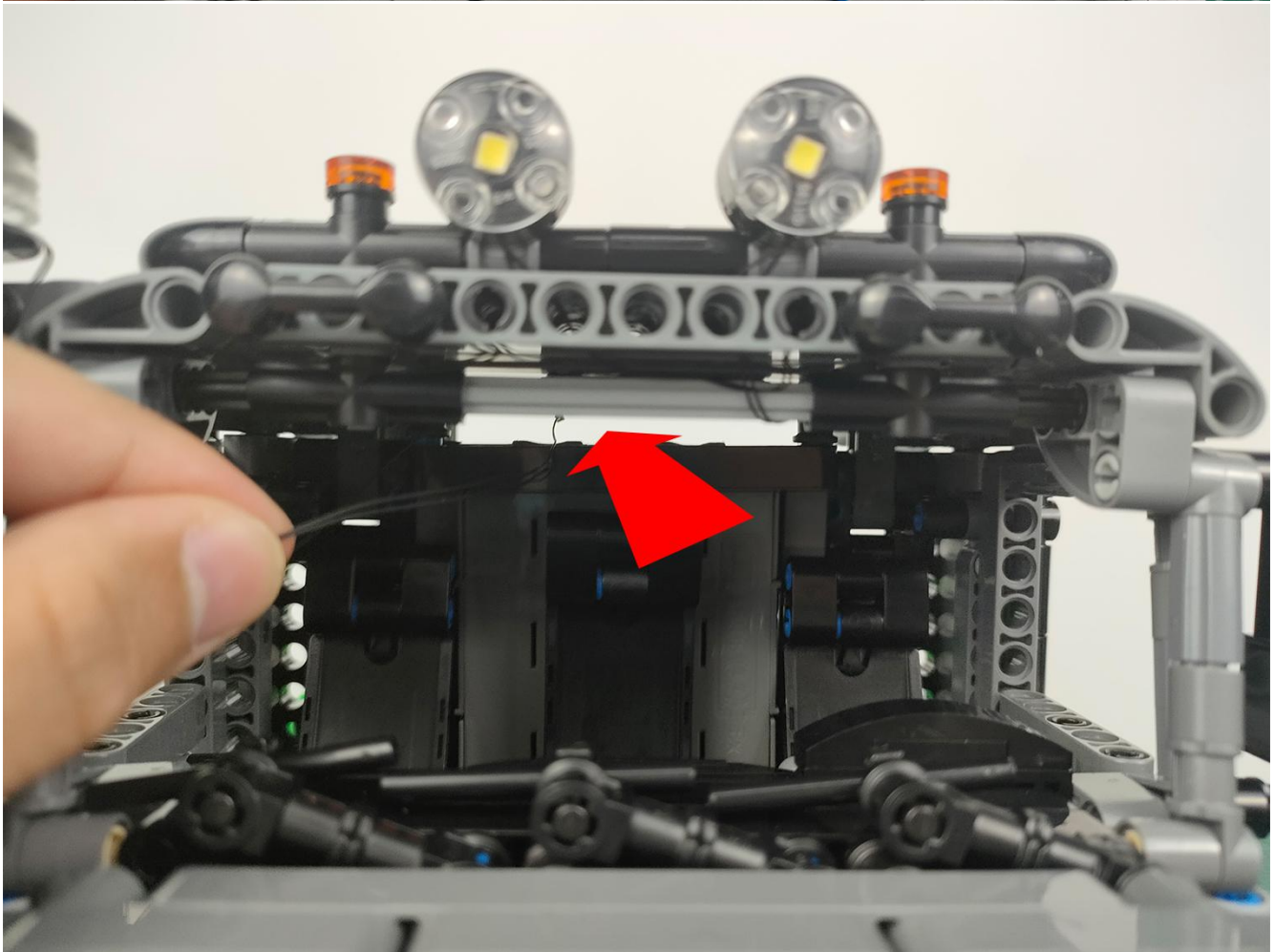
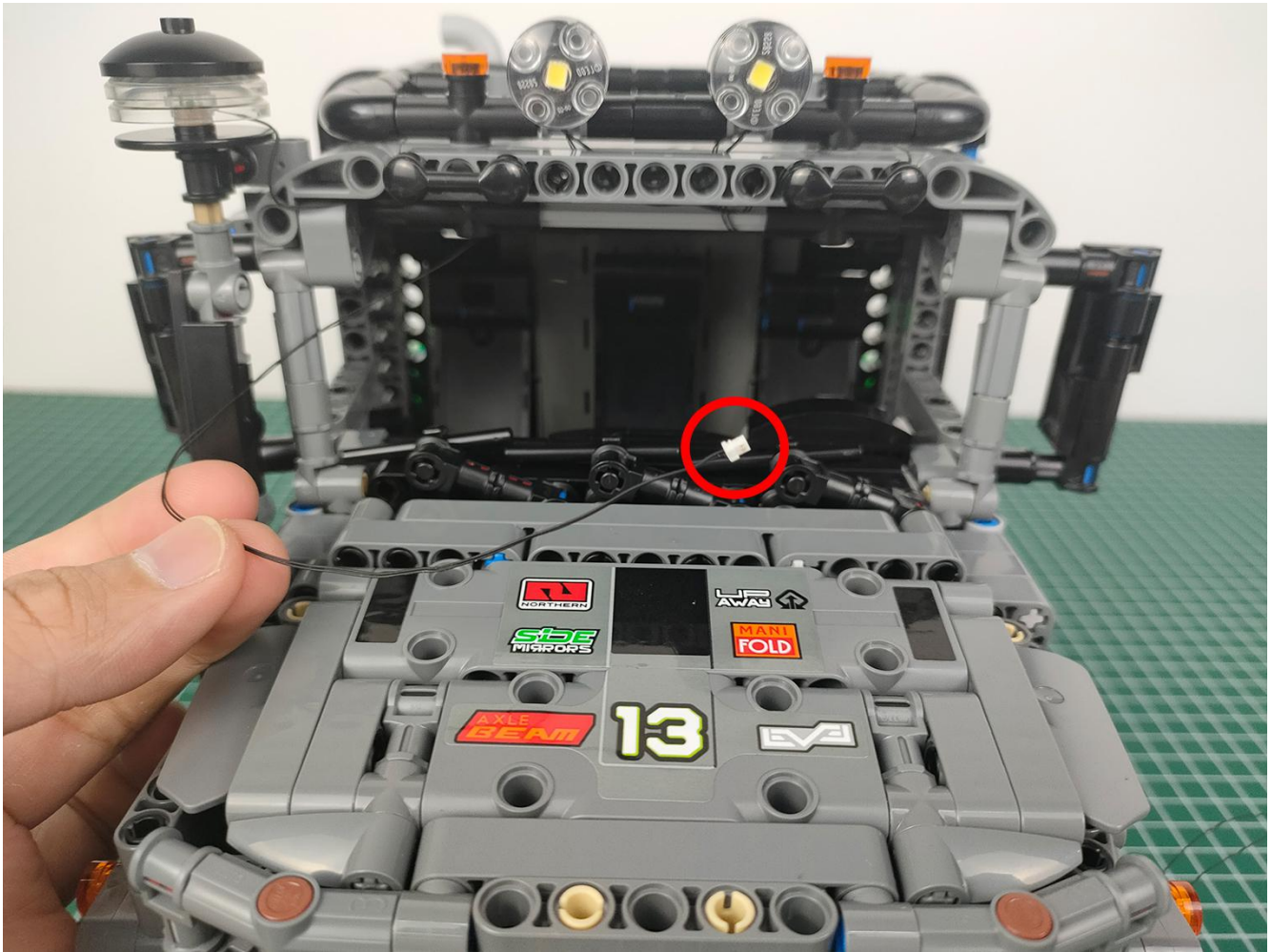

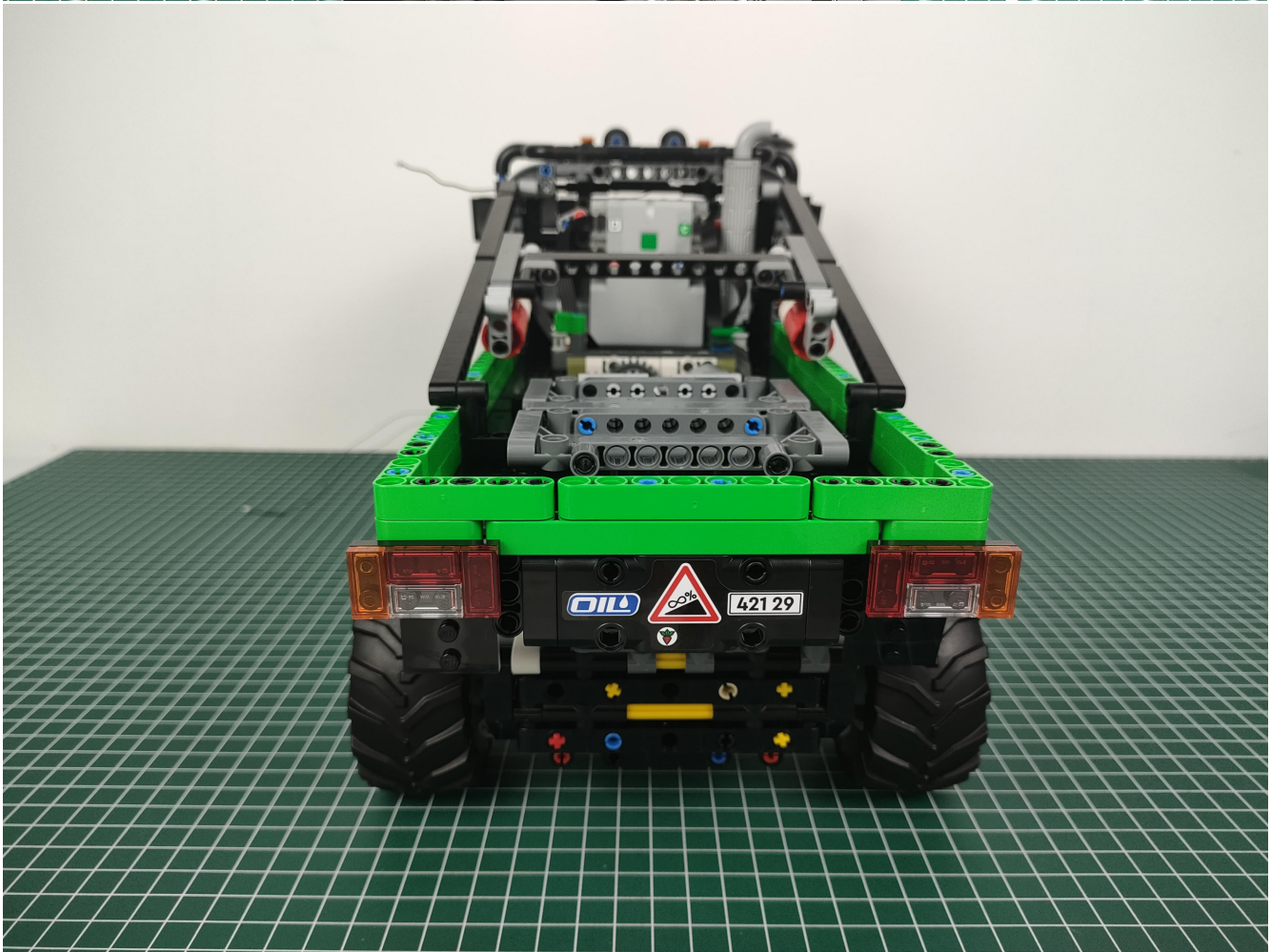
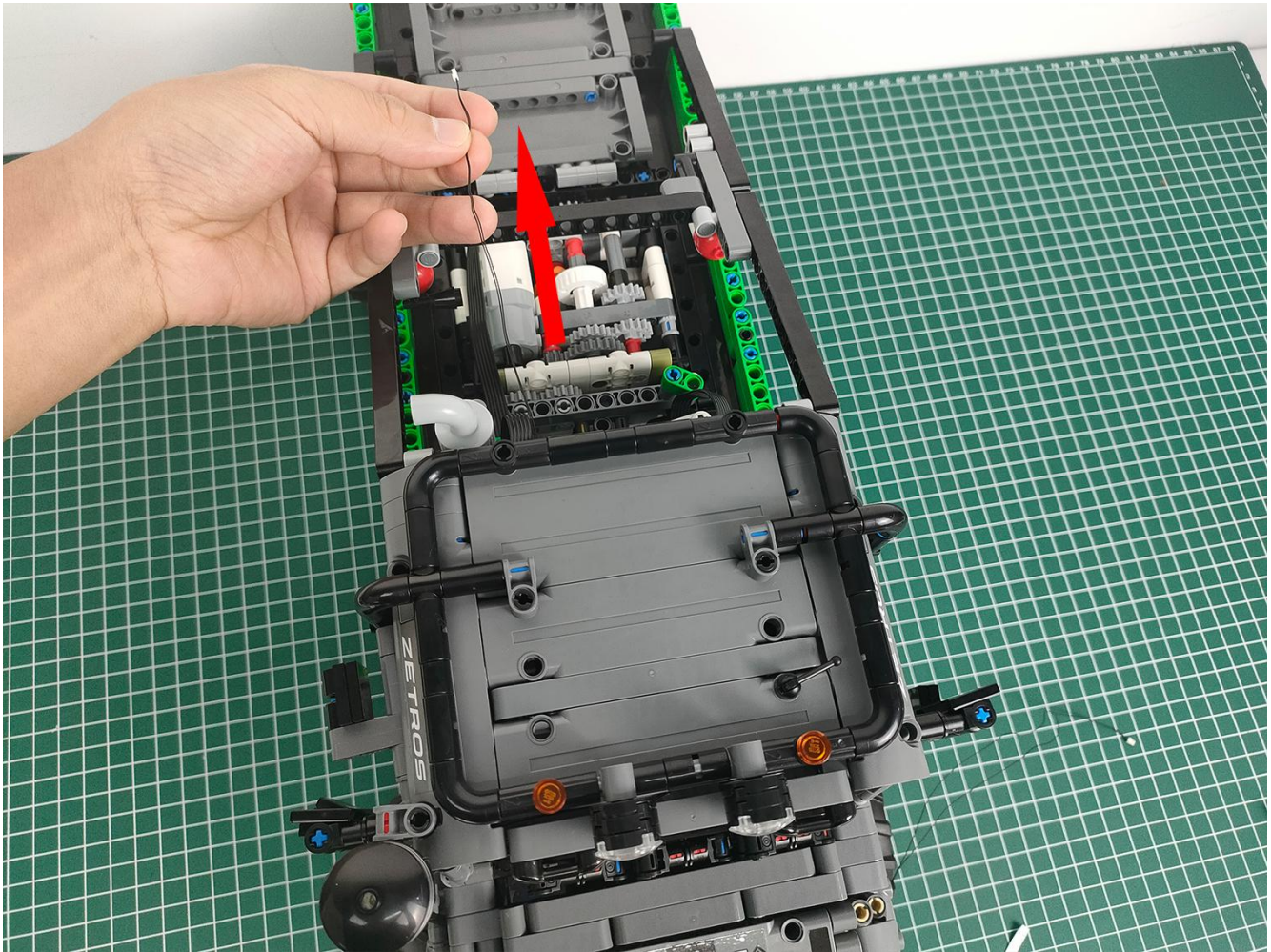

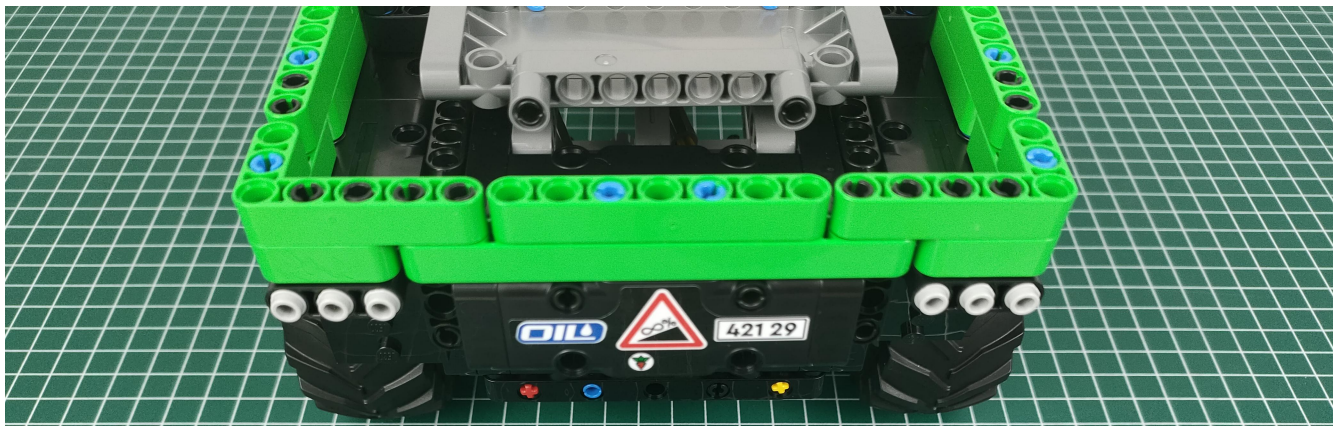

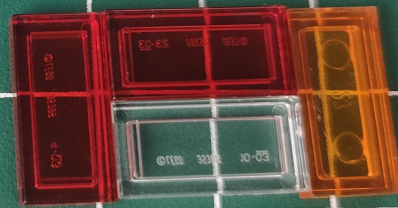
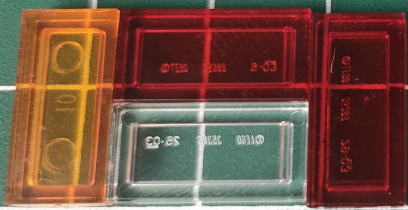

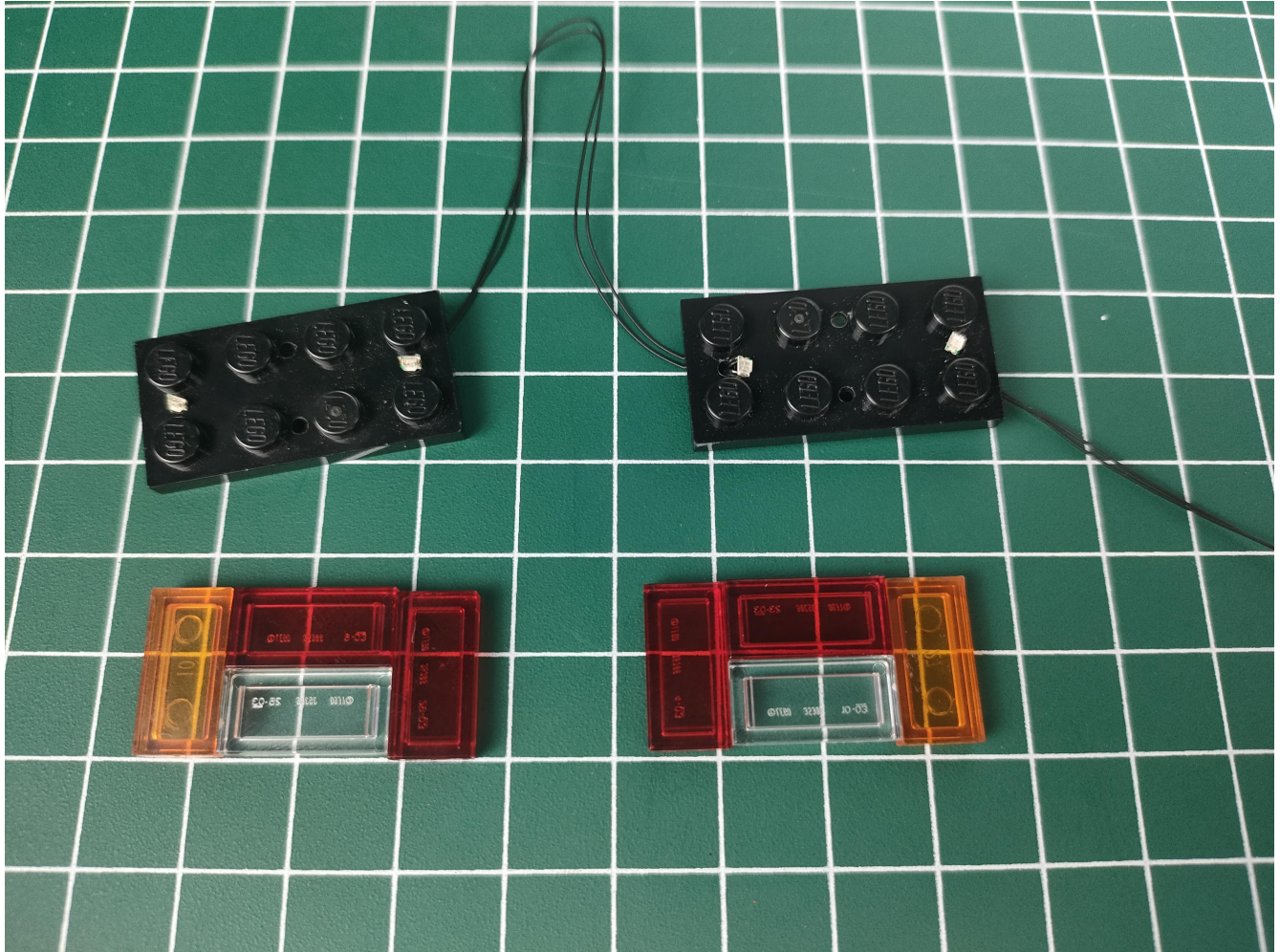
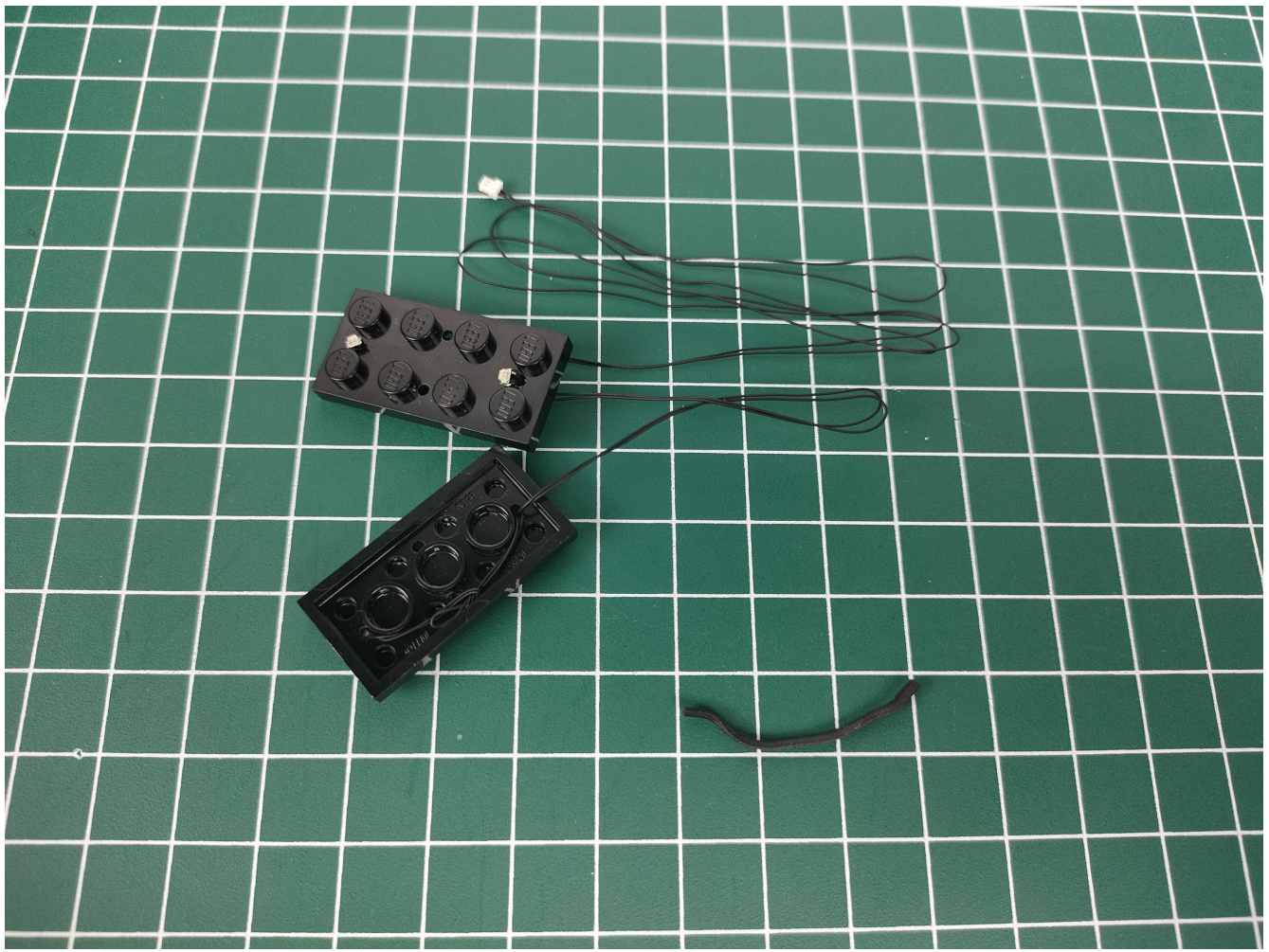

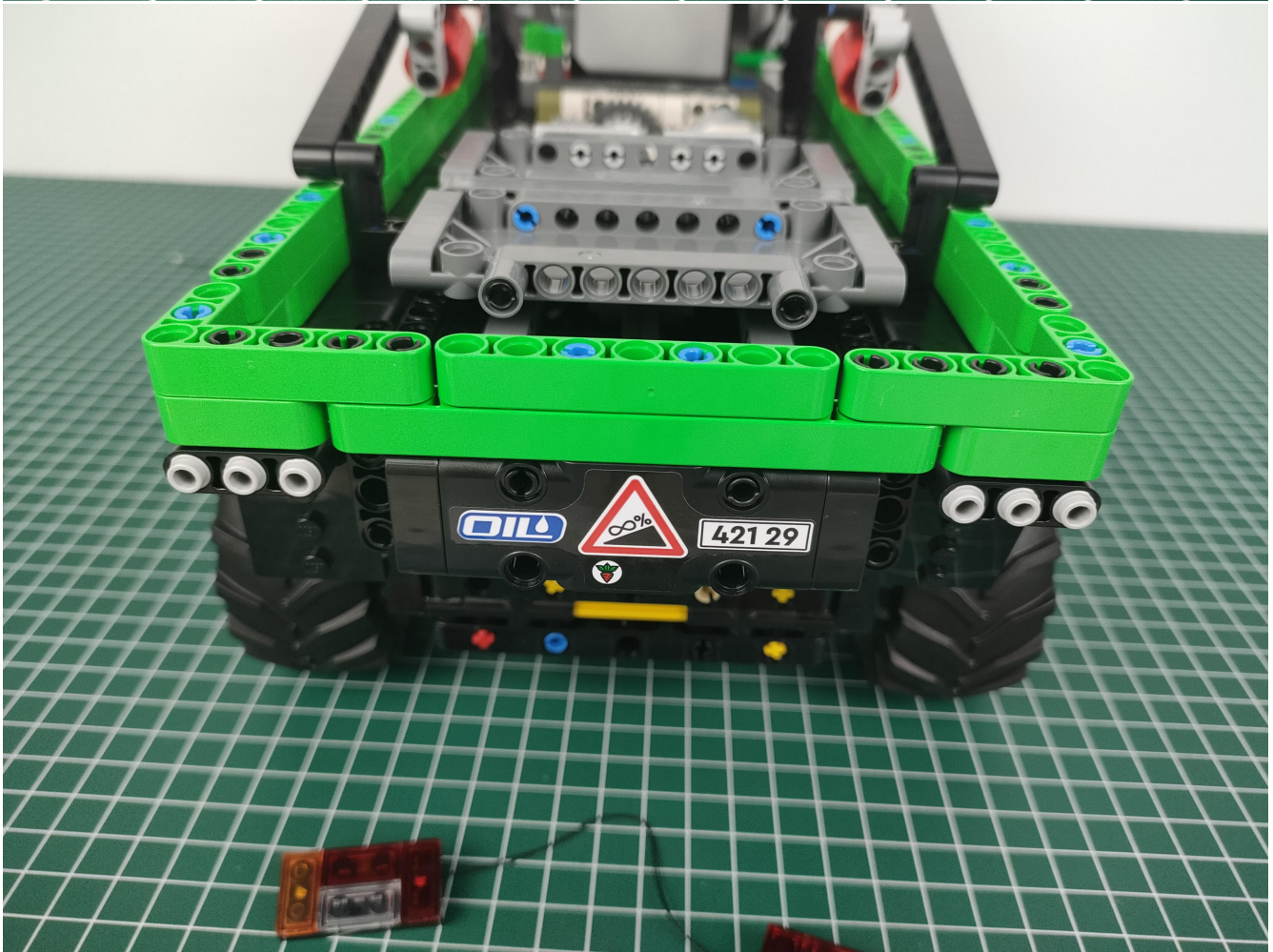
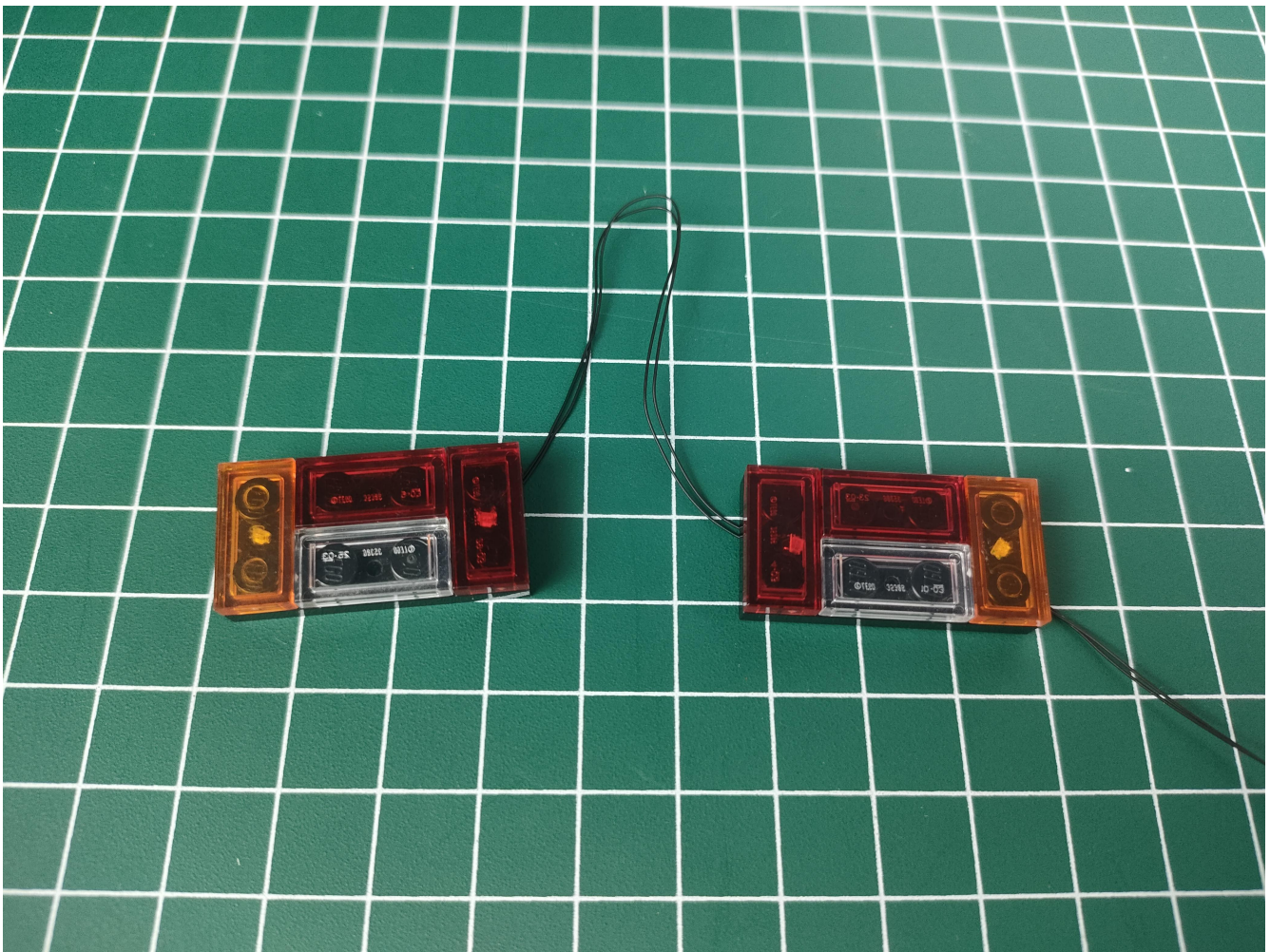



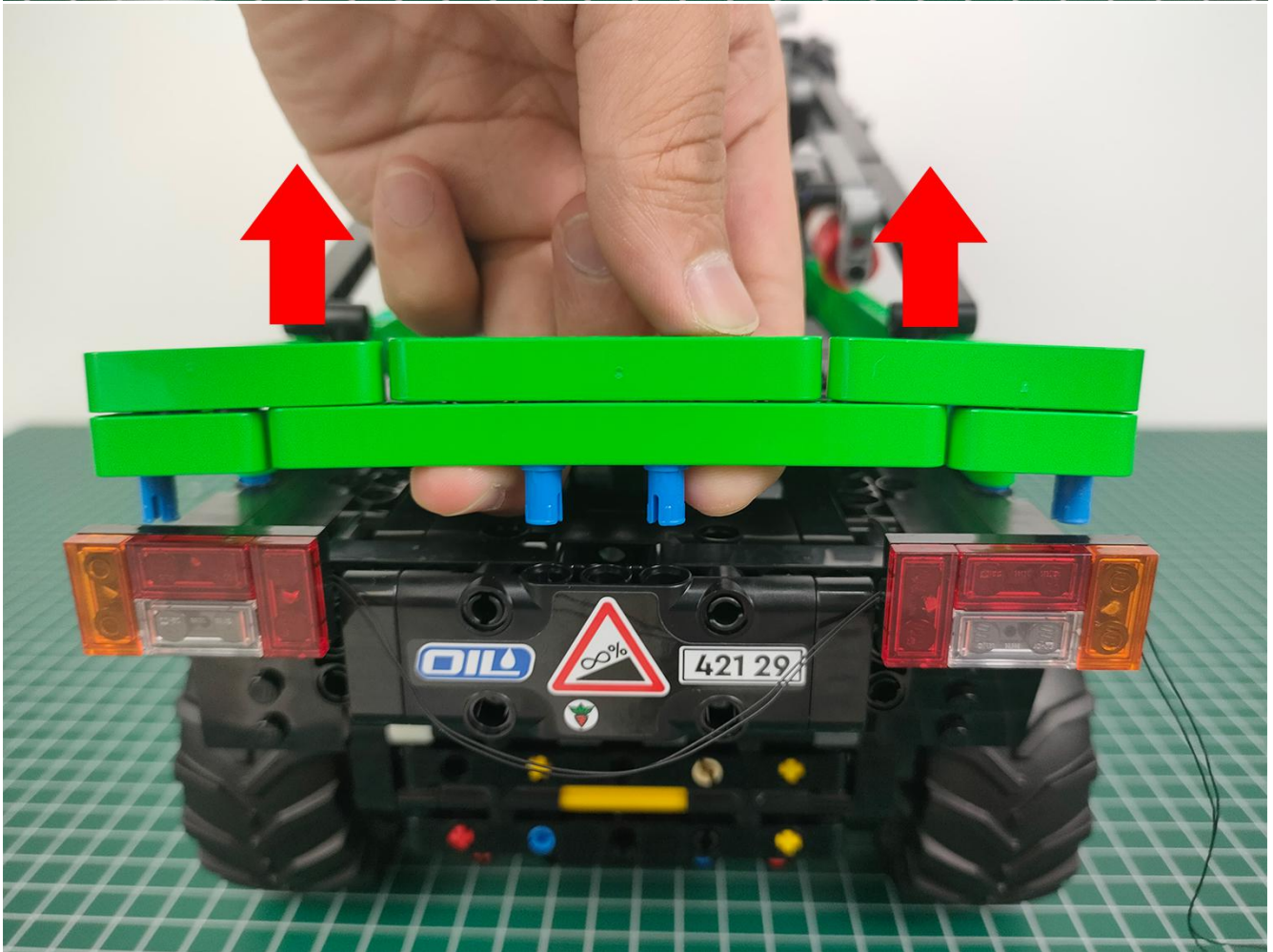
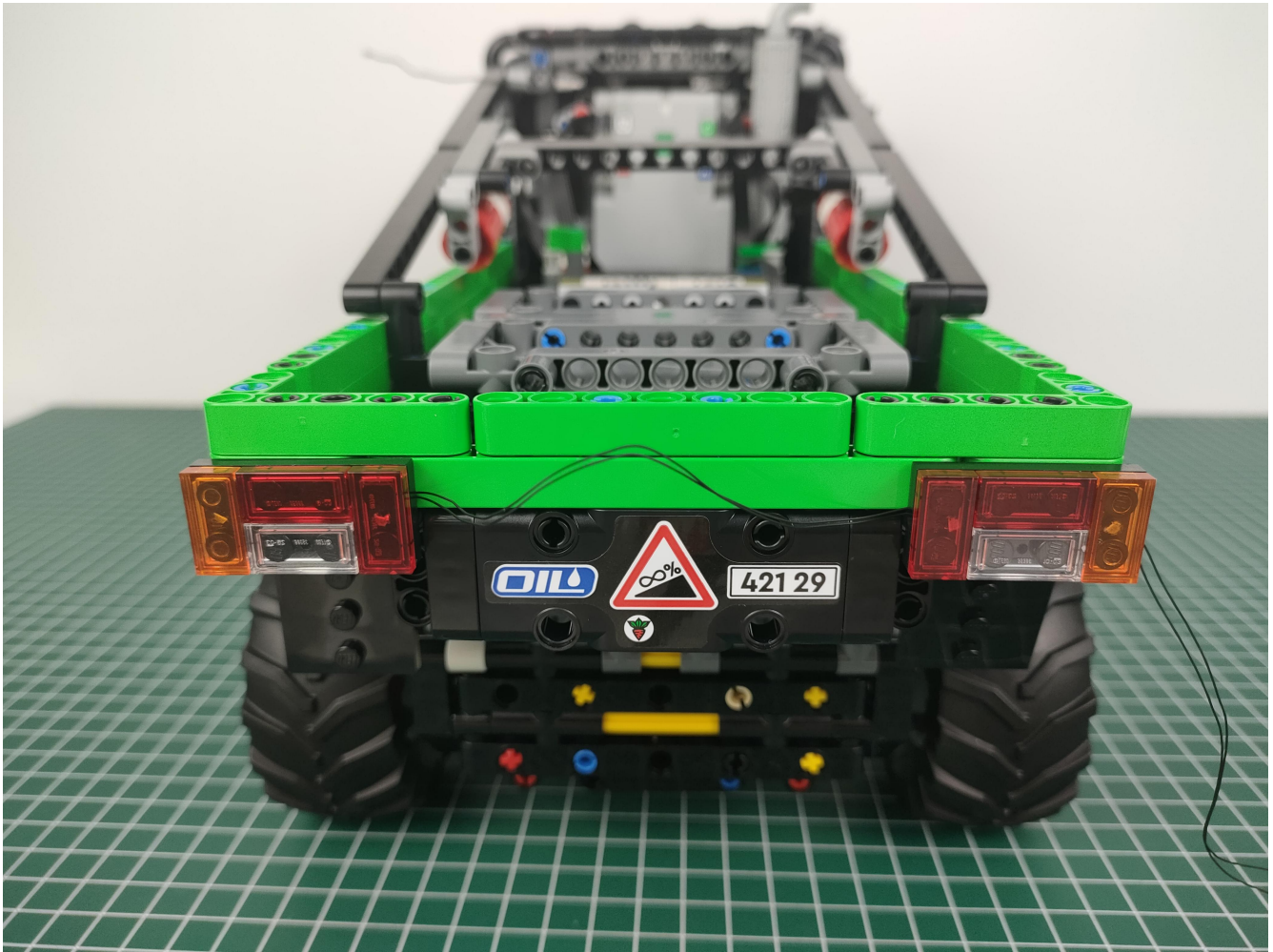

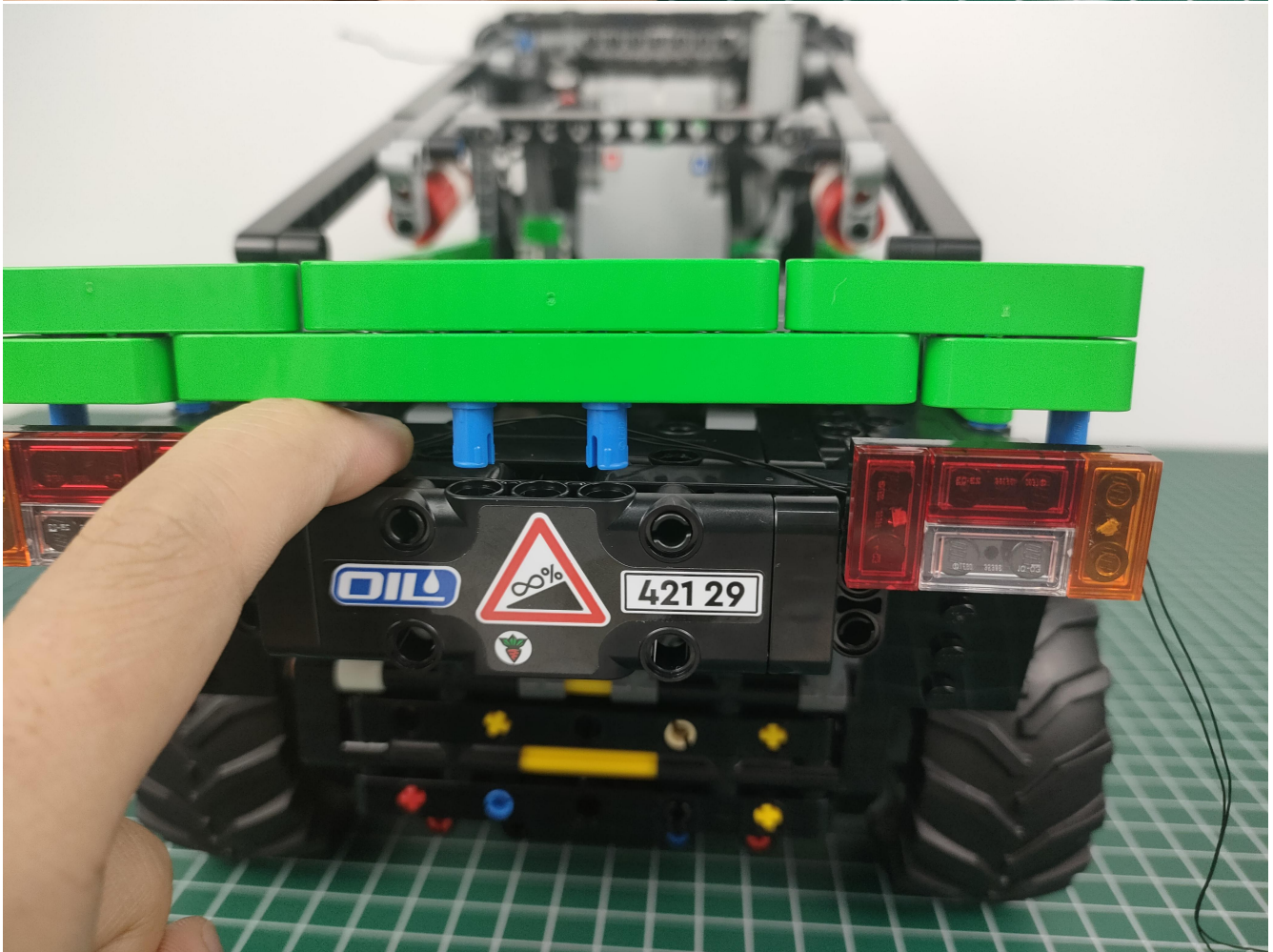
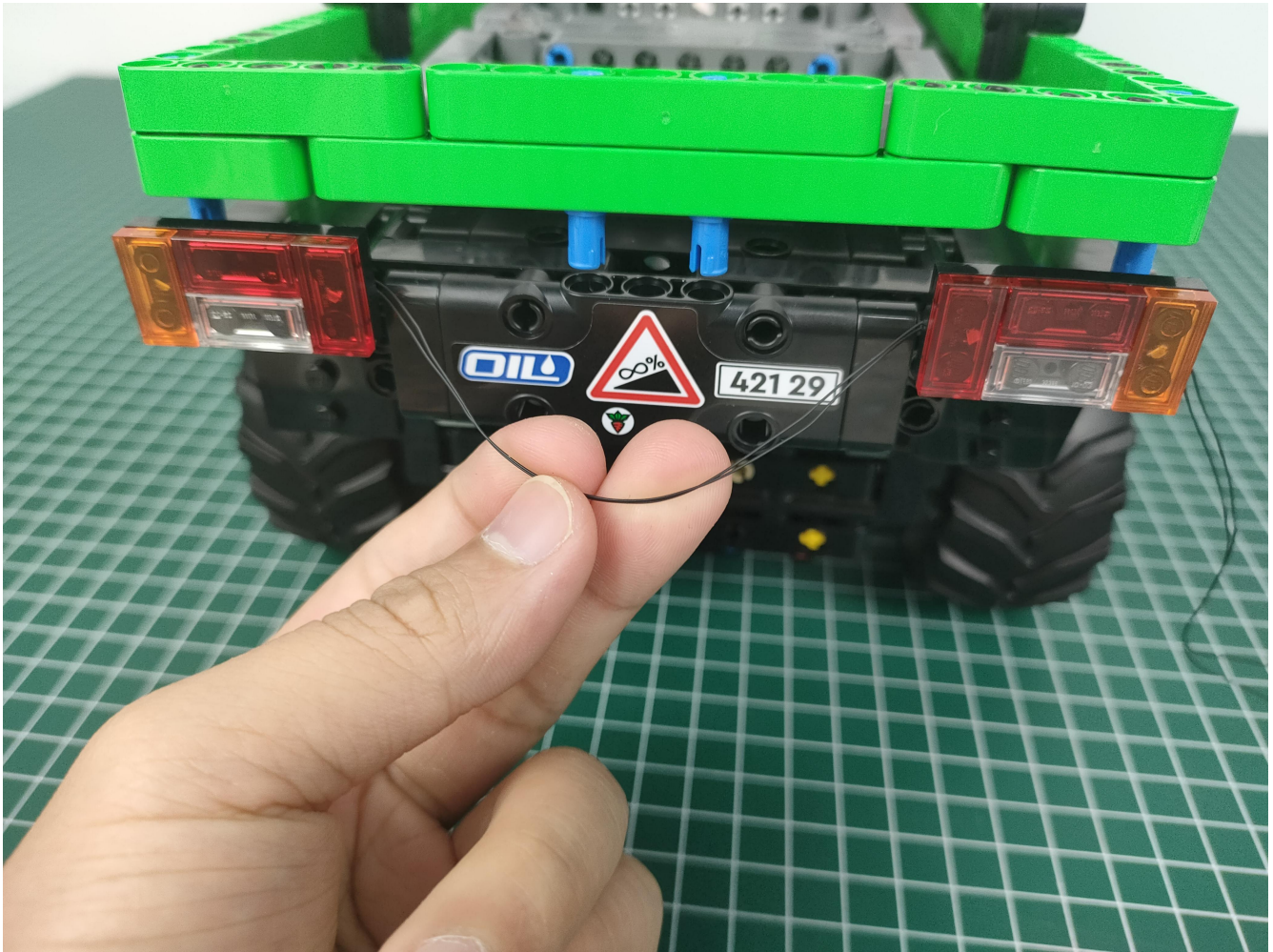

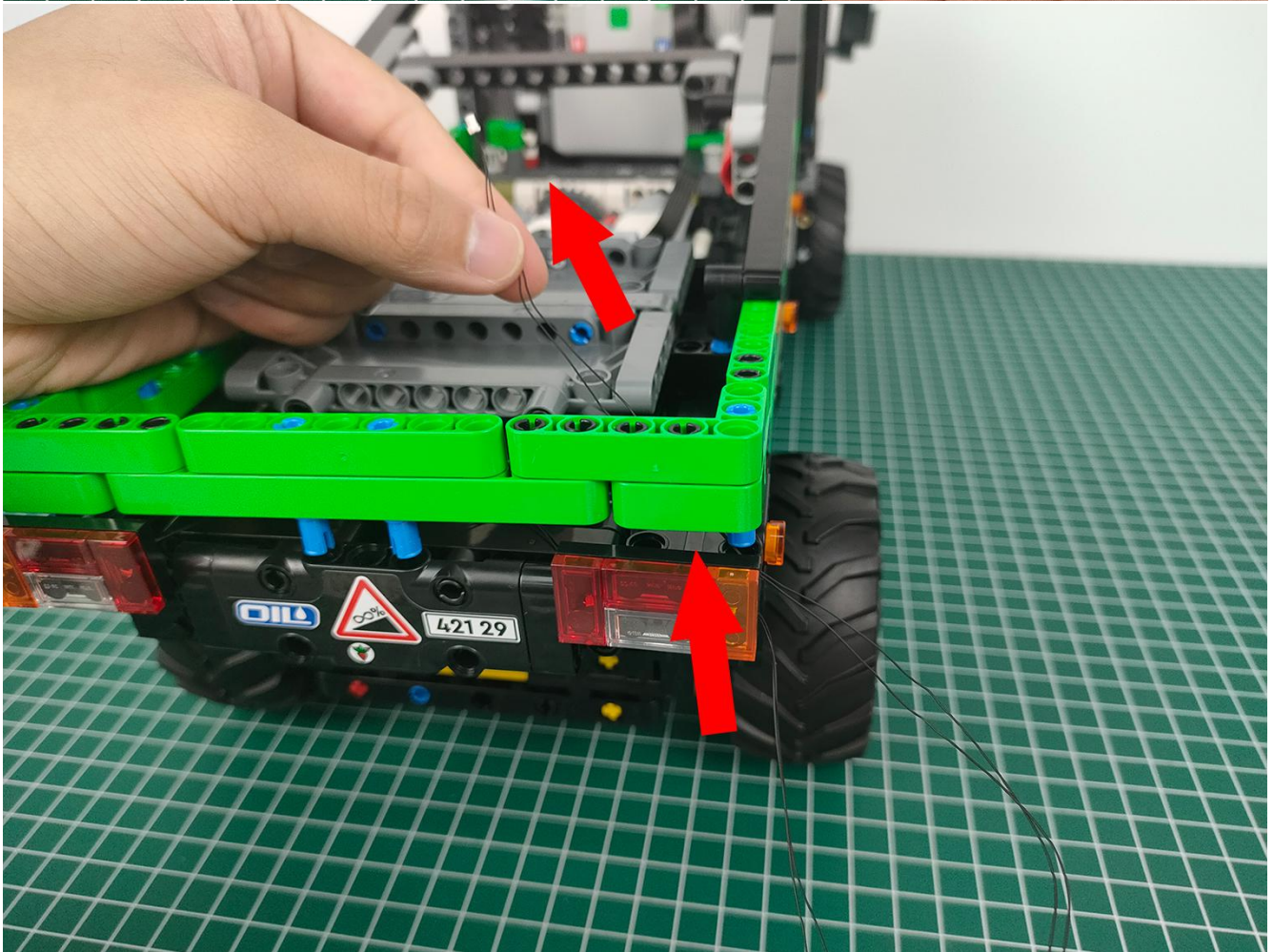
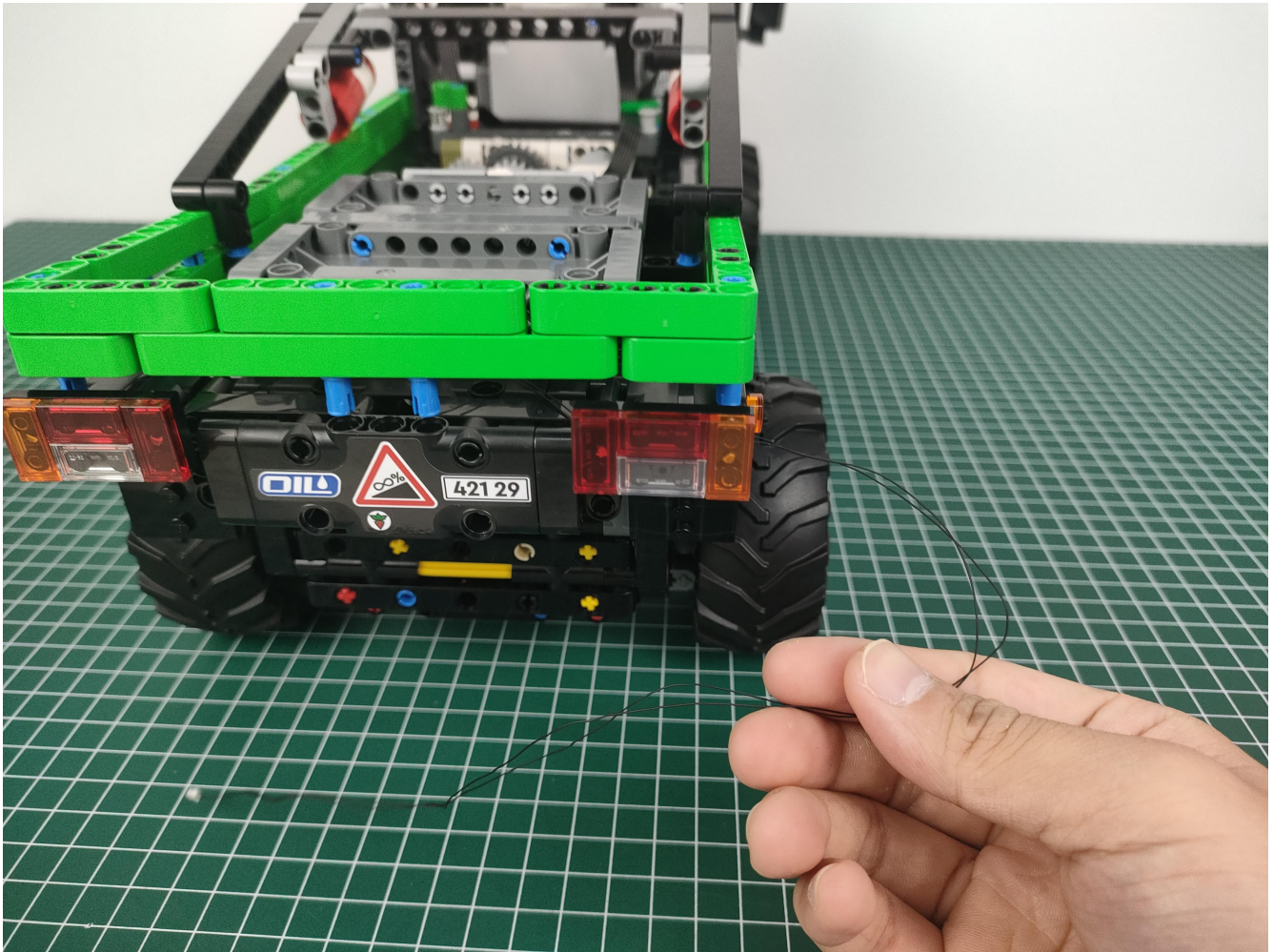

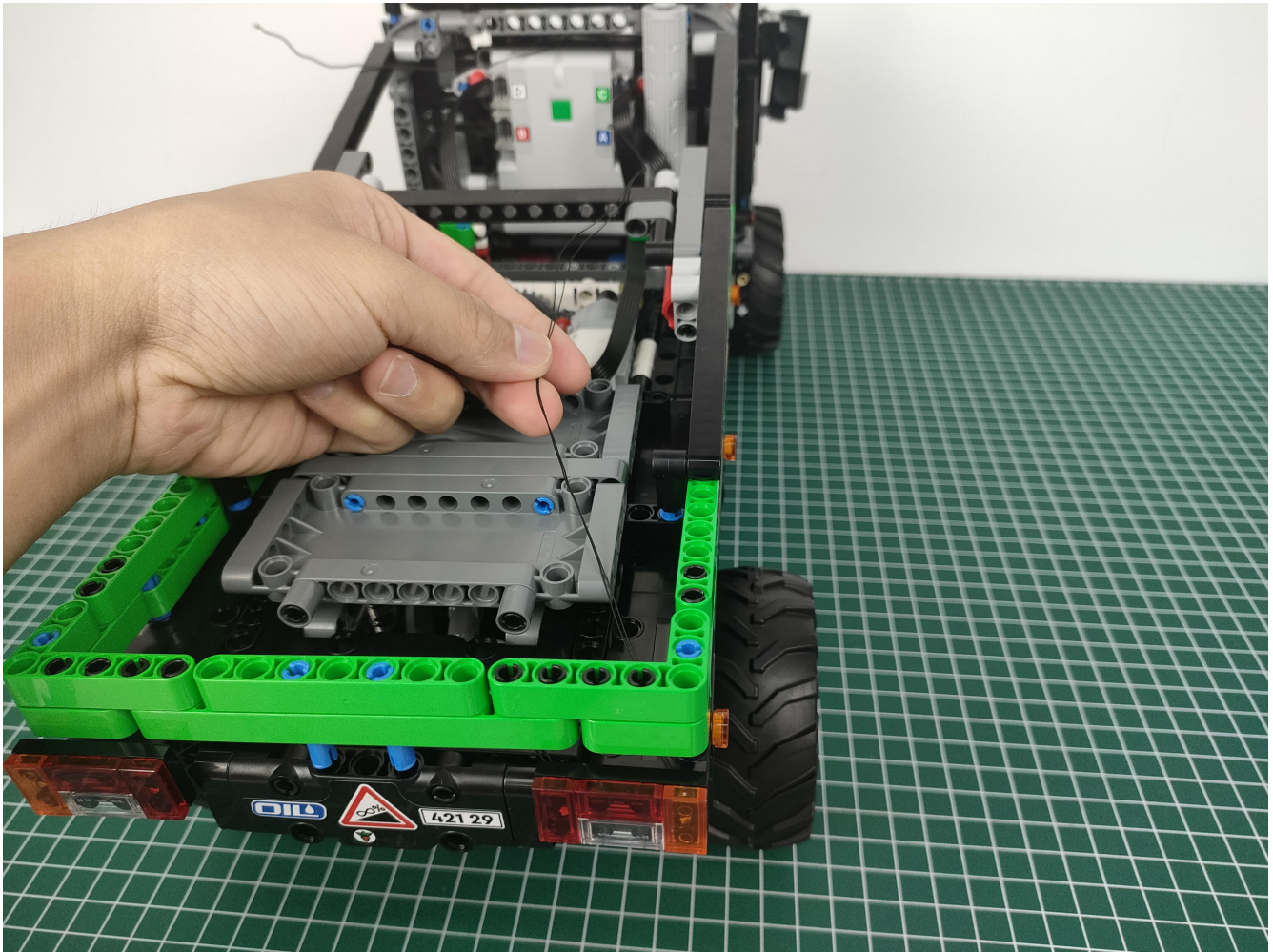

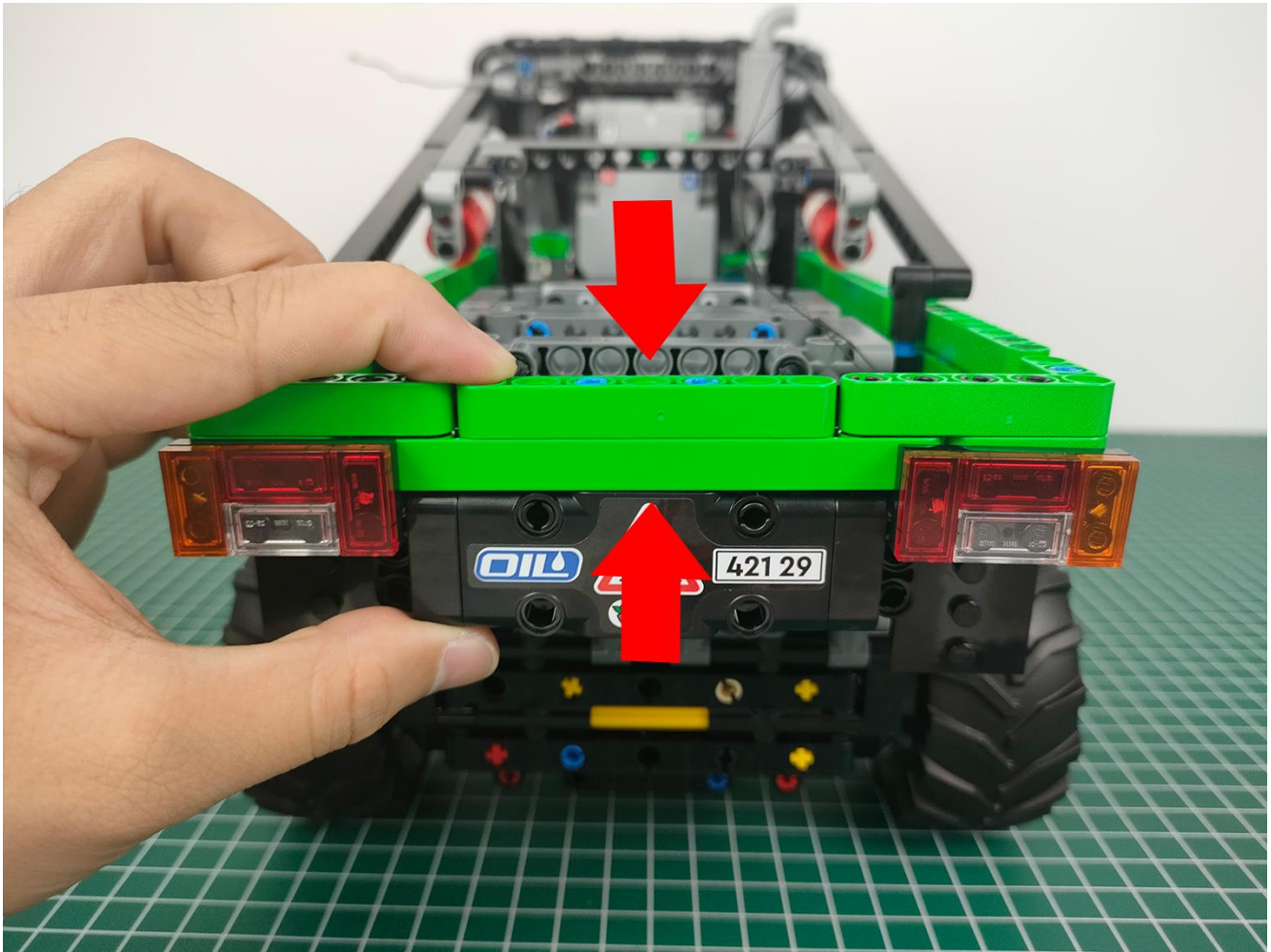

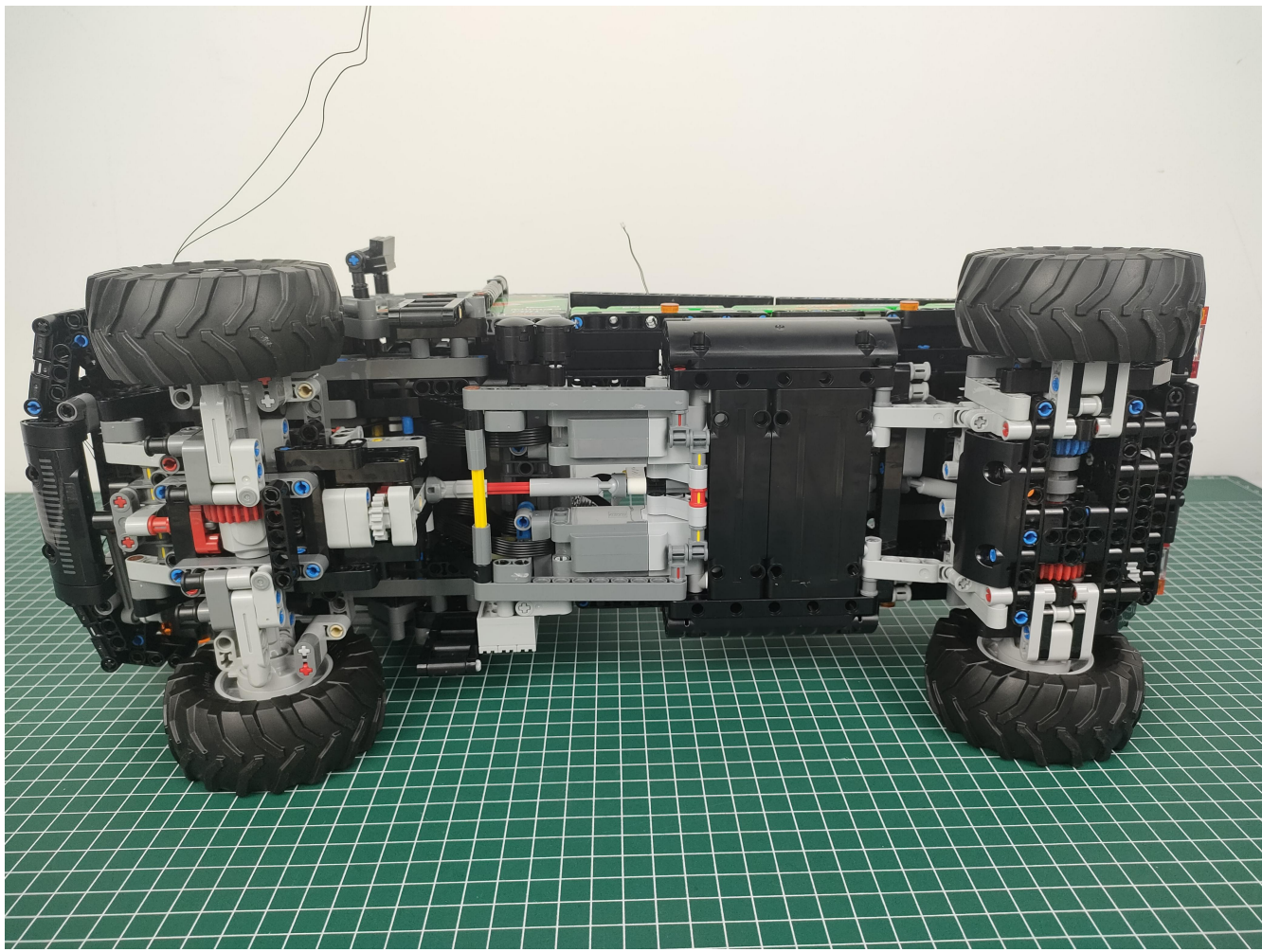

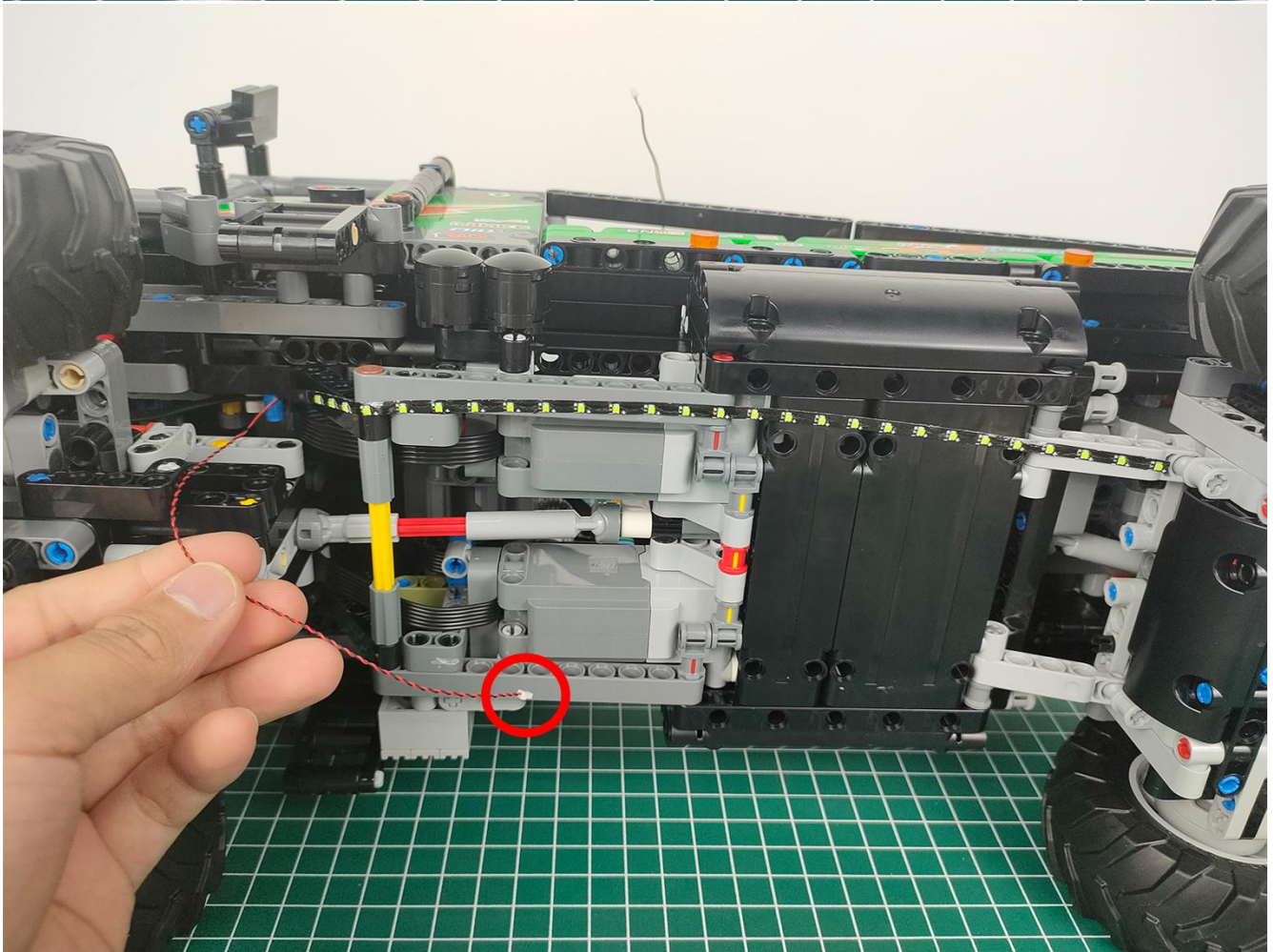
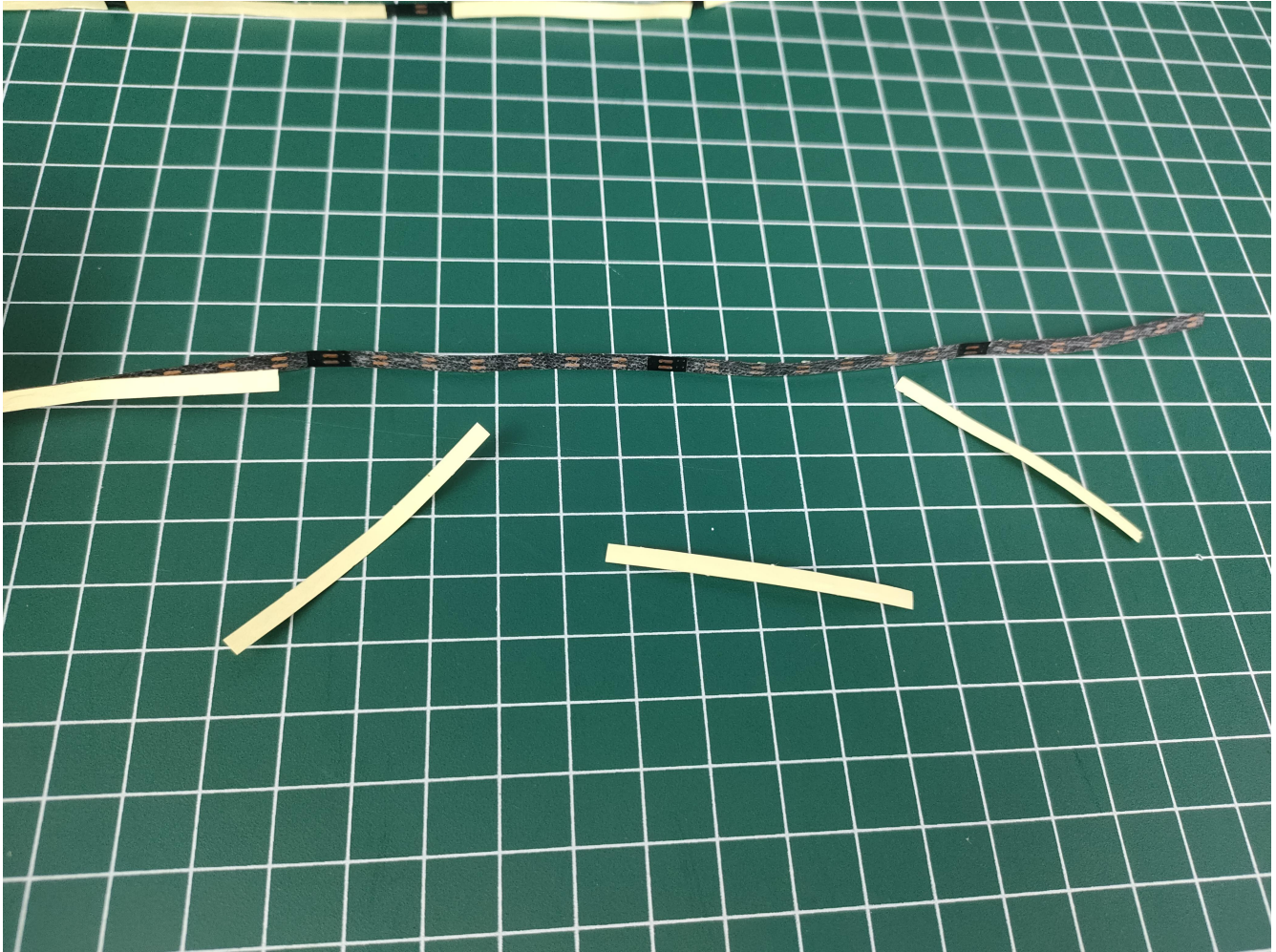

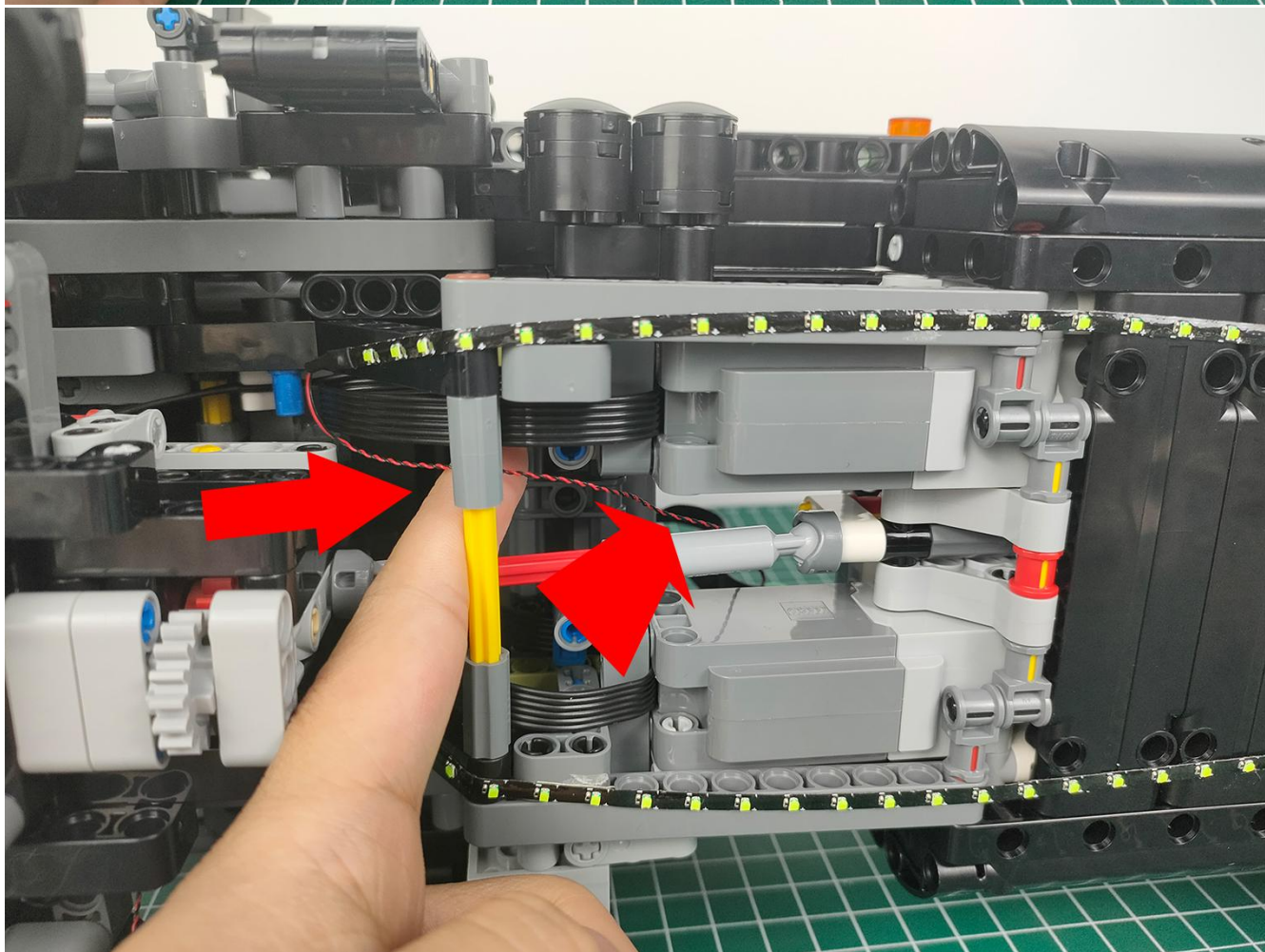
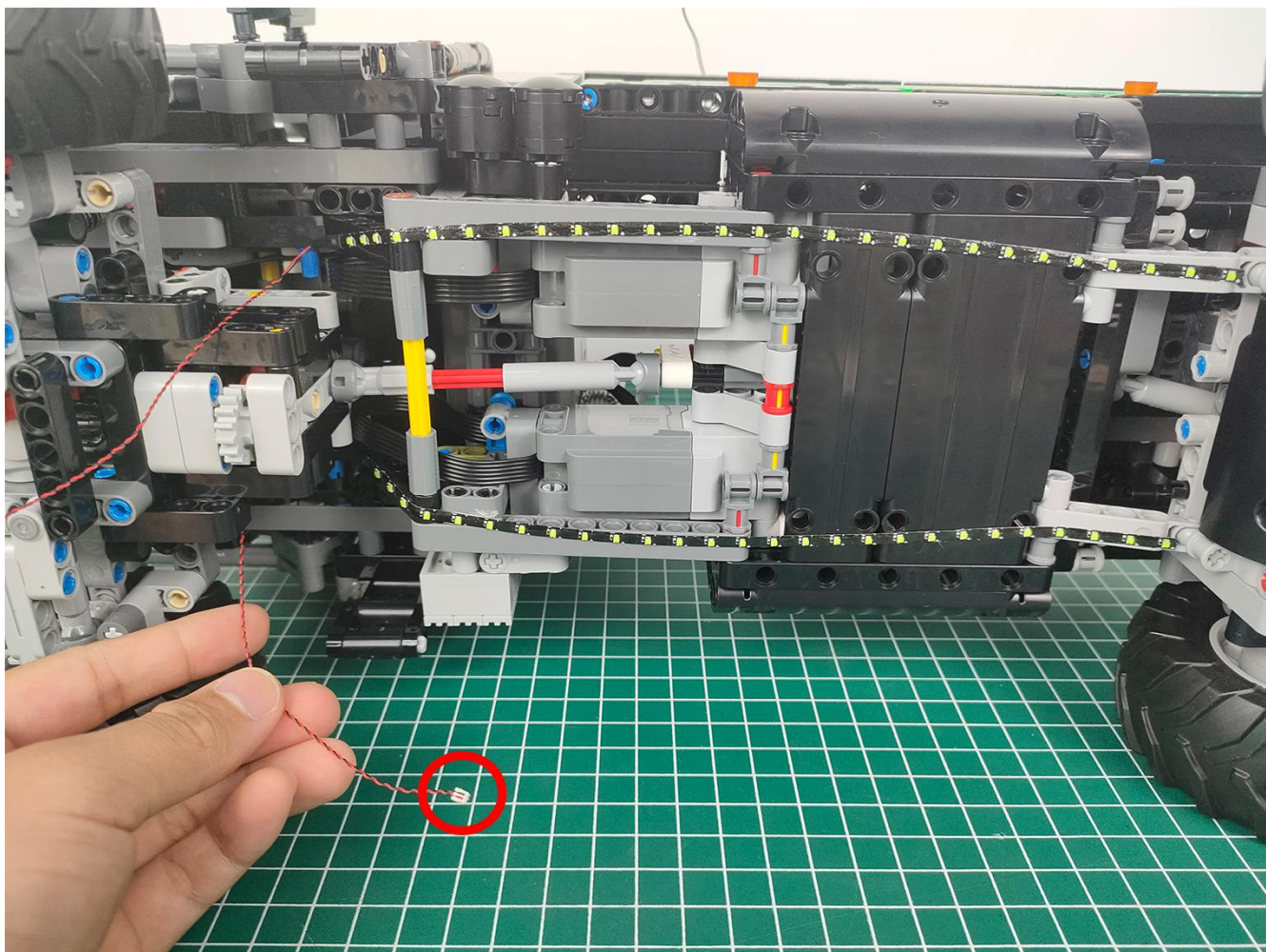



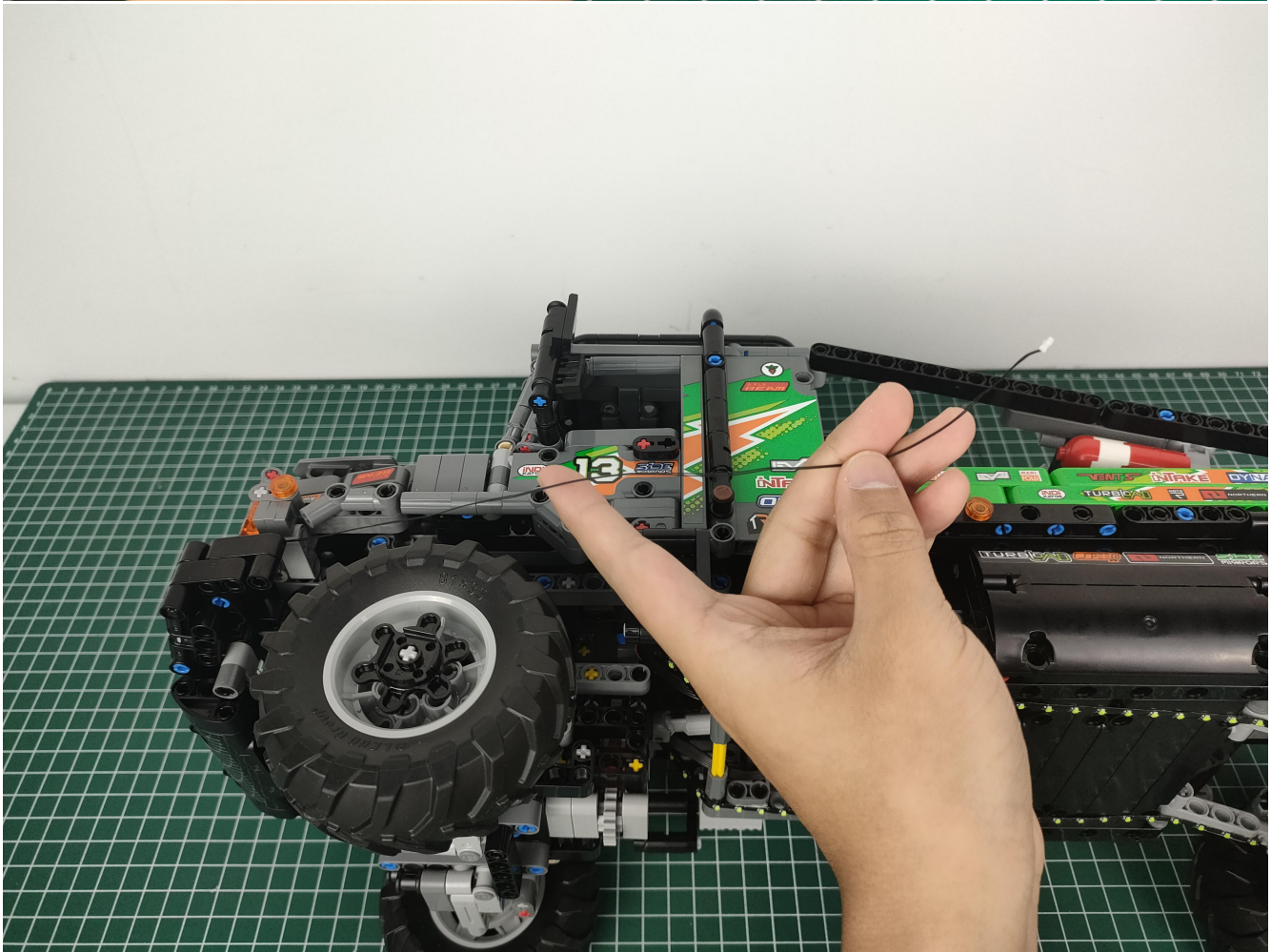
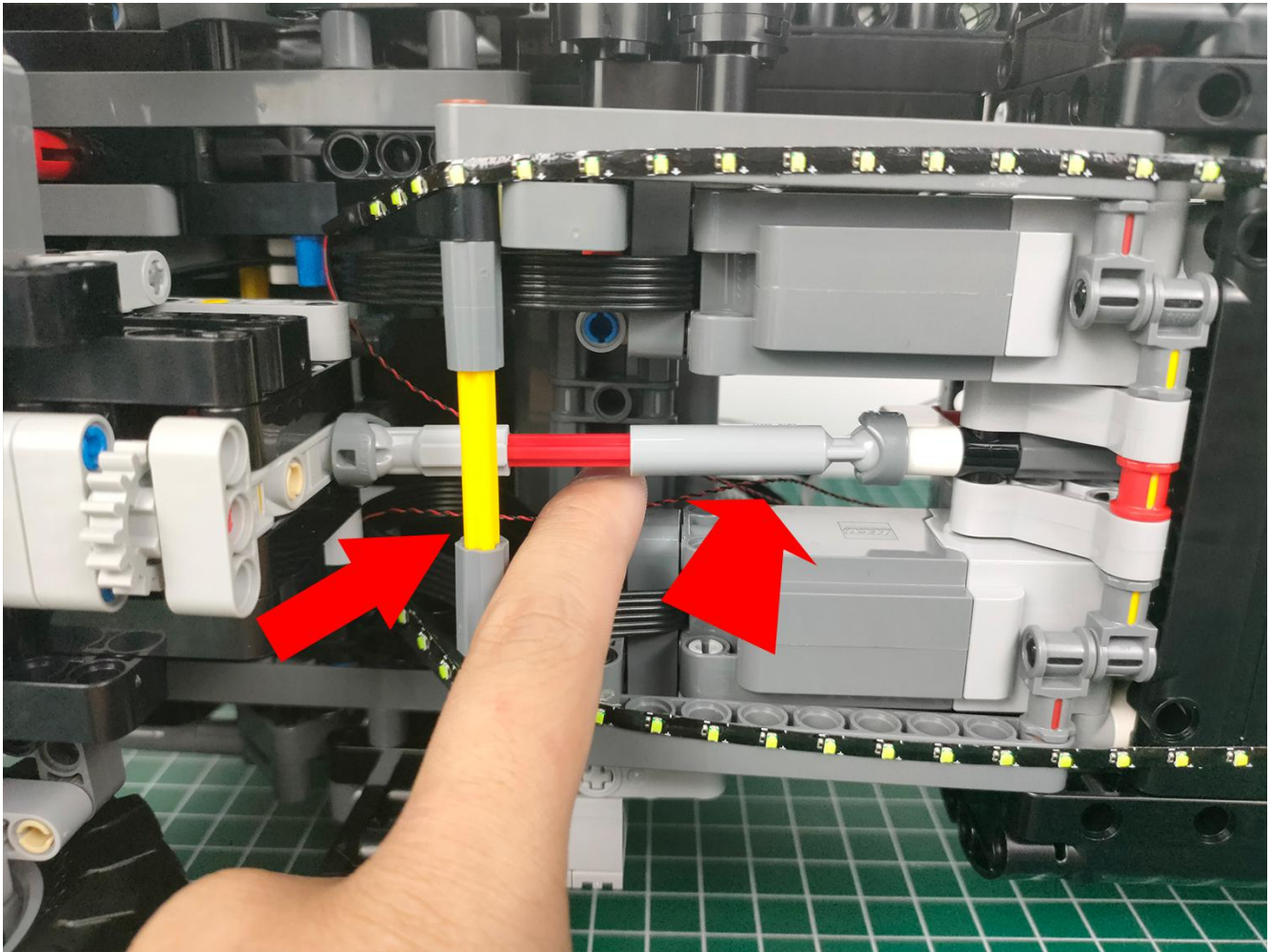

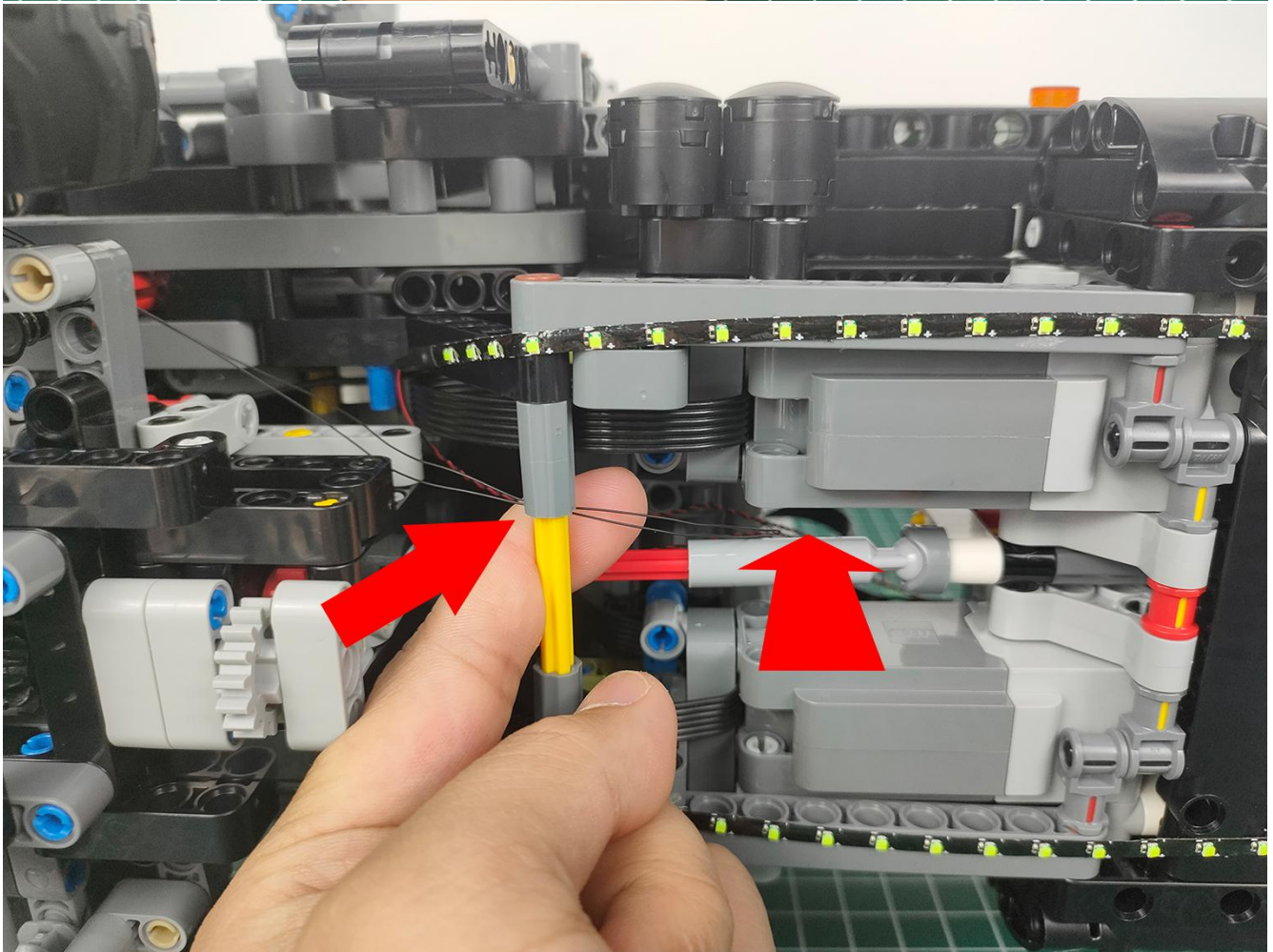
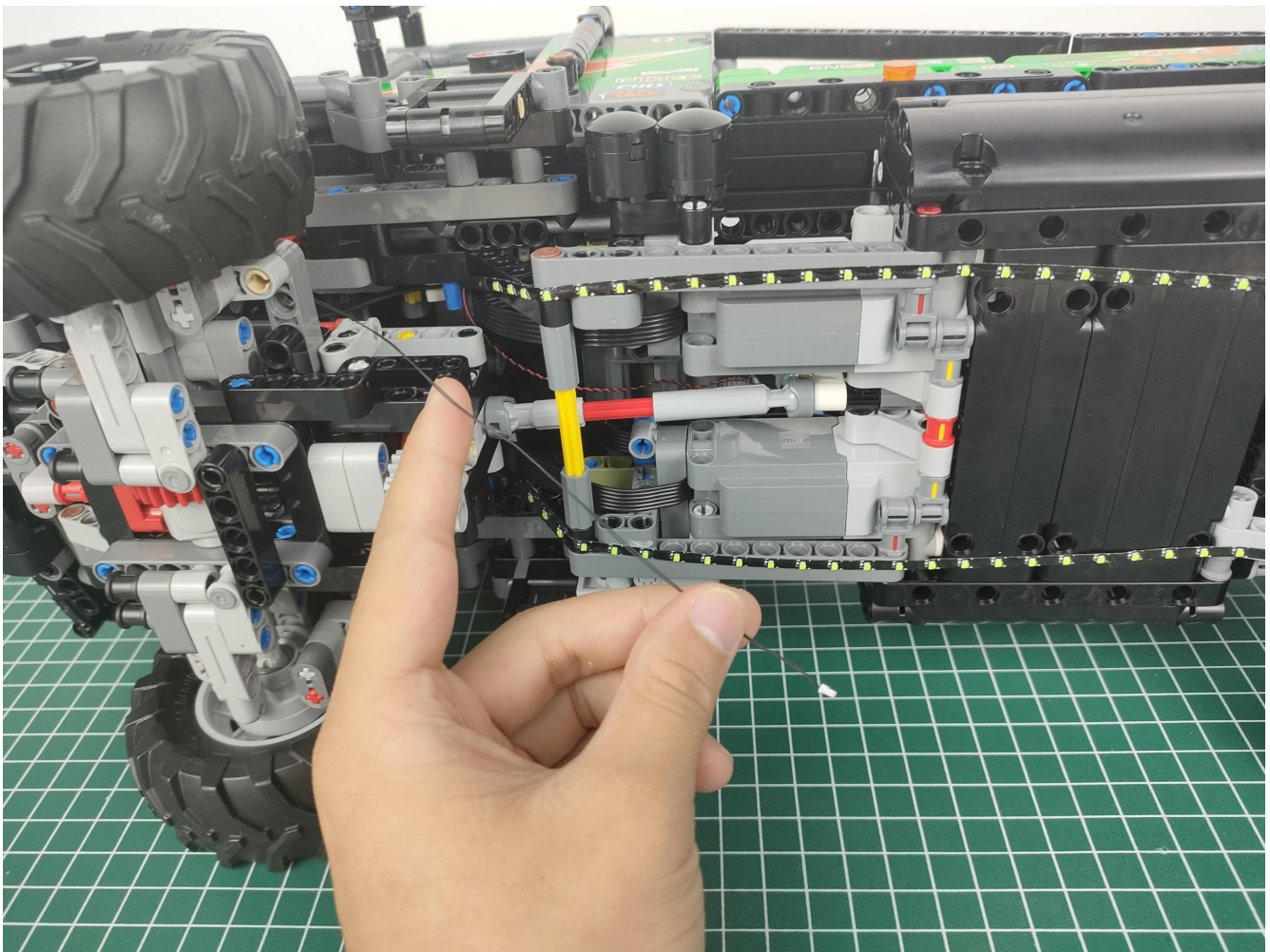



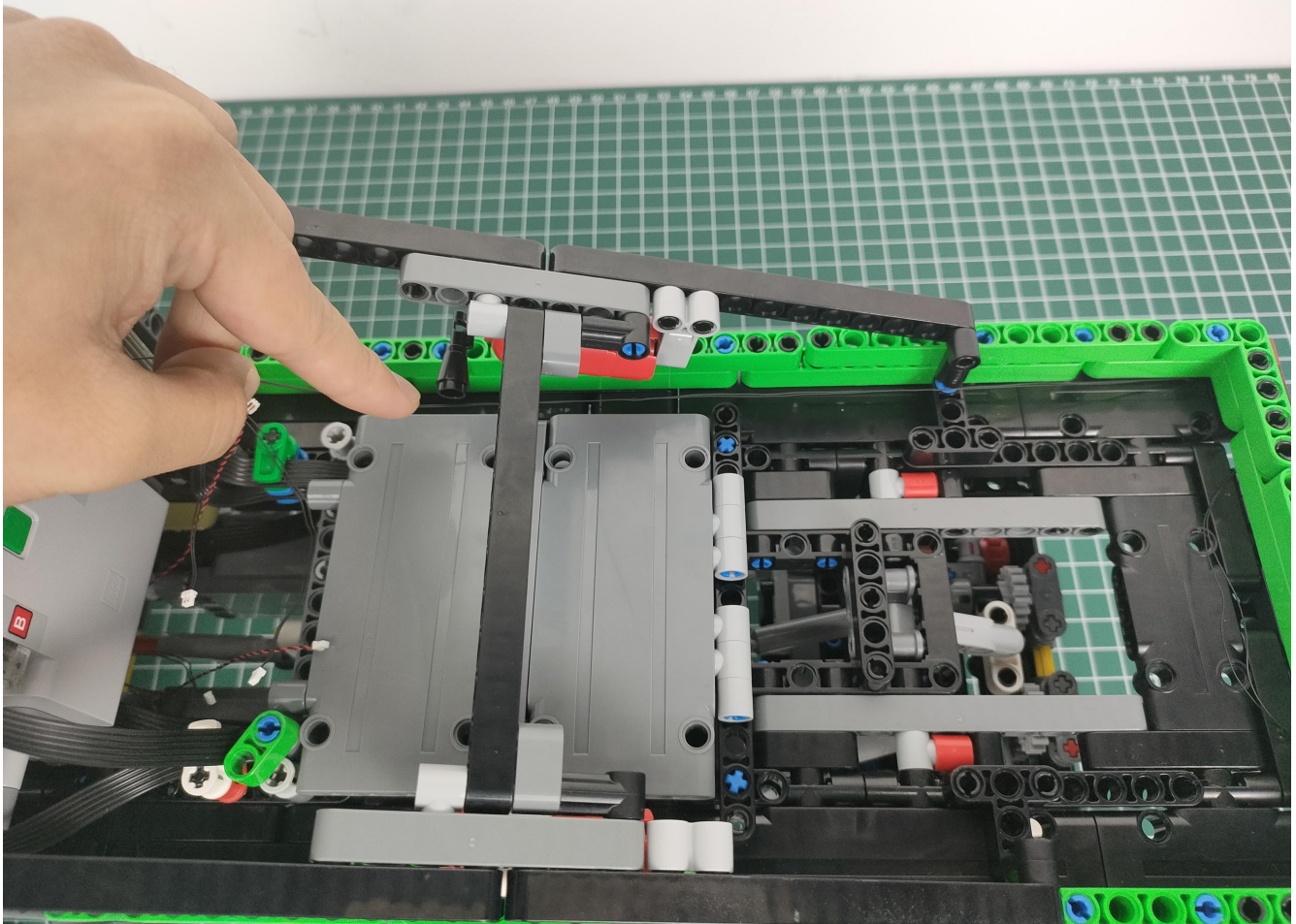
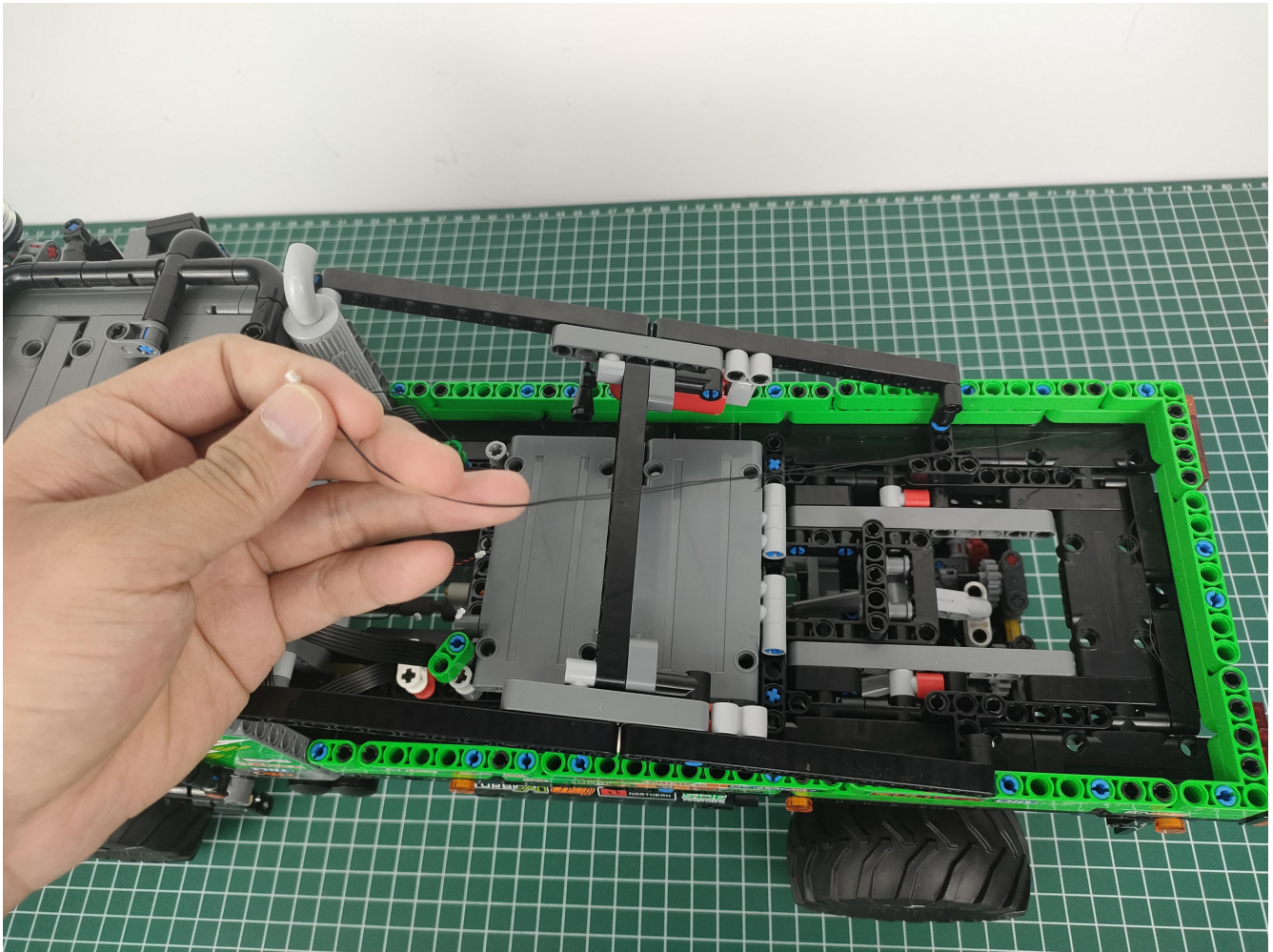

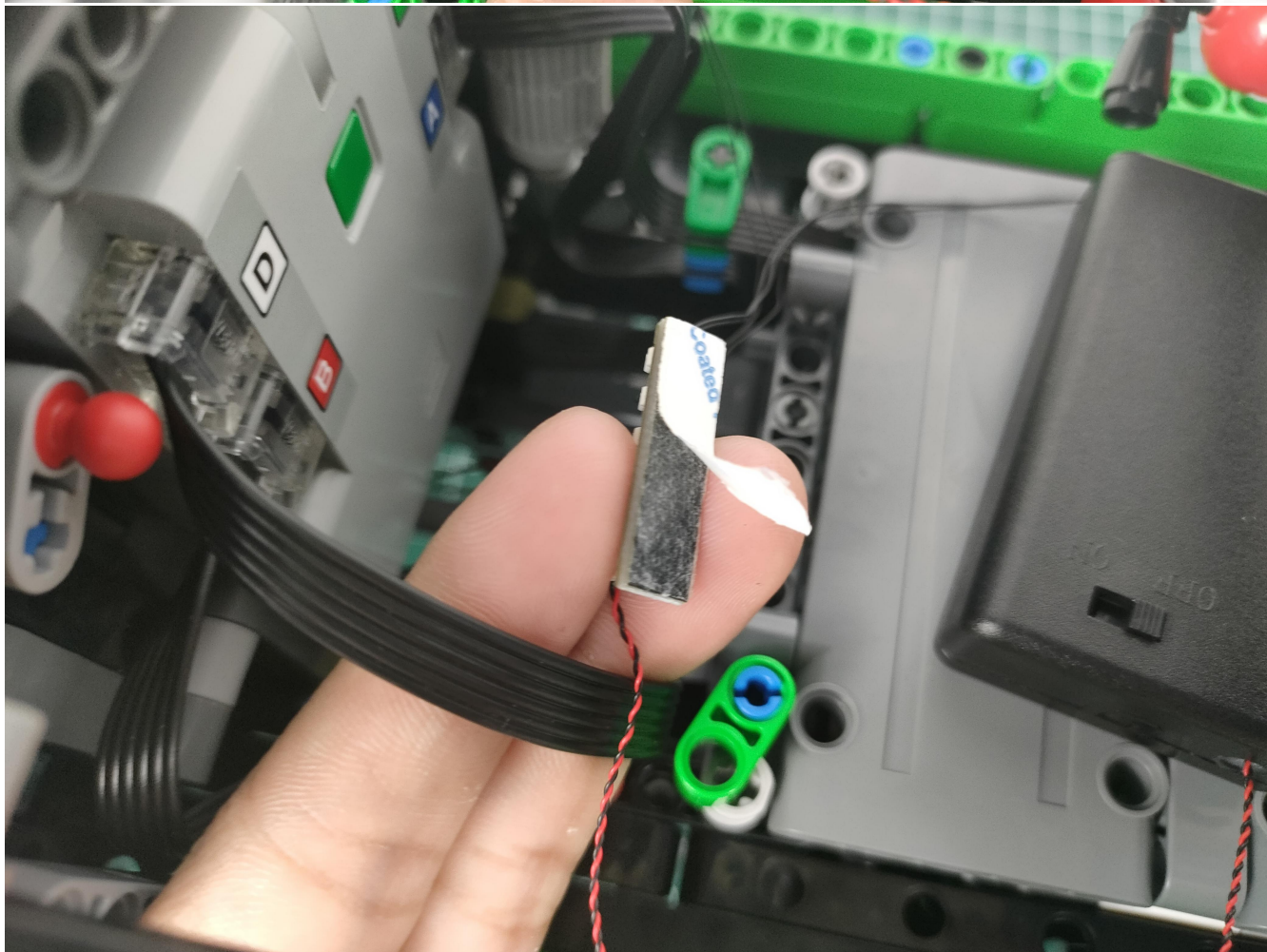
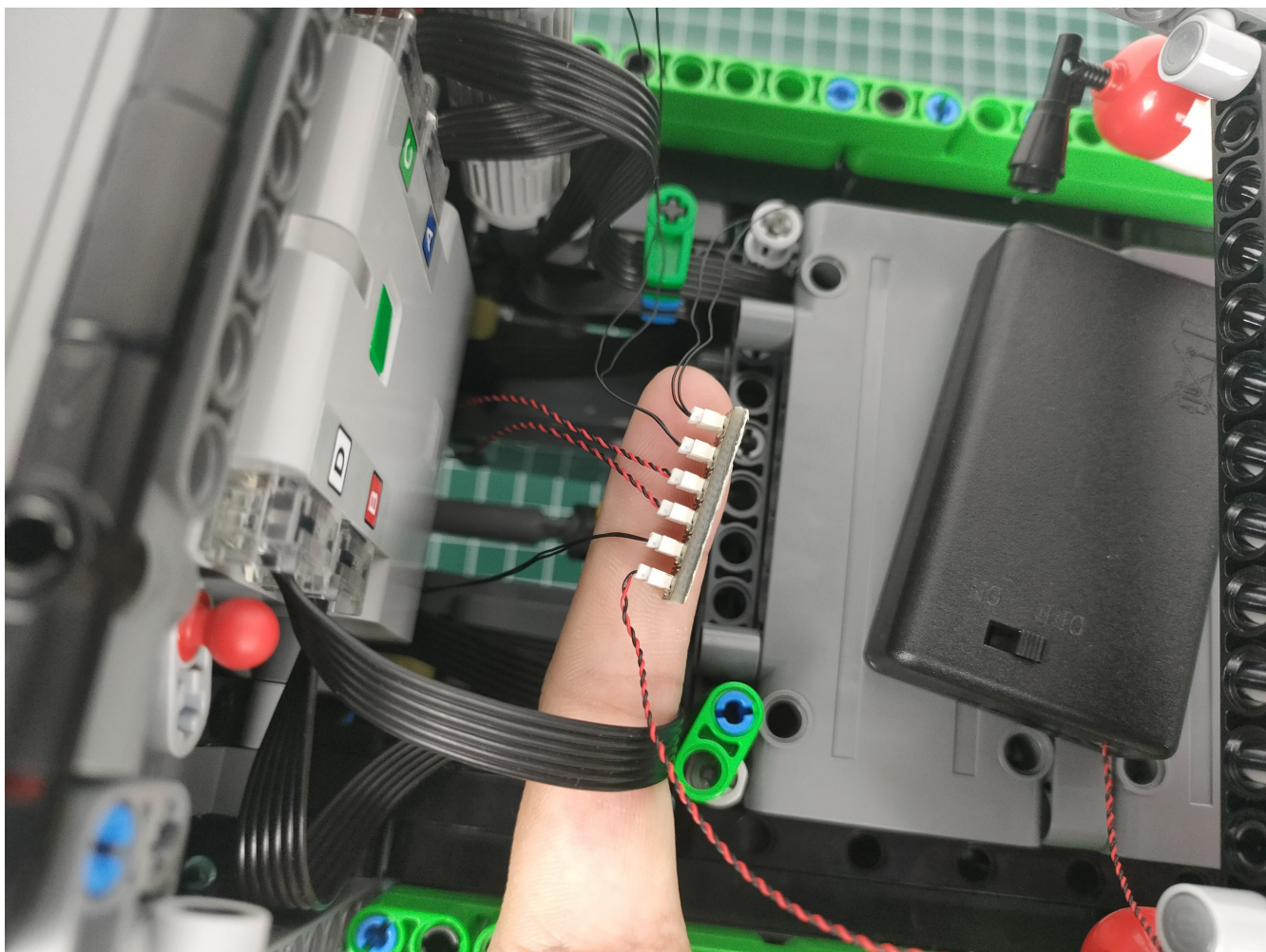

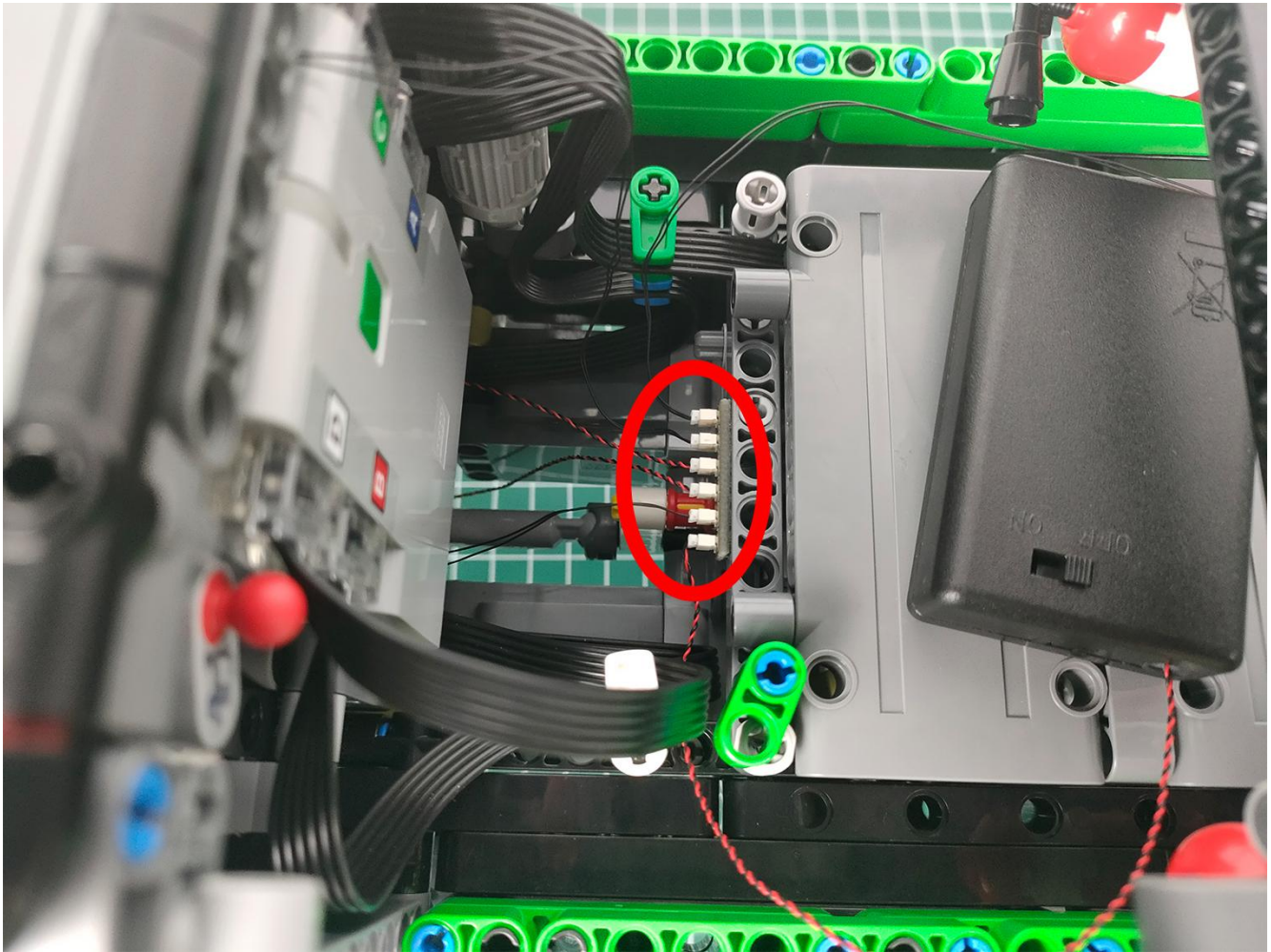

The installation is complete.

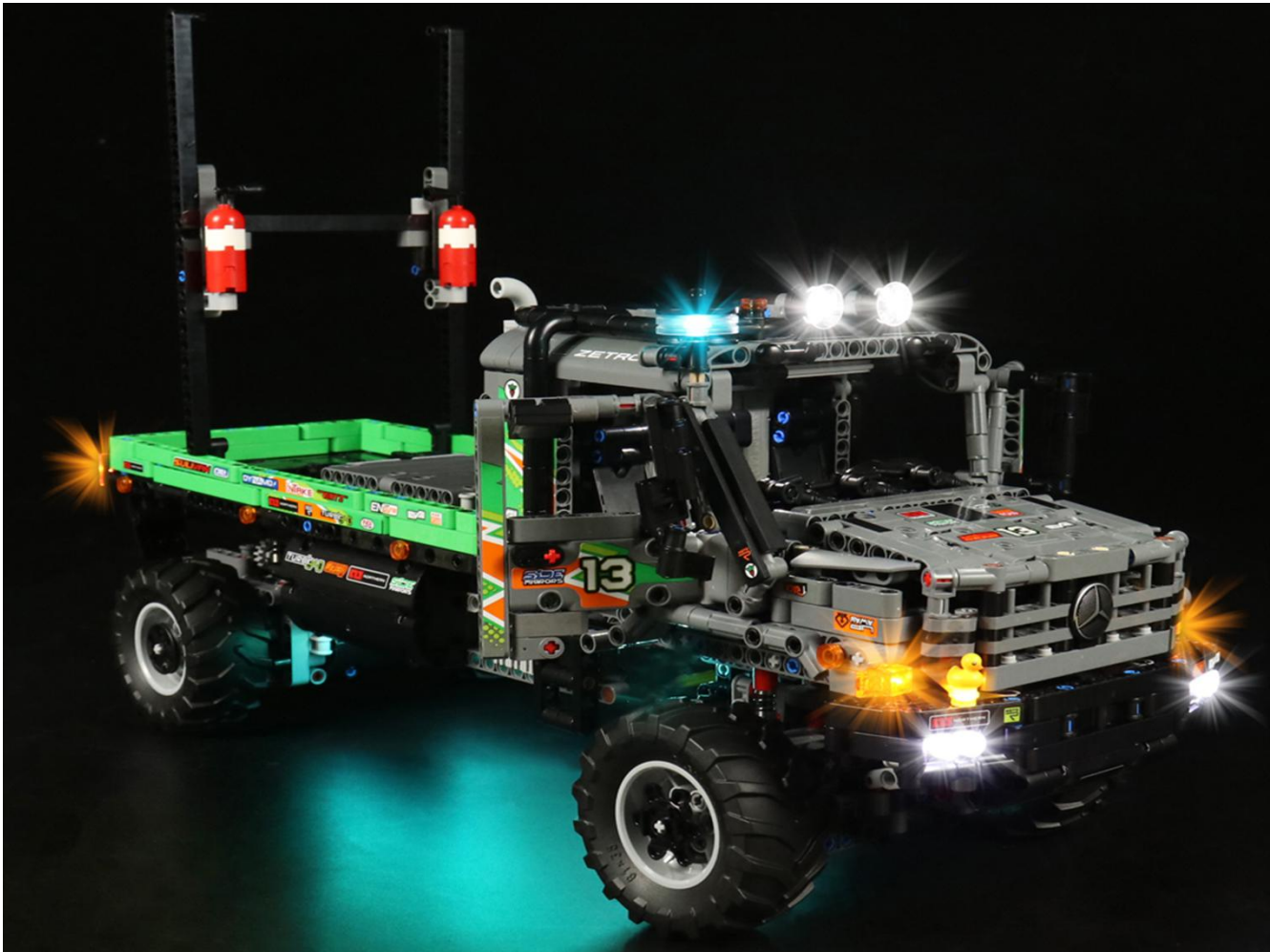

The above are ideas and instructions provided by our designers. Please move on:

- 1: Do you have any suggestions about the material and quality of our products?
- 2: Do you have any suggestions on the installation instructions and the degree of difficulty of the installation?
- 3: If you have better installation method and ideas, please contact us in time.