

# INSTALLATION GUIDE

## 43015 Lionel Messi – Football Legend



LED light kit compatible with Lego

# Instructions for installing this kit:

This set includes 8 pouches. (The battery case functions similarly; please select your own power source. This article uses a USB power cable.)

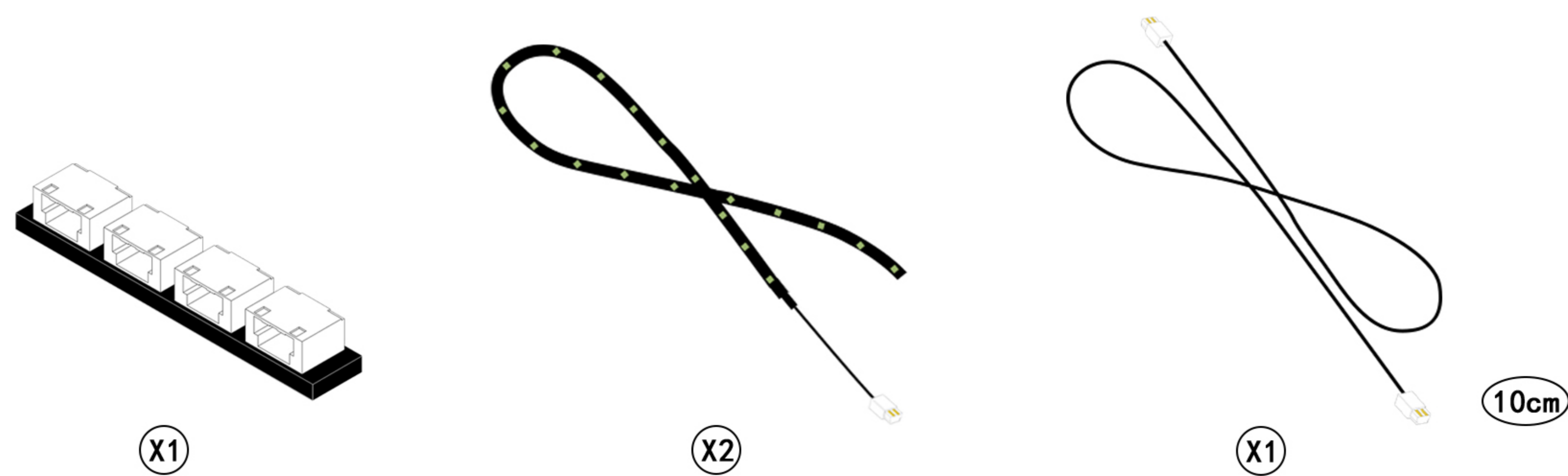
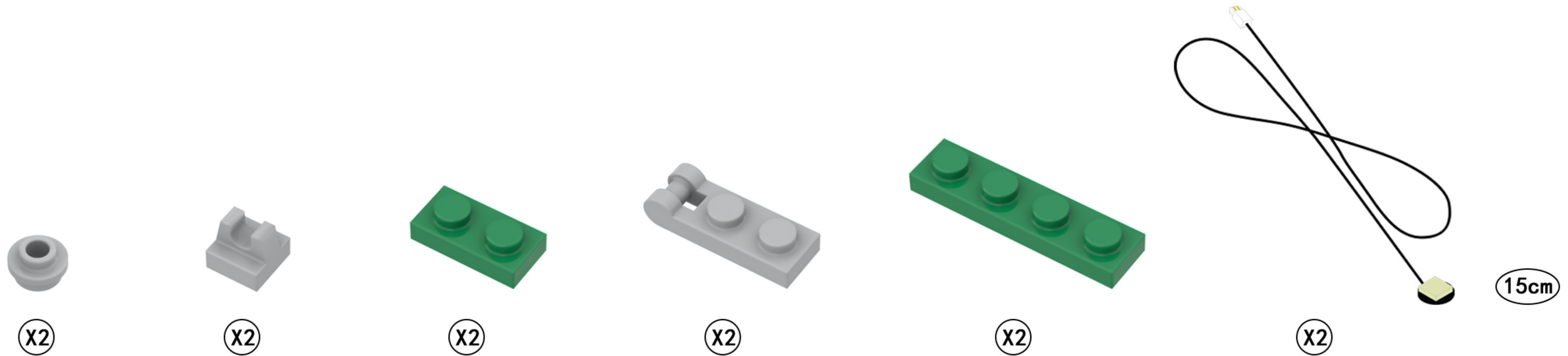
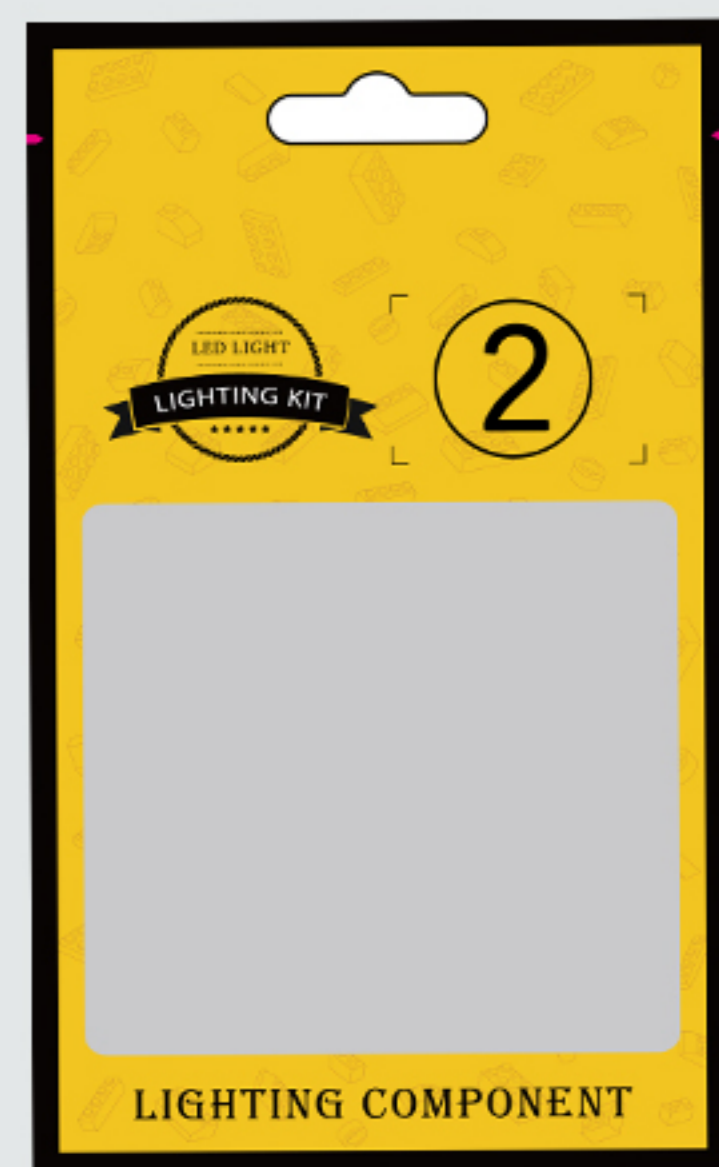
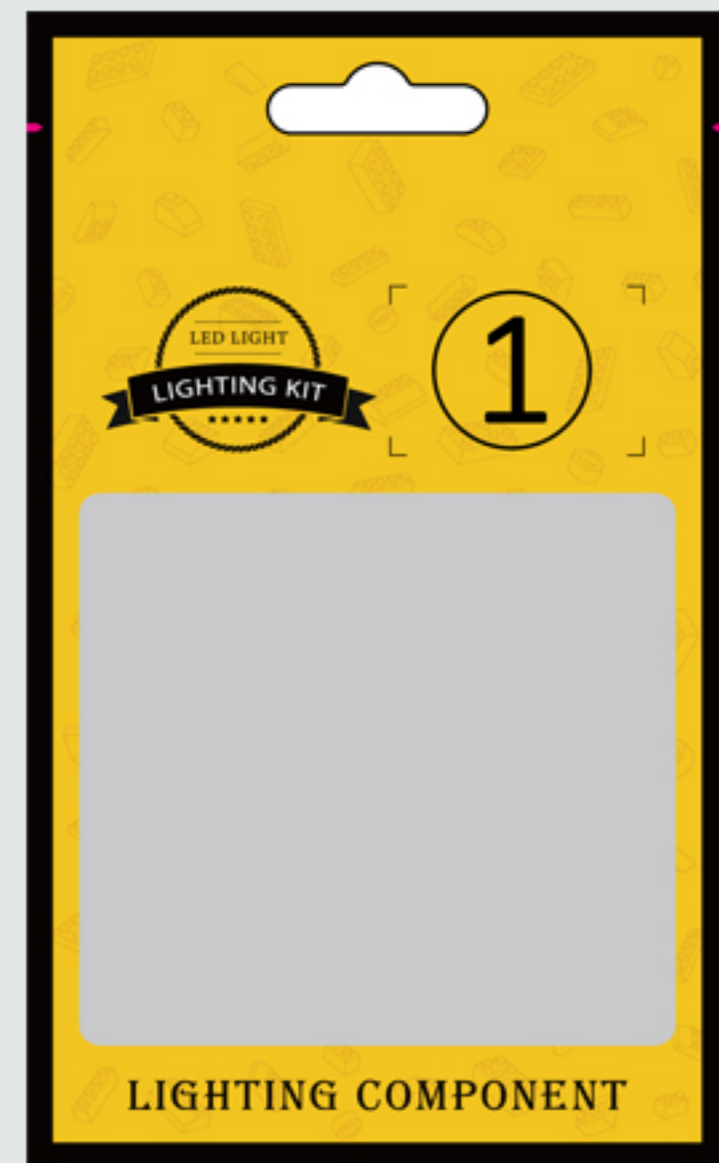

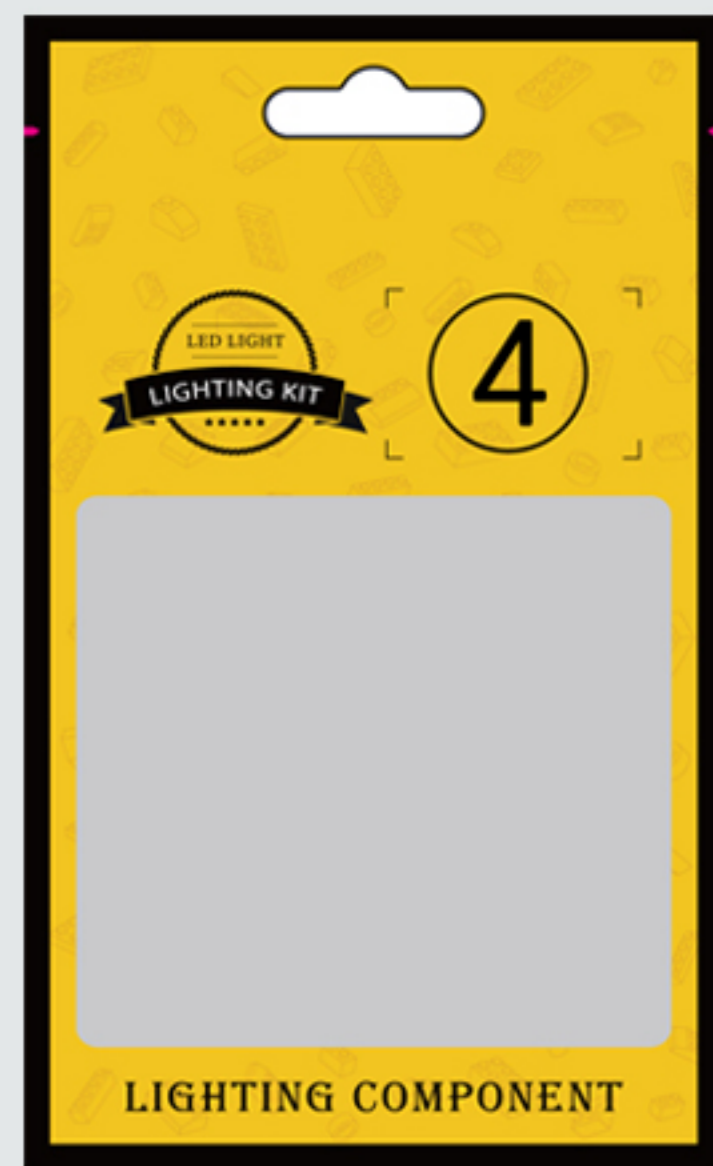

(X1)



(X1)

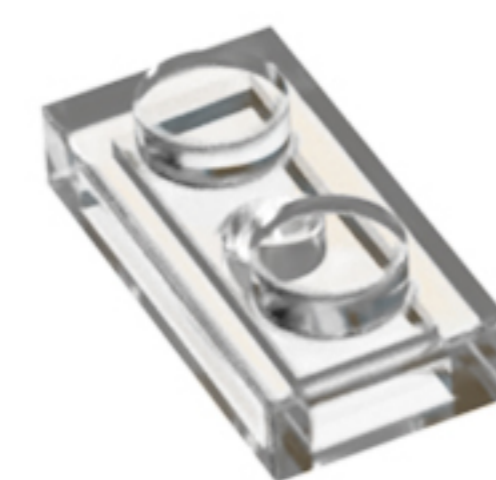
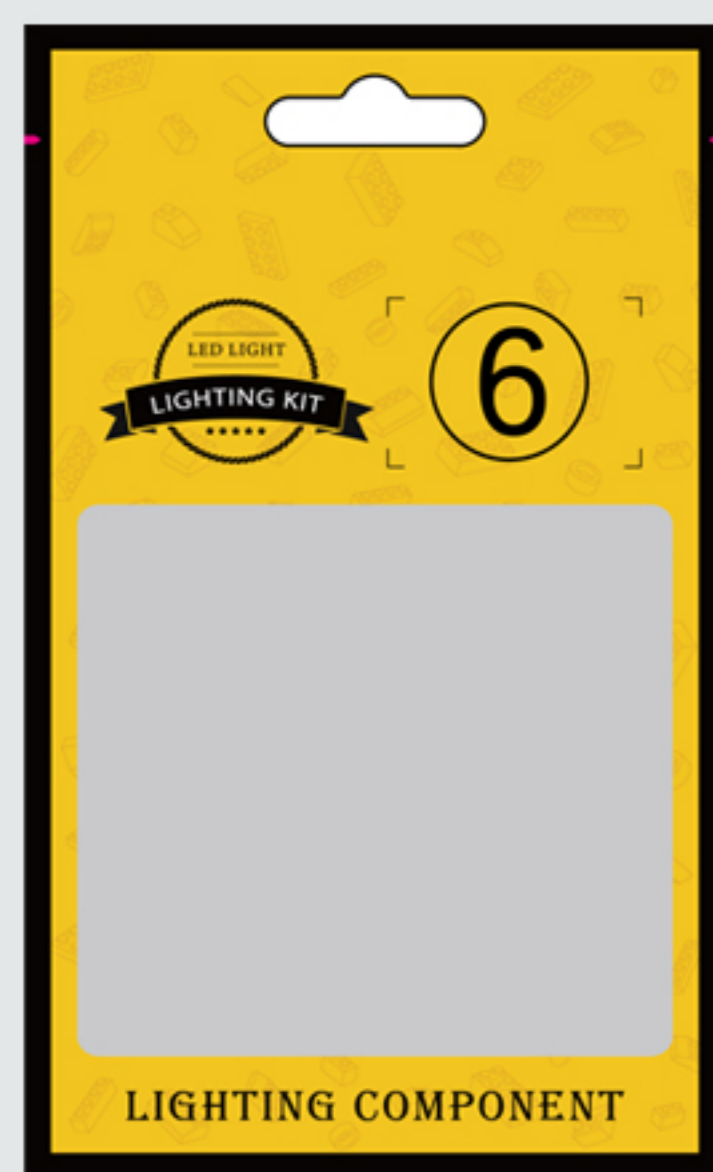

(X3)

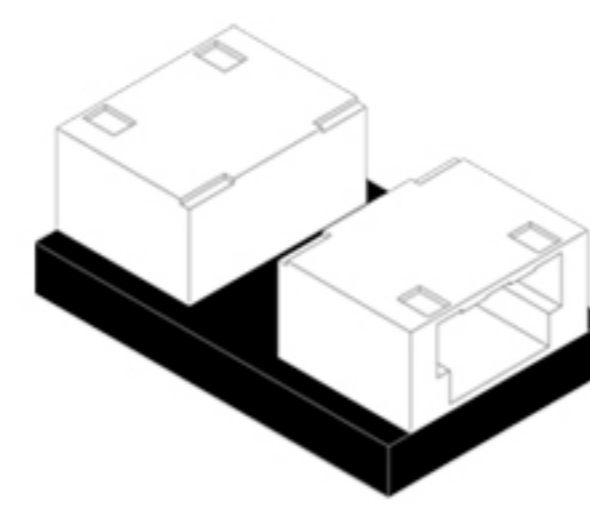

(X1)

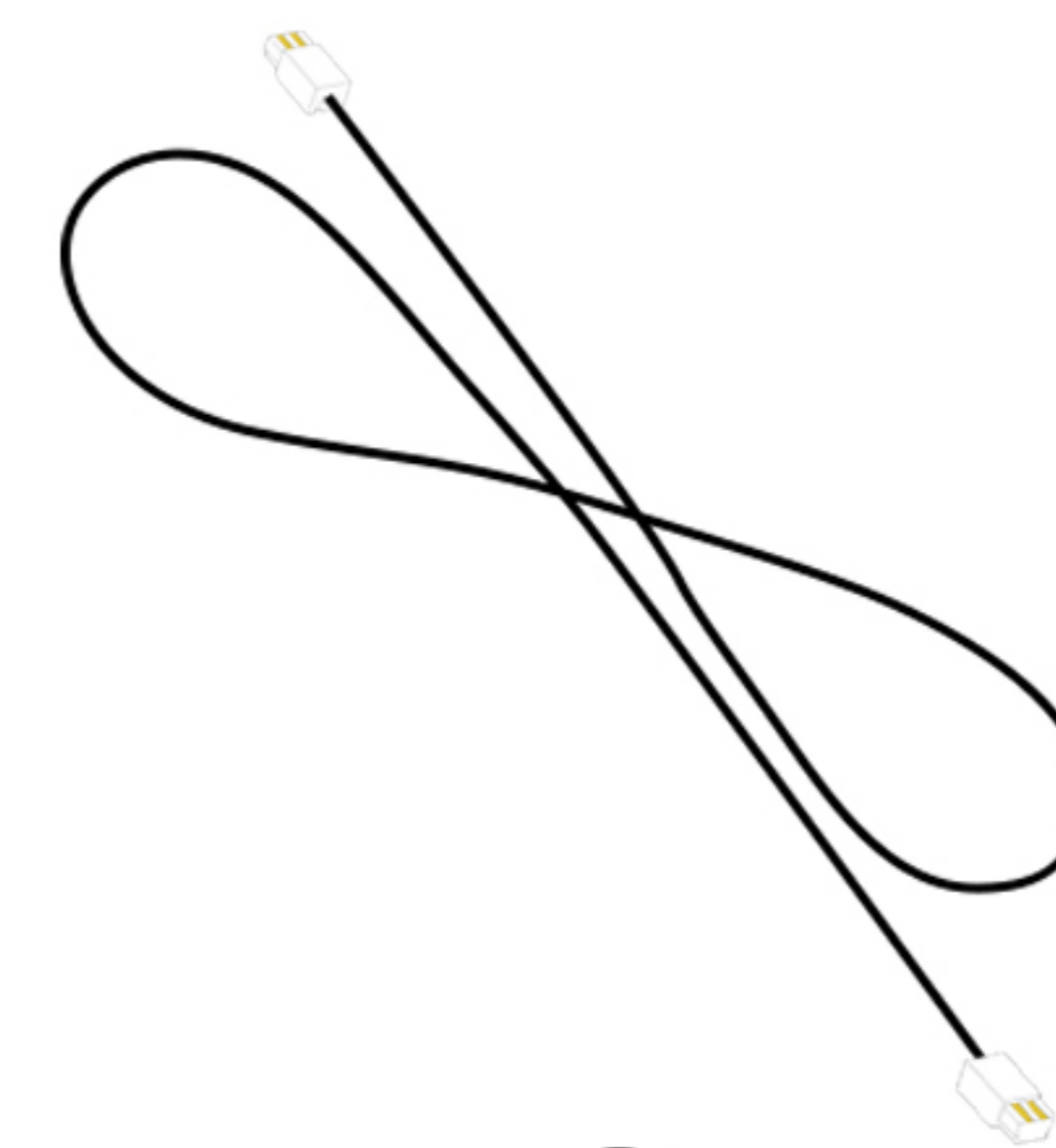

(X1)

(20cm)

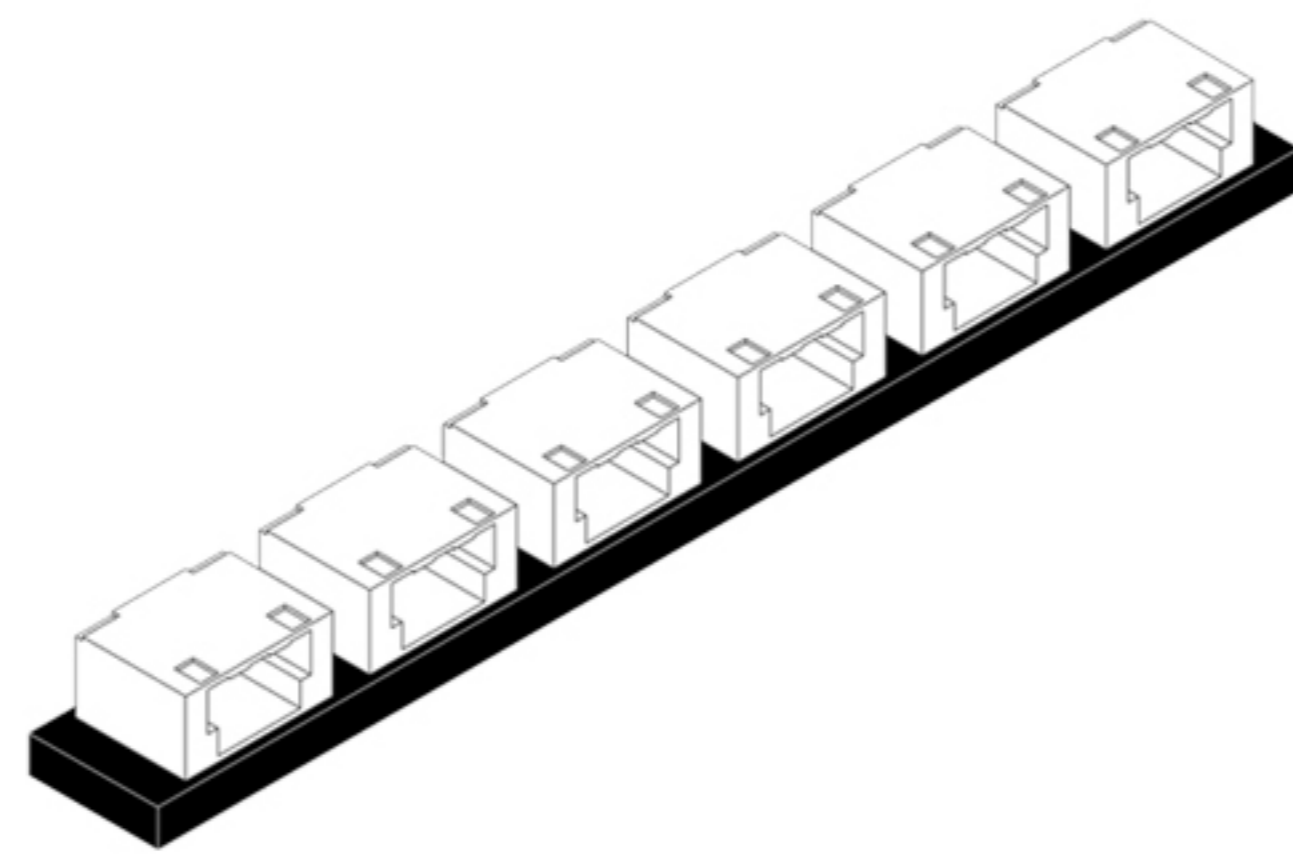

X1



X1

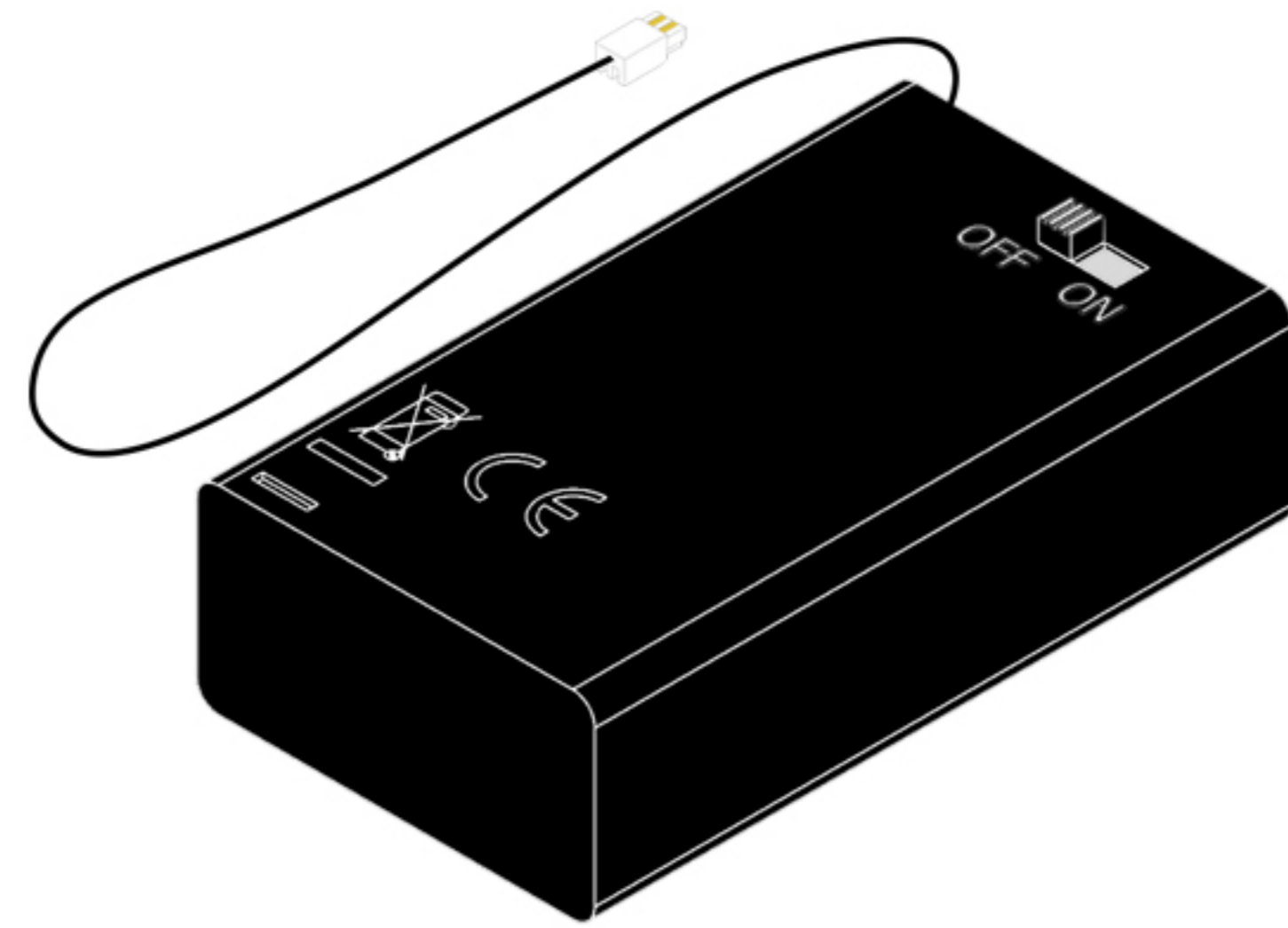
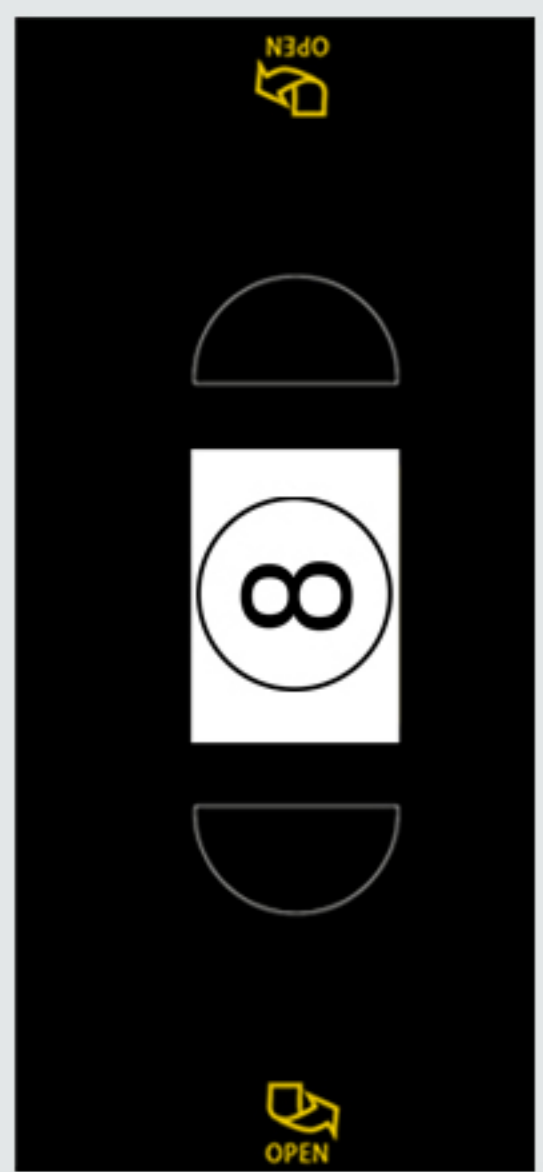

X1

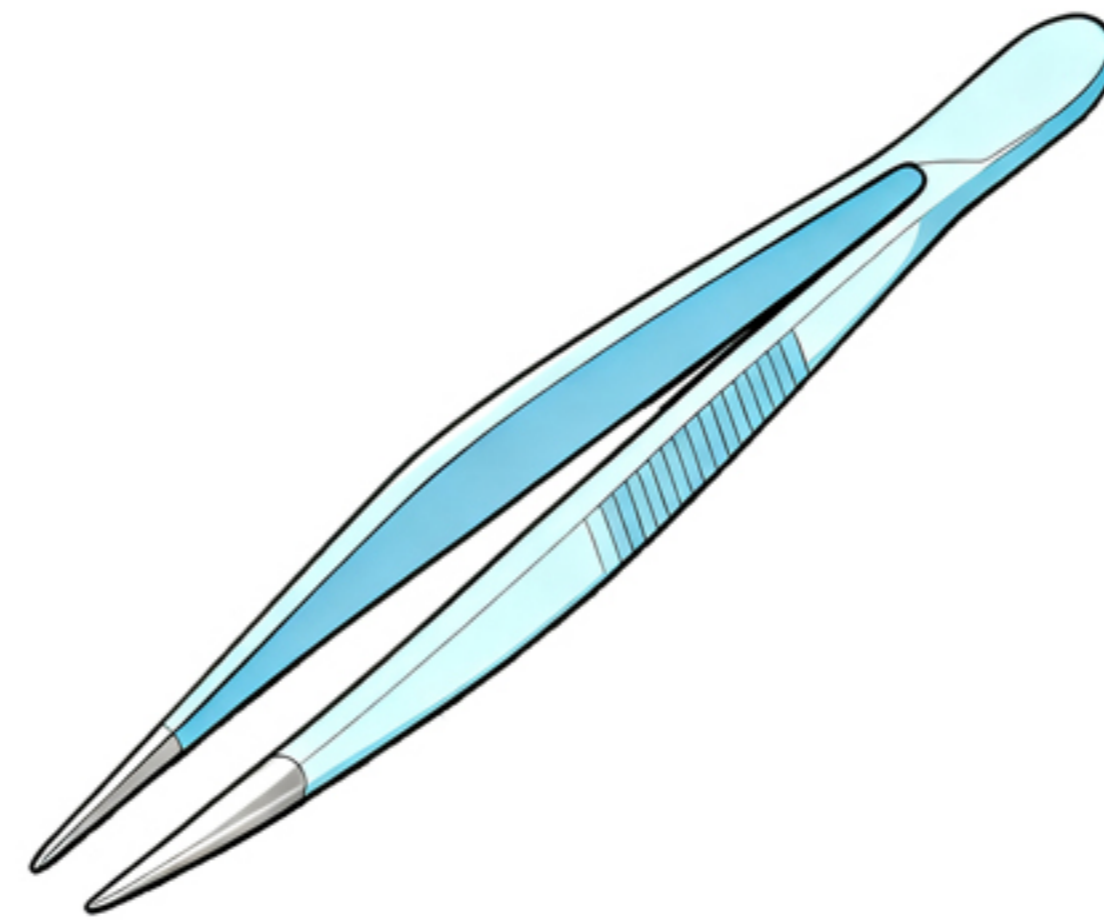

X1

This post will complete the light installation in two main sections.

Step 1-test



Step 2-mounting

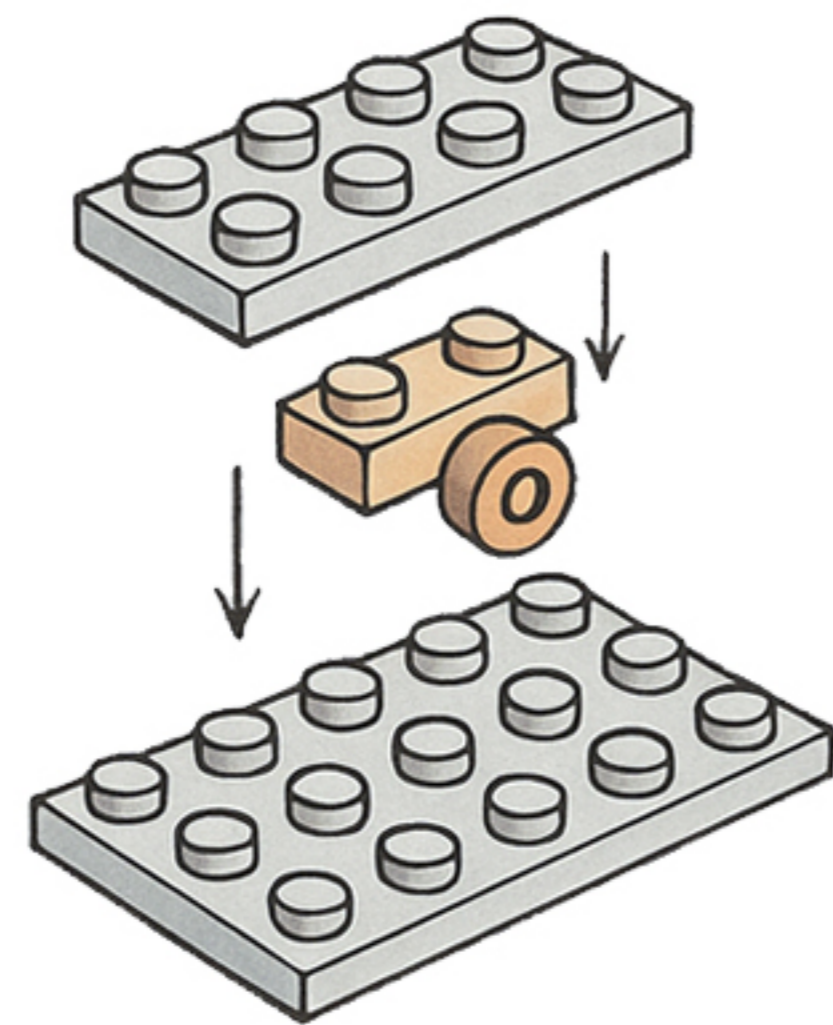

So let's get started!

## Step 1-Test.

1

EN: Take out the touch dimmer module from Bag 7.

DE: Nehmen Sie das Touch-Dimmer-Modul aus Beutel 7 heraus.

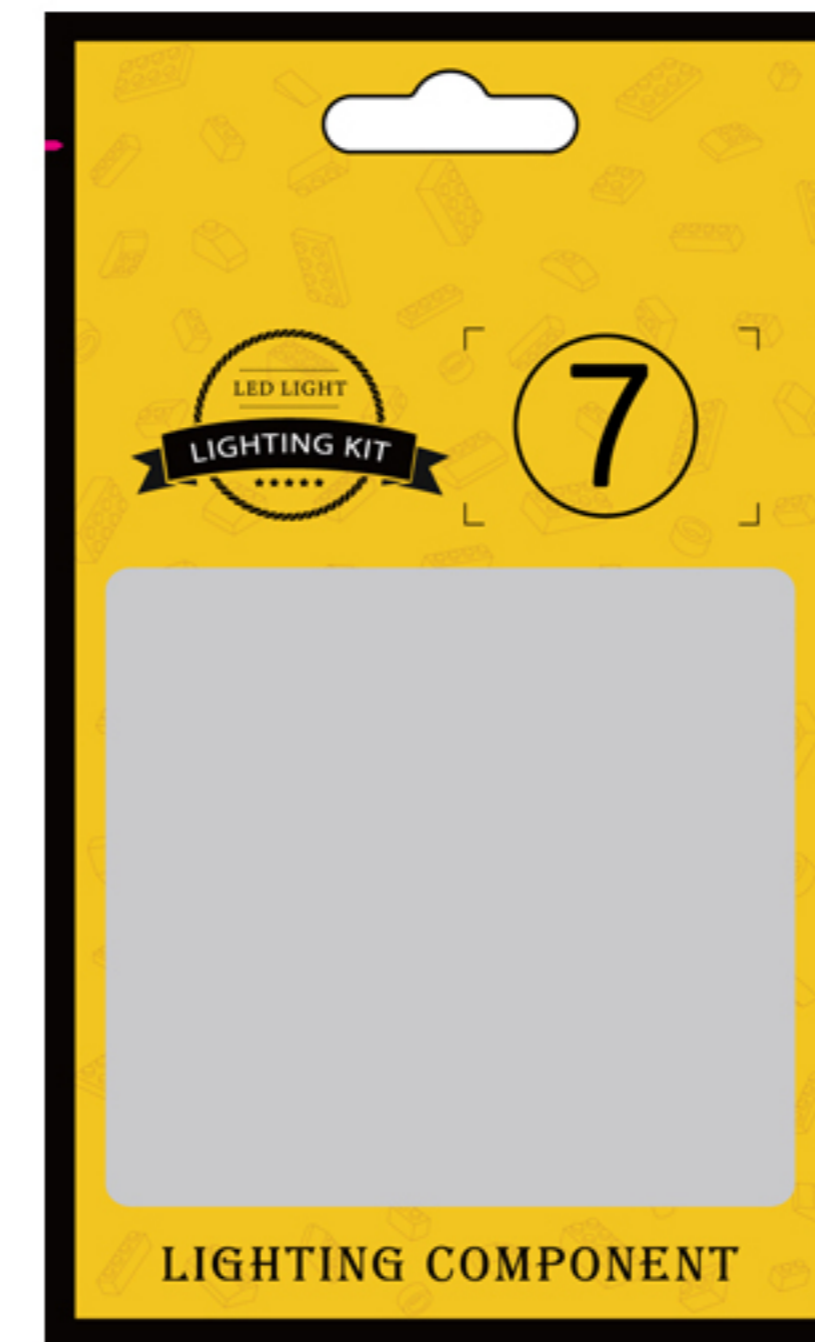

### Touch Dimmer Module - 200CM Introduce

Cable length 50cm

Cable length 150cm

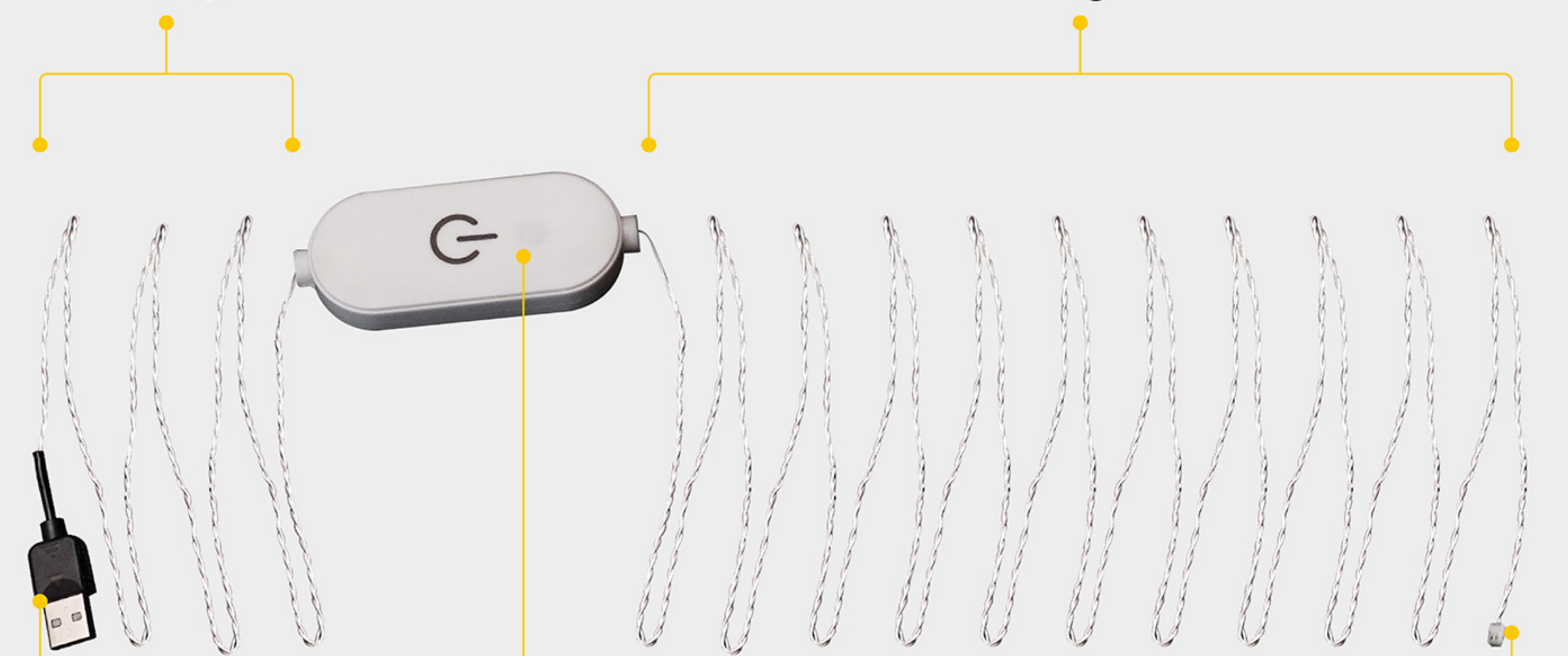

USB power input (5V)

Touch dimmer module:  
When the light is on, long press to  
adjust the brightness of the light

Output (5V)

2

EN: Take the expansion board out of Bag 7 and connect the touch dimming module to it.

DE: Nehmen Sie die Erweiterungskarte aus Beutel 7 und schließen Sie das Touch-Dimmmodul daran an.

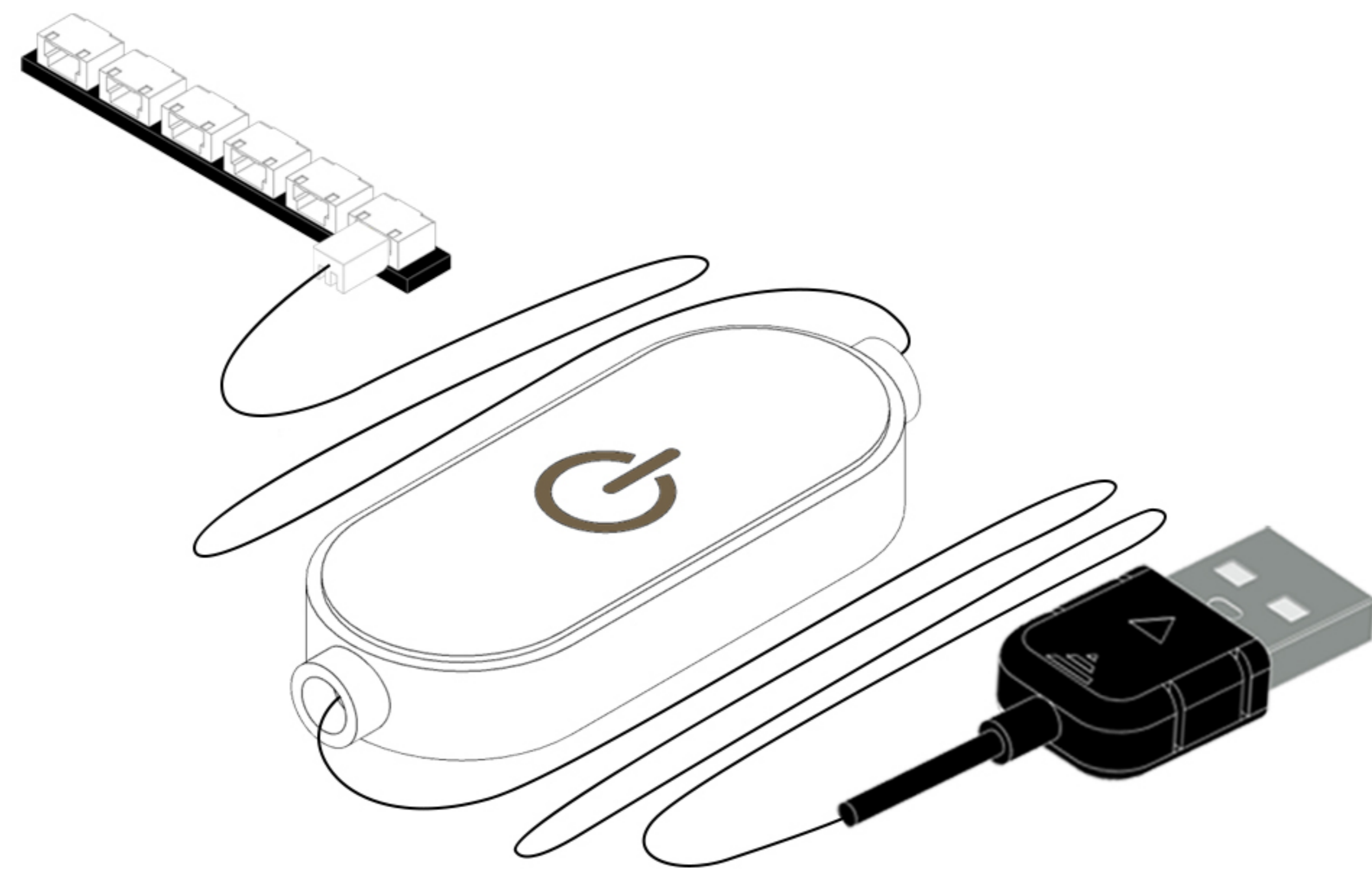
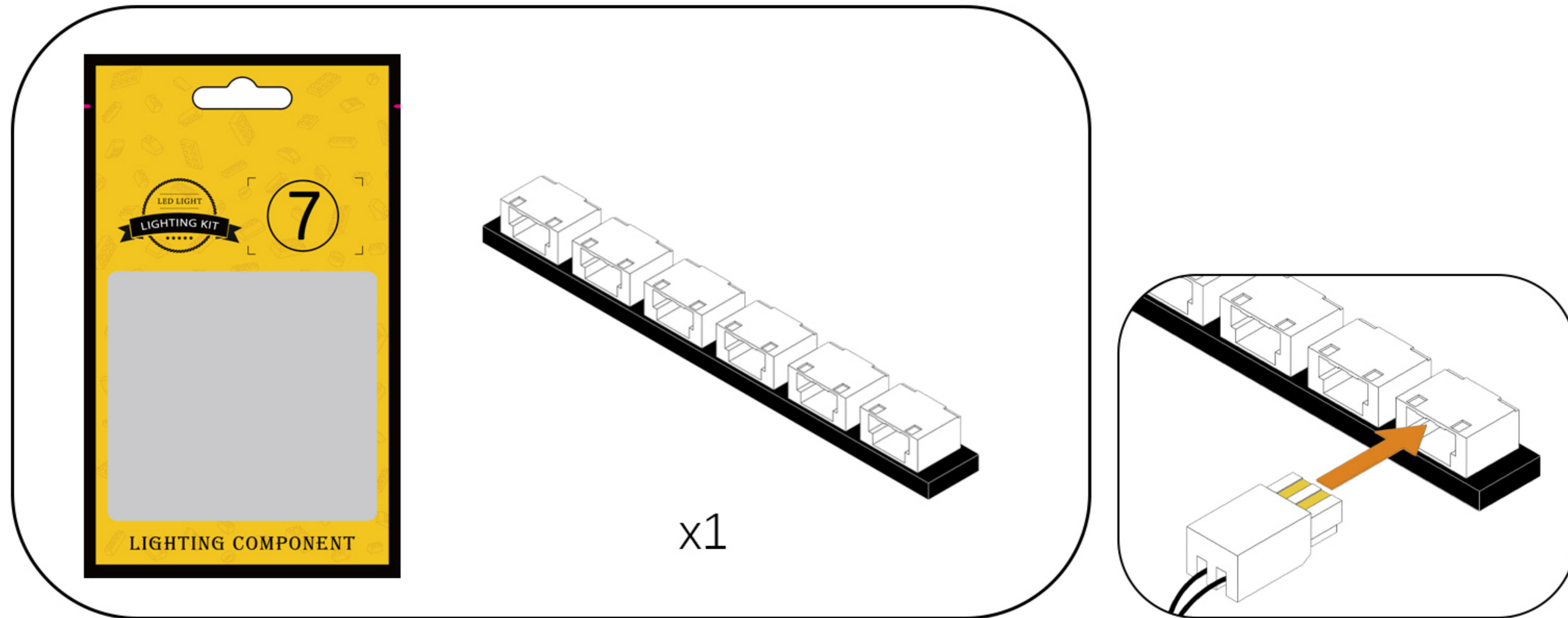

3

EN: Connect the touch-controlled dimming module to a portable power bank. (Power source not included; this guide uses a portable power bank. See the image below for other power options.)

DE: Schließen Sie das berührungsgesteuerte Dimmmodul an eine tragbare Powerbank an. (Stromquelle nicht im Lieferumfang enthalten; in dieser Anleitung wird eine tragbare Powerbank verwendet. Weitere Stromversorgungsoptionen finden Sie in der Abbildung unten.)

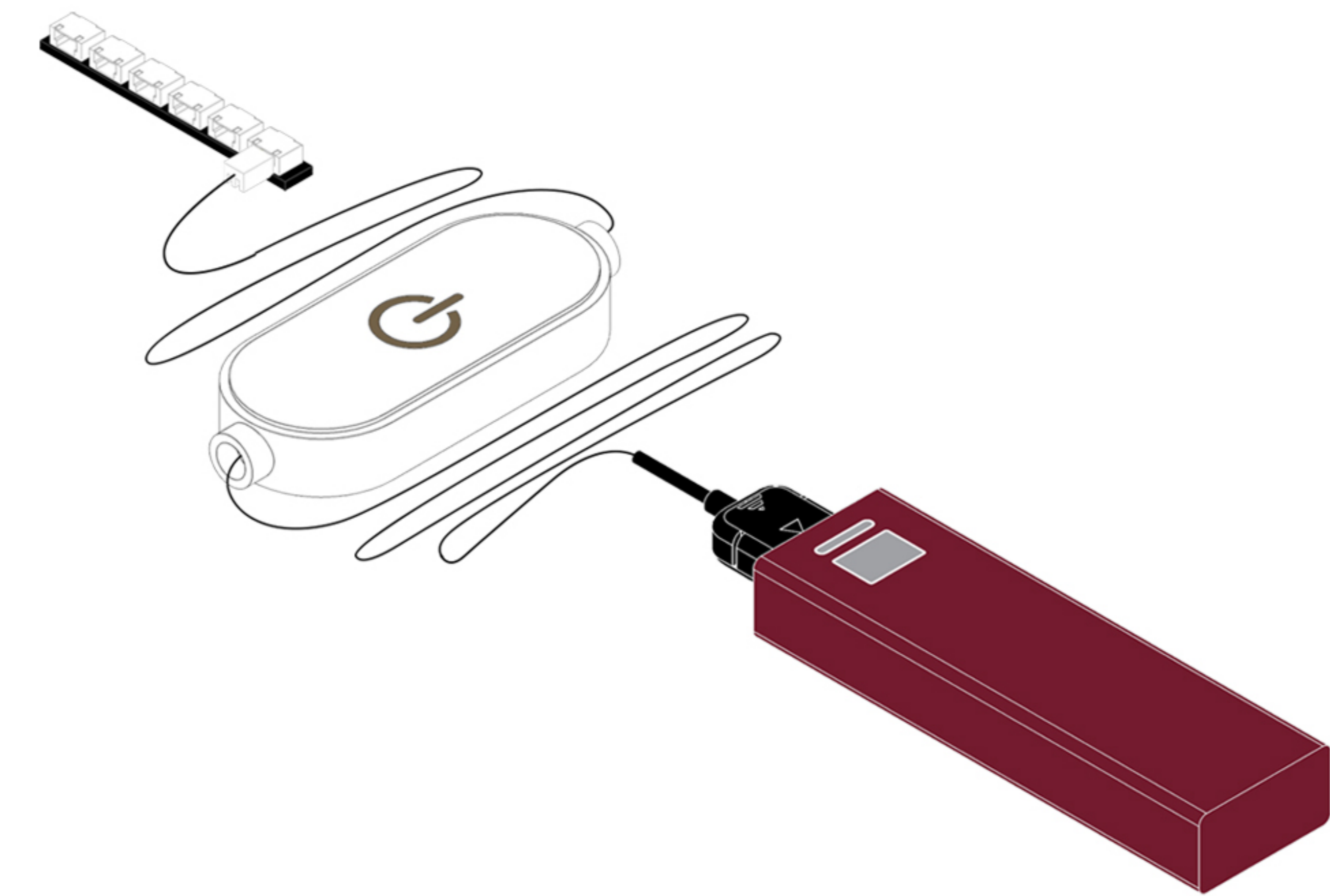

### USB Connectors to Connect Devices

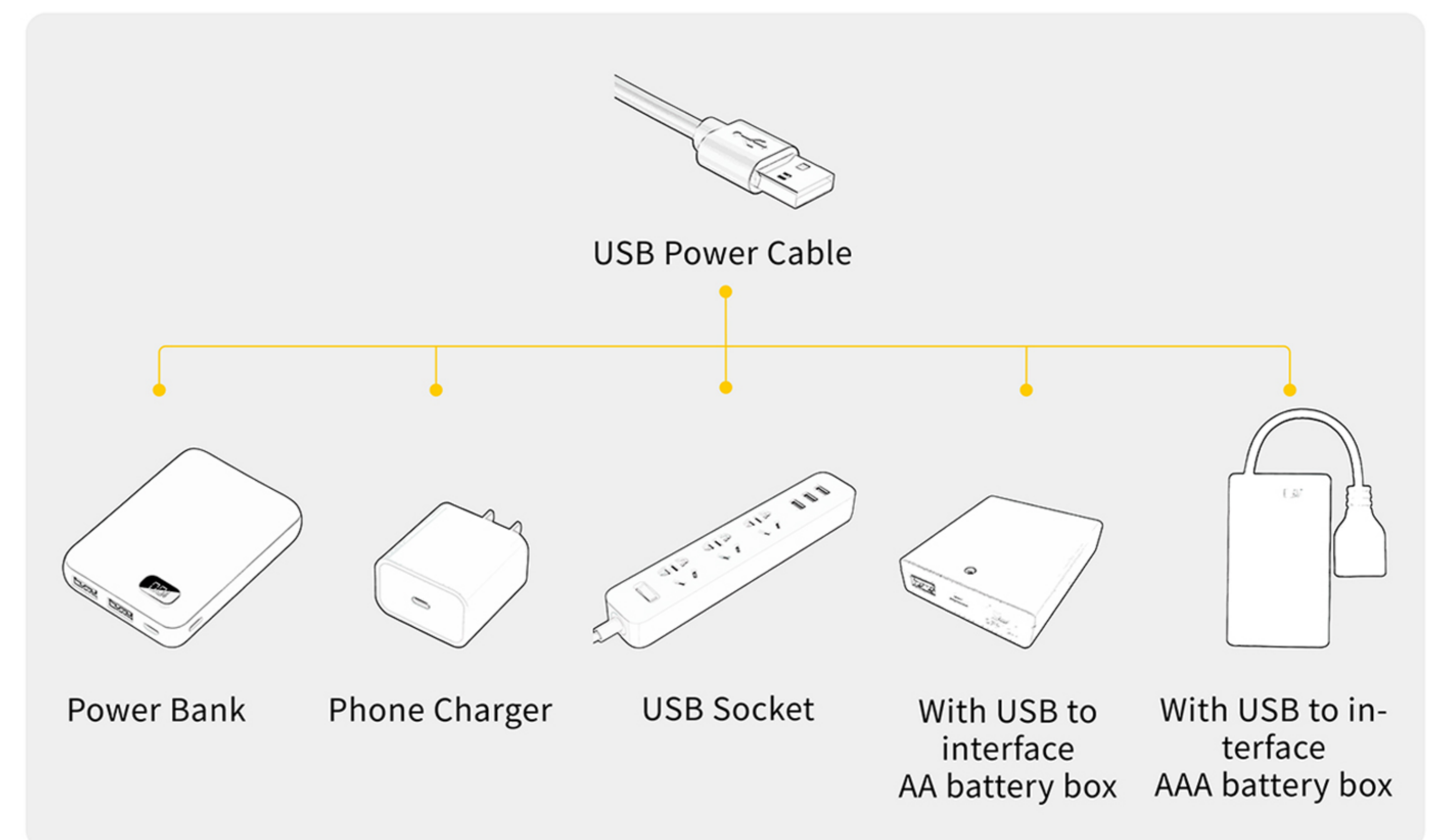

4

**EN:** Remove the COB light strip from Bag 1 and connect it to the expansion board. Turn on the power and test the dimming module by touching it with your hand to check if the COB light strip is working properly. If you notice any abnormalities, please contact us immediately.

**DE:** Nehmen Sie den COB-Lichtstreifen aus Beutel 1 und schließen Sie ihn an die Erweiterungskarte an. Schalten Sie das Gerät ein und testen Sie das Dimmmodul, indem Sie es mit der Hand berühren, um zu überprüfen, ob der COB-Lichtstreifen ordnungsgemäß funktioniert. Sollten Sie Unregelmäßigkeiten feststellen, kontaktieren Sie uns bitte umgehend.

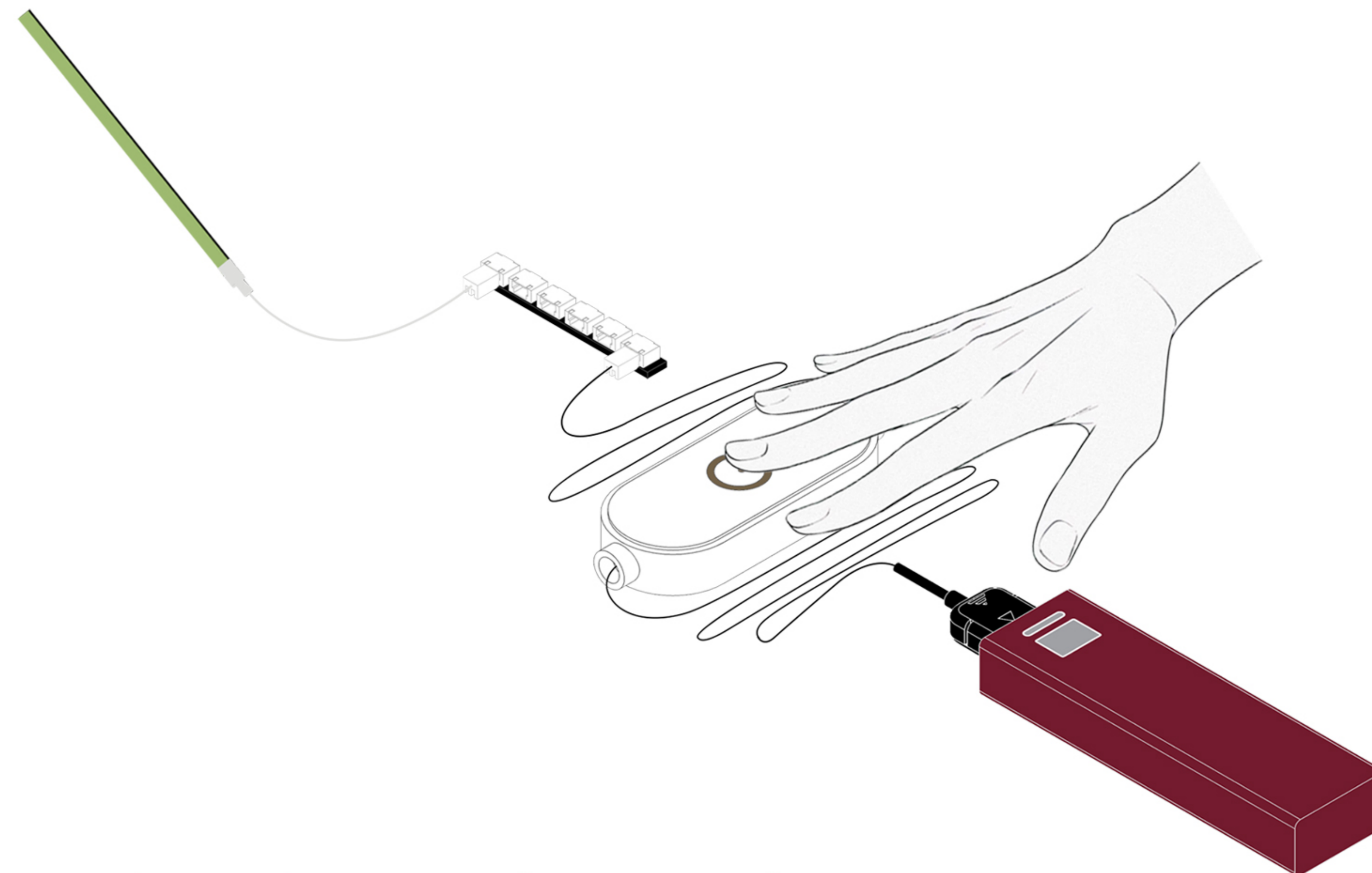
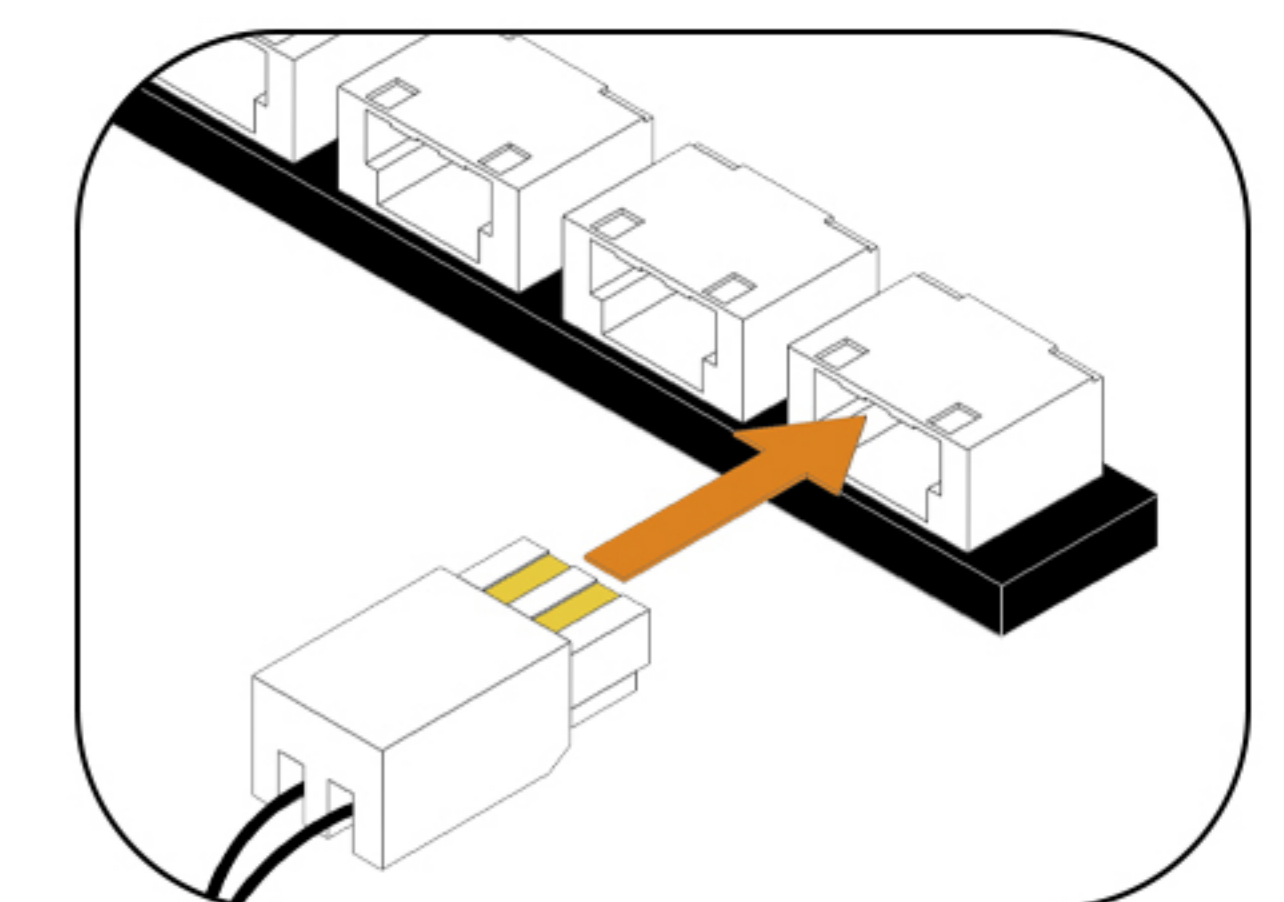
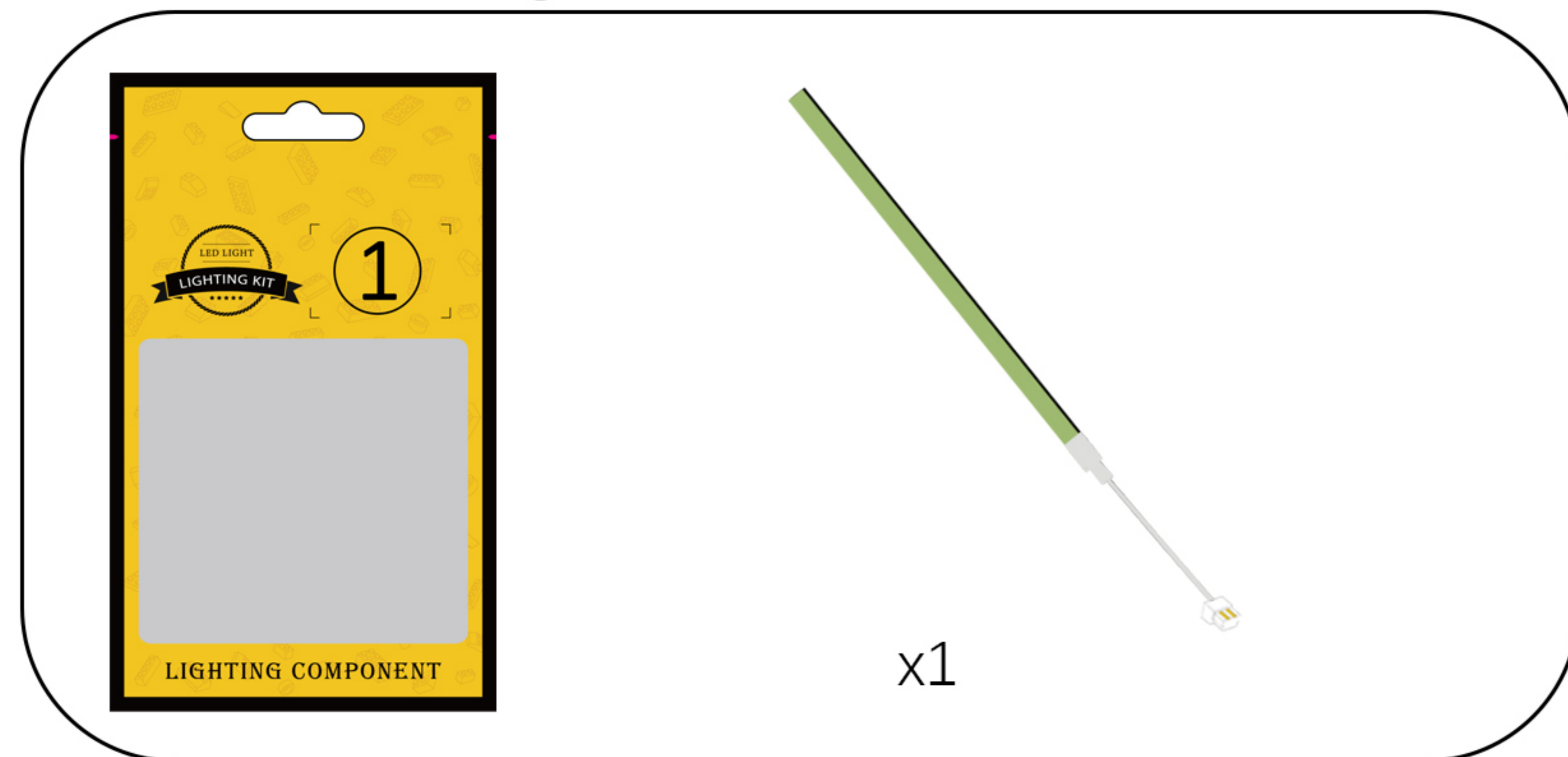

After confirming that there are no abnormalities, temporarily return each part to its original bag.

## Step 2-Mounting.

1

EN: Take out the building block model.

DE: Nimm das Bauklotzmodell heraus.



2

EN: Split as shown in the figure.

DE: Wie in der Abbildung gezeigt, teilen Sie es auf.

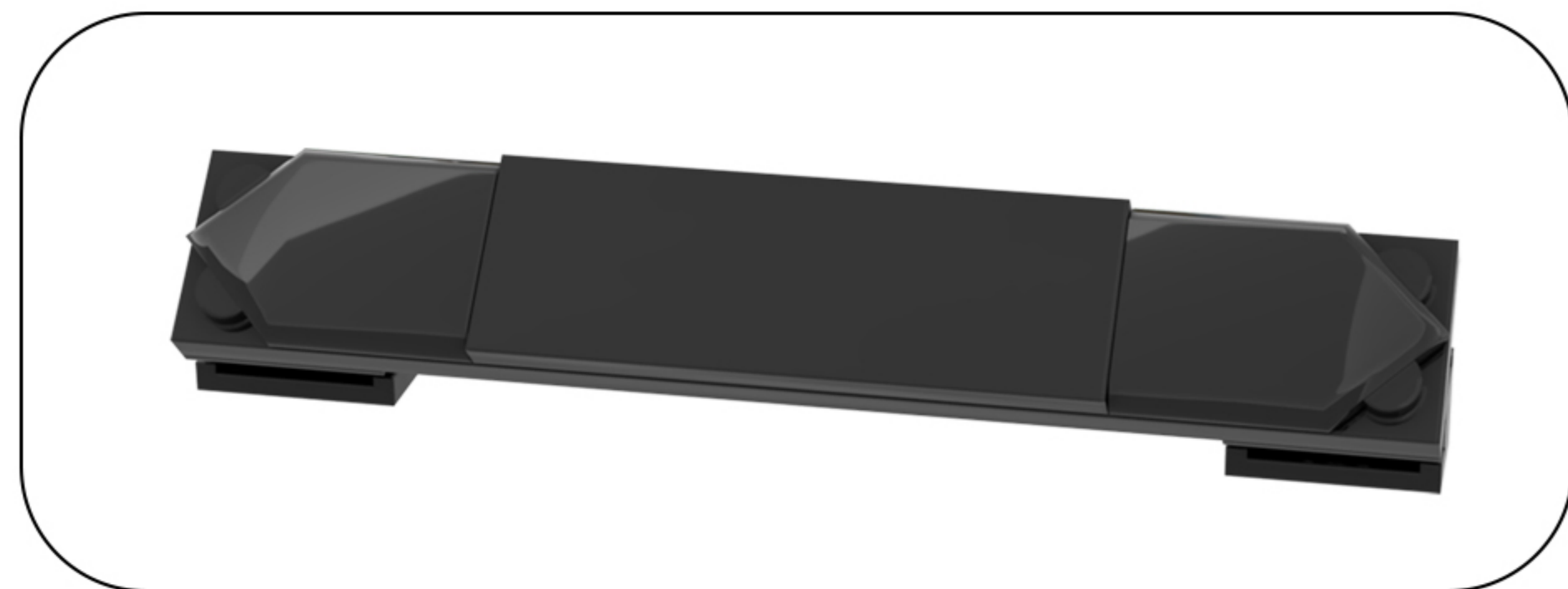
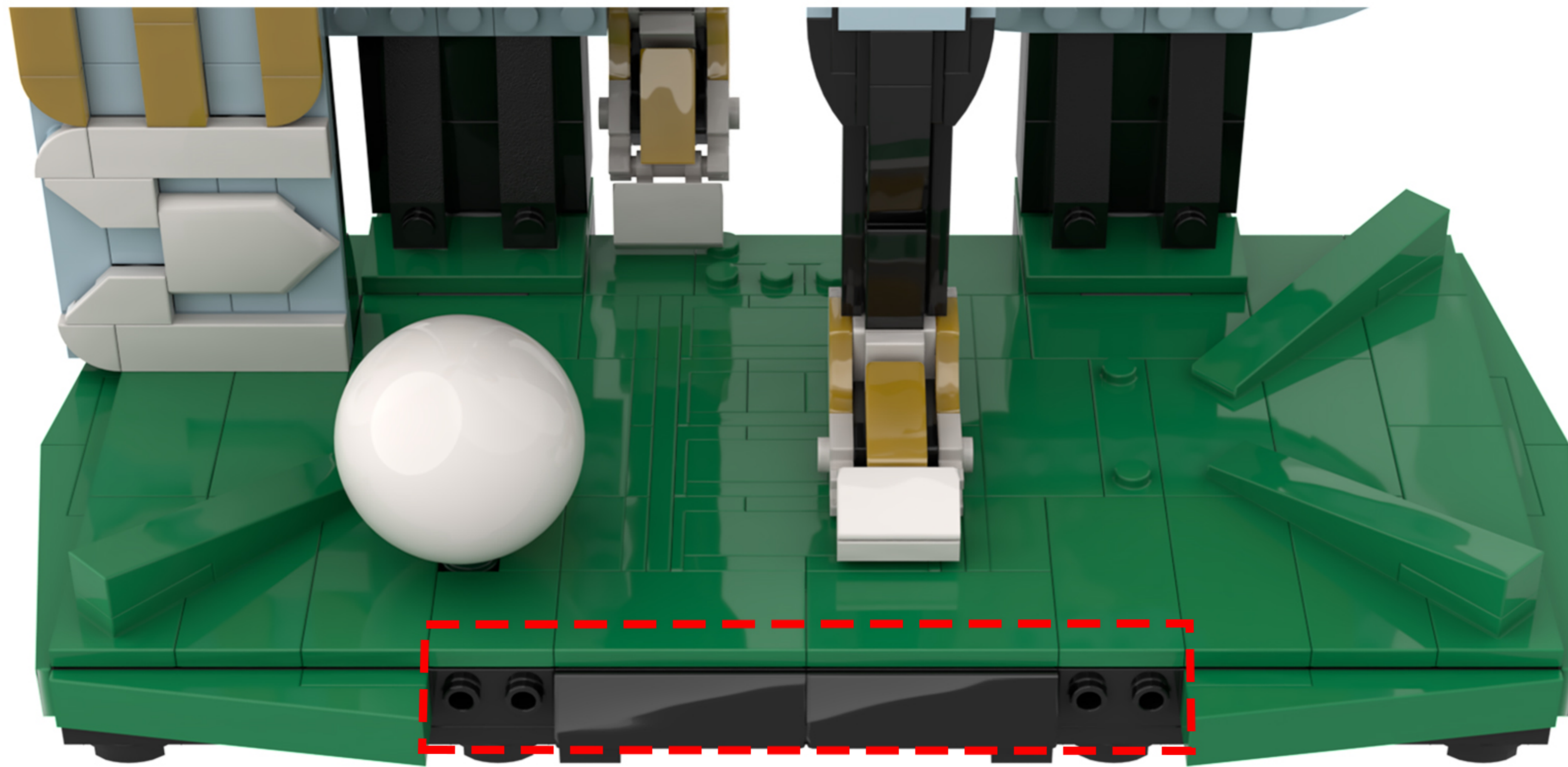

3

EN: Remove the COB light strip from Bag 1 and remove the protective cover from the COB light strip.

DE: Nehmen Sie den COB-Lichtstreifen aus Beutel 1 und entfernen Sie die Schutzfolie vom COB-Lichtstreifen.

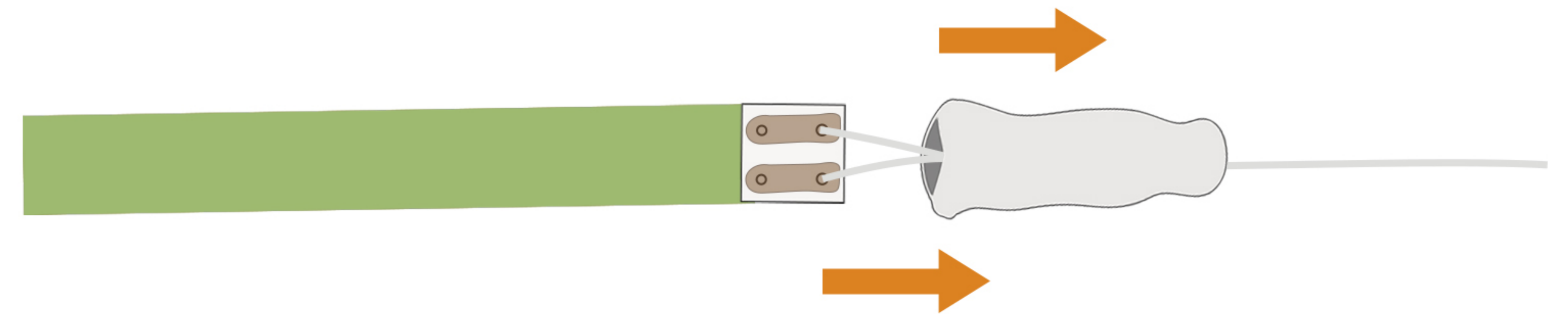
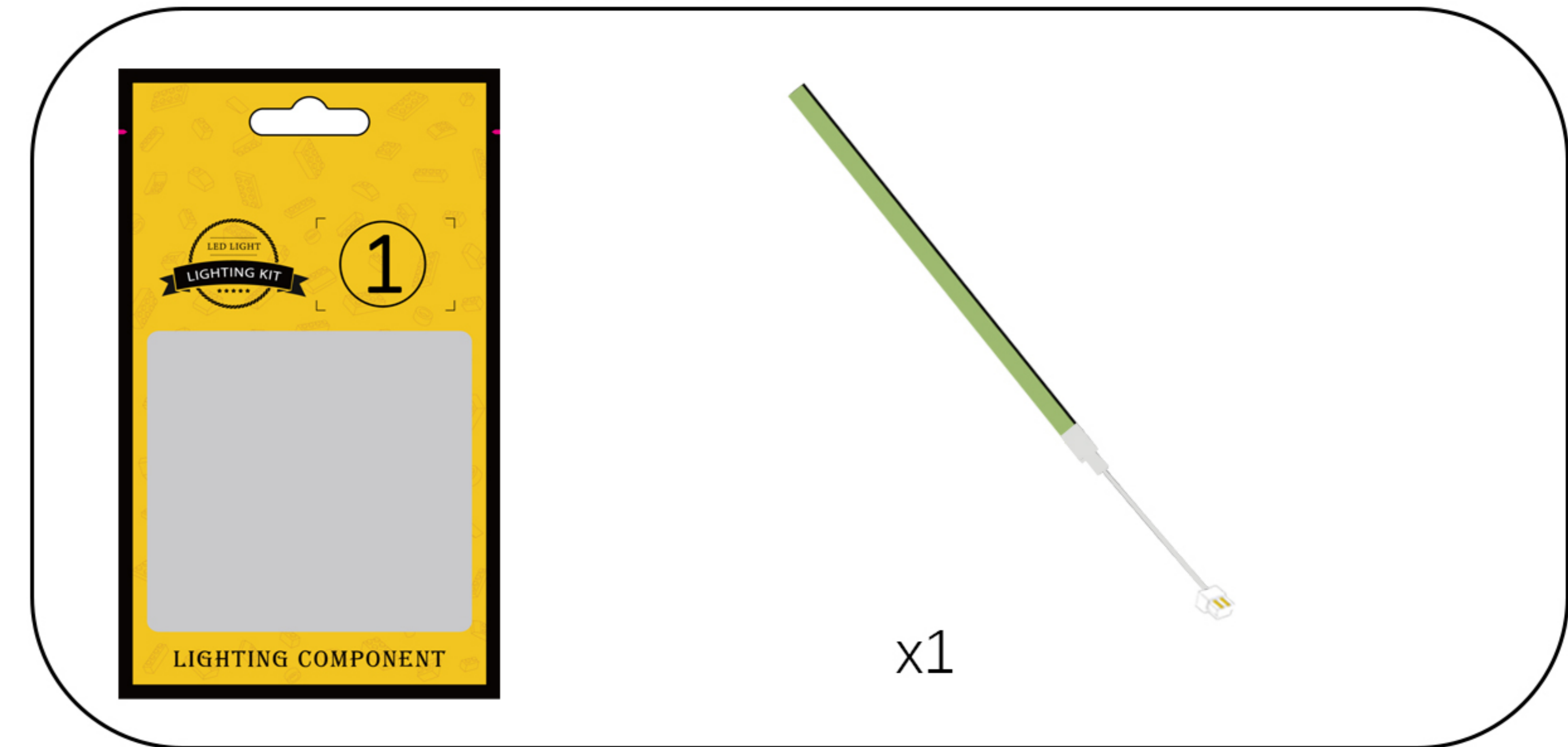

4

EN: Peel off the adhesive backing from the COB light strip and attach it to the location shown in the illustration.

DE: Ziehen Sie die Schutzfolie vom COB-Lichtband ab und bringen Sie es an der in der Abbildung gezeigten Stelle an.

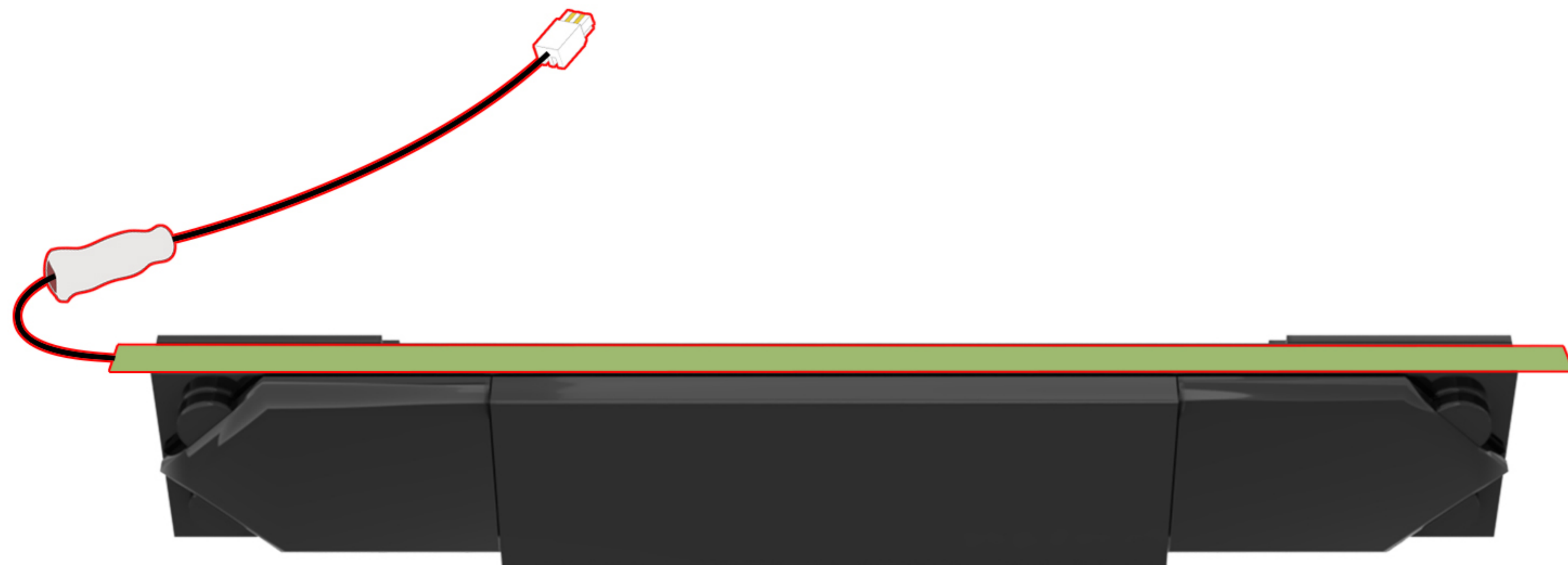

5

EN: Turn the model over, then position the light strings as shown in the figure.

DE: Drehen Sie das Modell um und positionieren Sie die Lichterketten wie in der Abbildung gezeigt.

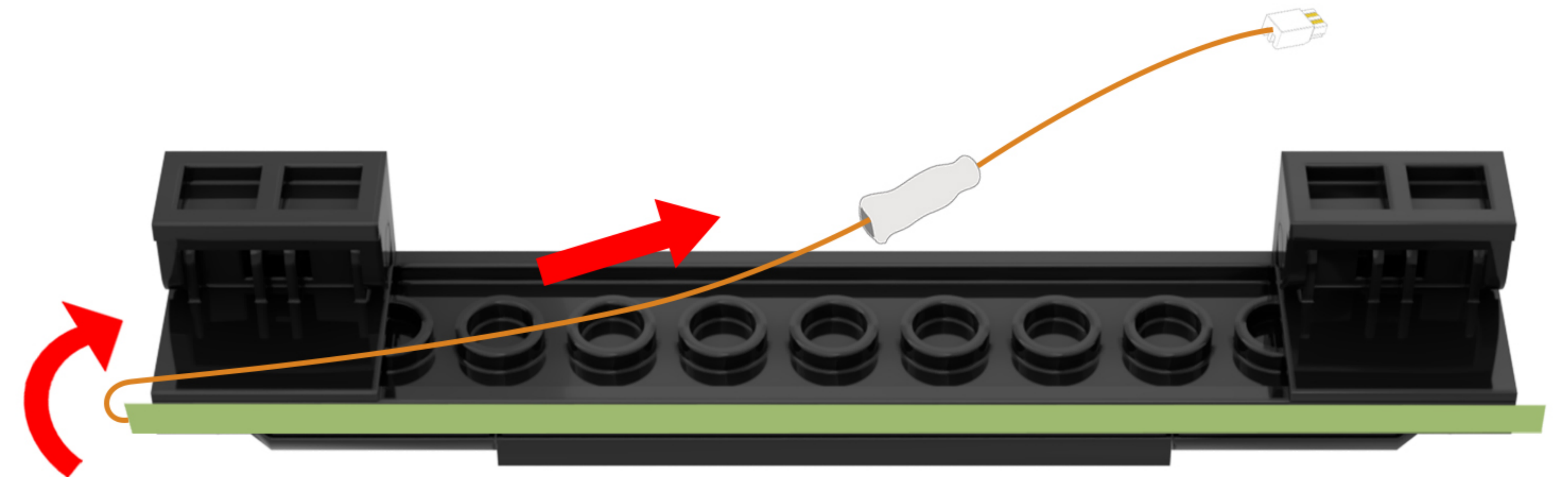
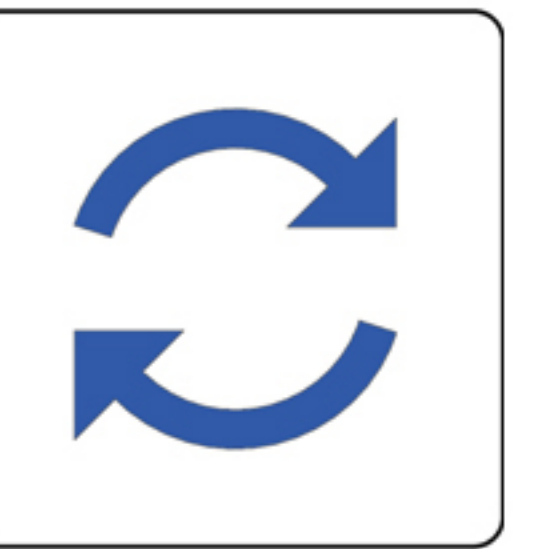

6

EN: Restore the building blocks.

DE: Stellen Sie die Bausteine wieder her.

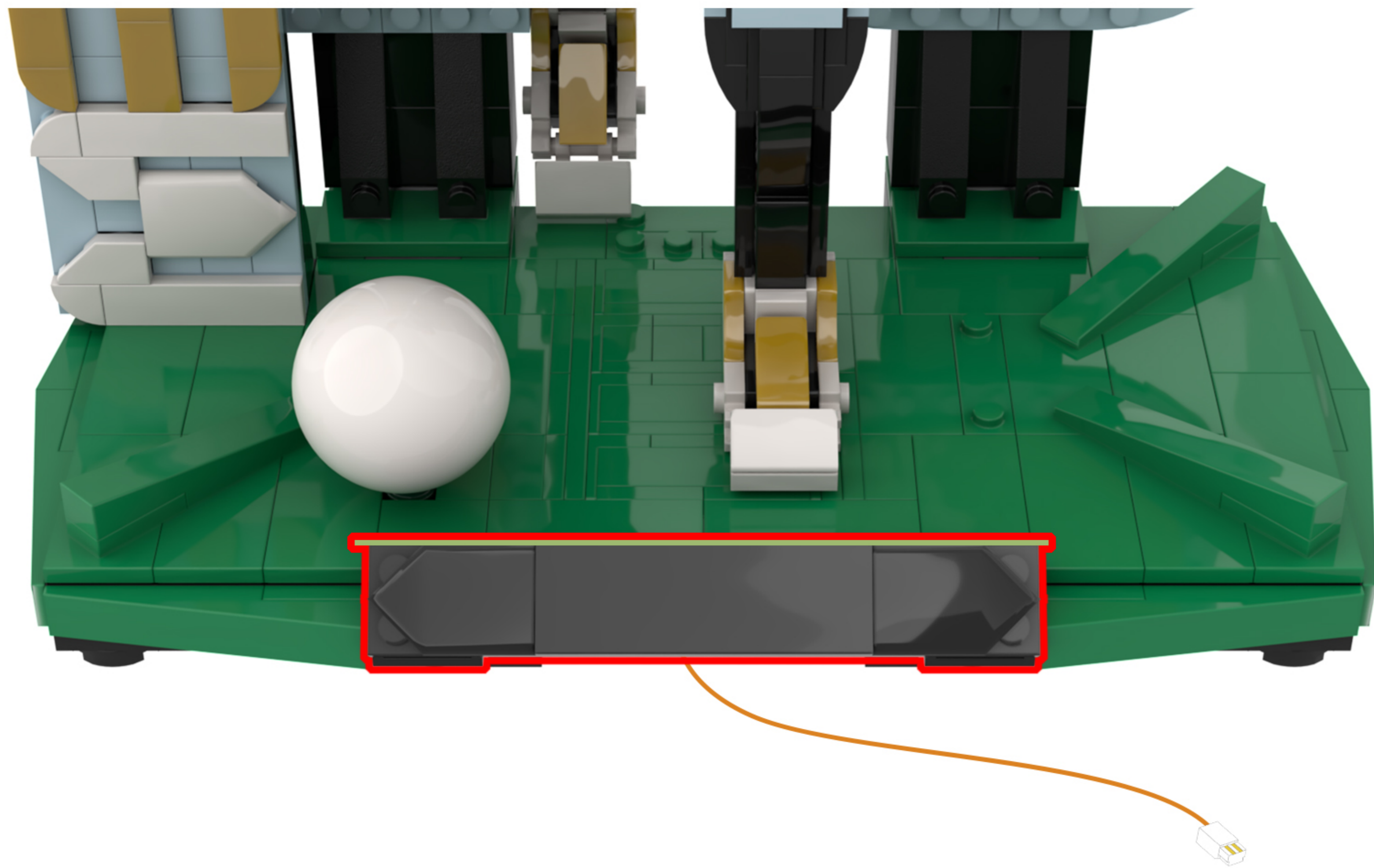

7

EN: Split as shown in the figure.

DE: Wie in der Abbildung gezeigt, teilen Sie es auf.

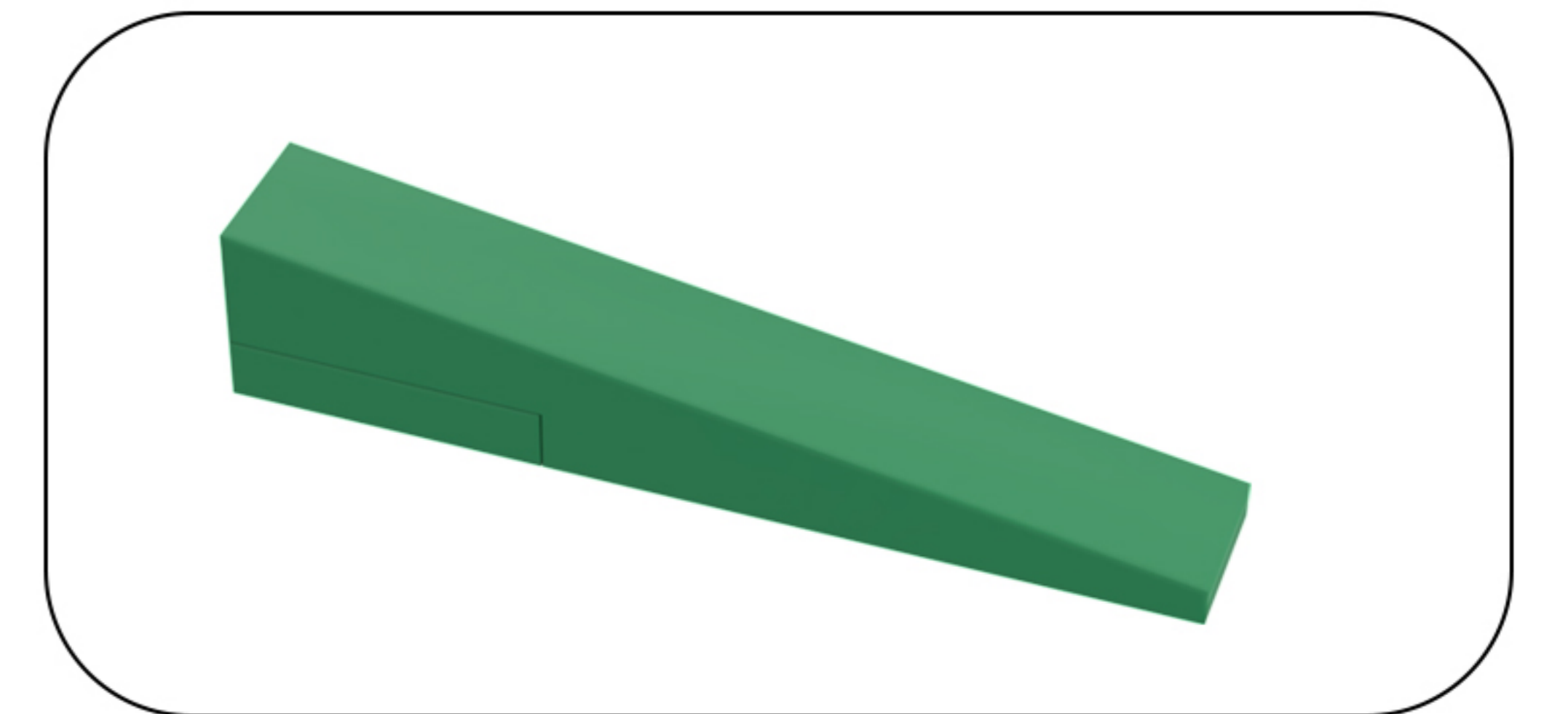
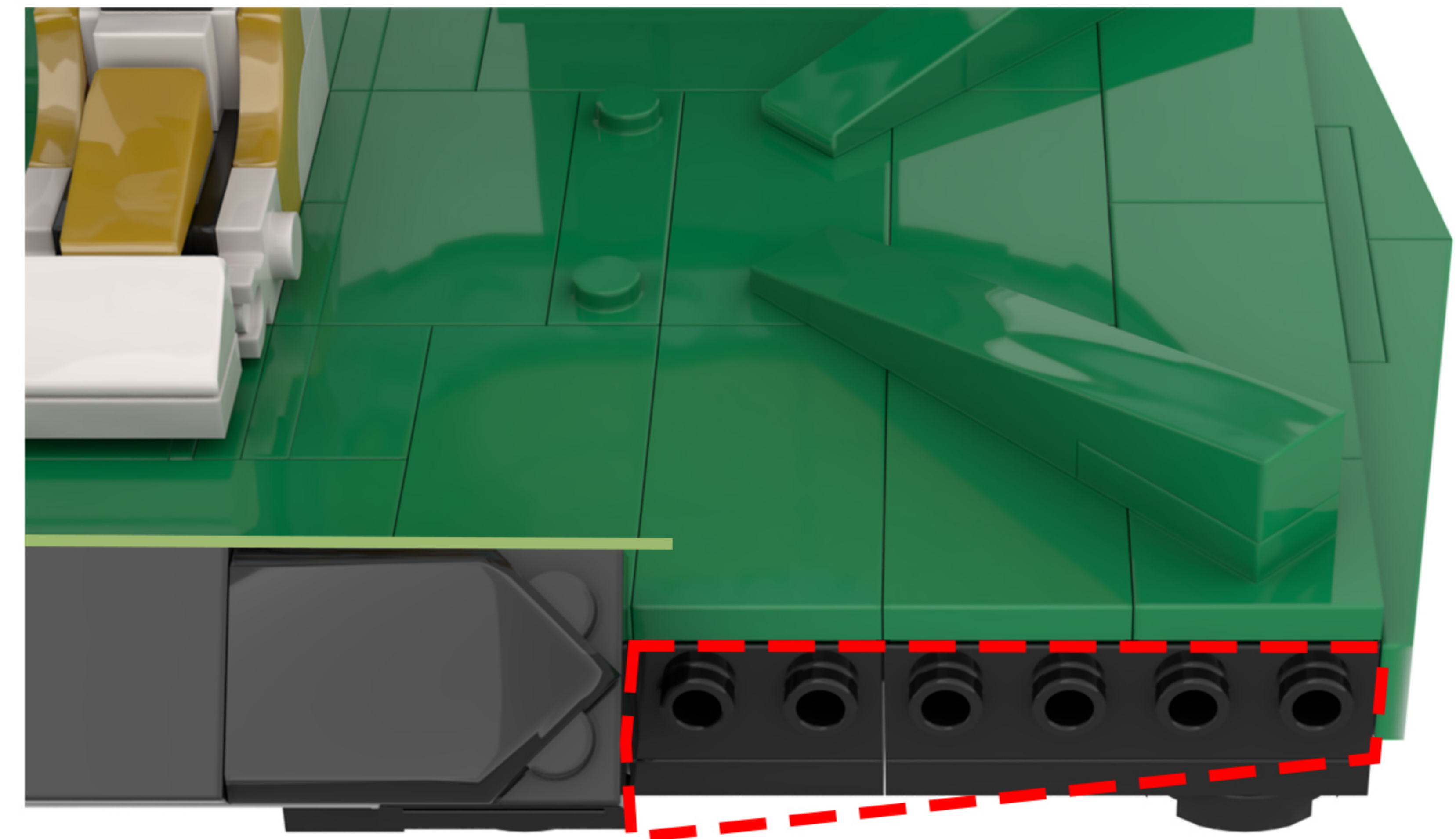

8

EN: Take the following building blocks and light beads from Bag 2, and follow the instructions step by step.

DE: Nimm die folgenden Bausteine und Leuchtperlen aus Beutel 2 und befolge die Anleitung Schritt für Schritt.

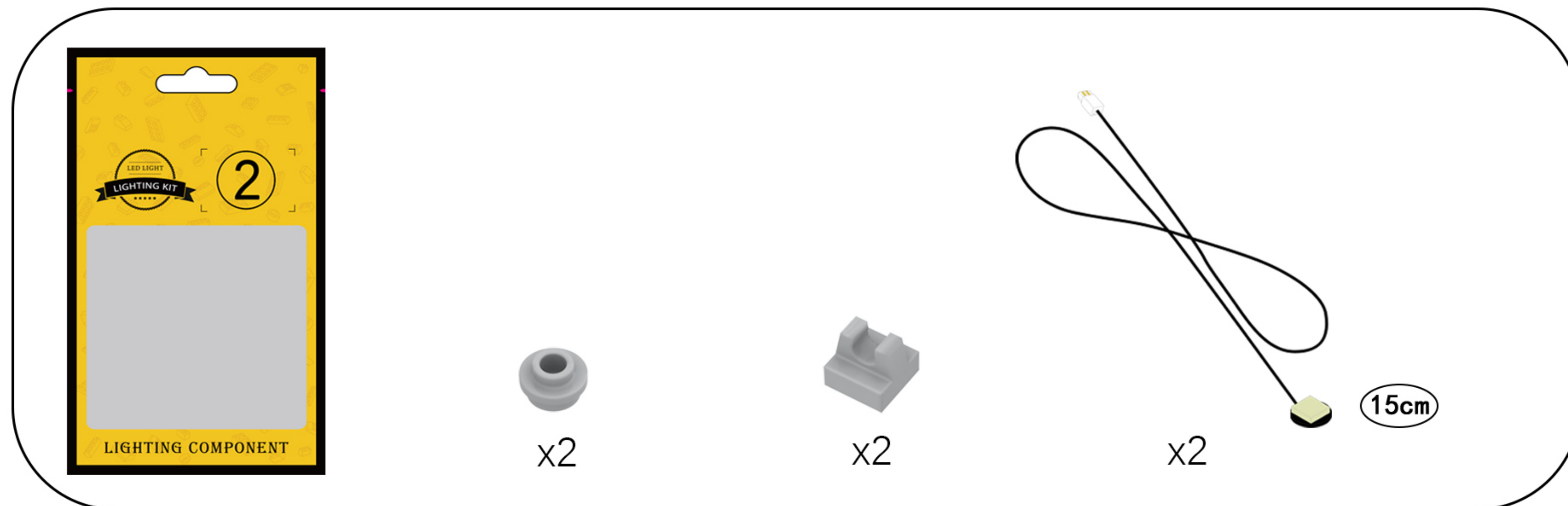

①. Thread the light bead onto the small round disc.

②. Pull the light cord so that the light-emitting surface of the light bead rests against the inside of the small circular plate.

③. Install the building blocks.

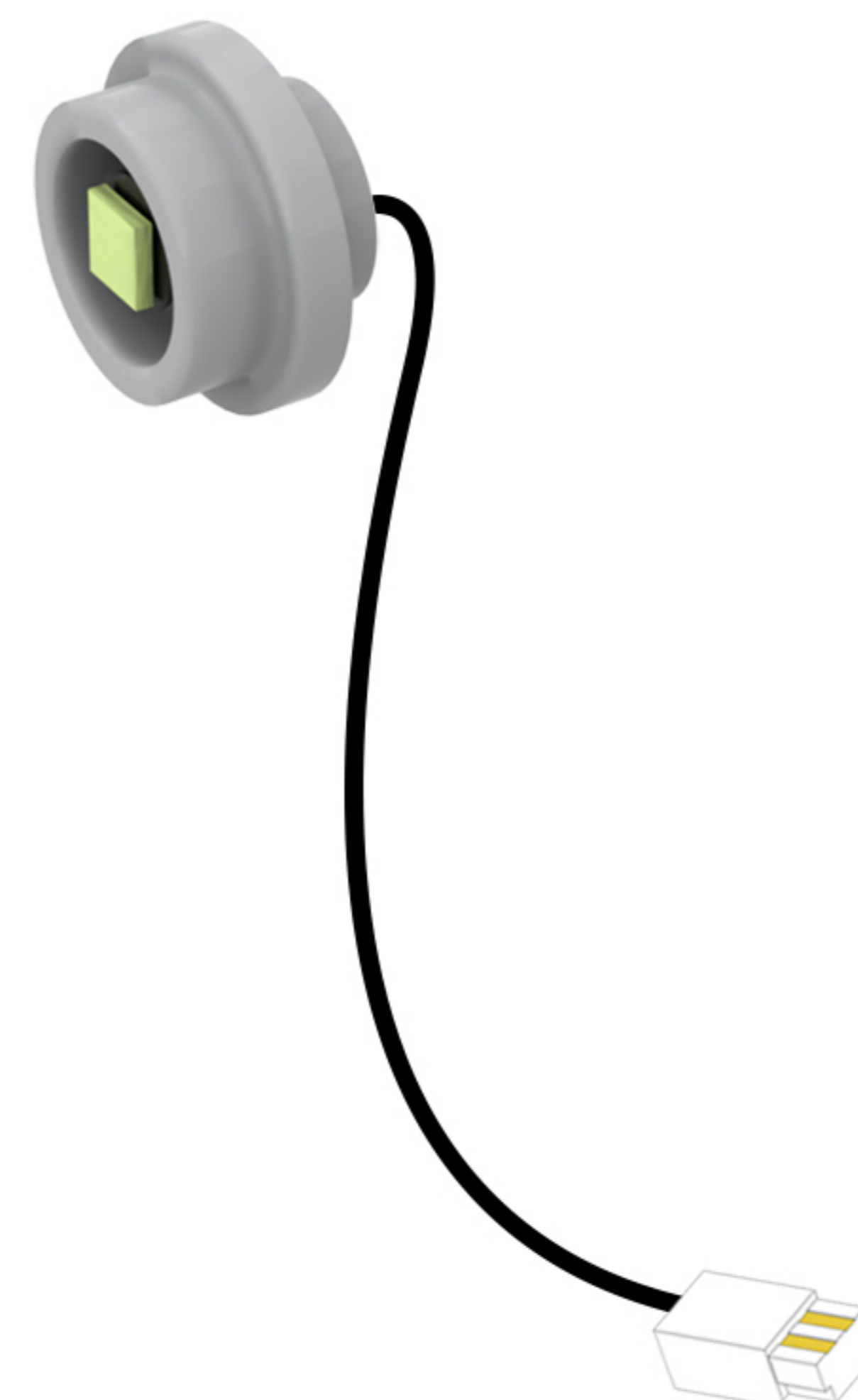
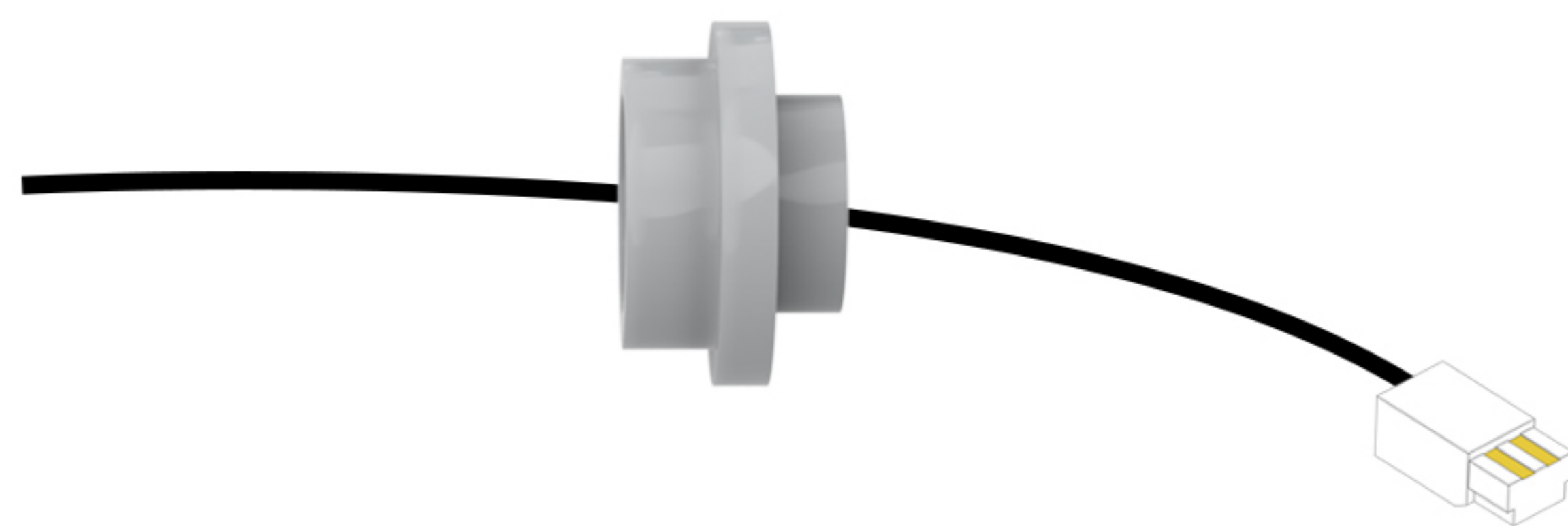

9

EN: Repeat the above steps to obtain two lamps.

DE: Wiederholen Sie die oben genannten Schritte, um zwei Lampen zu erhalten.

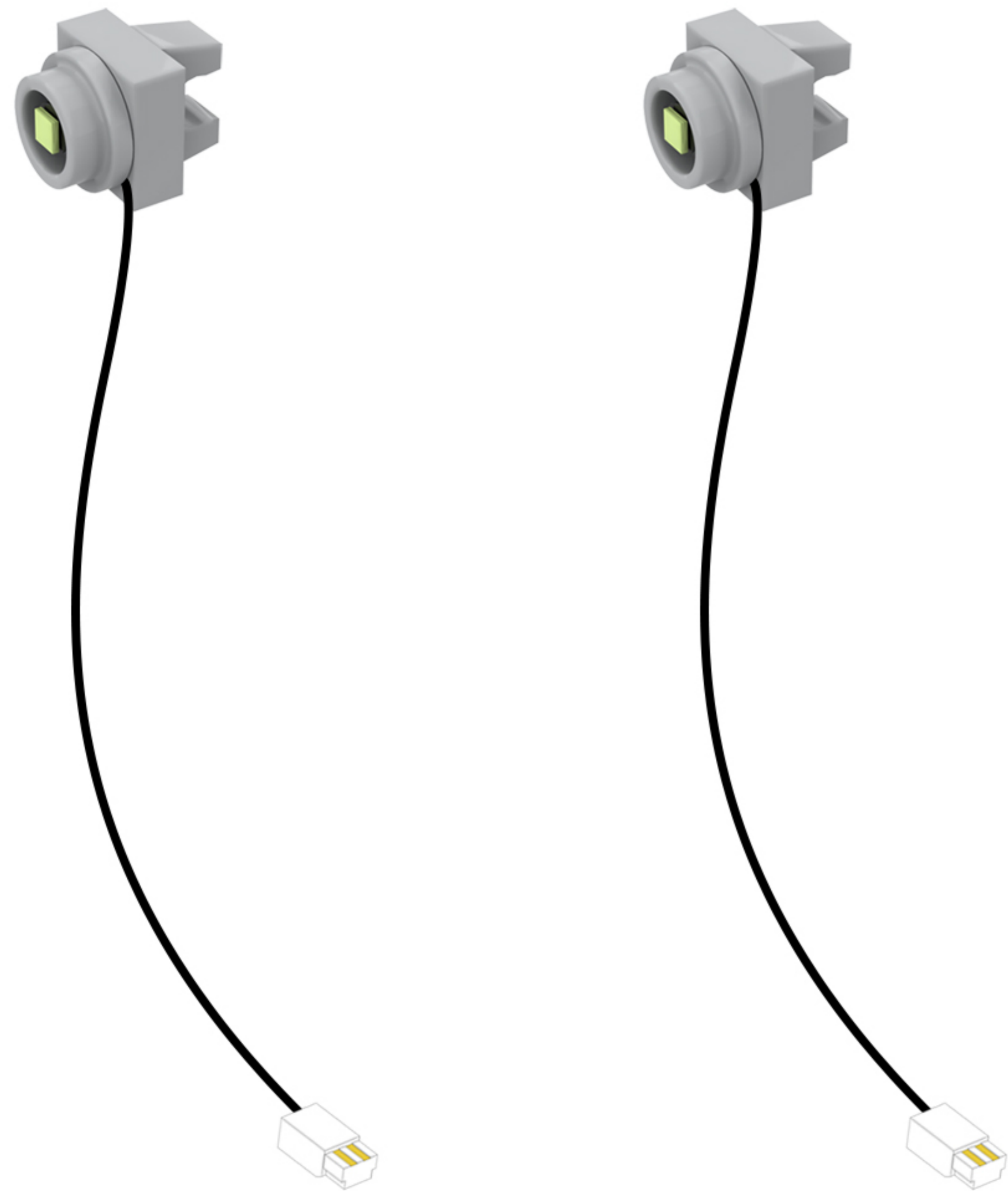

10

EN: Take the two building blocks from Bag 2 and attach them to the two light fixtures.

DE: Nimm die beiden Bausteine aus Beutel 2 und befestige sie an den beiden Leuchten.

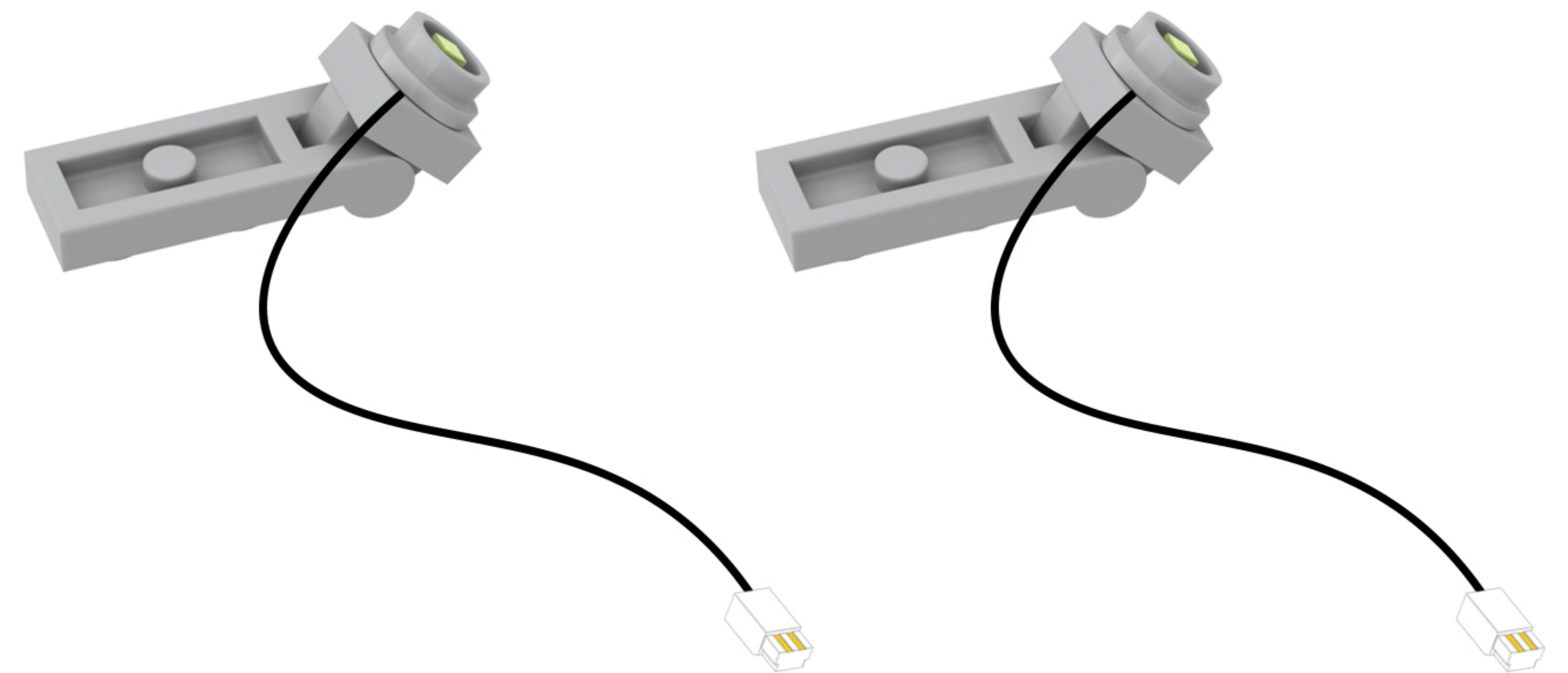
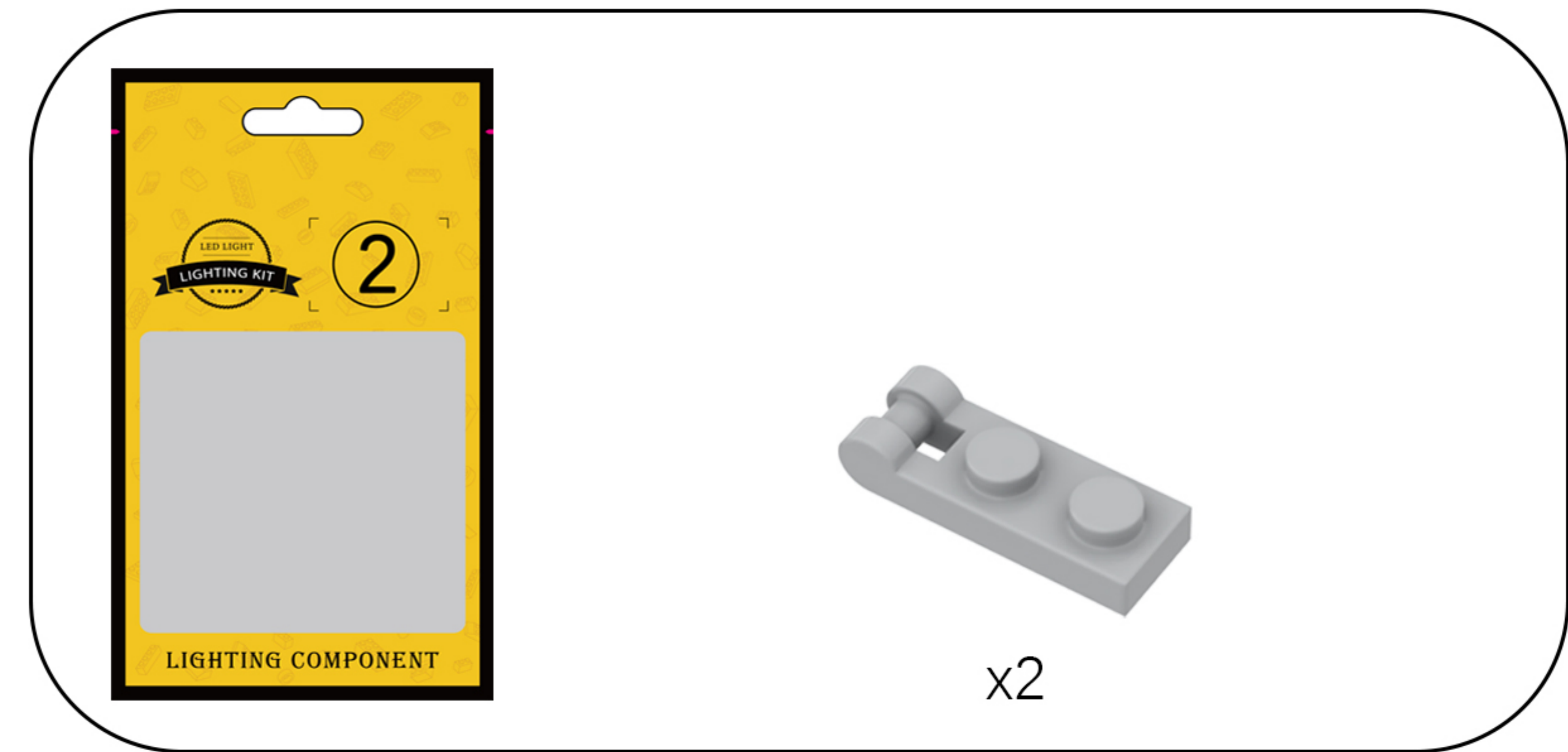

11

EN: Attach one of the lights to the building block.

DE: Befestige eine der Leuchten am Baustein.

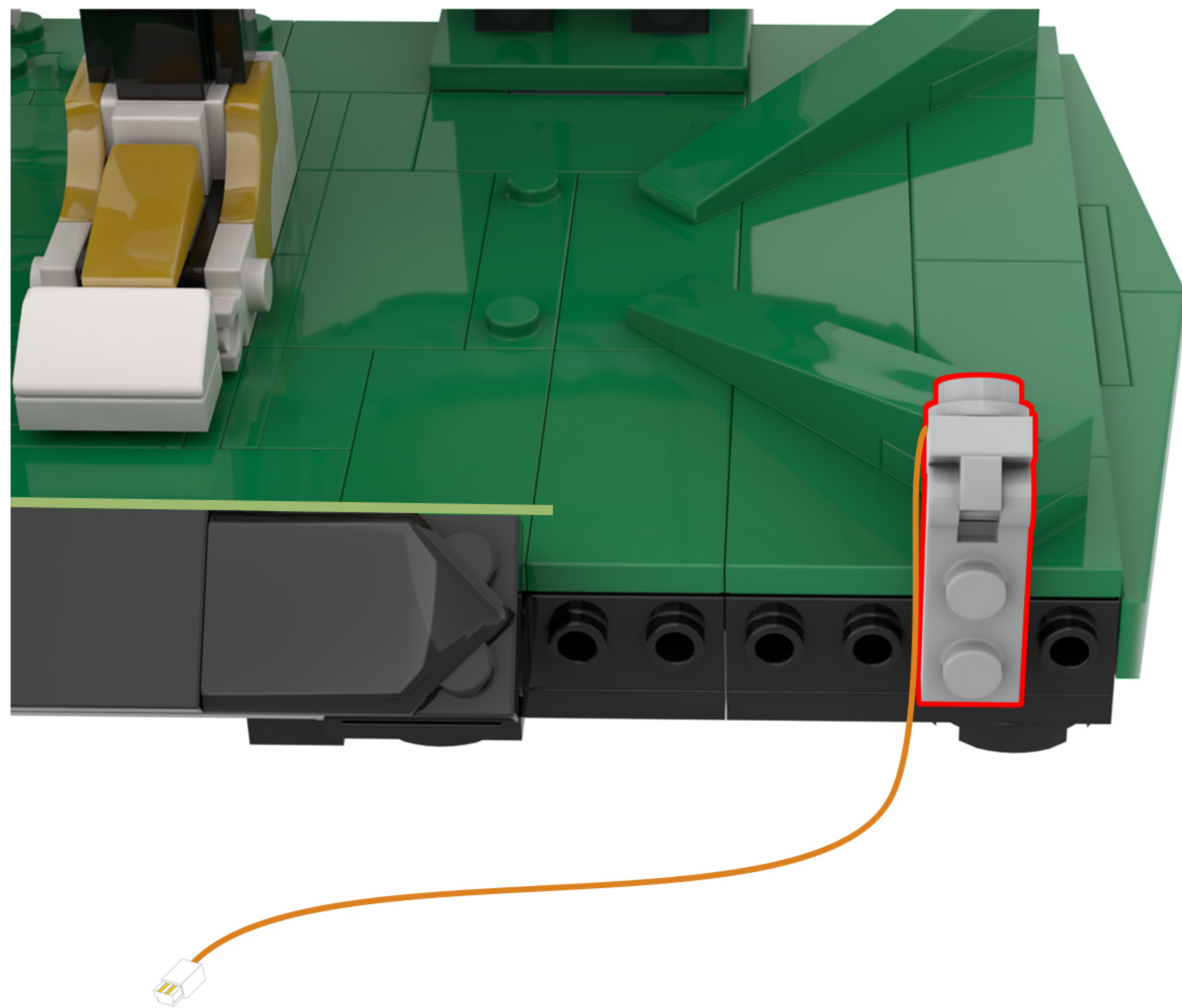

12

EN: Take the 2x2 and 2x4 base plates from Bag 2 and attach them to the building blocks, making sure to secure the light cord in place.

DE: Nimm die 2x2- und 2x4-Grundplatten aus Beutel 2 und befestige sie an den Bausteinen. Achte dabei darauf, das Lichtkabel sicher zu befestigen.

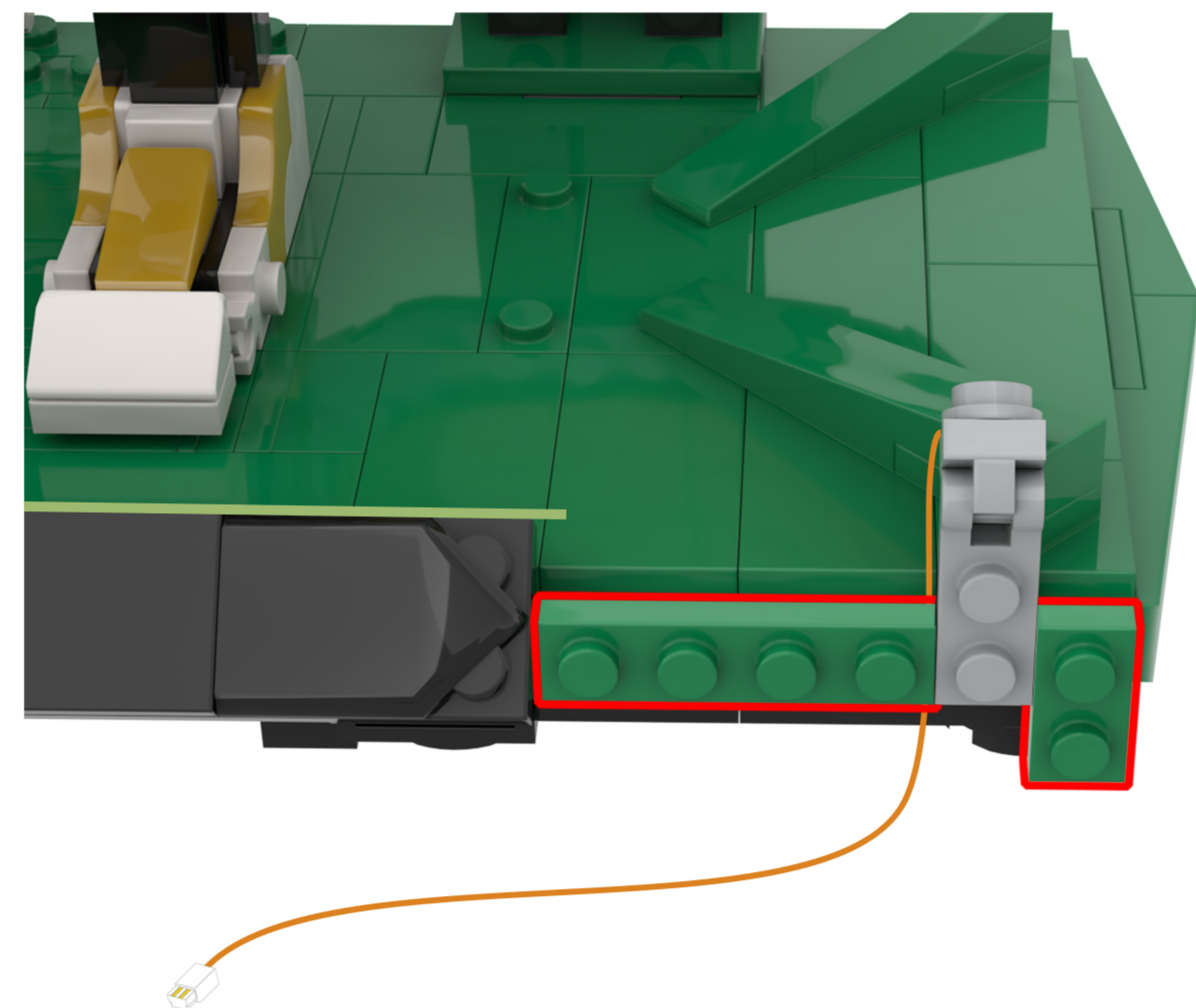
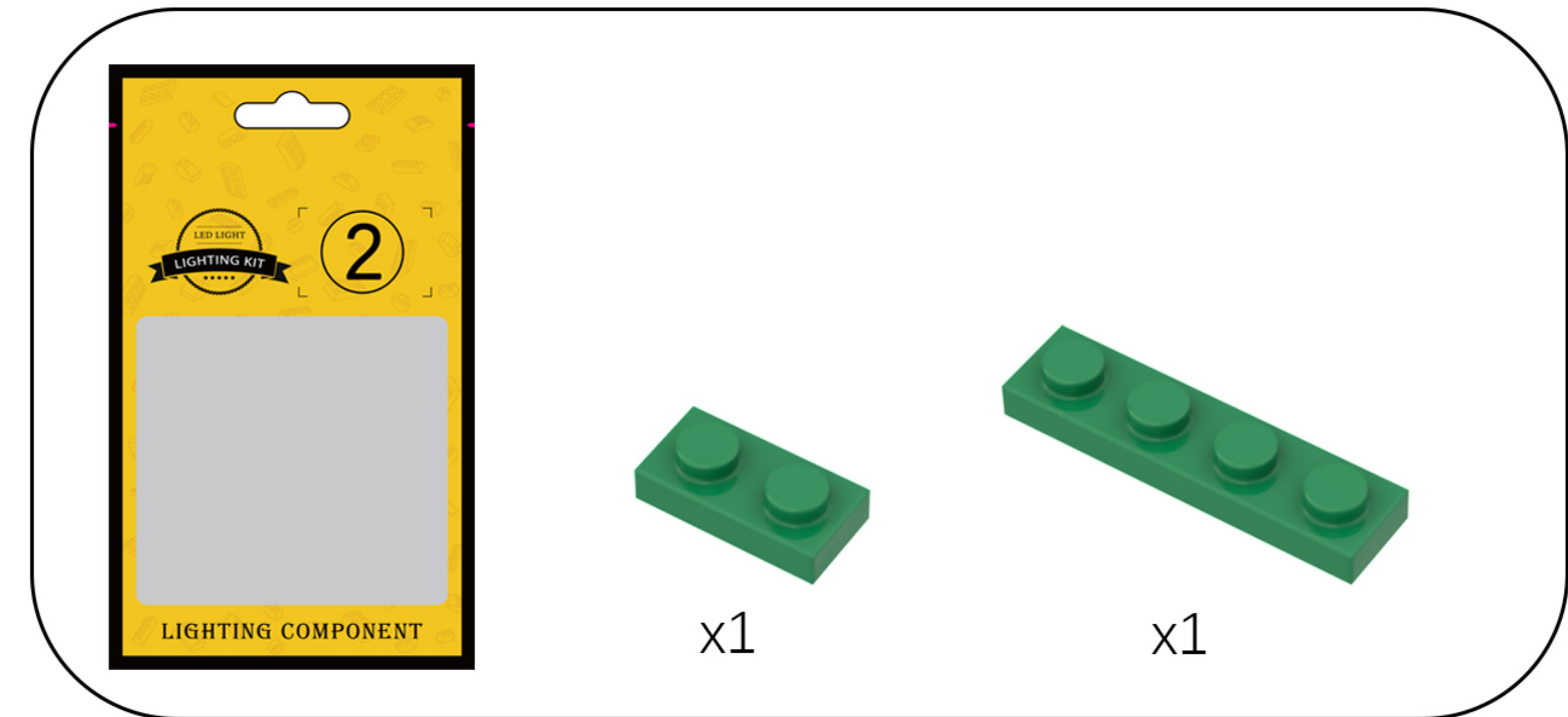

13

EN: Take out the disassembled building blocks and reassemble them.

DE: Nehmen Sie die zerlegten Bausteine heraus und setzen Sie sie wieder zusammen.

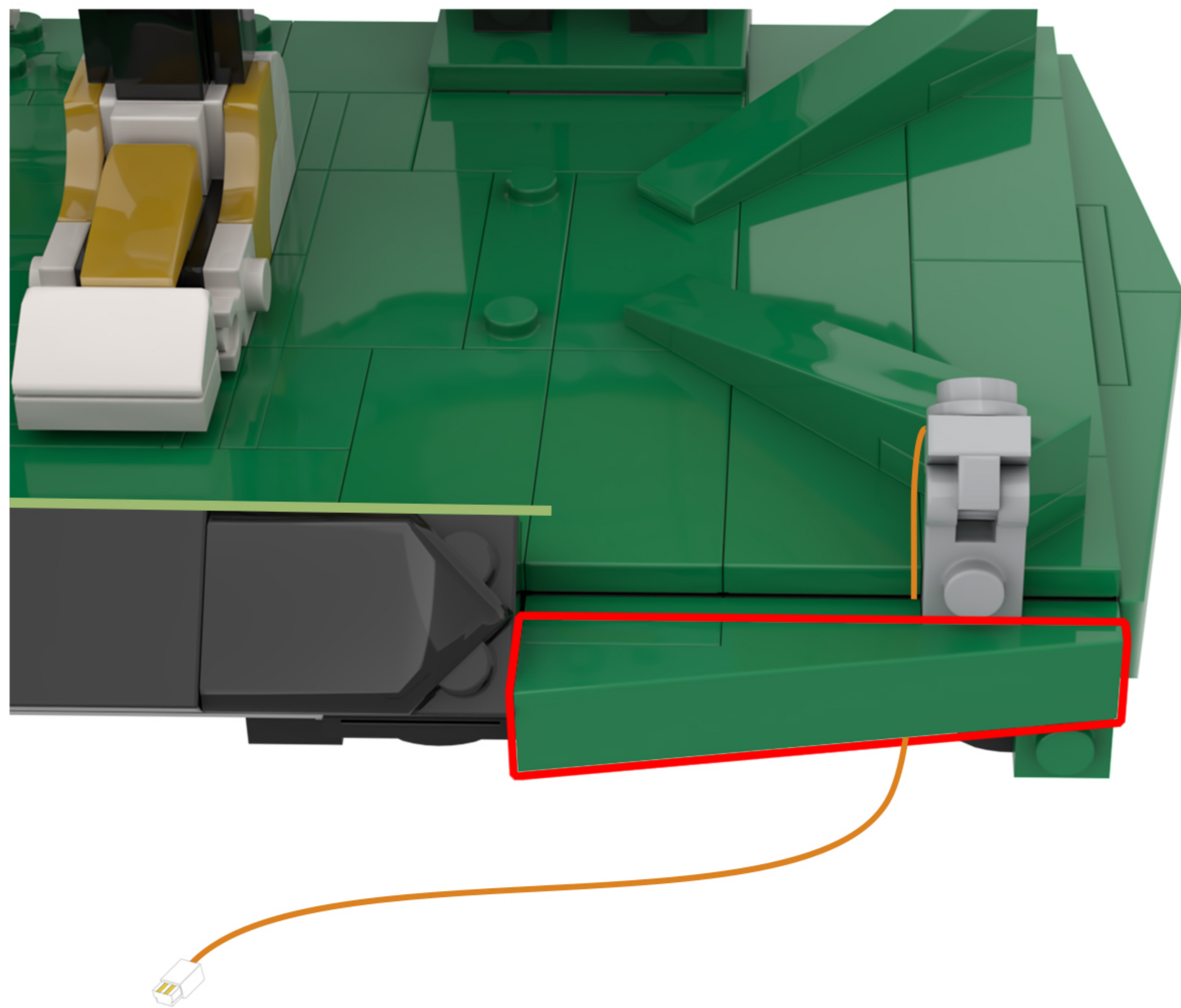
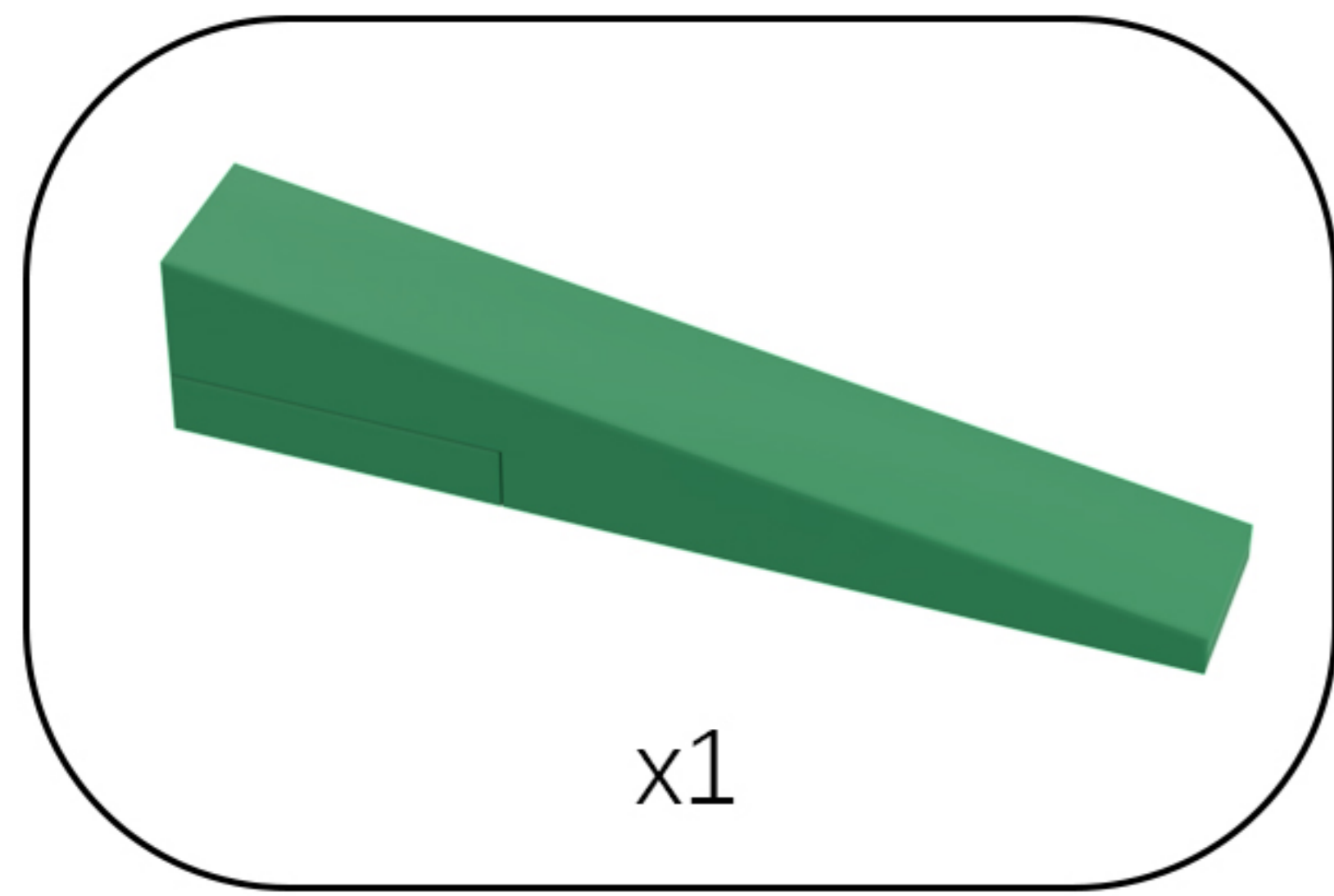

14

EN: Go to the other side of the model and disassemble it as shown in the figure.

DE: Gehen Sie auf die andere Seite des Modells und bauen Sie es wie in der Abbildung gezeigt auseinander.

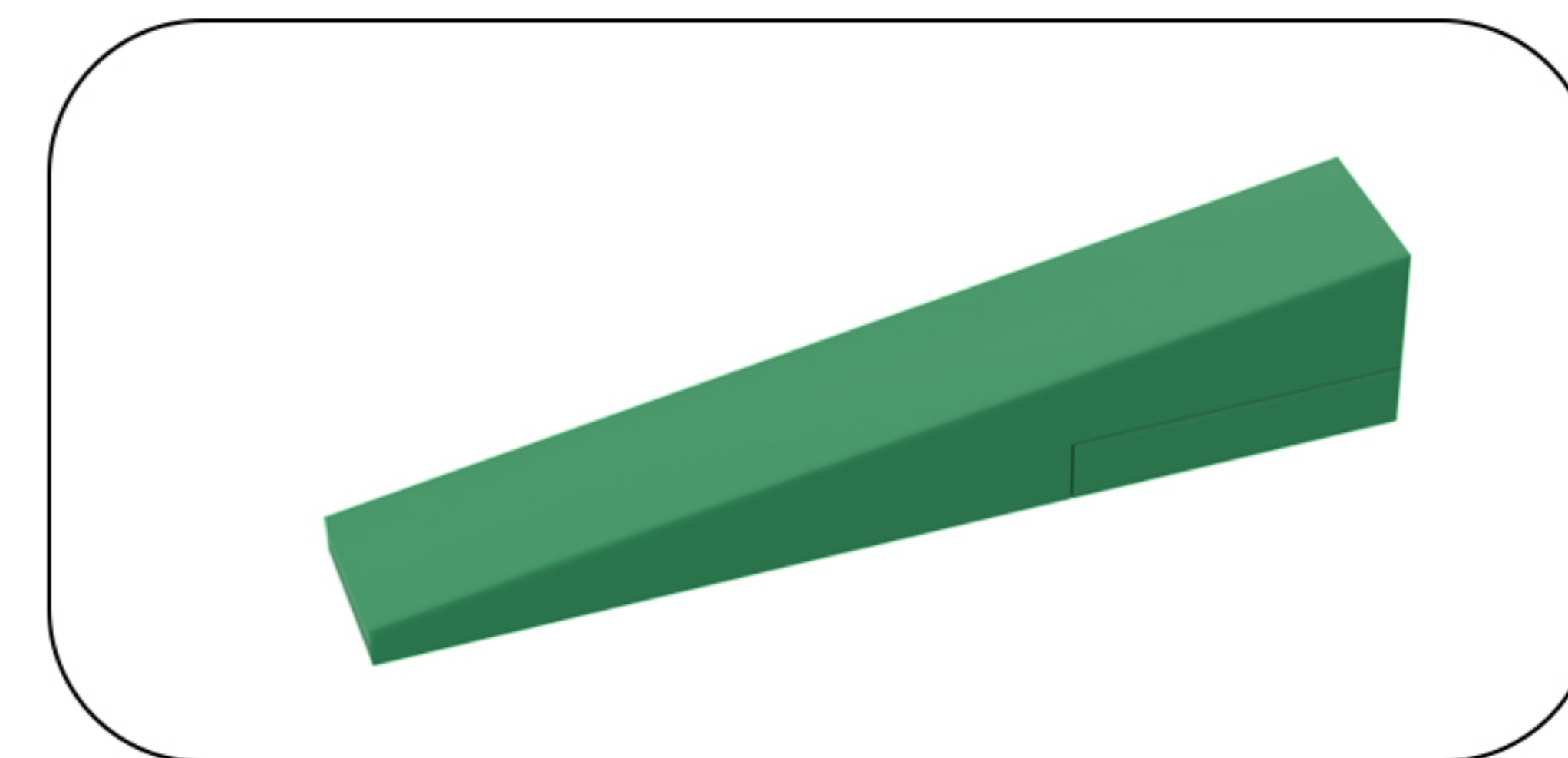
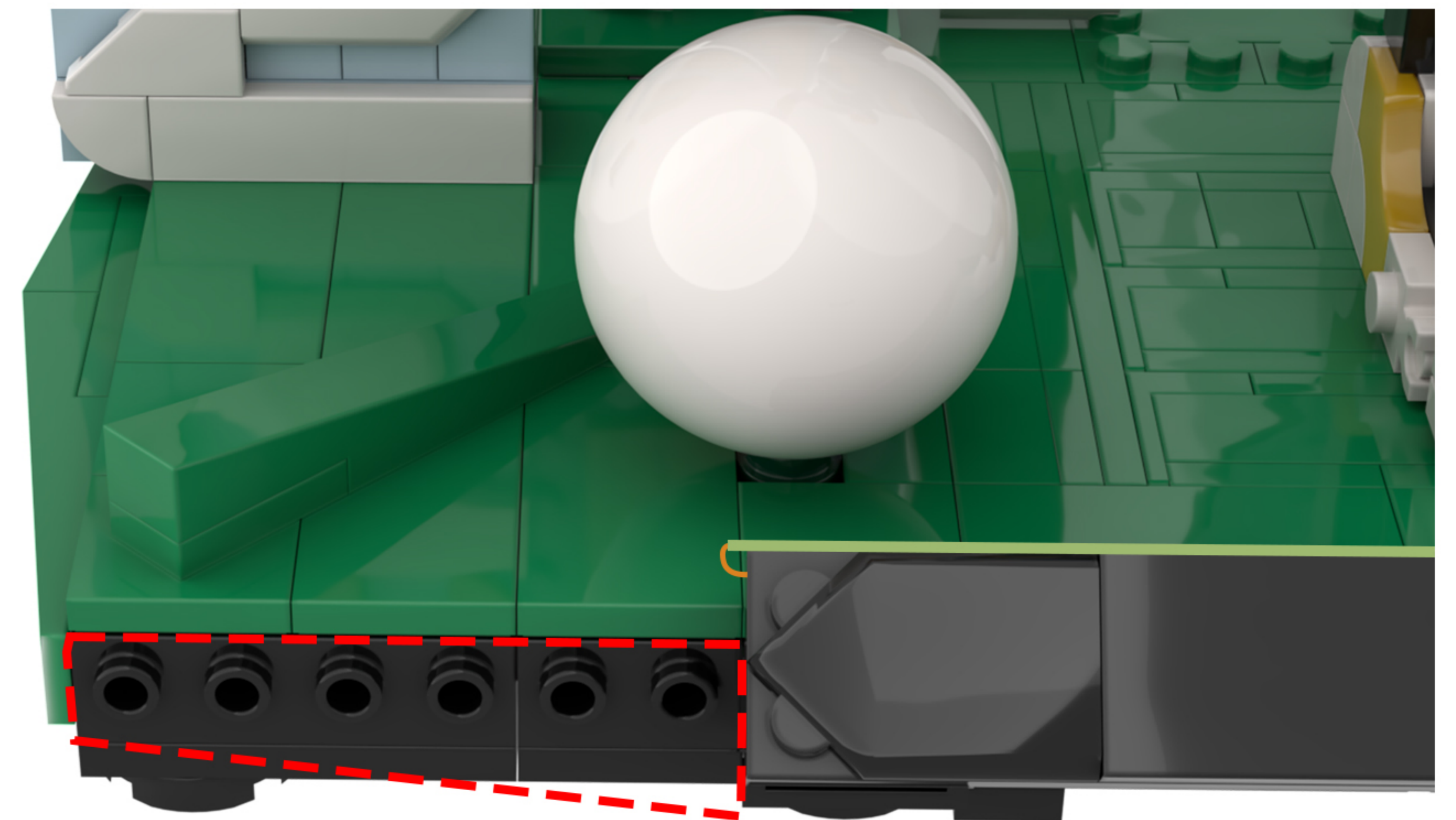

15

EN: Attach another light fixture to the building block.

DE: Befestige eine weitere Leuchte am Baustein.

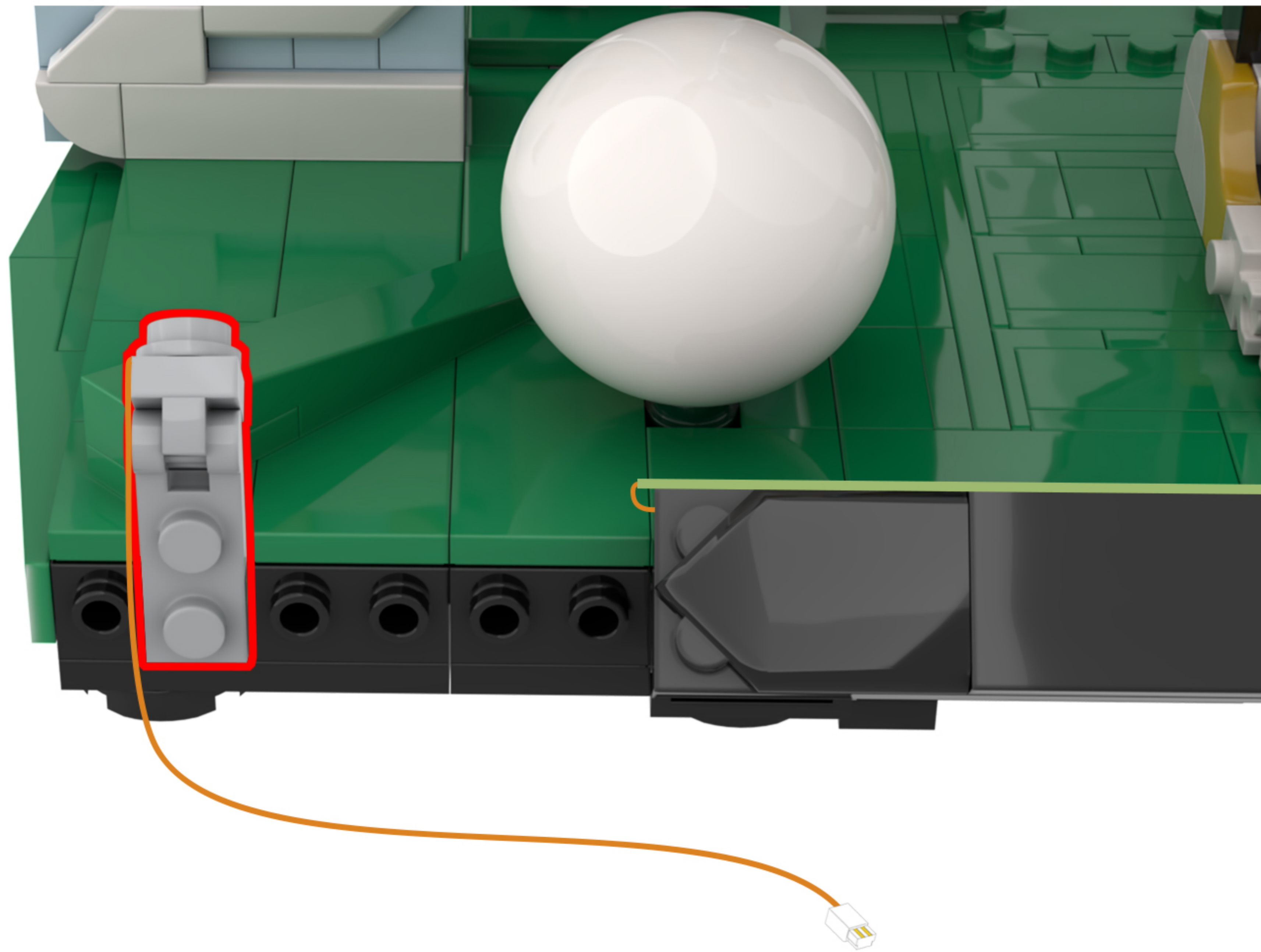

16

EN: Take the 2x2 and 2x4 base plates from Bag 2 and attach them to the building blocks, making sure to secure the light cord in place.

DE: Nimm die 2x2- und 2x4-Grundplatten aus Beutel 2 und befestige sie an den Bausteinen. Achte dabei darauf, das Lichtkabel sicher zu befestigen.

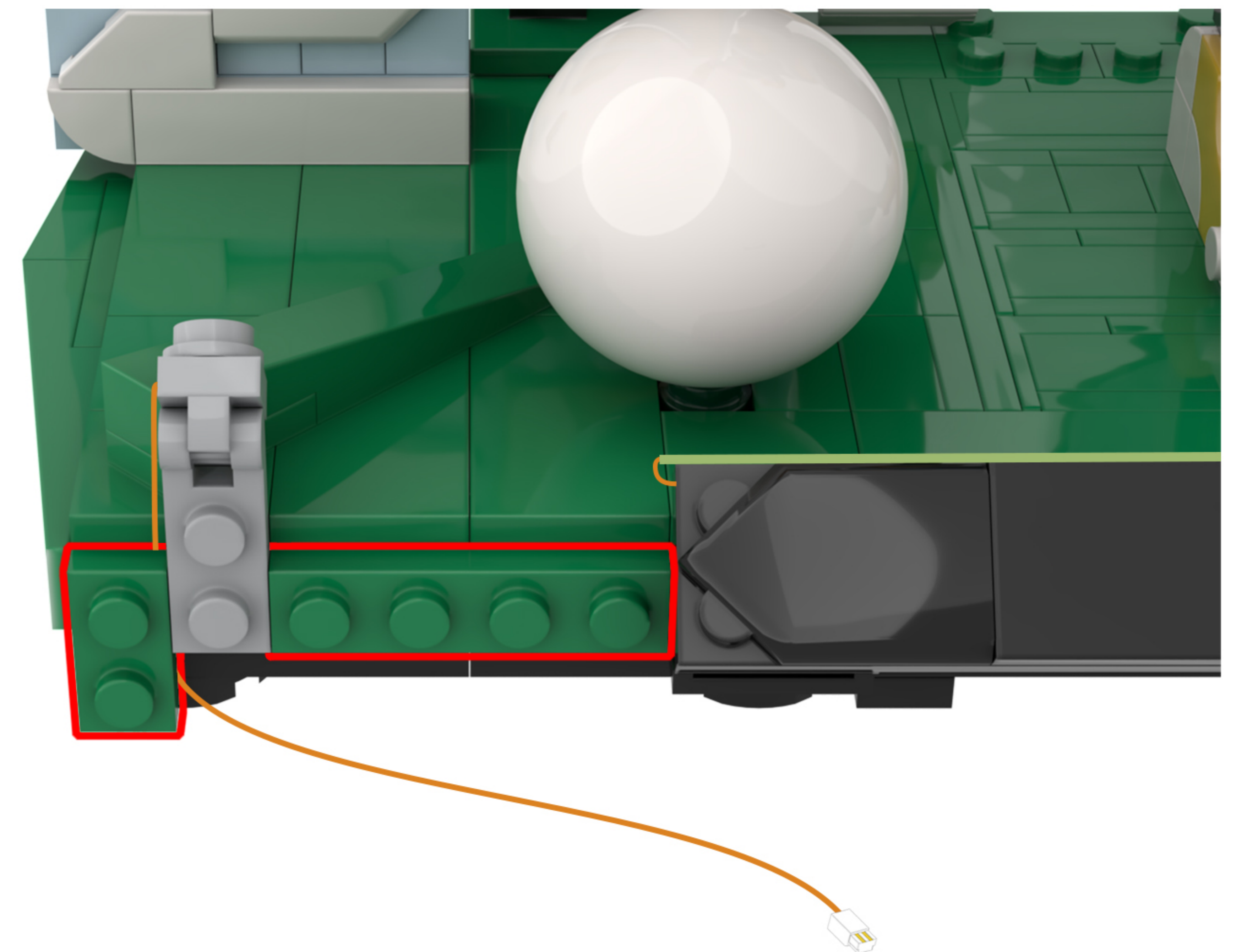
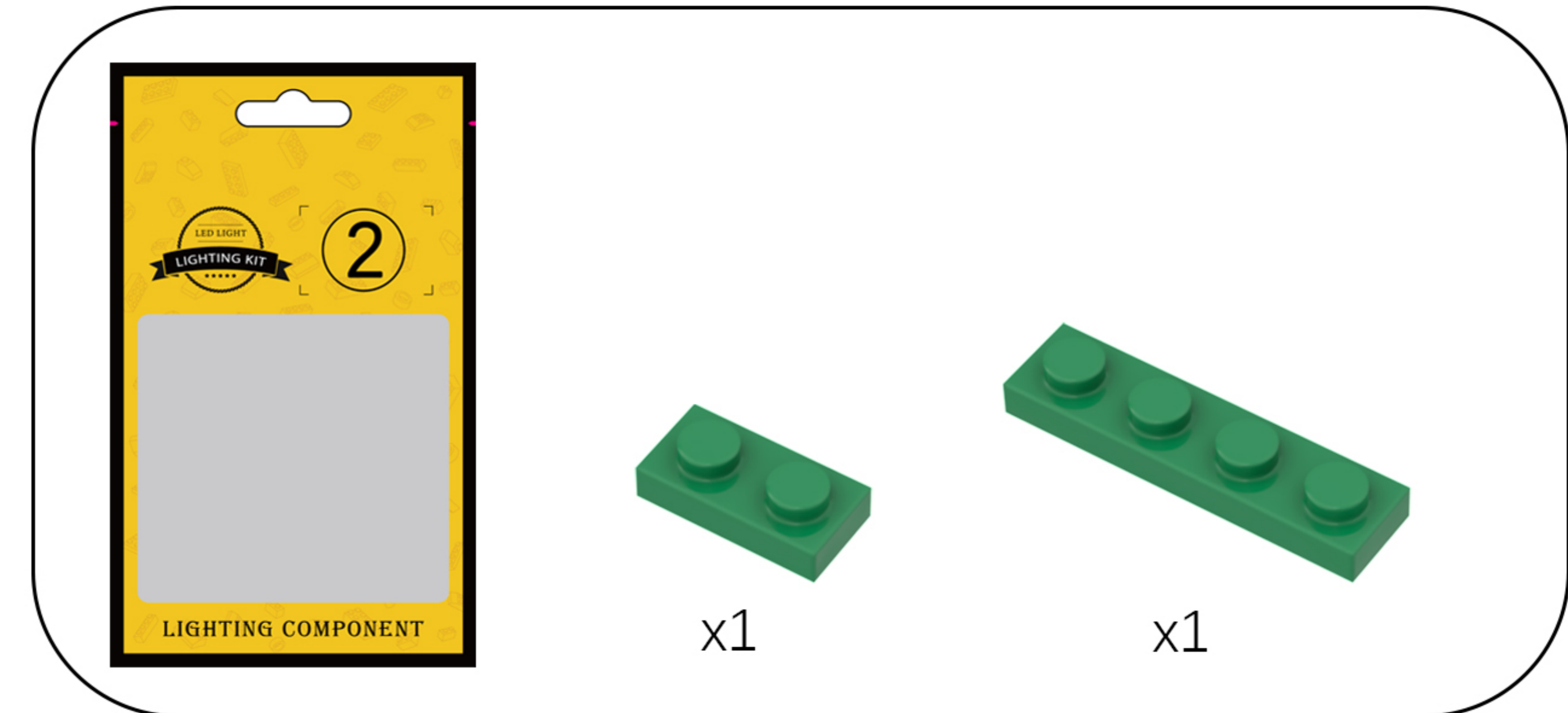

17

EN: Take out the disassembled building blocks and reassemble them.

DE: Nehmen Sie die zerlegten Bausteine heraus und setzen Sie sie wieder zusammen.

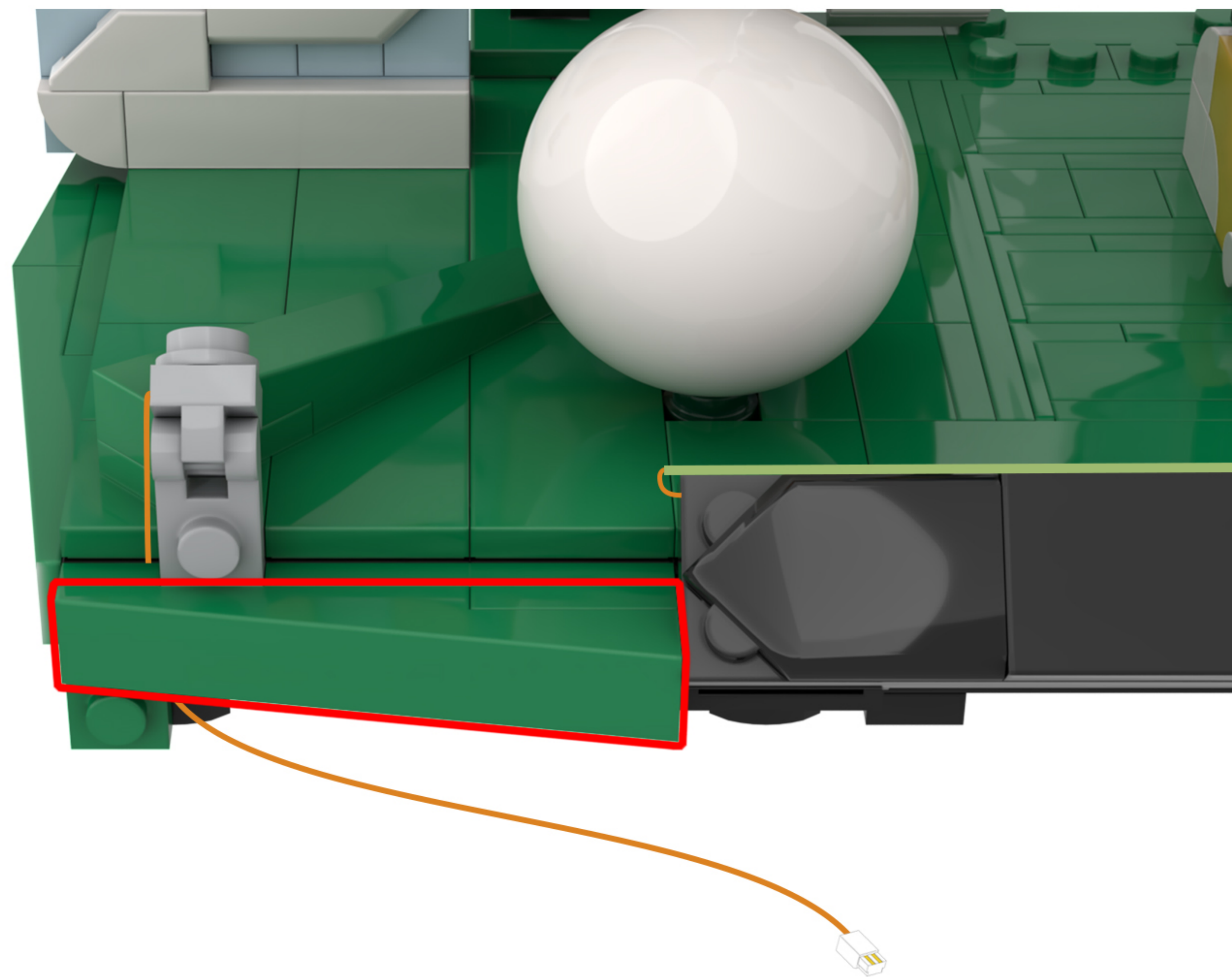
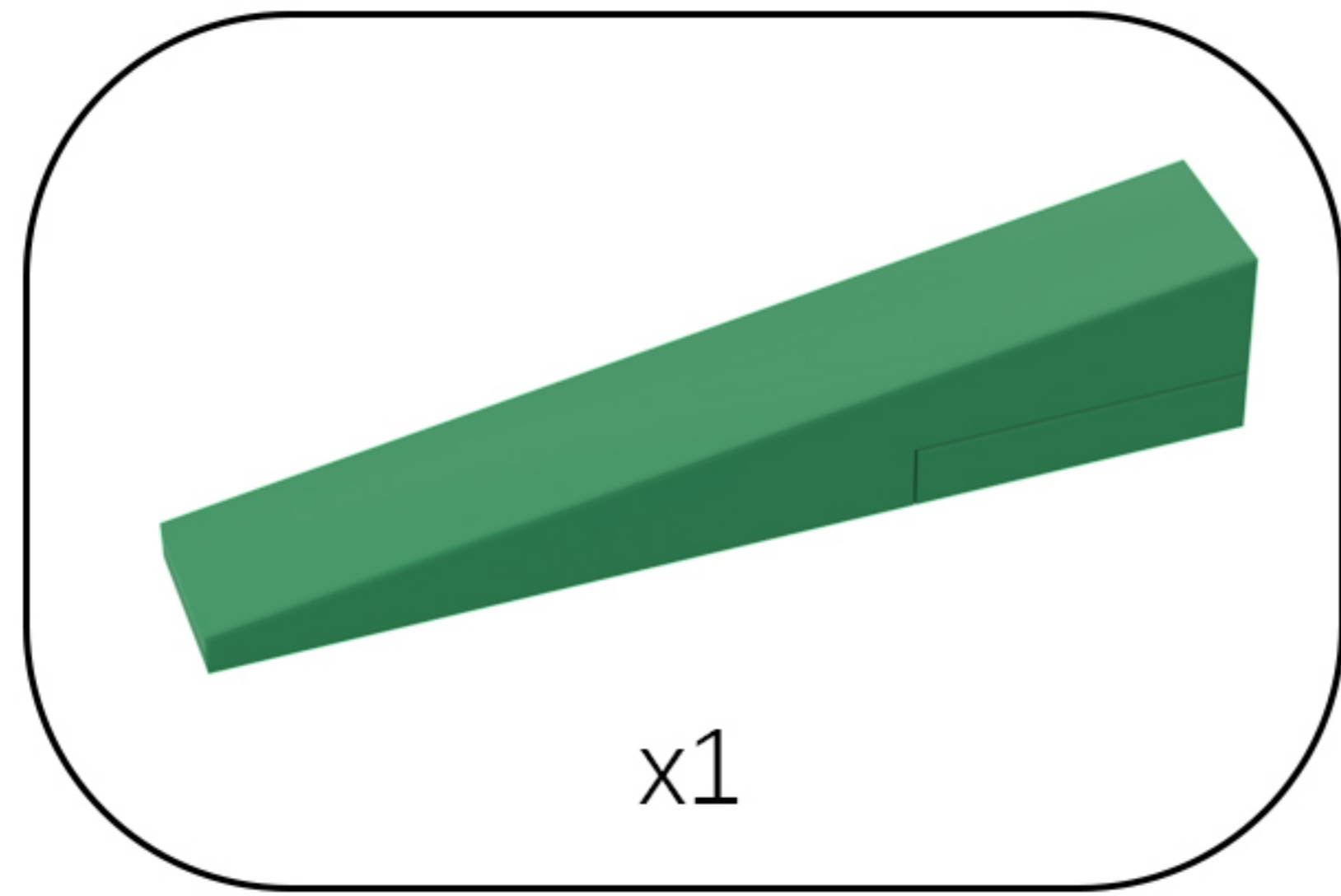

18

EN: Take a look at the building block component highlighted in the image.

DE: Schauen Sie sich die im Bild hervorgehobene Bausteinkomponente an.

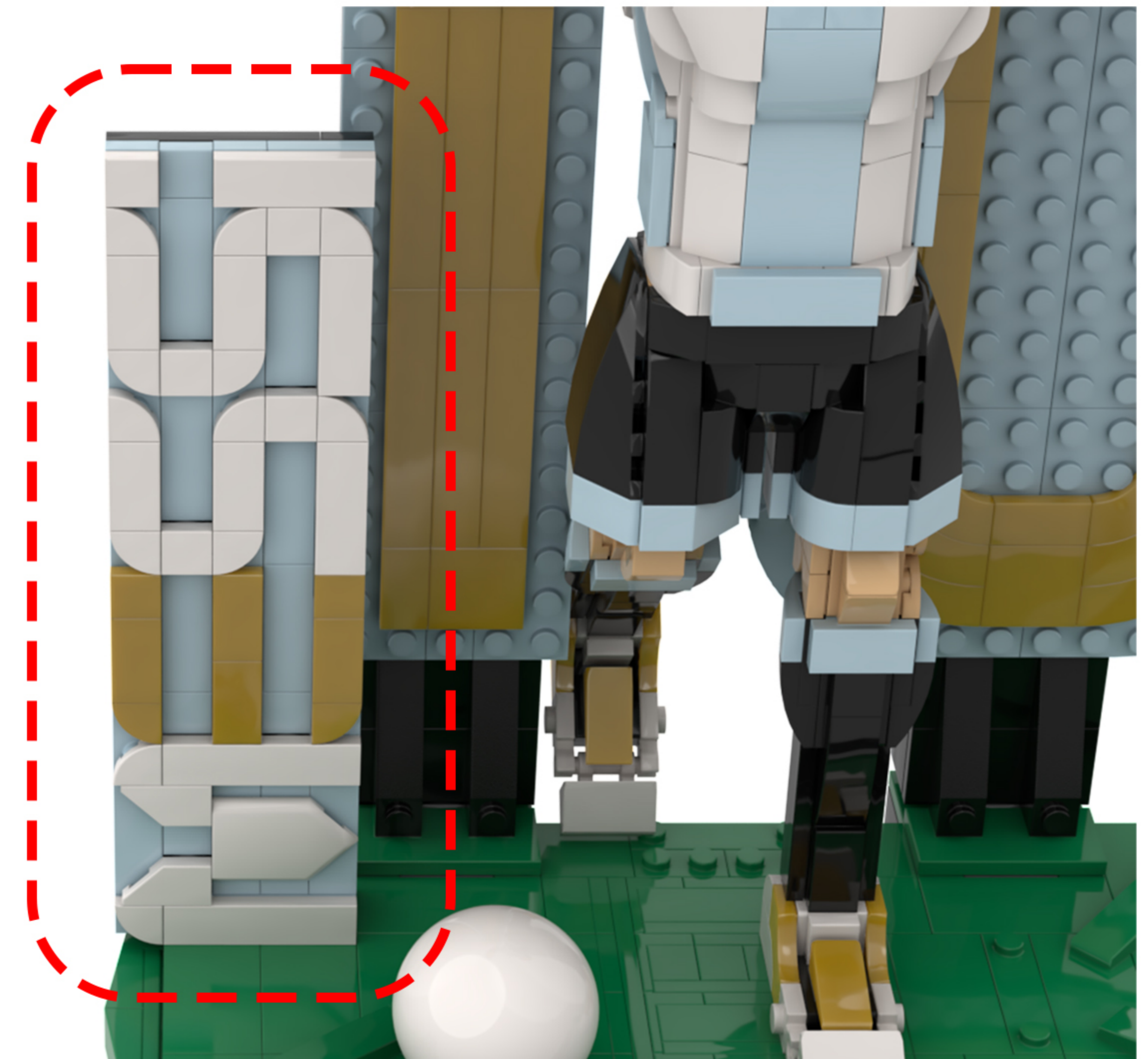

19

EN: Split as shown in the figure.

DE: Wie in der Abbildung gezeigt, teilen Sie es auf.

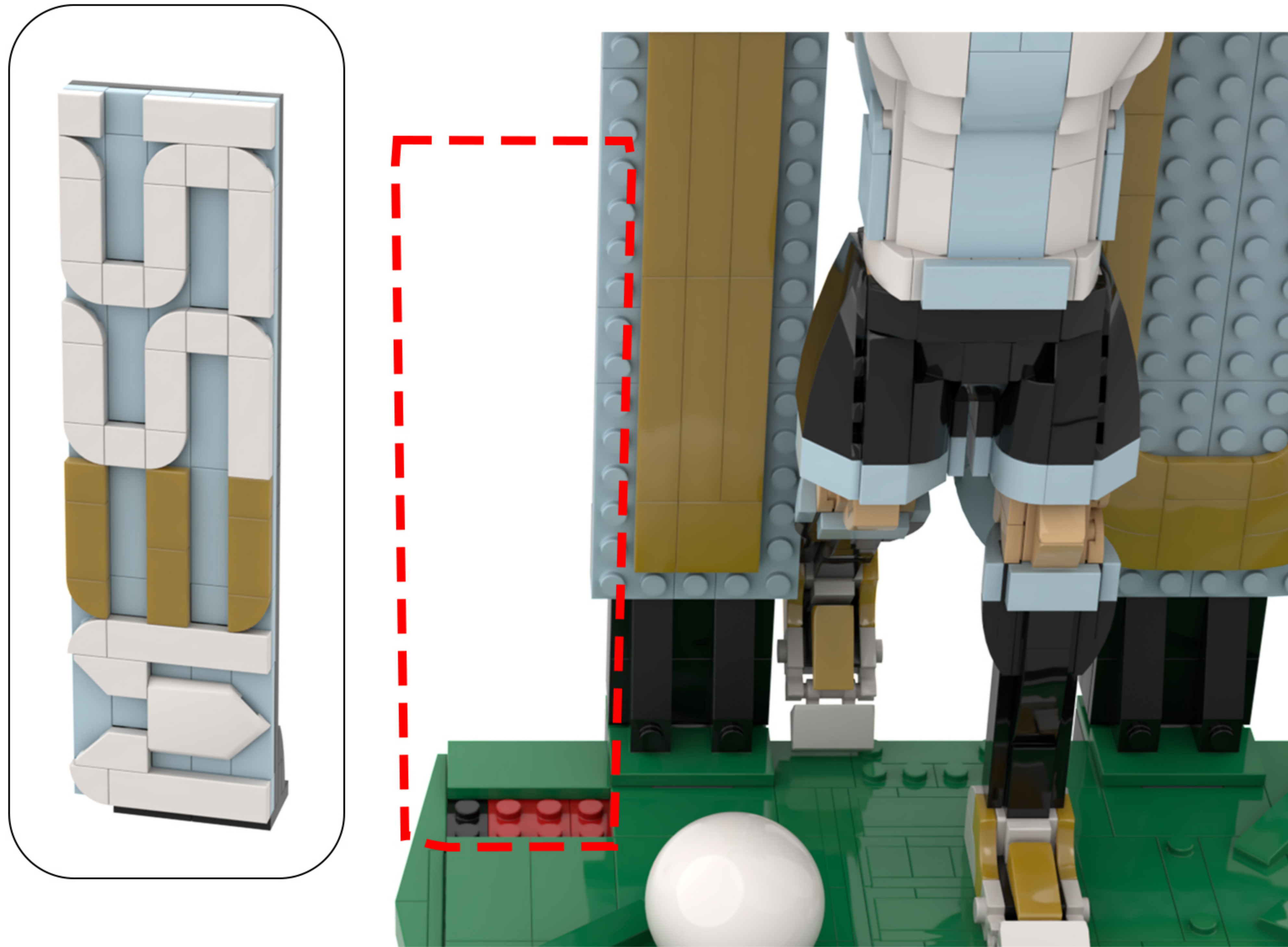

20

EN: Take out the string lights from Bag 3 and the disassembled building blocks.

DE: Nimm die Lichterkette aus Beutel 3 und die zerlegten Bausteine heraus.

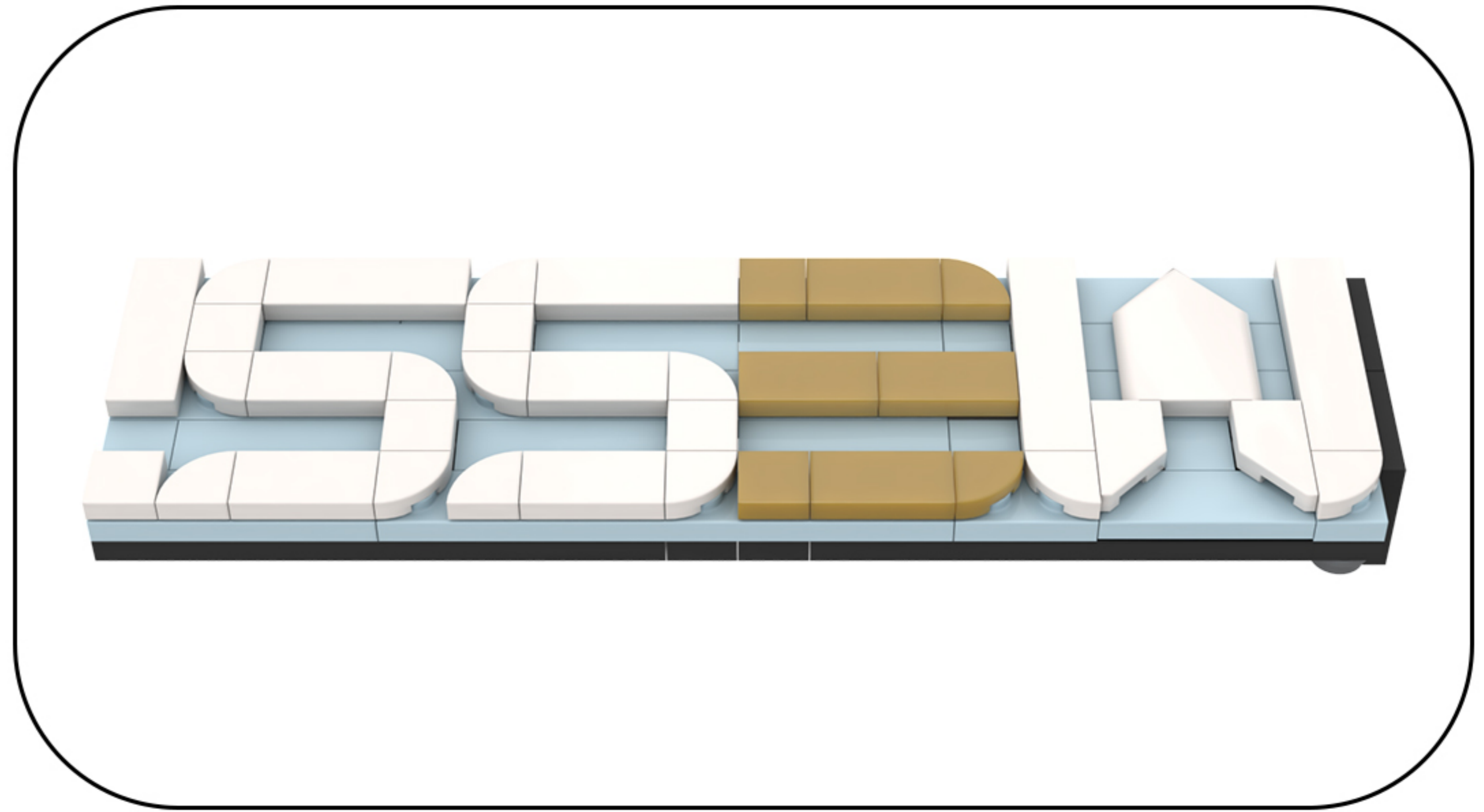
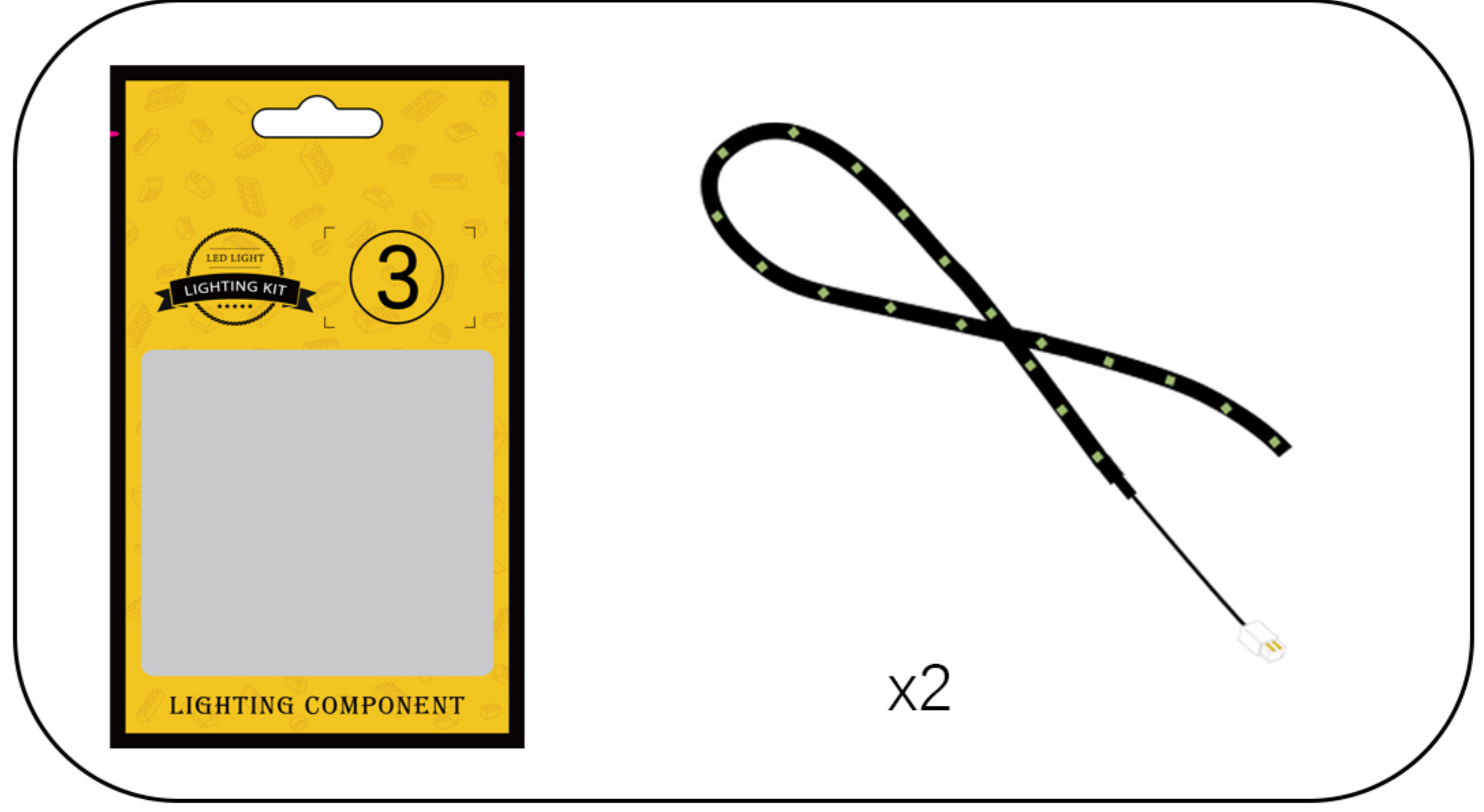

21

EN: Peel off the adhesive backing from one of the light strips and attach it to the location shown in the diagram.

DE: Ziehen Sie die Schutzfolie von einem der Leuchtstreifen ab und bringen Sie ihn an der in der Abbildung gezeigten Stelle an.

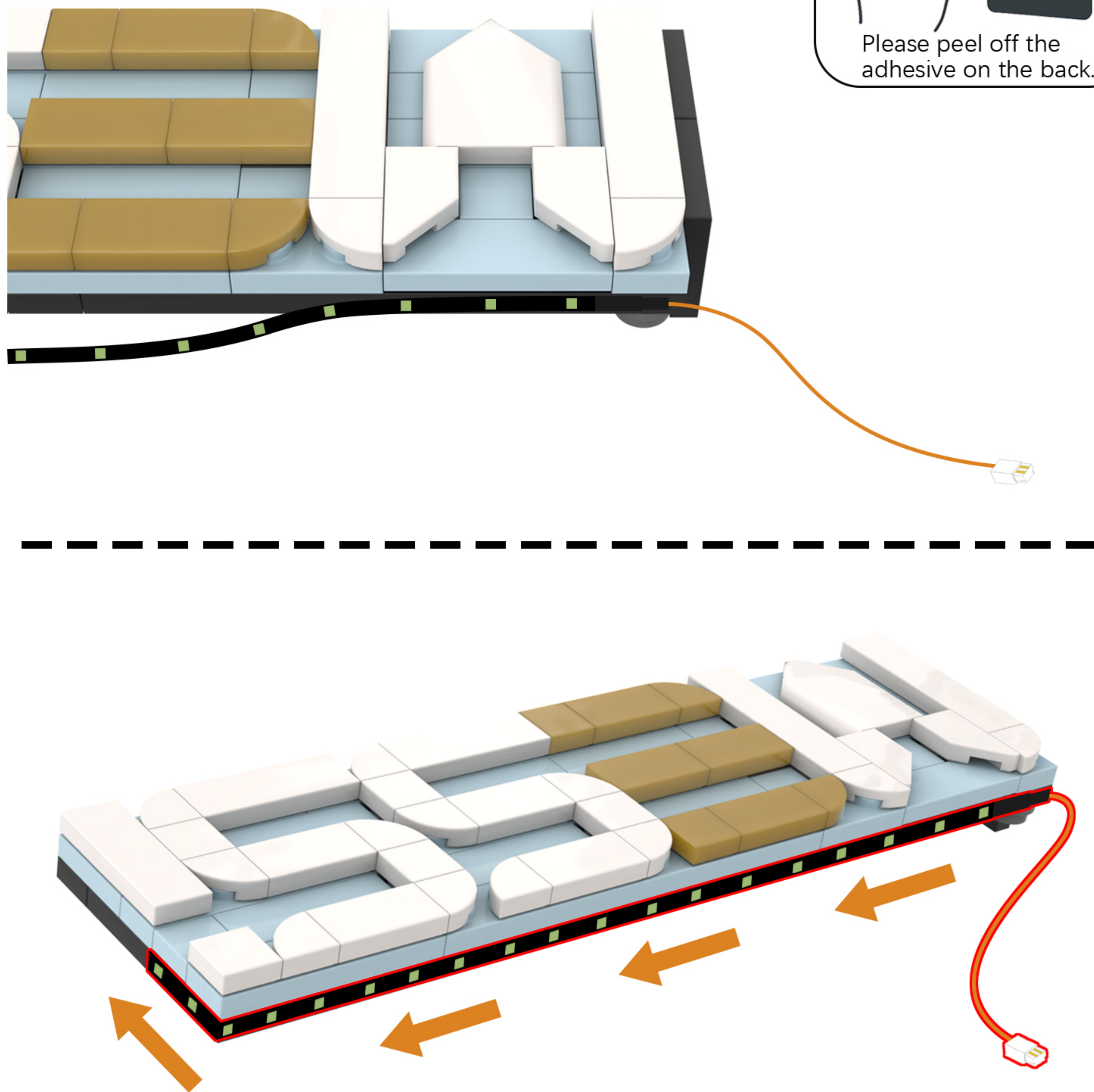

22

EN: Peel off the adhesive backing from the other strip of LED lights and attach it to the location shown in the diagram.

DE: Ziehen Sie die Schutzfolie von dem anderen LED-Streifen ab und befestigen Sie ihn an der in der Abbildung gezeigten Stelle.

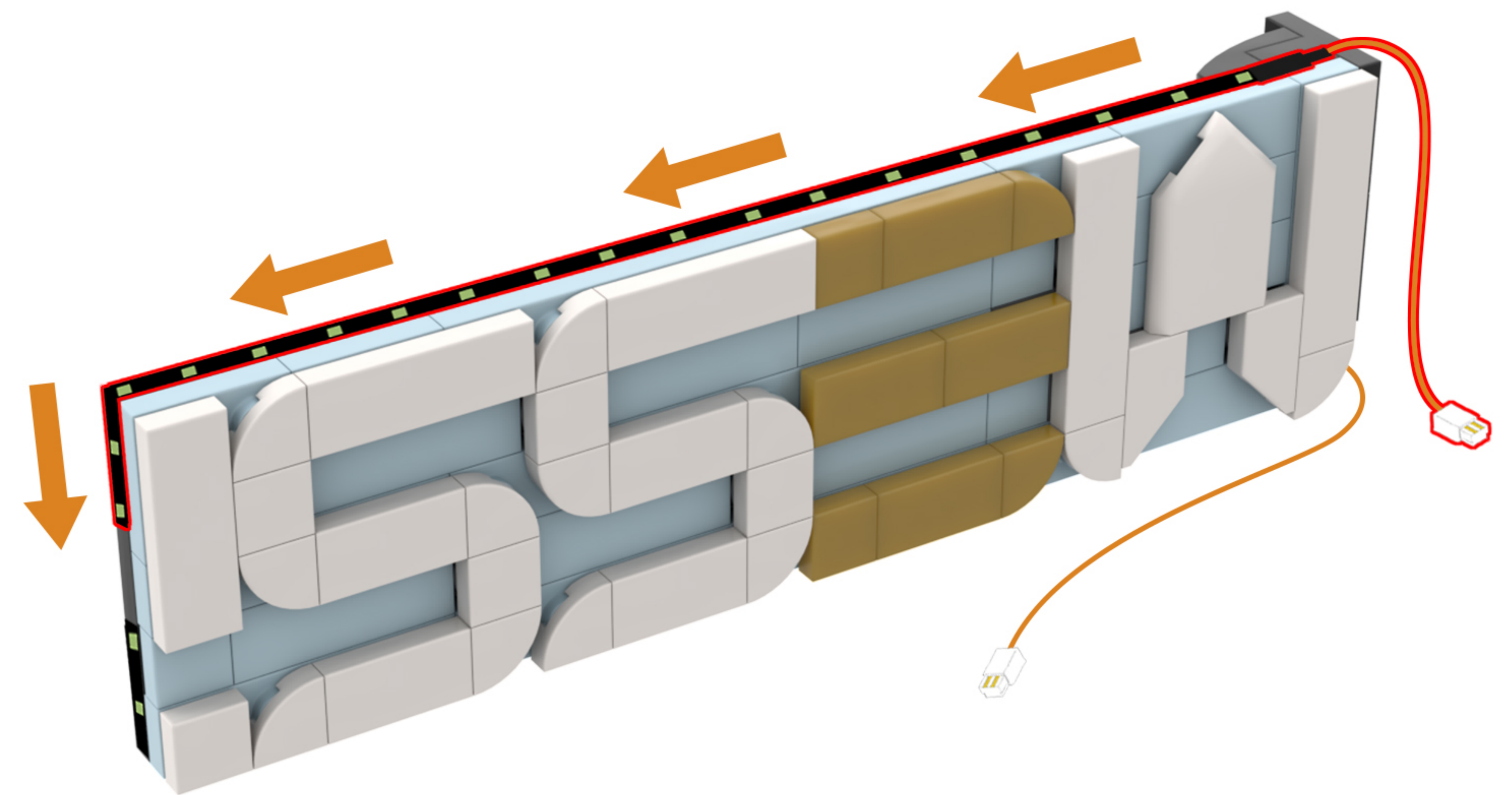

23

EN: Turn the model over and locate the two light cords shown in the diagram.

DE: Drehen Sie das Modell um und suchen Sie die beiden im Diagramm gezeigten Lichtkabel.

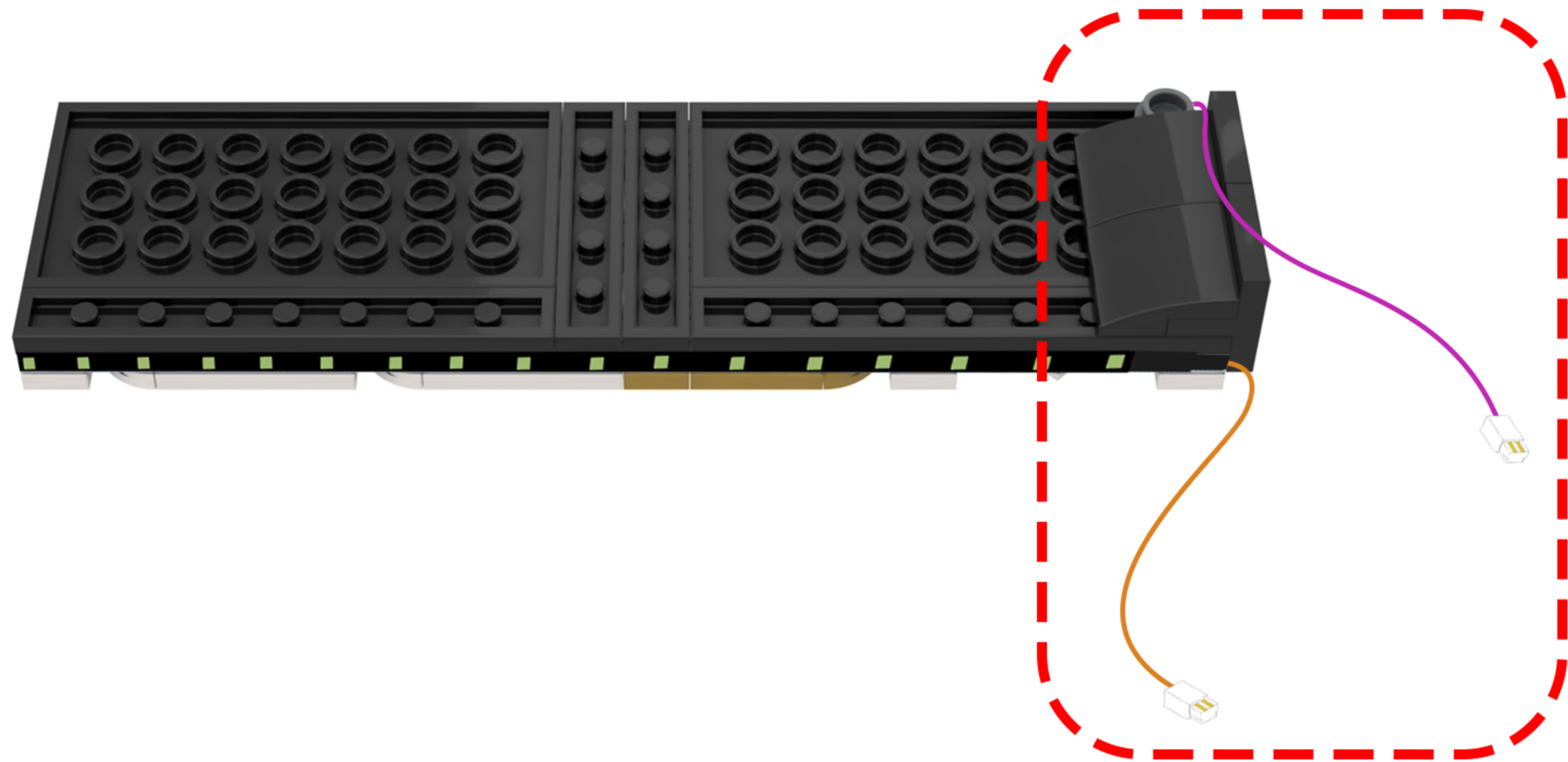
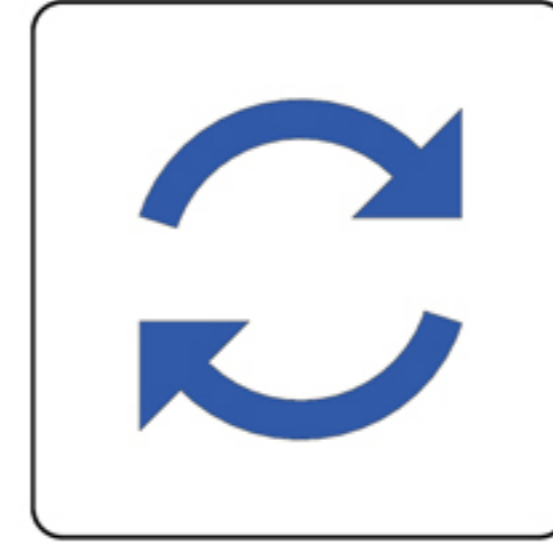

24

EN: Twist together a section of each of the two strands of lights.

DE: Verdrehen Sie jeweils ein Stück der beiden Lichterketten miteinander.

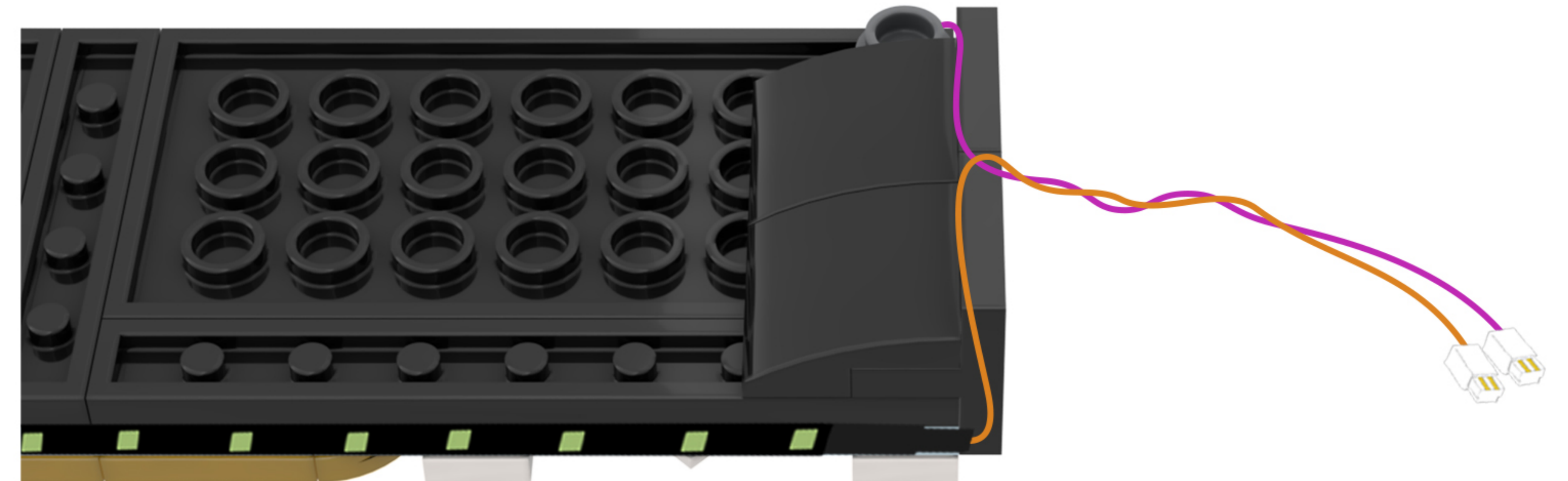

25

EN: Restore the building blocks.

DE: Stellen Sie die Bausteine wieder her.

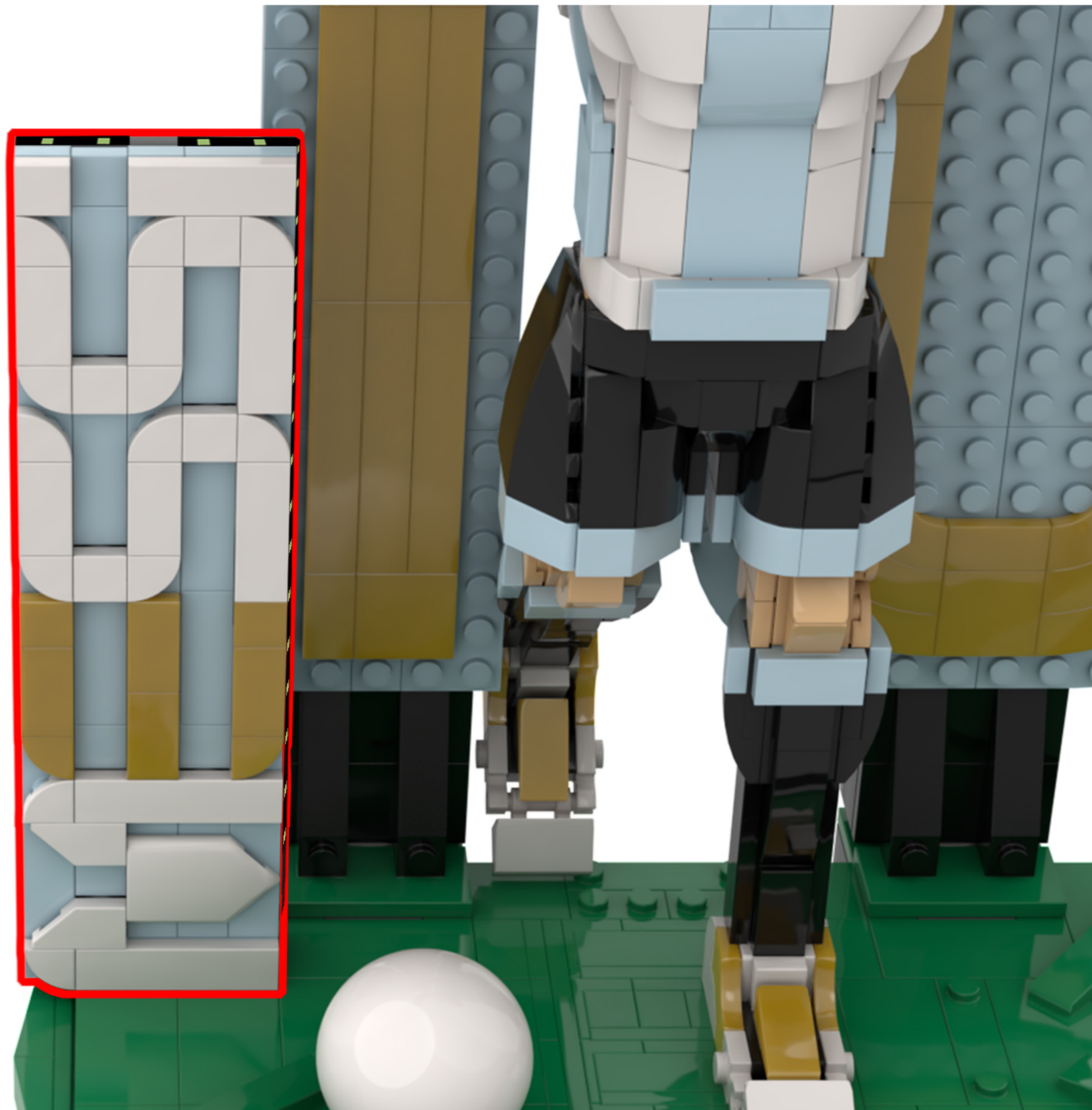

26

EN: Rotate the model to its back side.

DE: Drehen Sie das Modell auf die Rückseite.

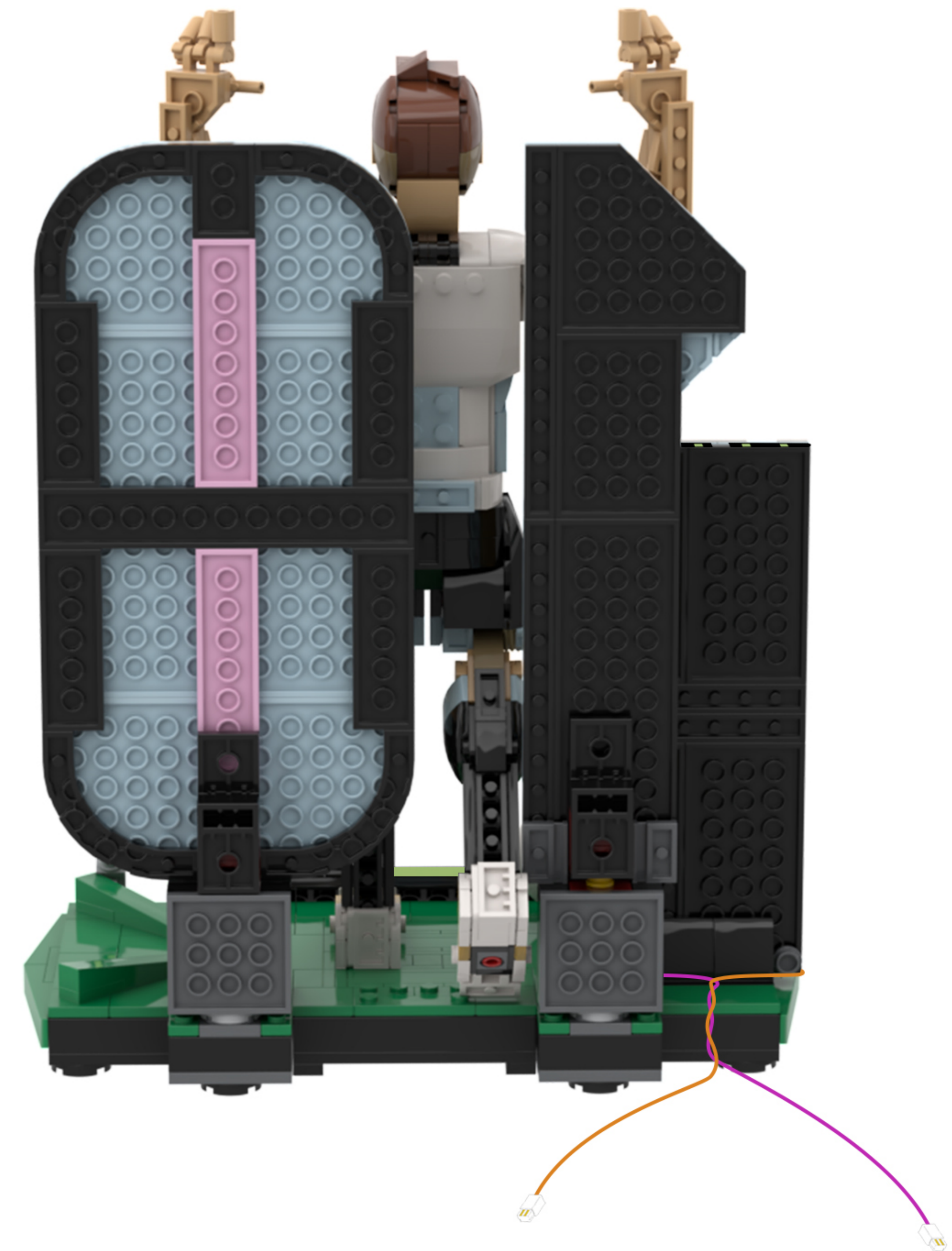
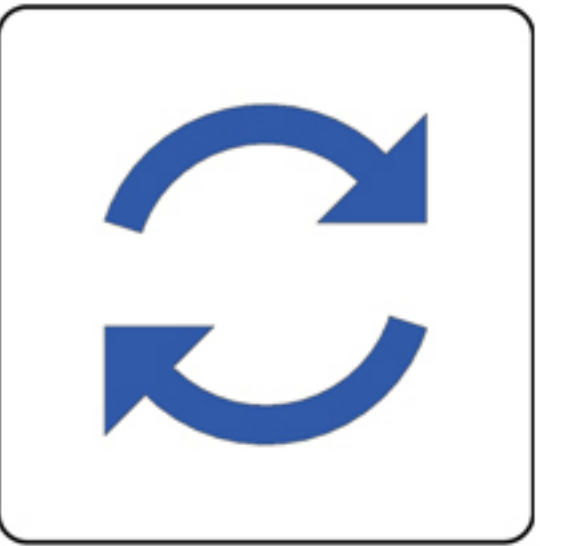

27

EN: Remove the building blocks one by one.

DE: Entfernen Sie die Bausteine nacheinander.

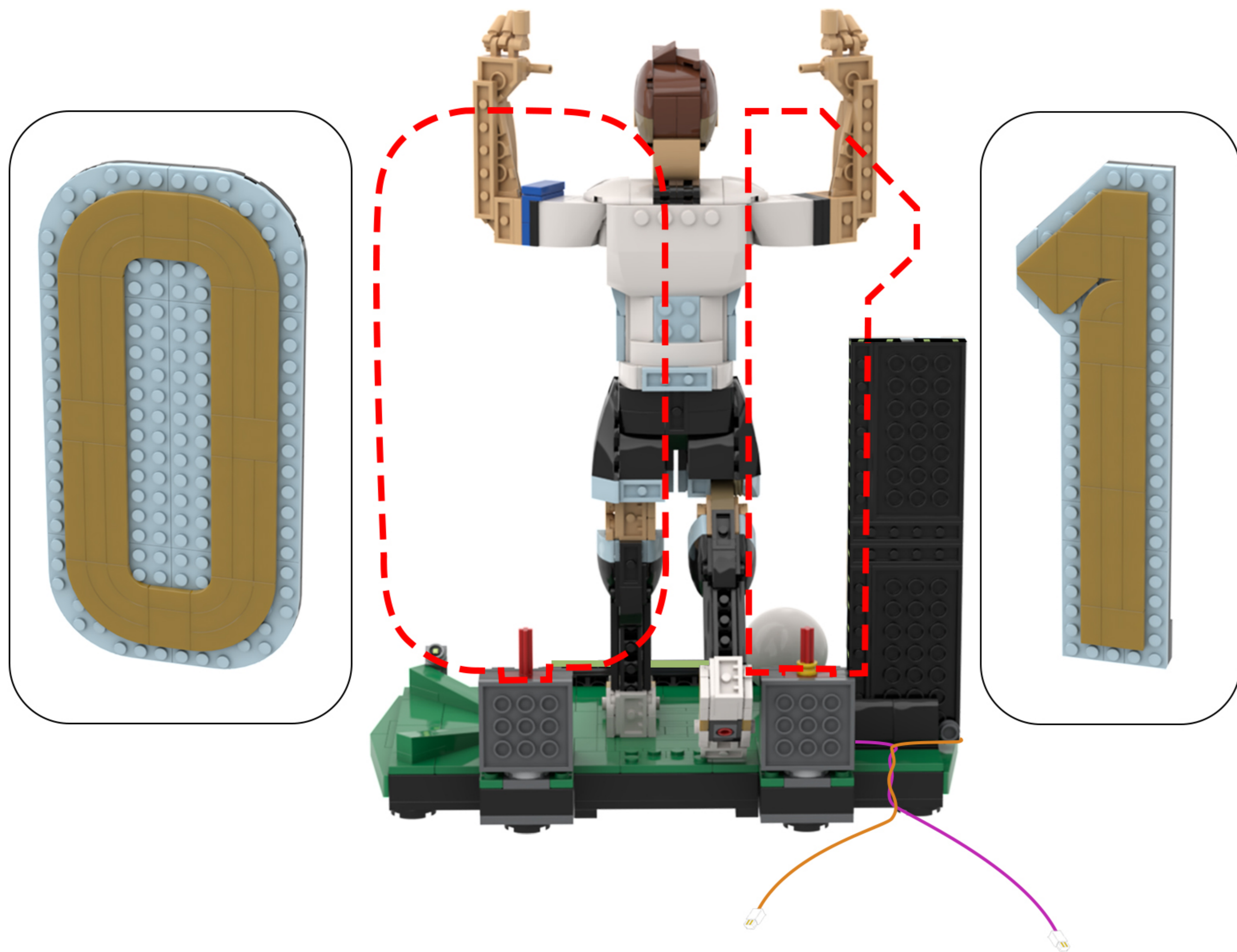

28

EN: Take the COB light strip from Bag 4 and the disassembled building blocks, then flip the building blocks over to their reverse side.

DE: Nimm den COB-Lichtstreifen aus Beutel 4 und die zerlegten Bausteine und drehe die Bausteine auf die Rückseite.

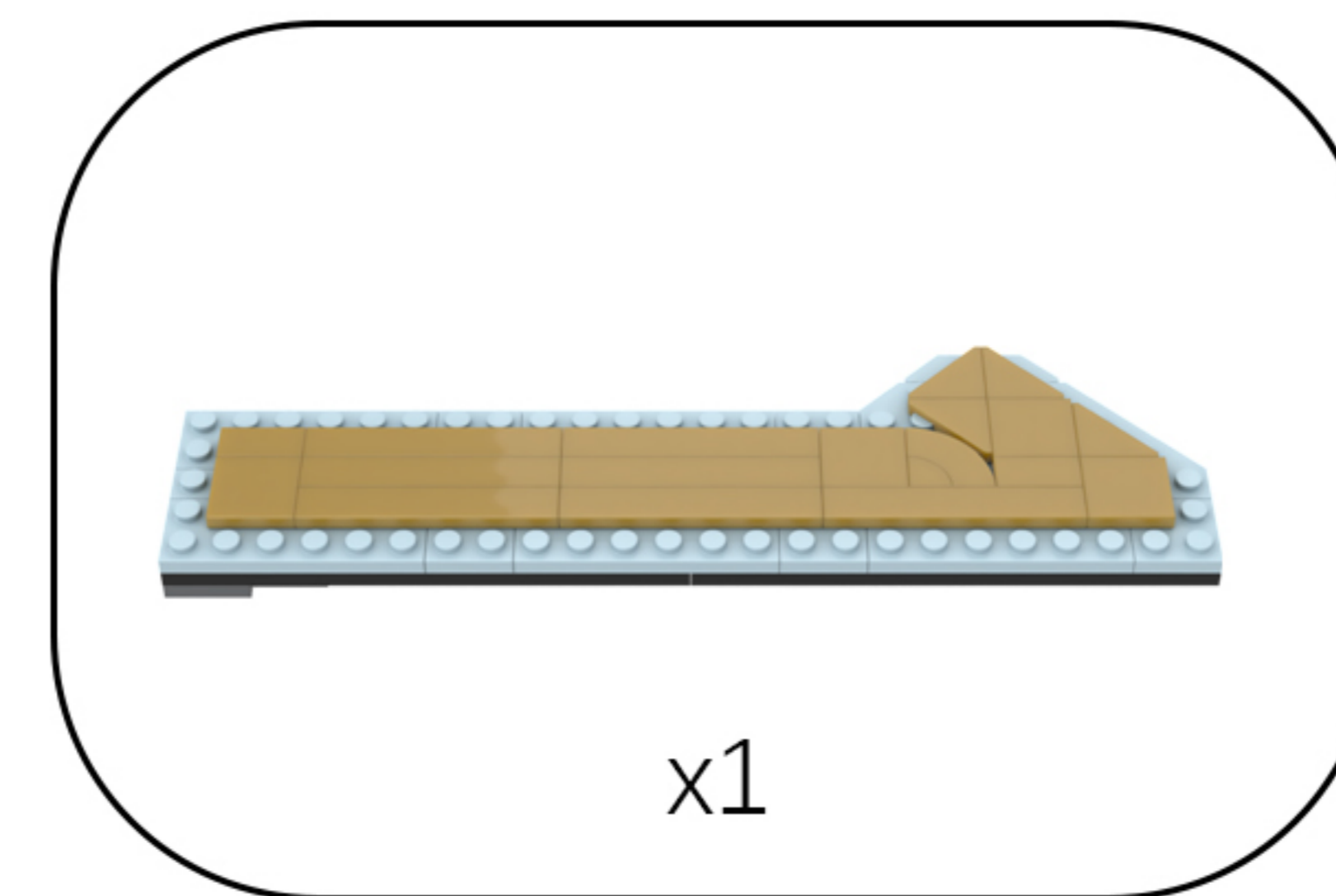
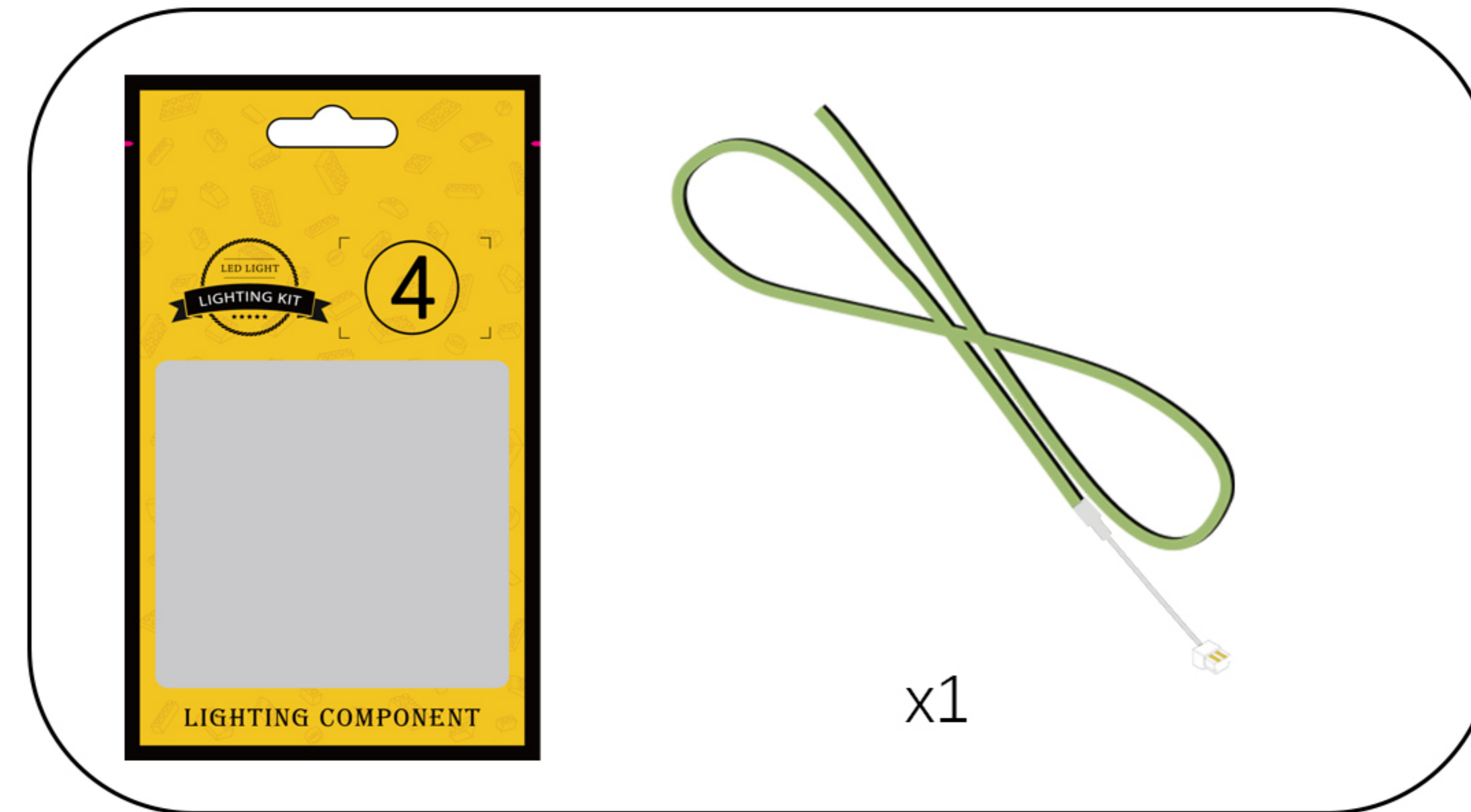

29

EN: Peel off the adhesive backing from the COB light strip and attach it to the location shown in the illustration.

DE: Ziehen Sie die Schutzfolie vom COB-Lichtband ab und bringen Sie es an der in der Abbildung gezeigten Stelle an.

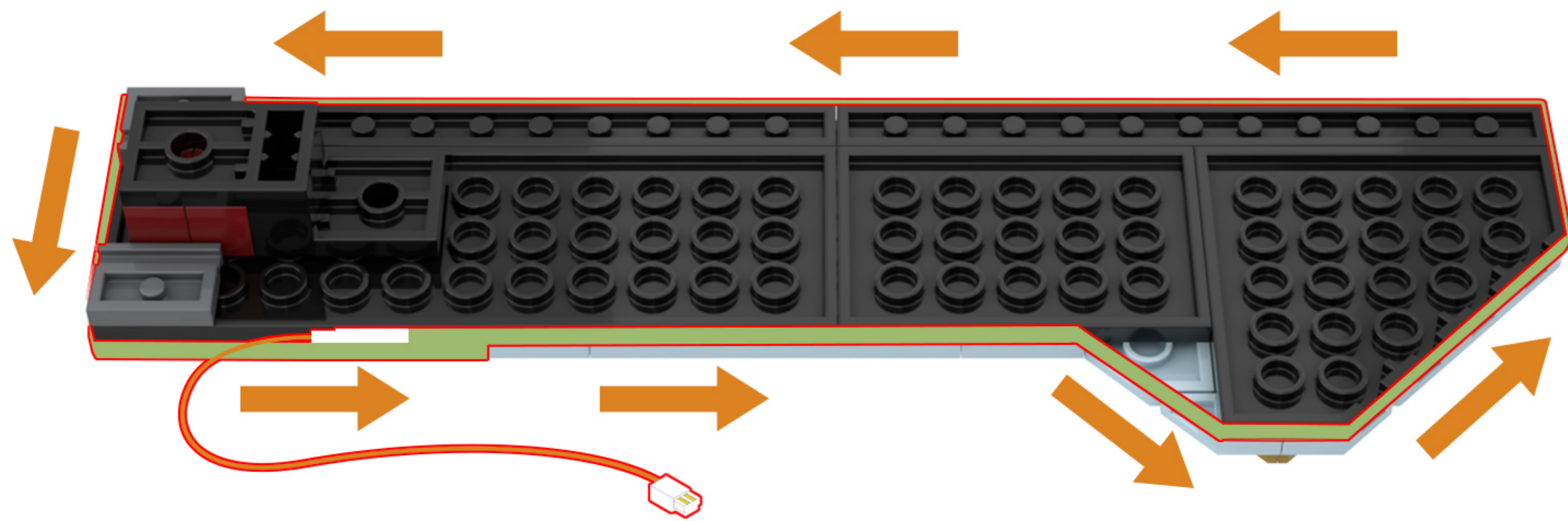
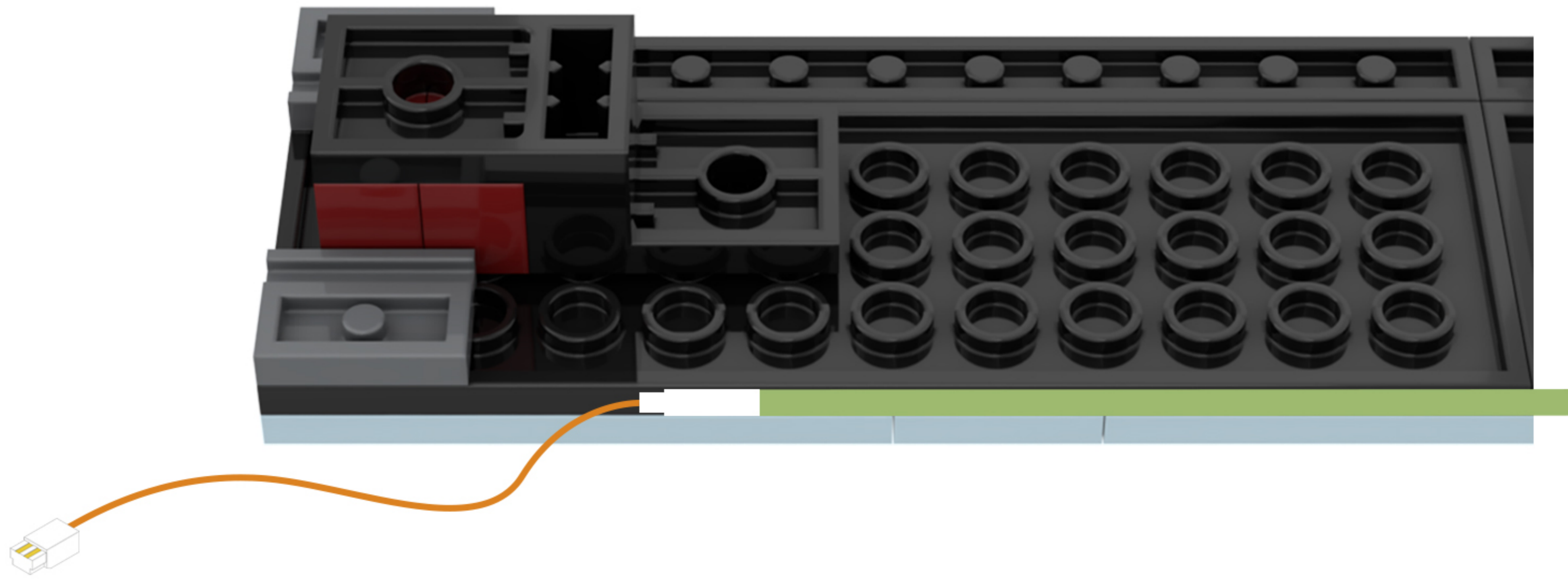

30

EN: Take the COB light strip from Bag 5 and the disassembled building blocks, then flip the building blocks over to their reverse side.

DE: Nimm den COB-Lichtstreifen aus Beutel 5 und die zerlegten Bausteine und drehe die Bausteine auf die Rückseite.



x1

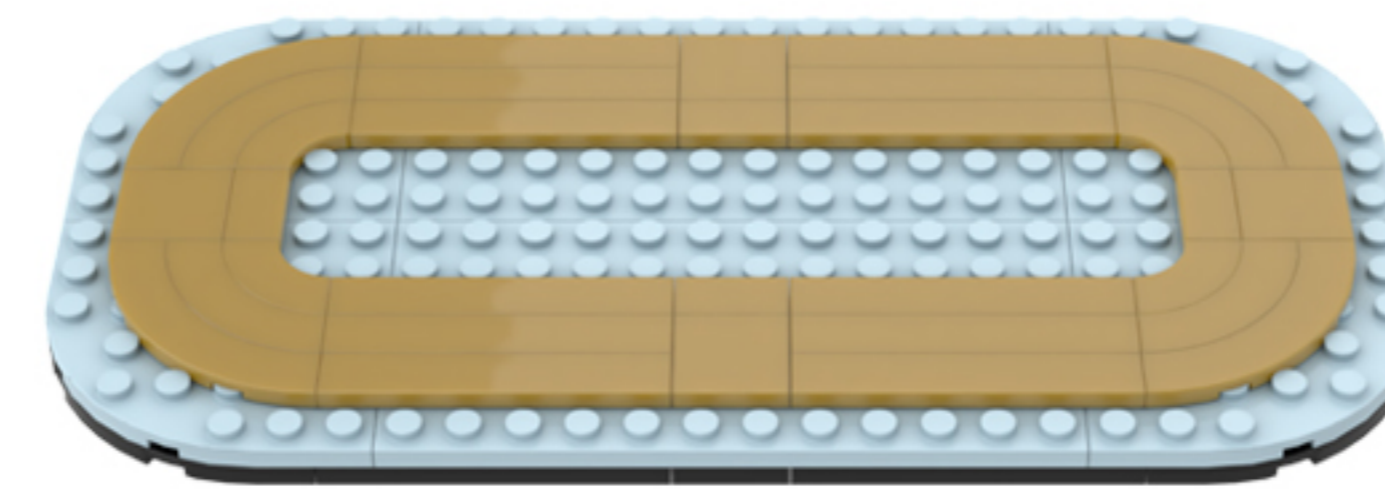

x1

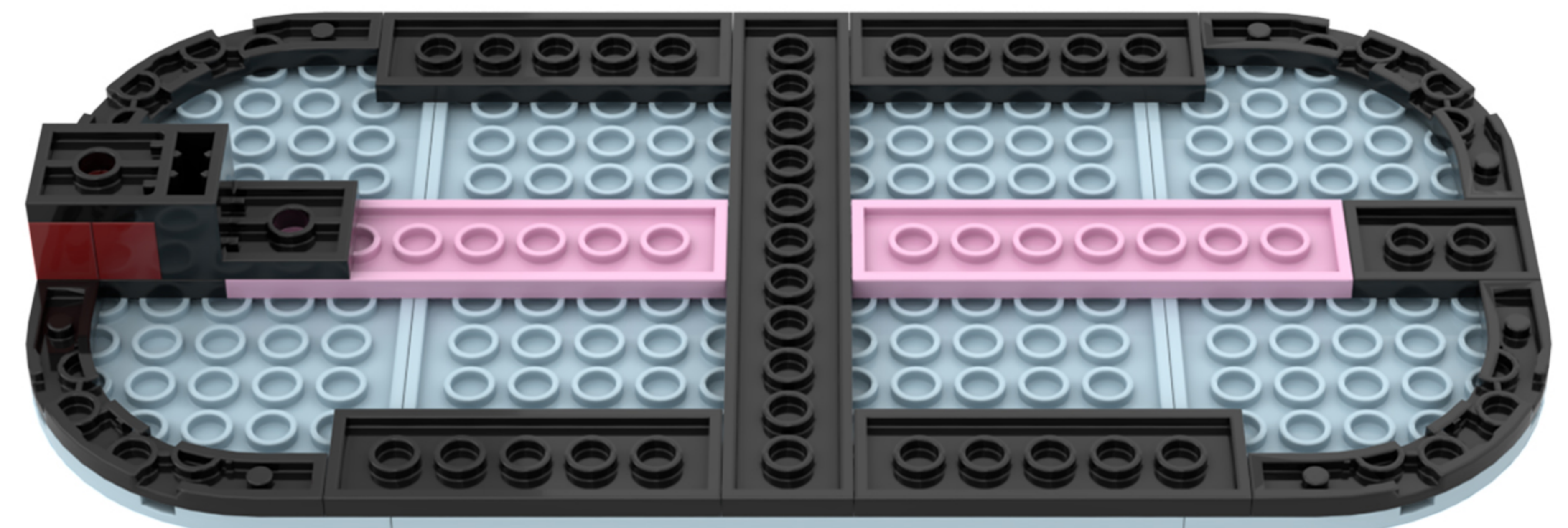

31

EN: Peel off the adhesive backing from the COB light strip and attach it to the location shown in the illustration.

DE: Ziehen Sie die Schutzfolie vom COB-Lichtband ab und bringen Sie es an der in der Abbildung gezeigten Stelle an.

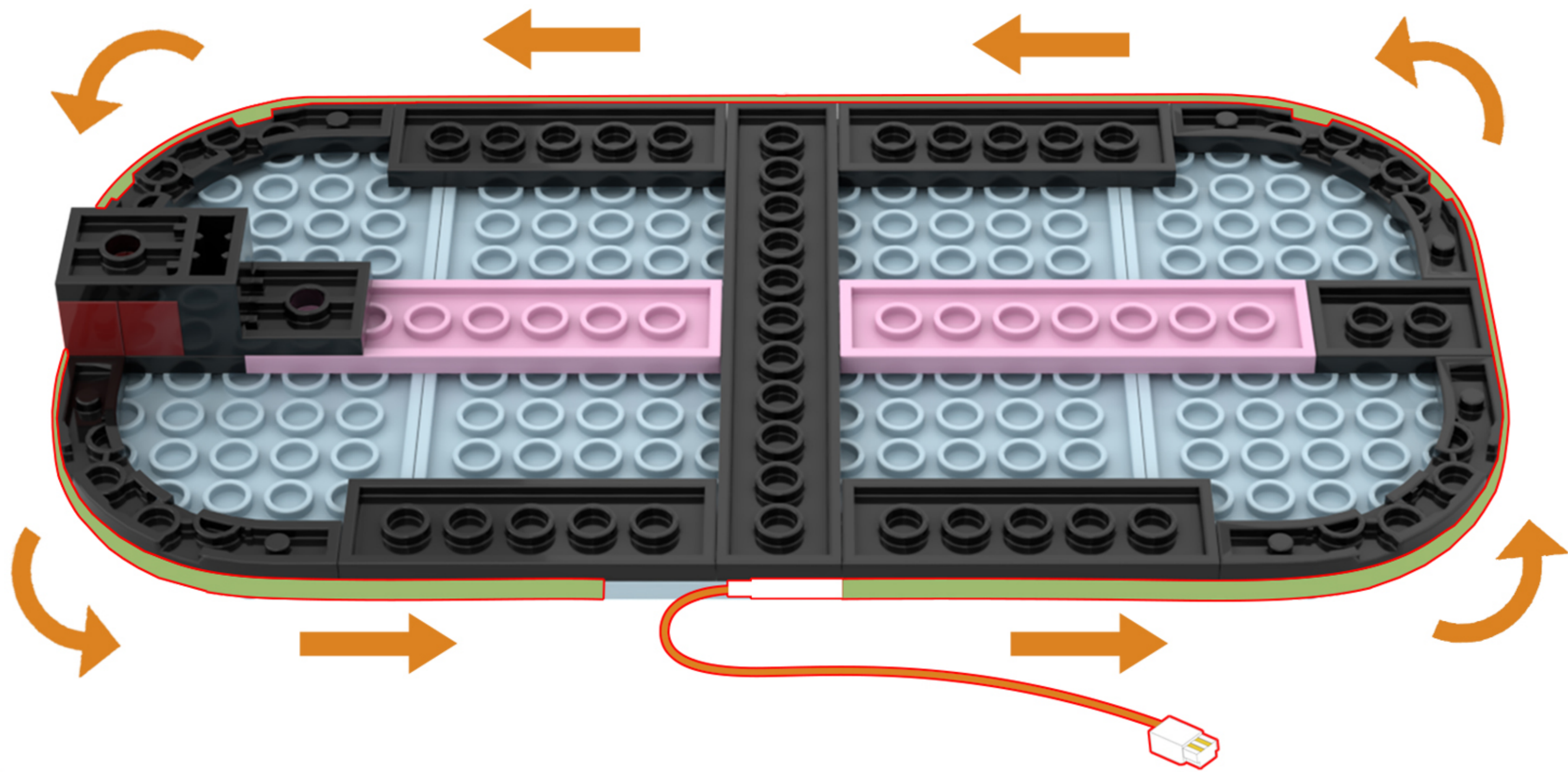
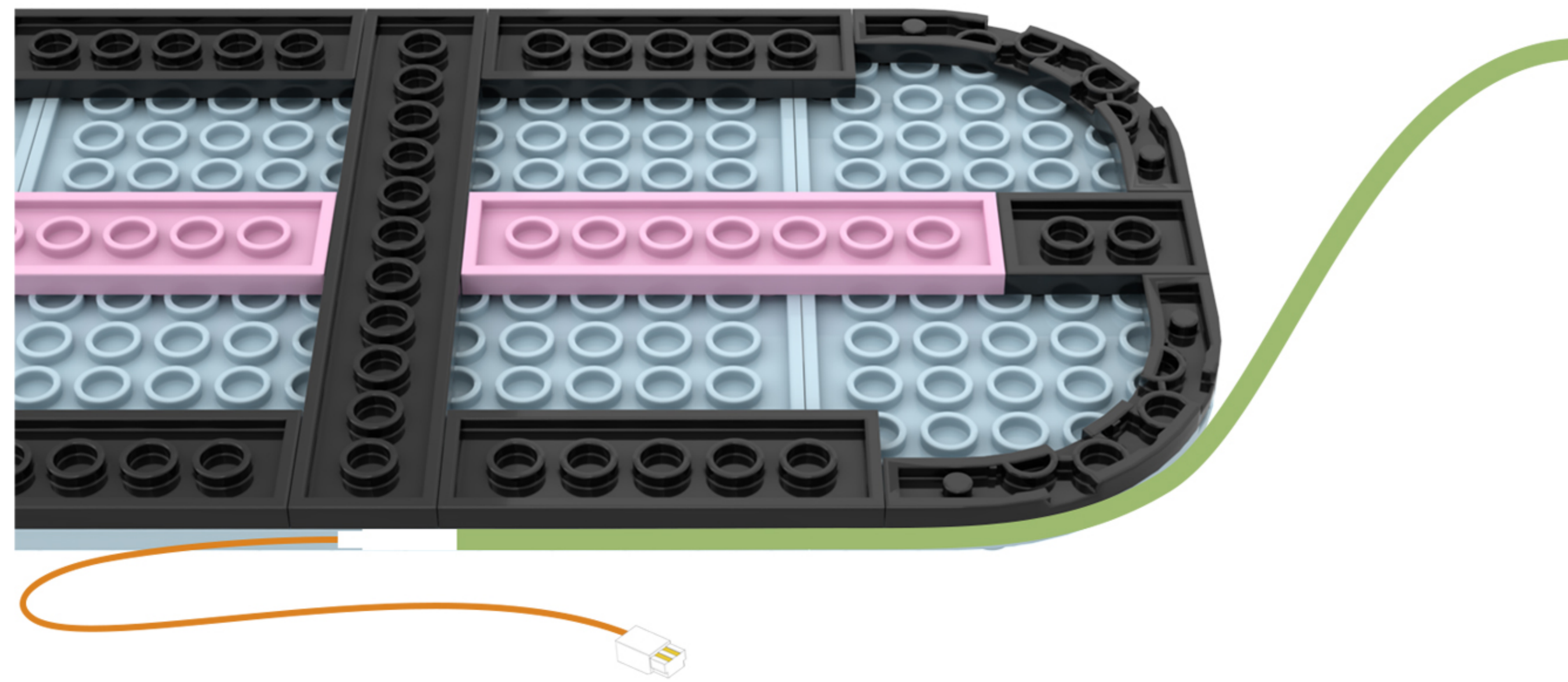

32

EN: Take the expansion board and the connecting cable out of Bag 6 and connect them together.

DE: Nehmen Sie die Erweiterungskarte und das Verbindungskabel aus Beutel 6 und verbinden Sie beide miteinander.

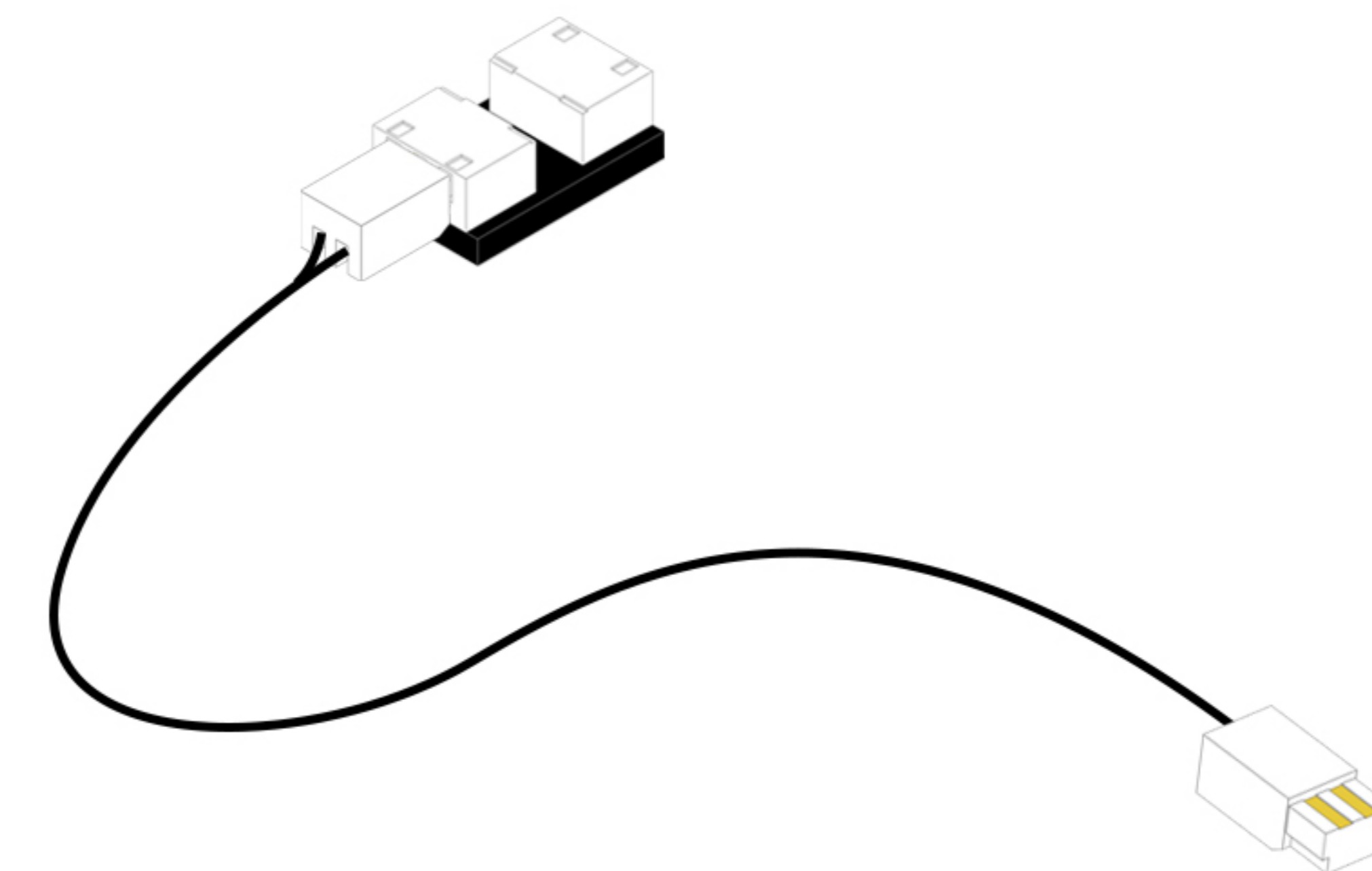
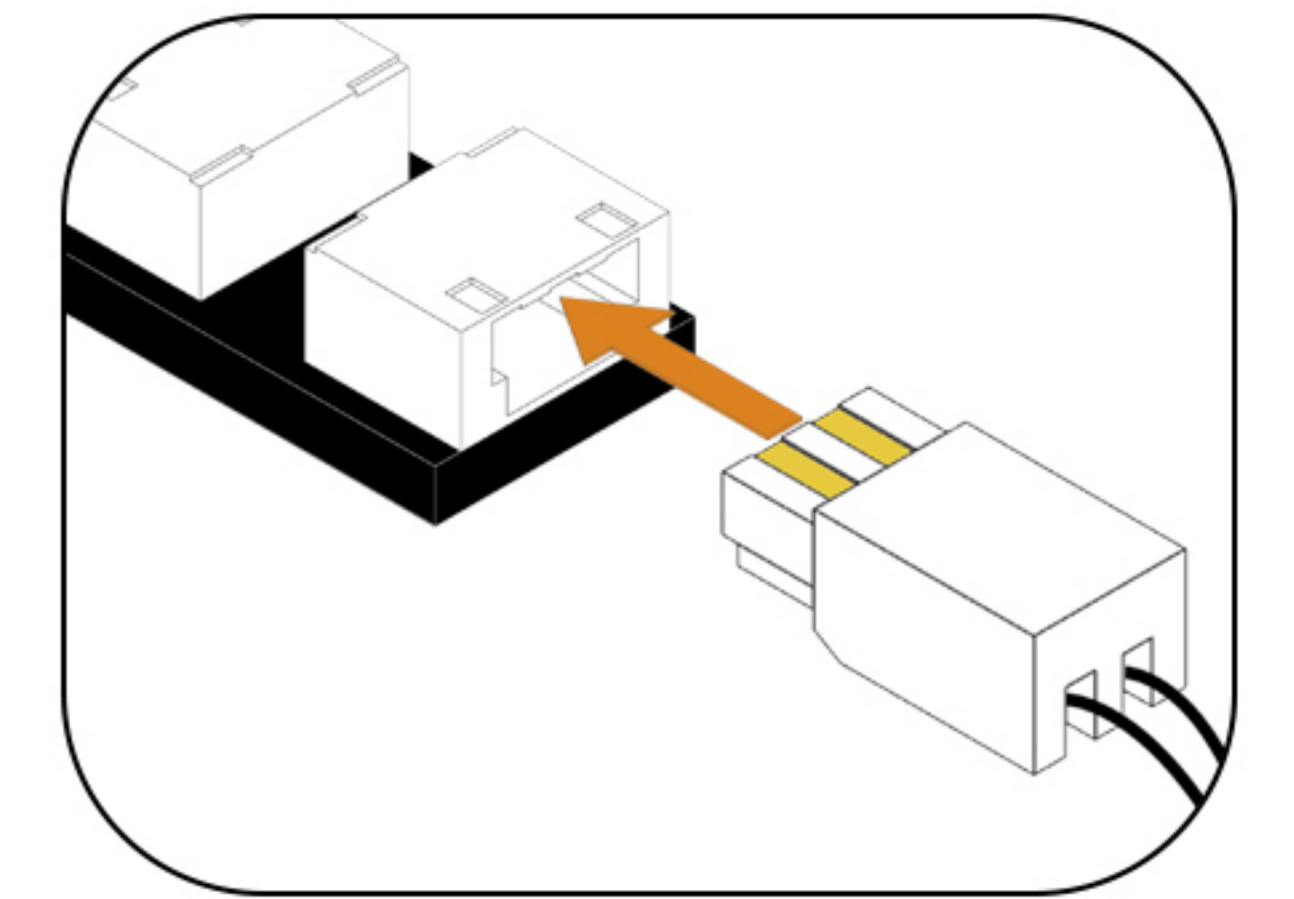
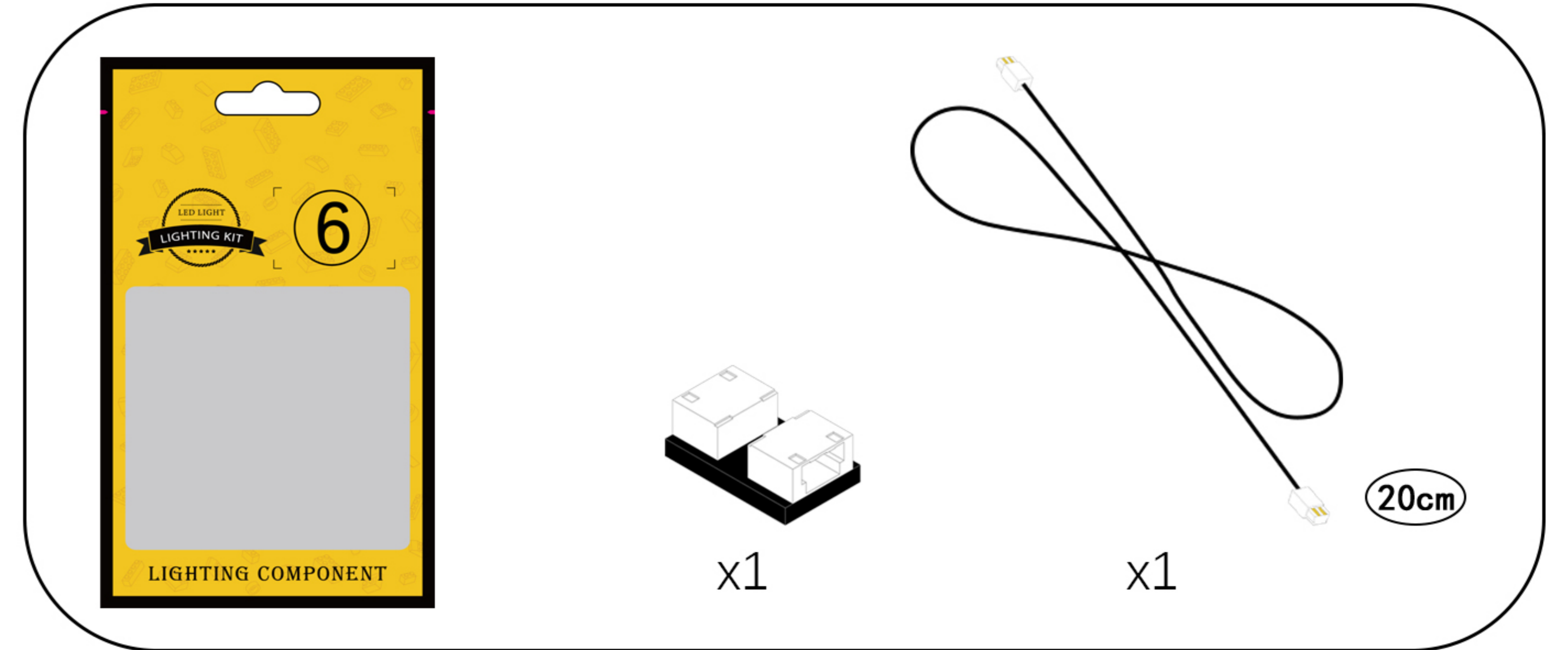

33

EN: Connect the lamp wires to the expansion board.

DE: Verbinden Sie die Lampenkabel mit der Erweiterungskarte.

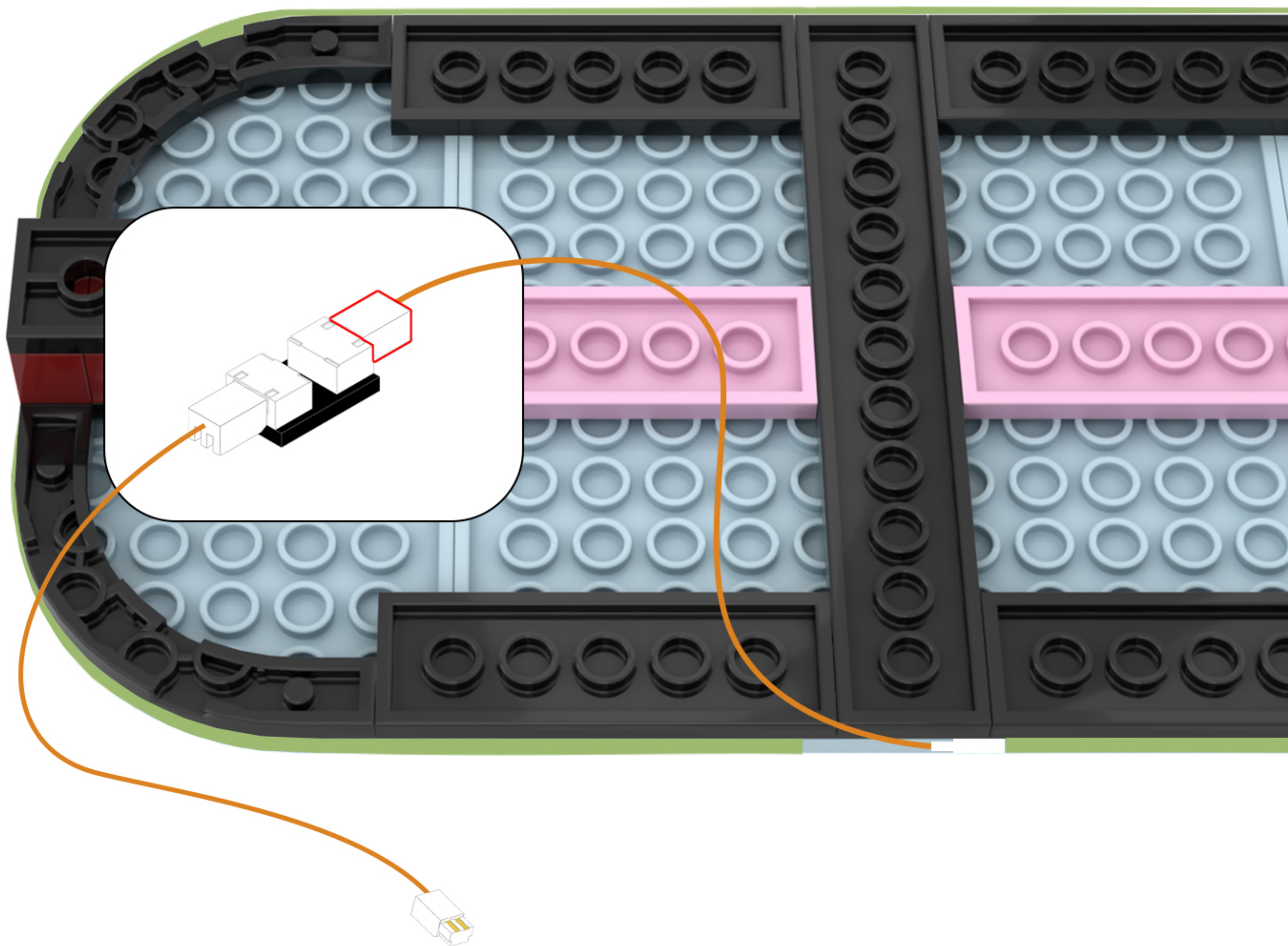
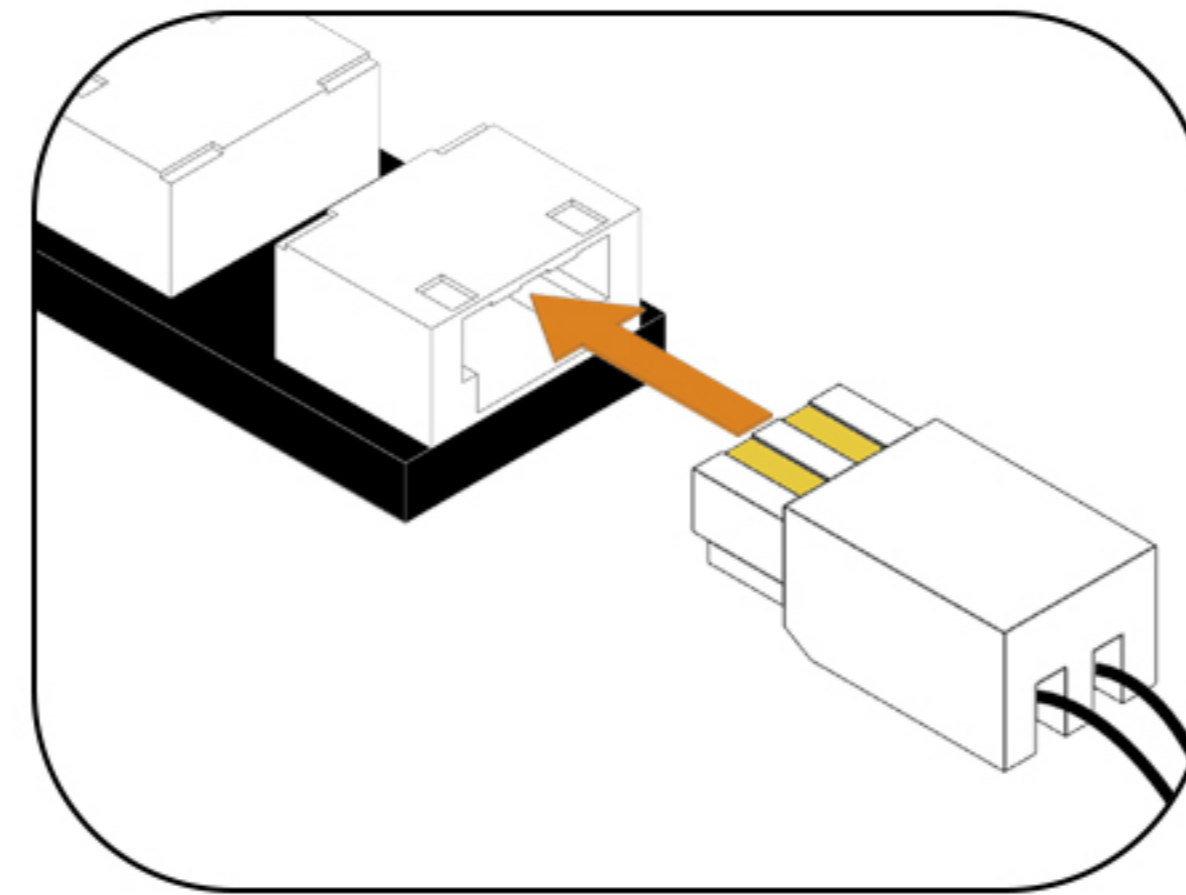

34

EN: Take the 1x2 baseplate from Bag 6, attach it to the brick, and make sure it covers the light cord.

DE: Nimm die 1x2-Grundplatte aus Beutel 6, befestige sie am Stein und achte darauf, dass sie das Lichtkabel verdeckt.

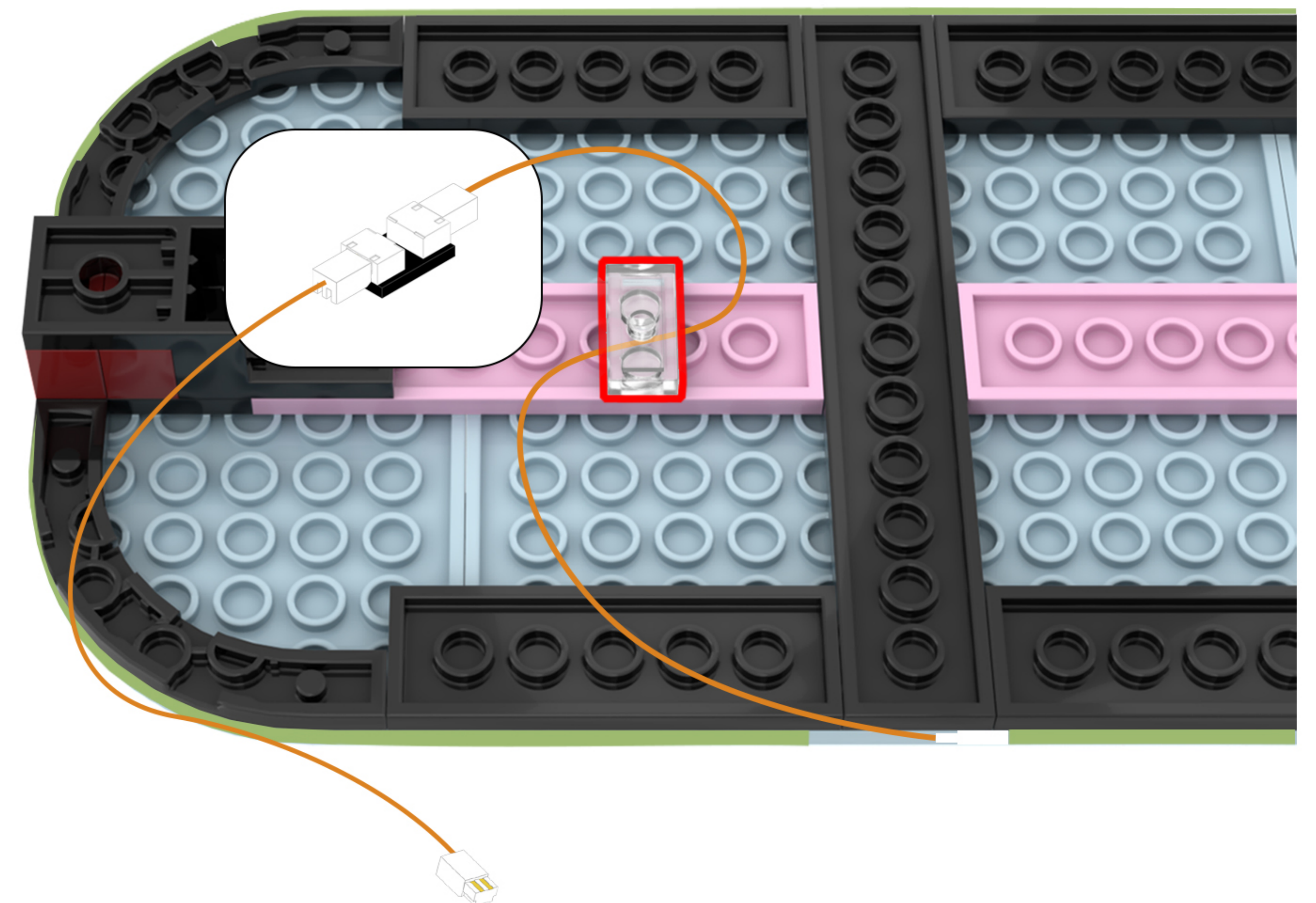
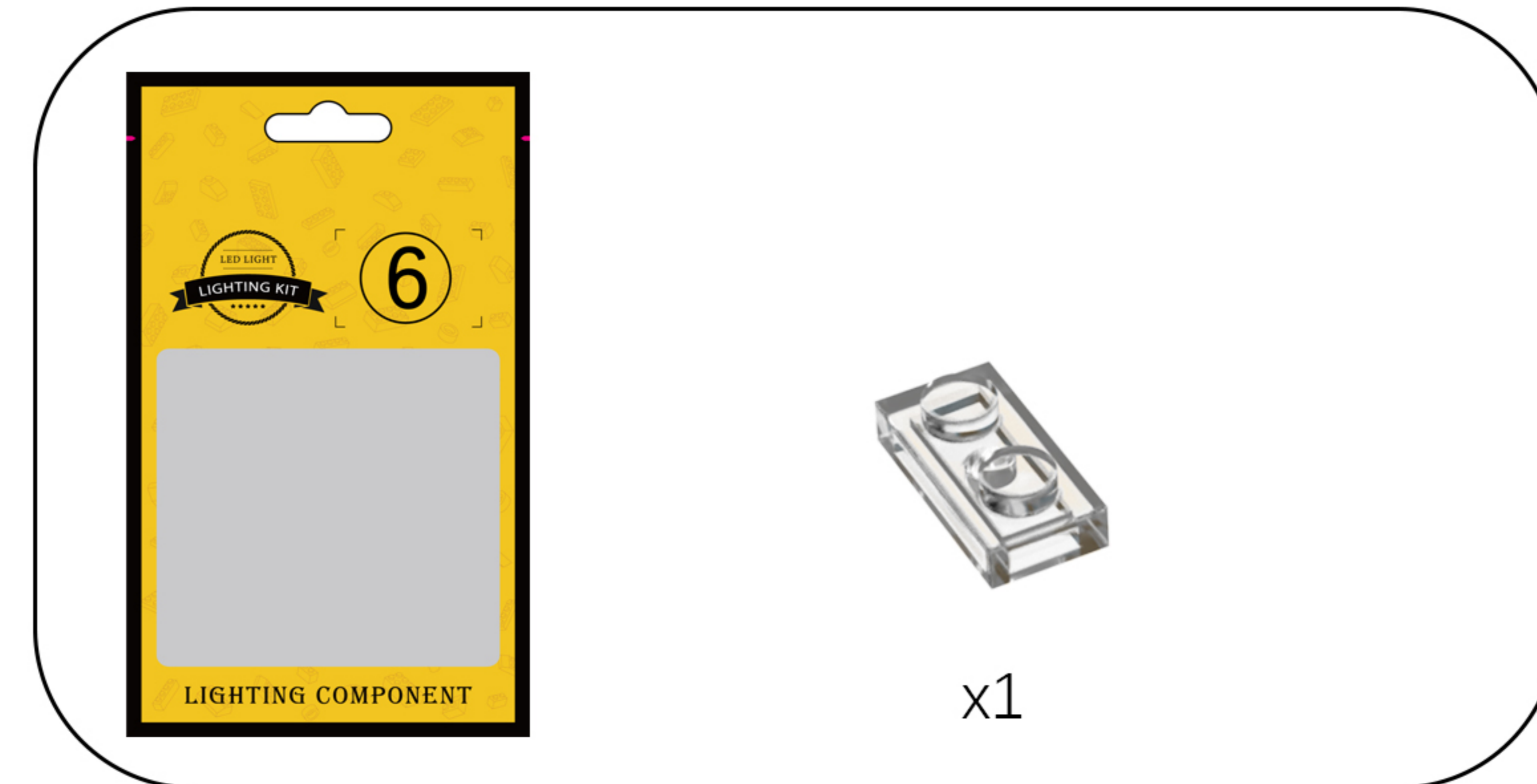

35

EN: Take out the building blocks with the lights attached and reassemble them in order.

DE: Nimm die Bausteine mit den daran befestigten Lichtern heraus und setze sie der Reihe nach wieder zusammen.

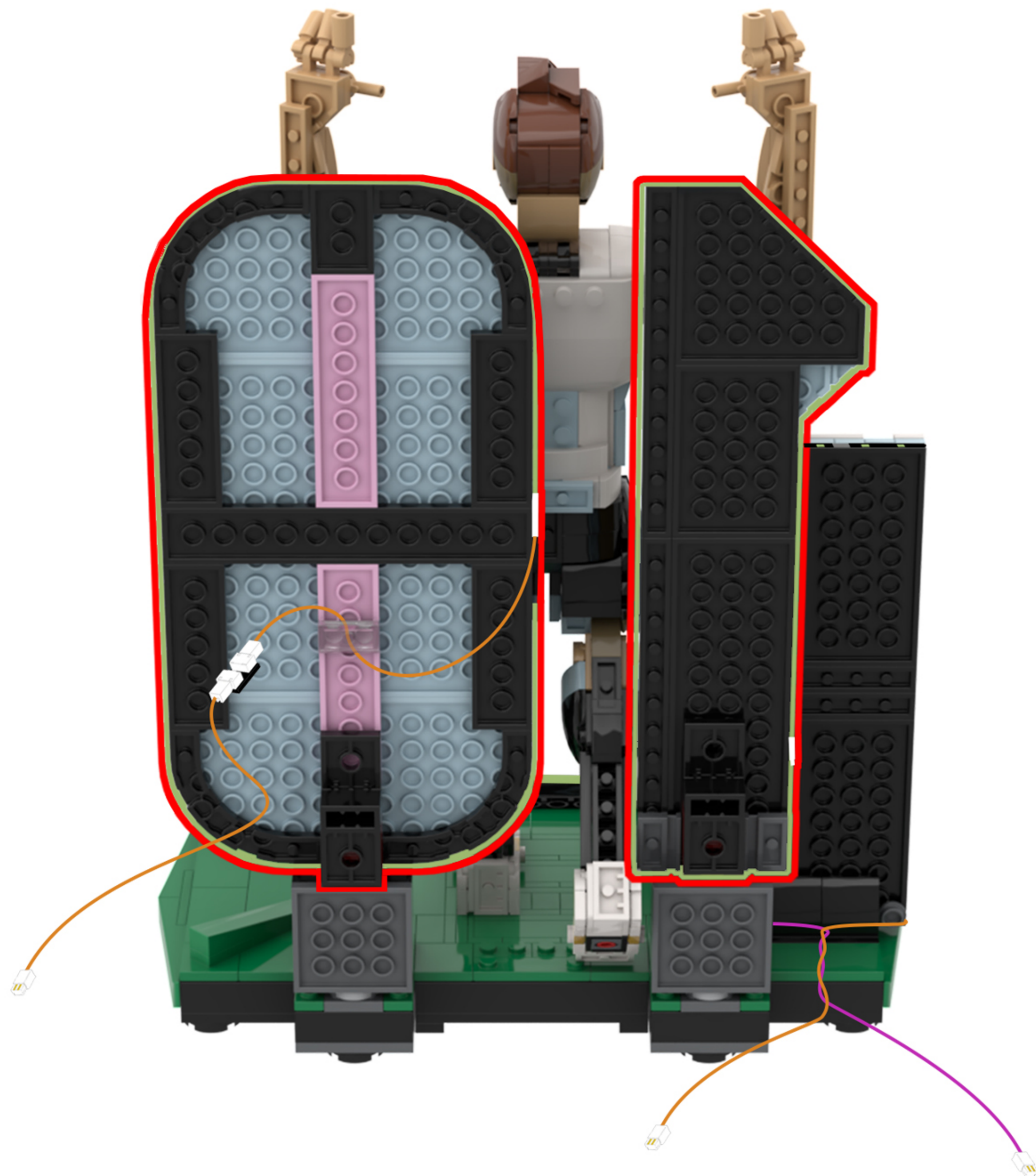
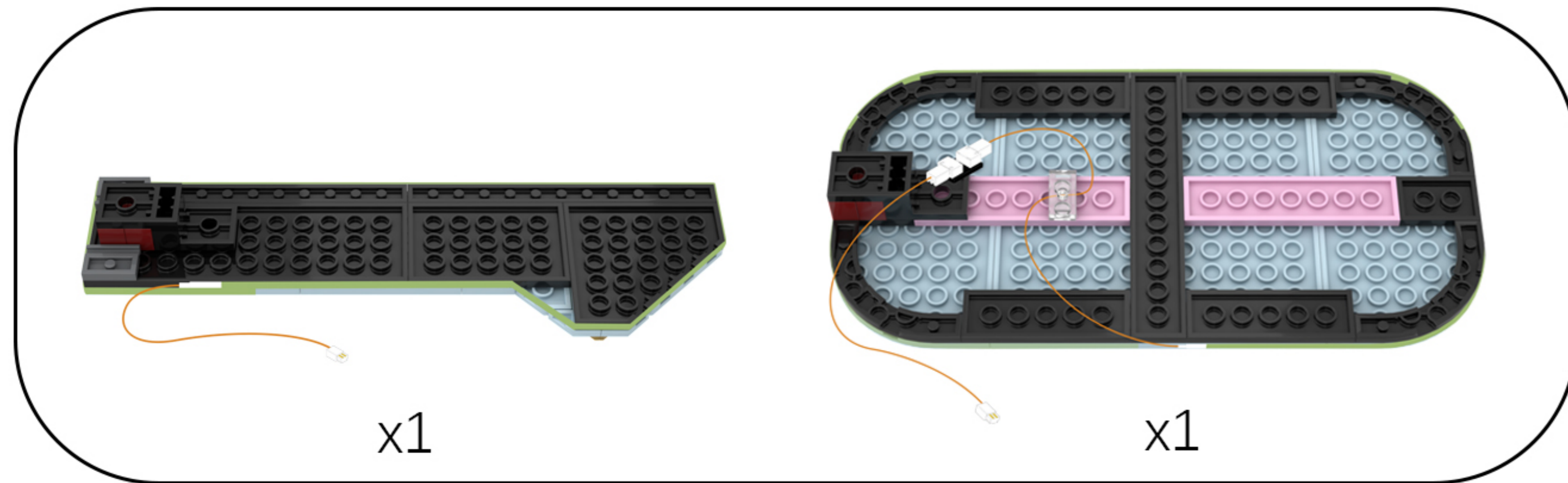

36

EN: Rotate the model to the front view.

DE: Drehen Sie das Modell in die Vorderansicht.

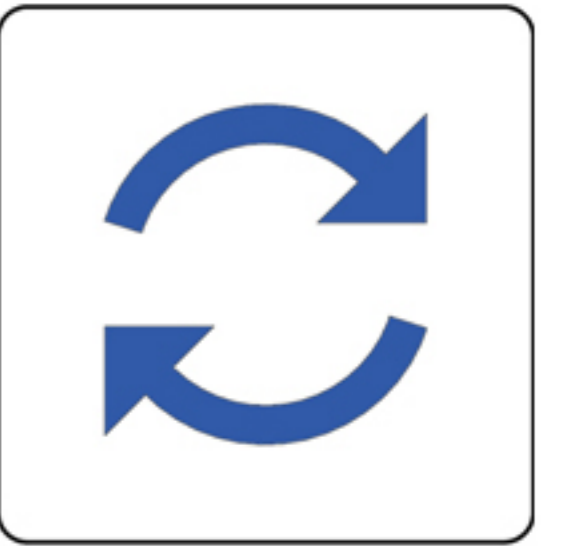

37

EN: Push the building block piece backward to separate the body from the left foot.

DE: Schieben Sie das Bausteinteil nach hinten, um den Körper vom linken Fuß zu trennen.

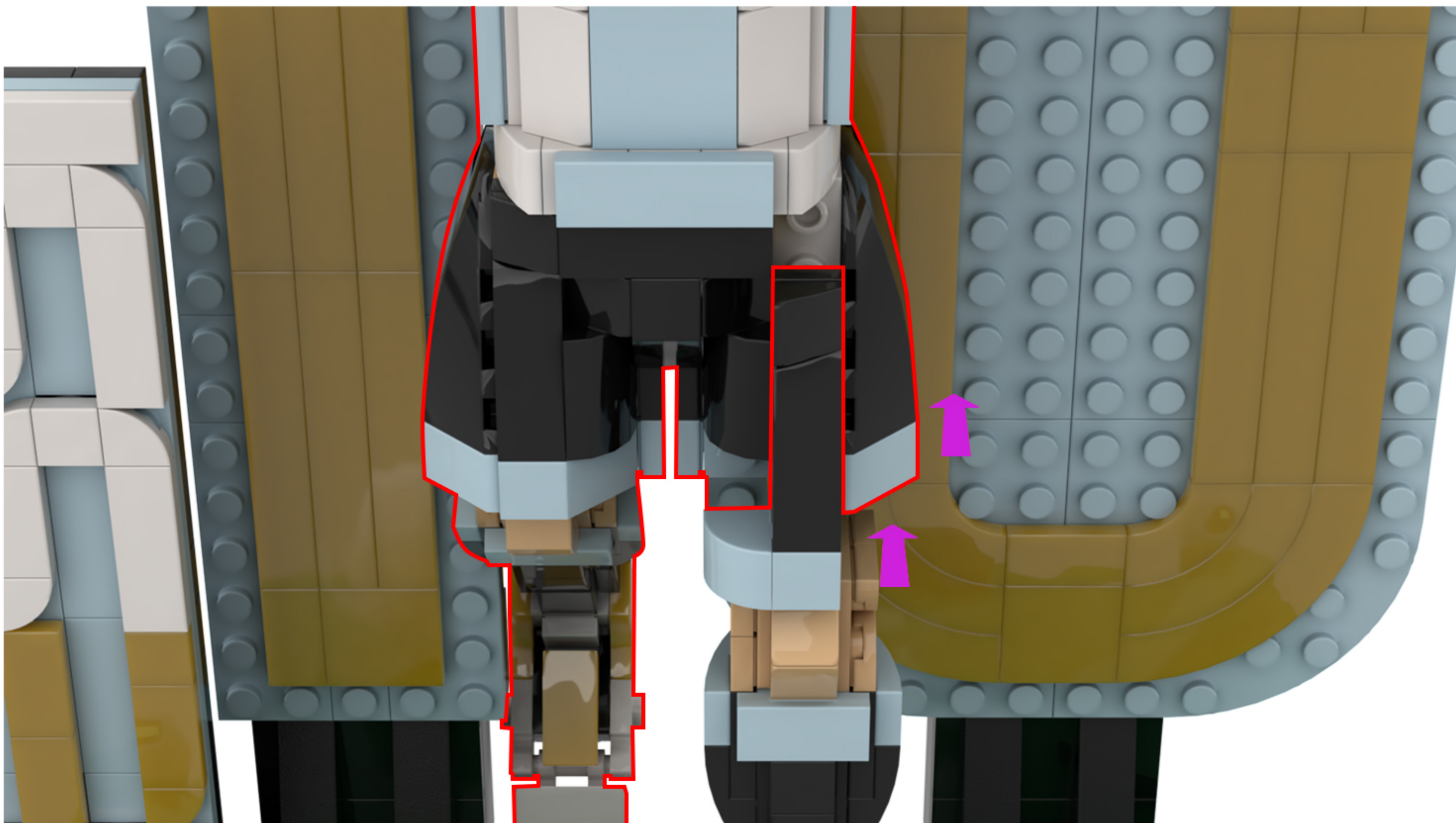
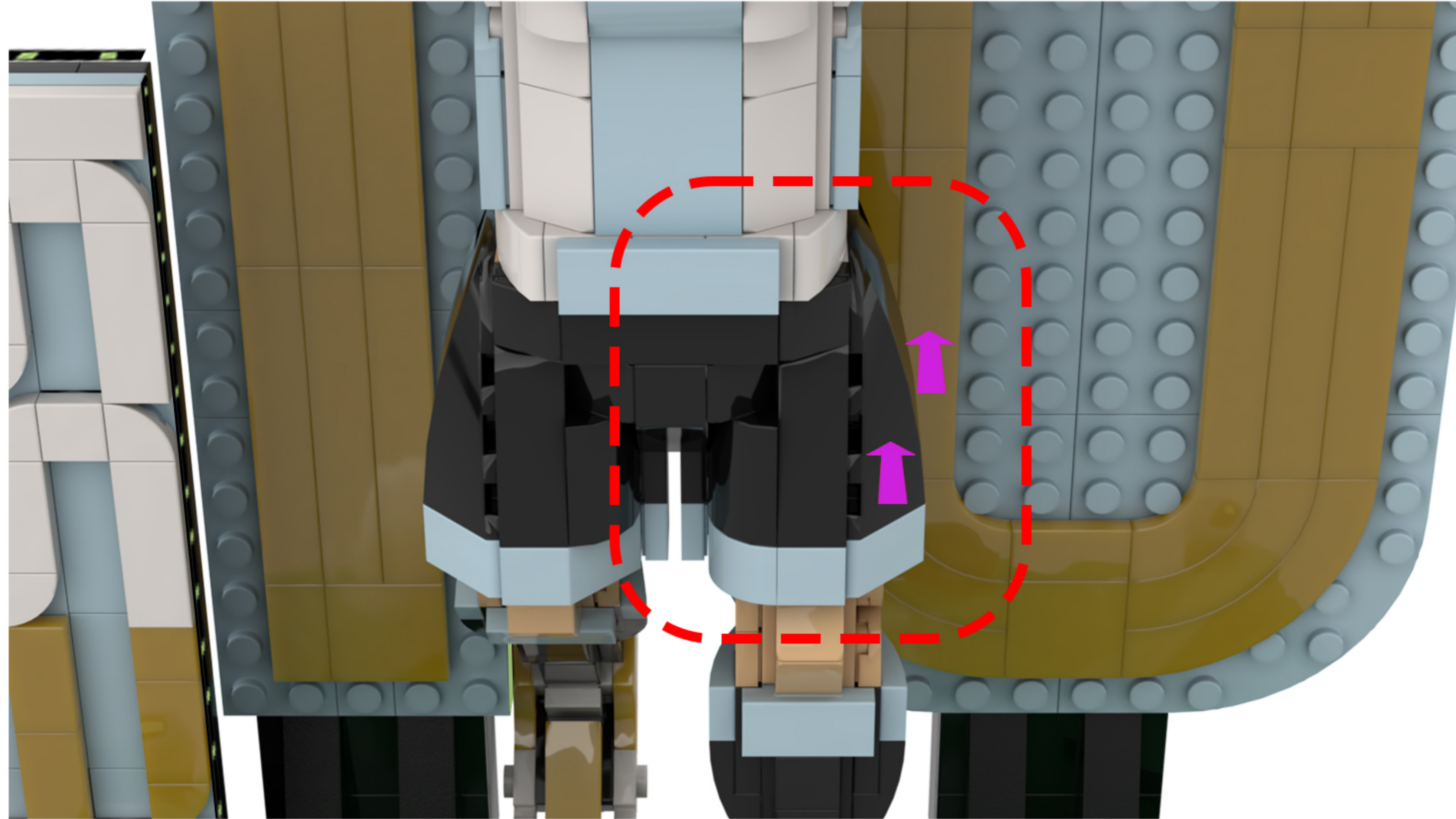

38

EN: As shown in the figure.

DE: Wie in der Abbildung dargestellt.

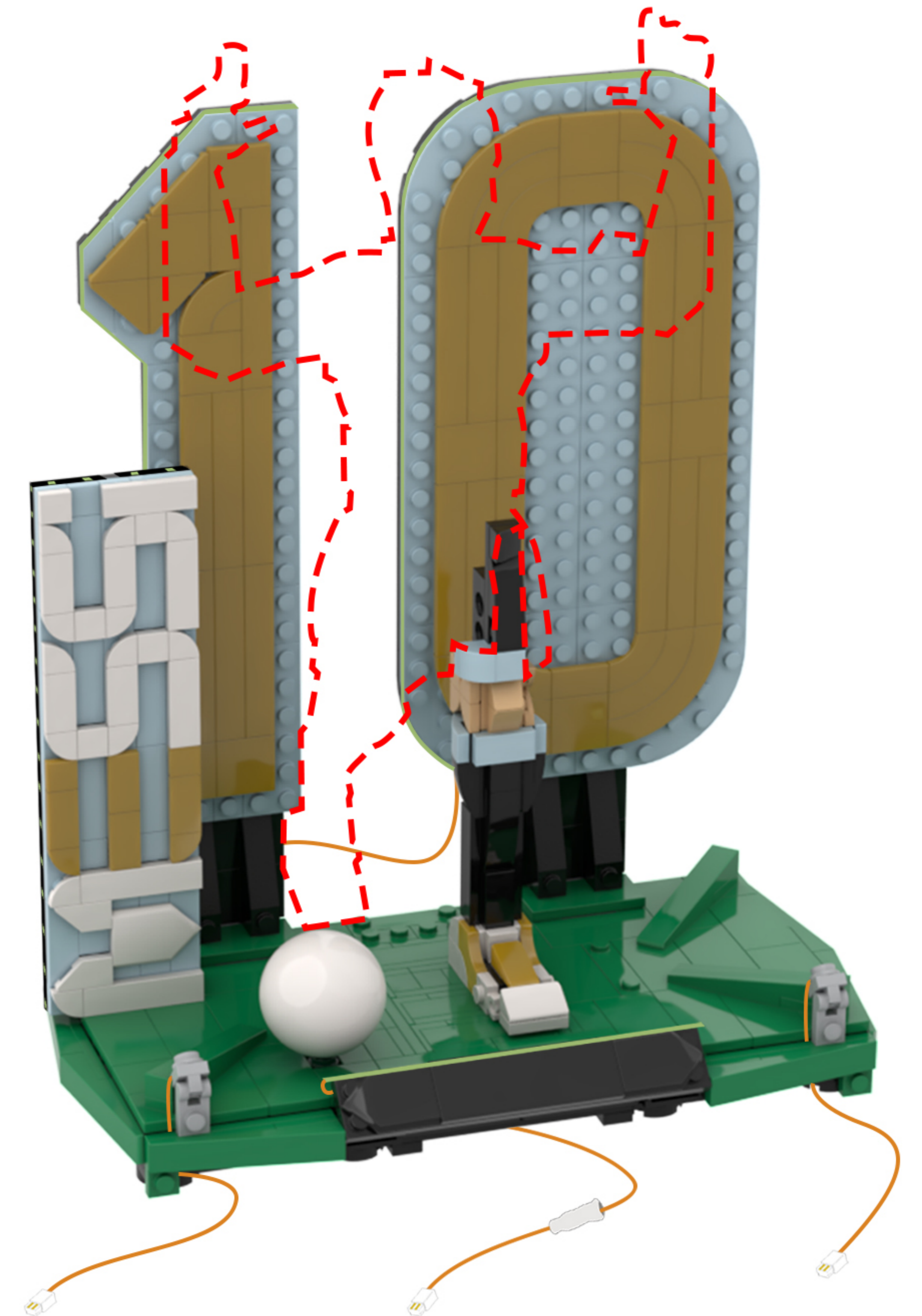

39

EN: Place the model flat on a surface as shown in the figure, and locate the three light cords for the decorative lights shown in the figure.

DE: Legen Sie das Modell wie in der Abbildung gezeigt flach auf eine Unterlage und suchen Sie die drei Kabel für die in der Abbildung gezeigten Dekorationslichter.

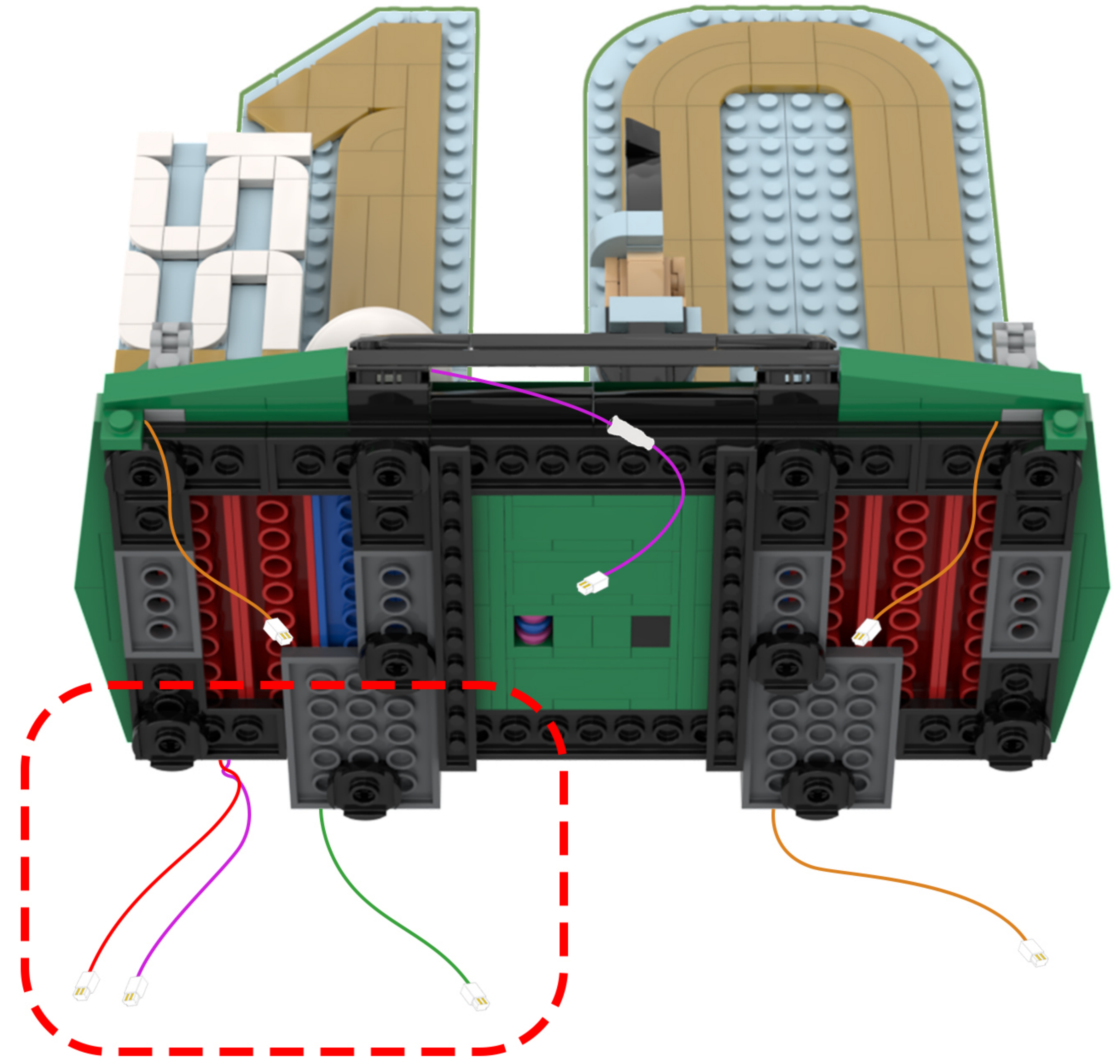
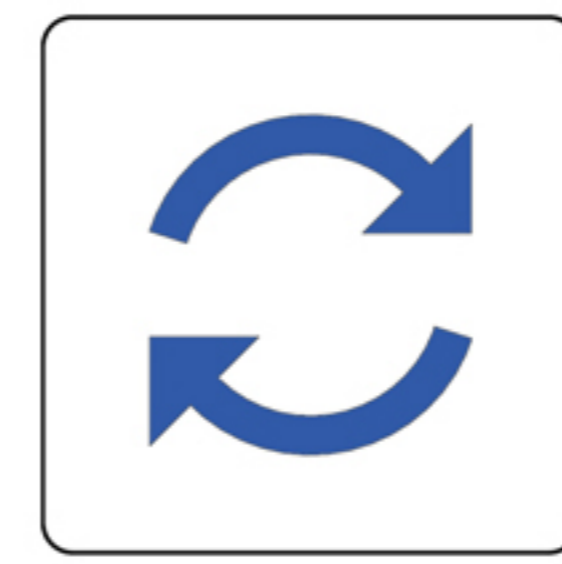

40

EN: Take the expansion board and the connecting cable out of Bag 3 and connect them together.

DE: Nehmen Sie die Erweiterungskarte und das Verbindungskabel aus Beutel 3 und verbinden Sie beide miteinander.

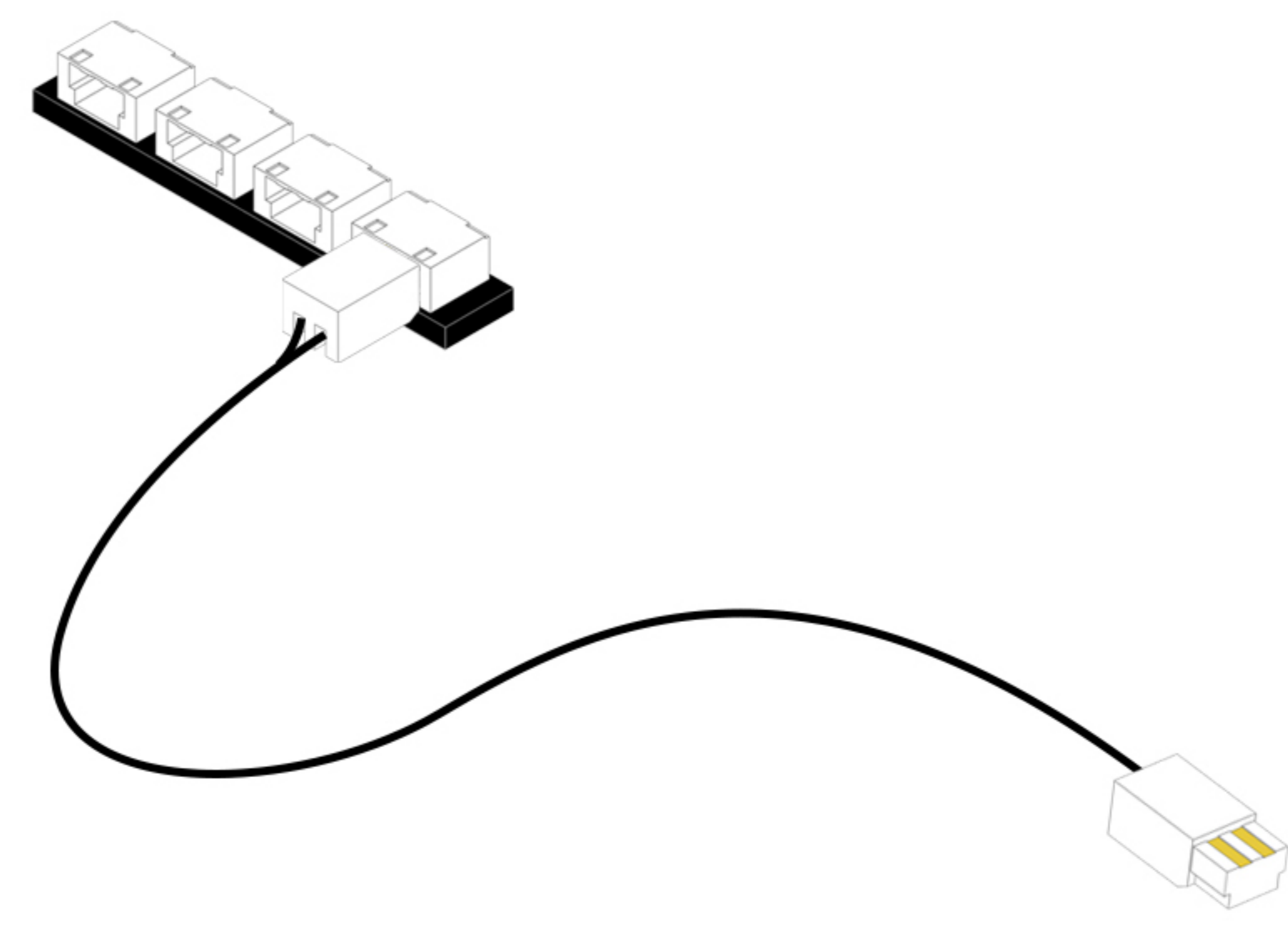
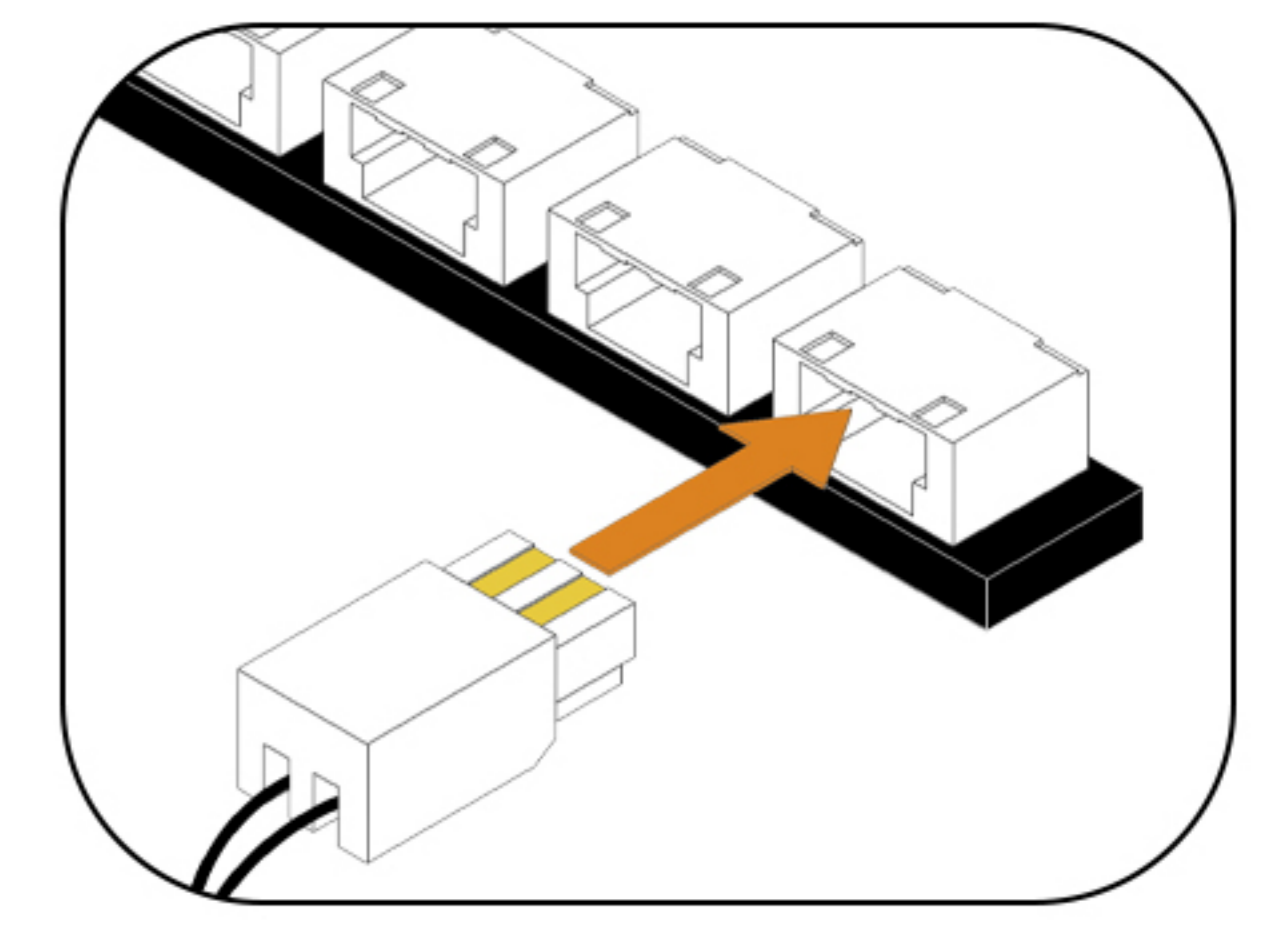
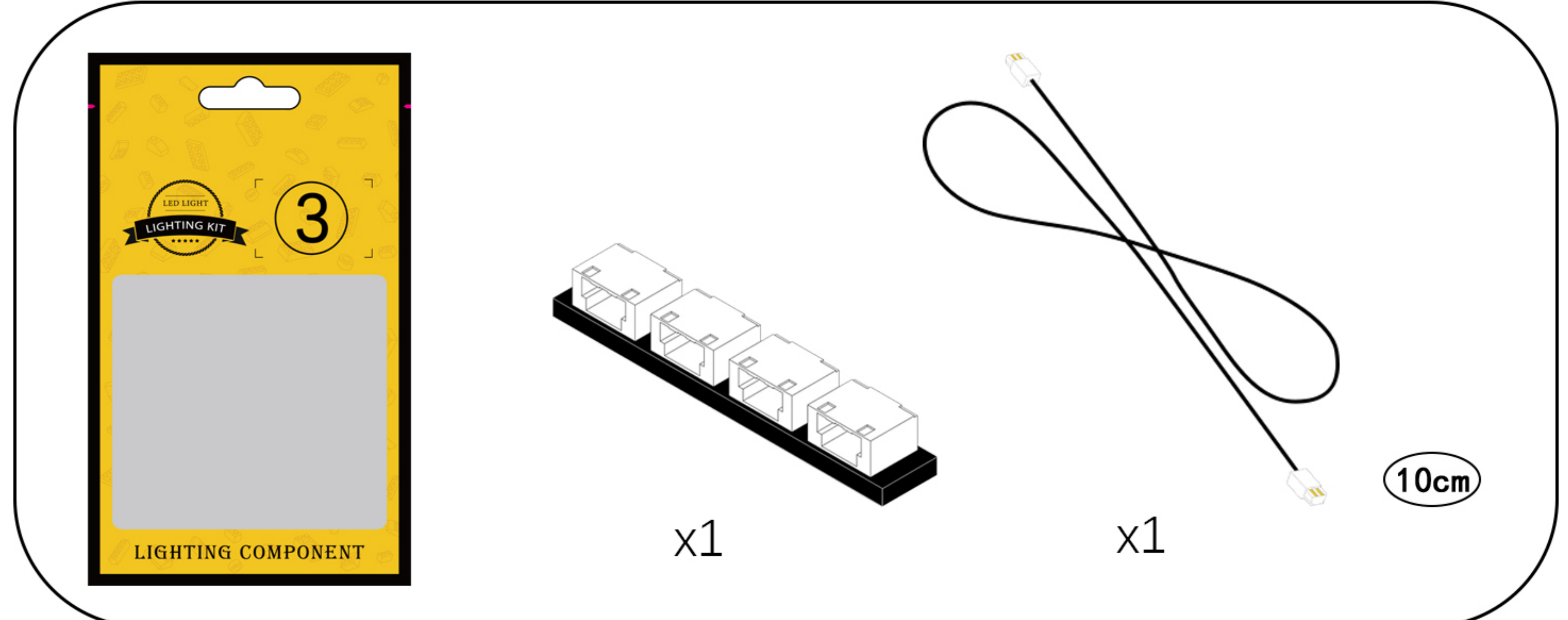

41

EN: Connect the three light cables to the expansion board in sequence.

DE: Schließen Sie die drei Lichtkabel nacheinander an die Erweiterungskarte an.

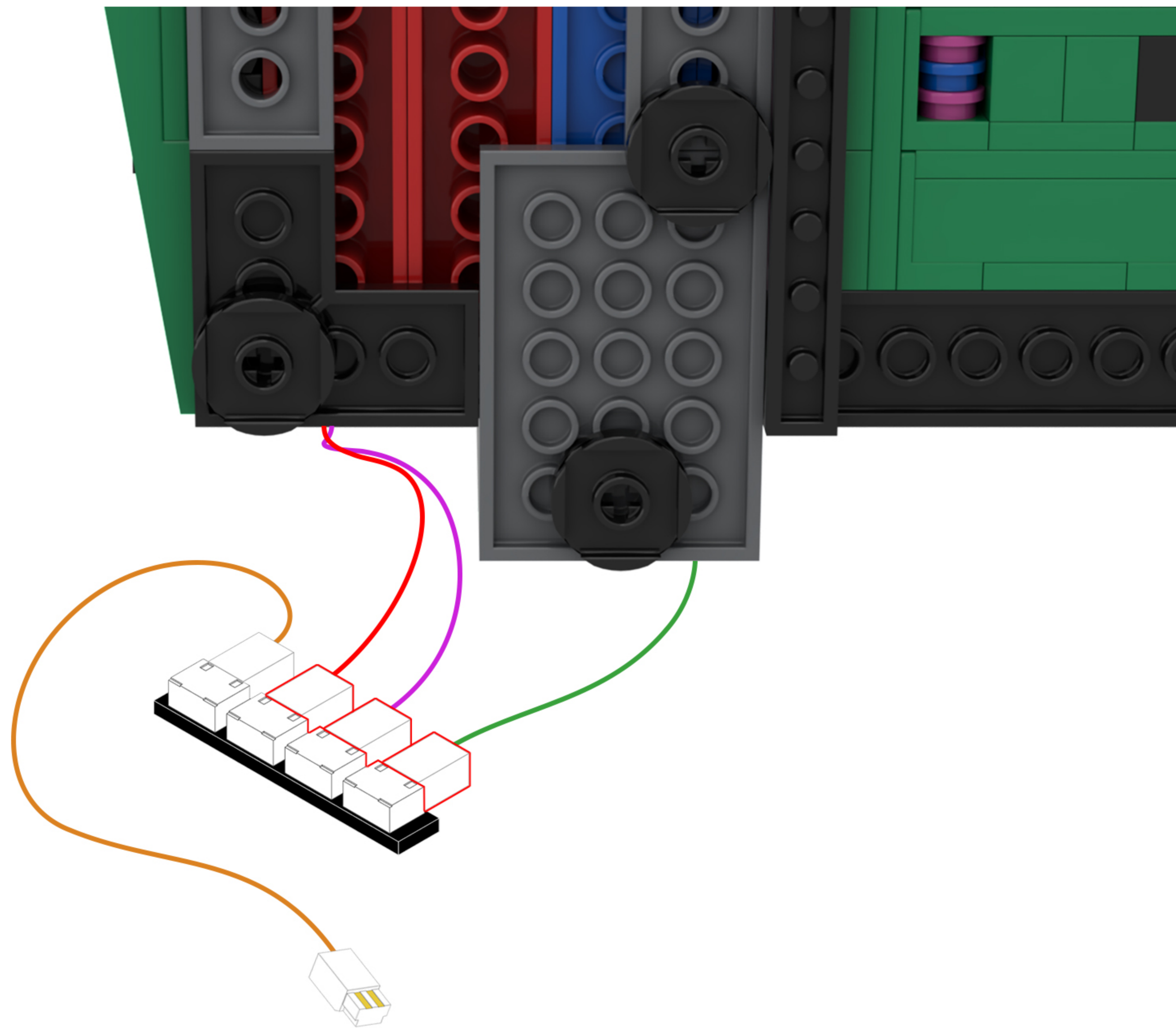
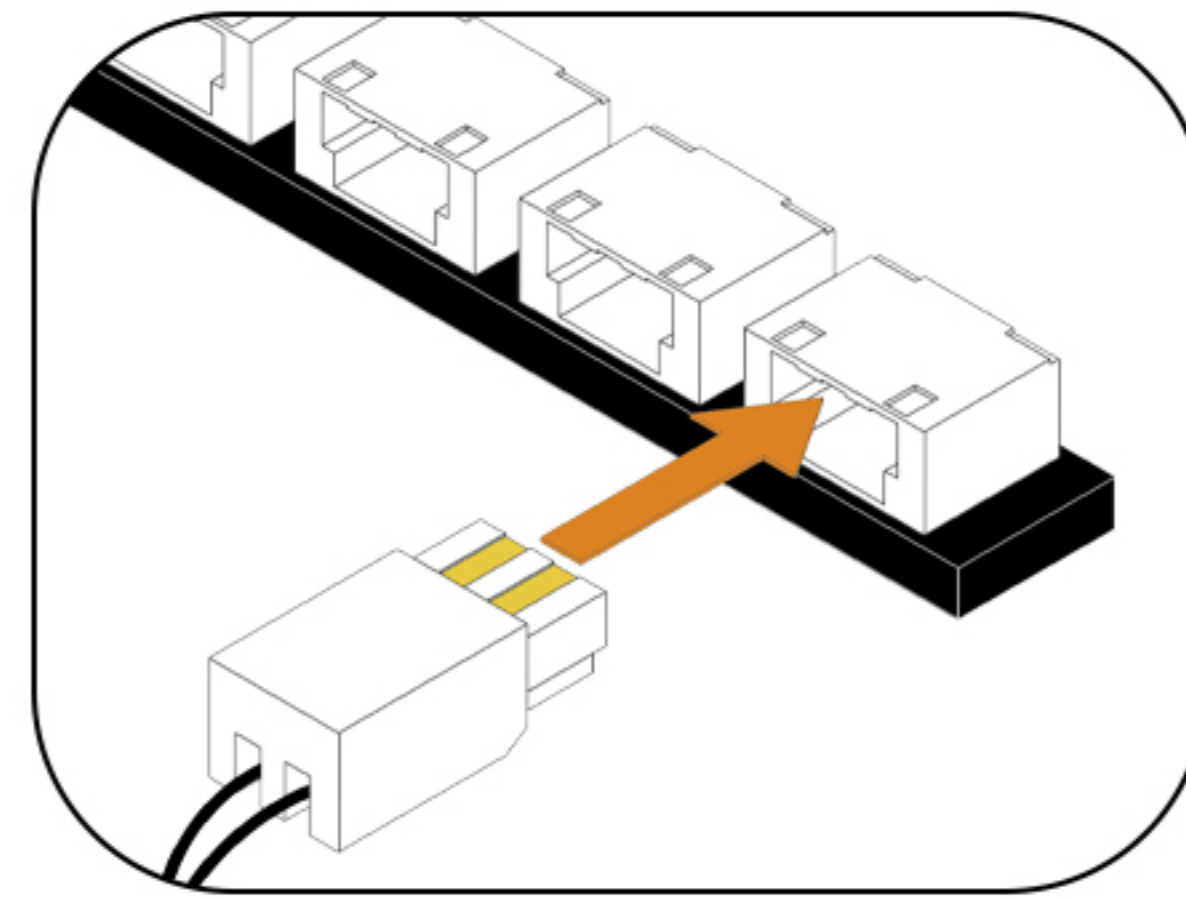

42

EN: Peel off the adhesive backing of the expansion board and attach it to the location shown in the illustration.

DE: Entfernen Sie die Schutzfolie von der Rückseite der Erweiterungsplatte und kleben Sie sie an die in der Abbildung gezeigte Stelle.

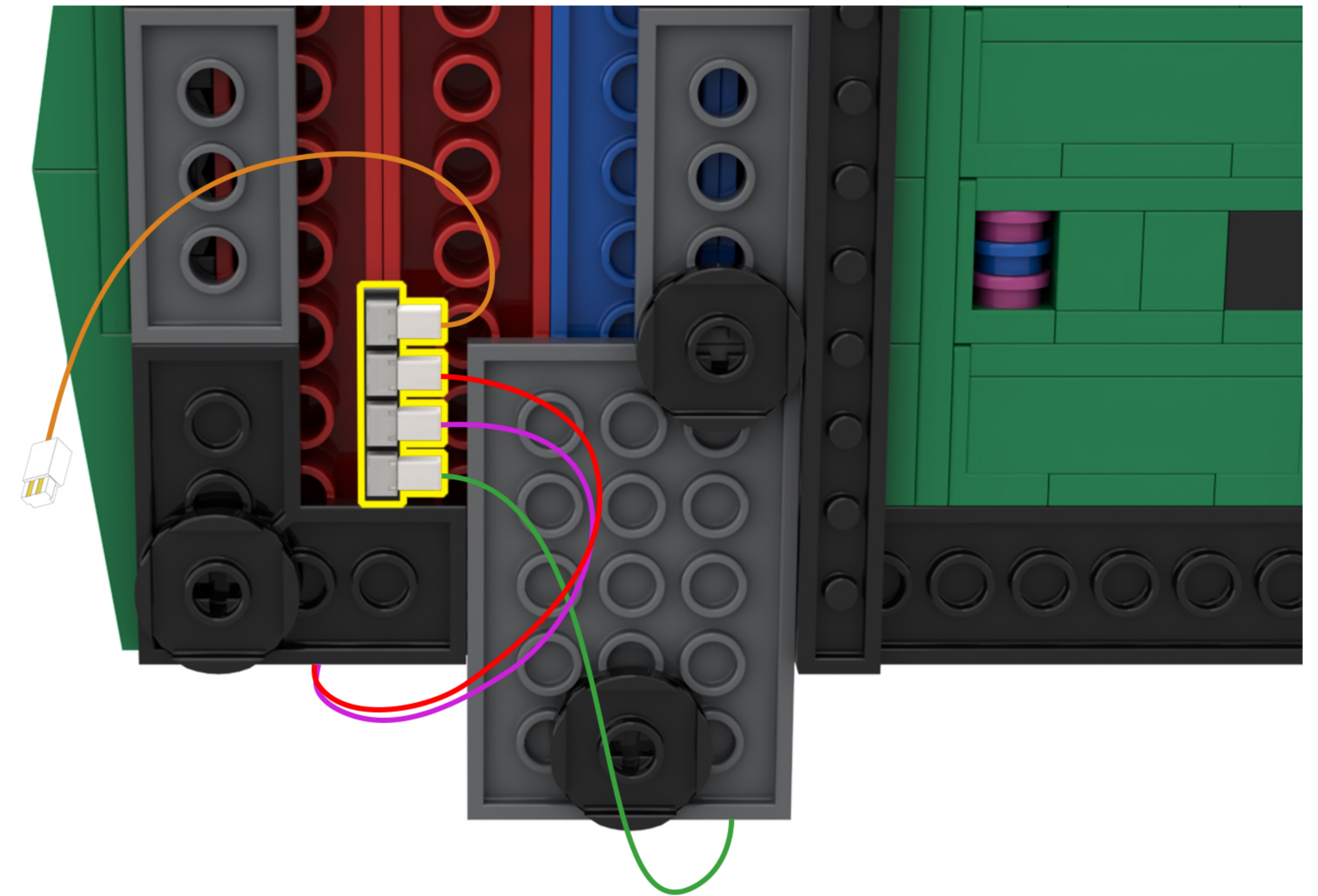

43

EN: Locate the two light wires in the diagram.

DE: Suchen Sie die beiden Lichtkabel in der Abbildung.

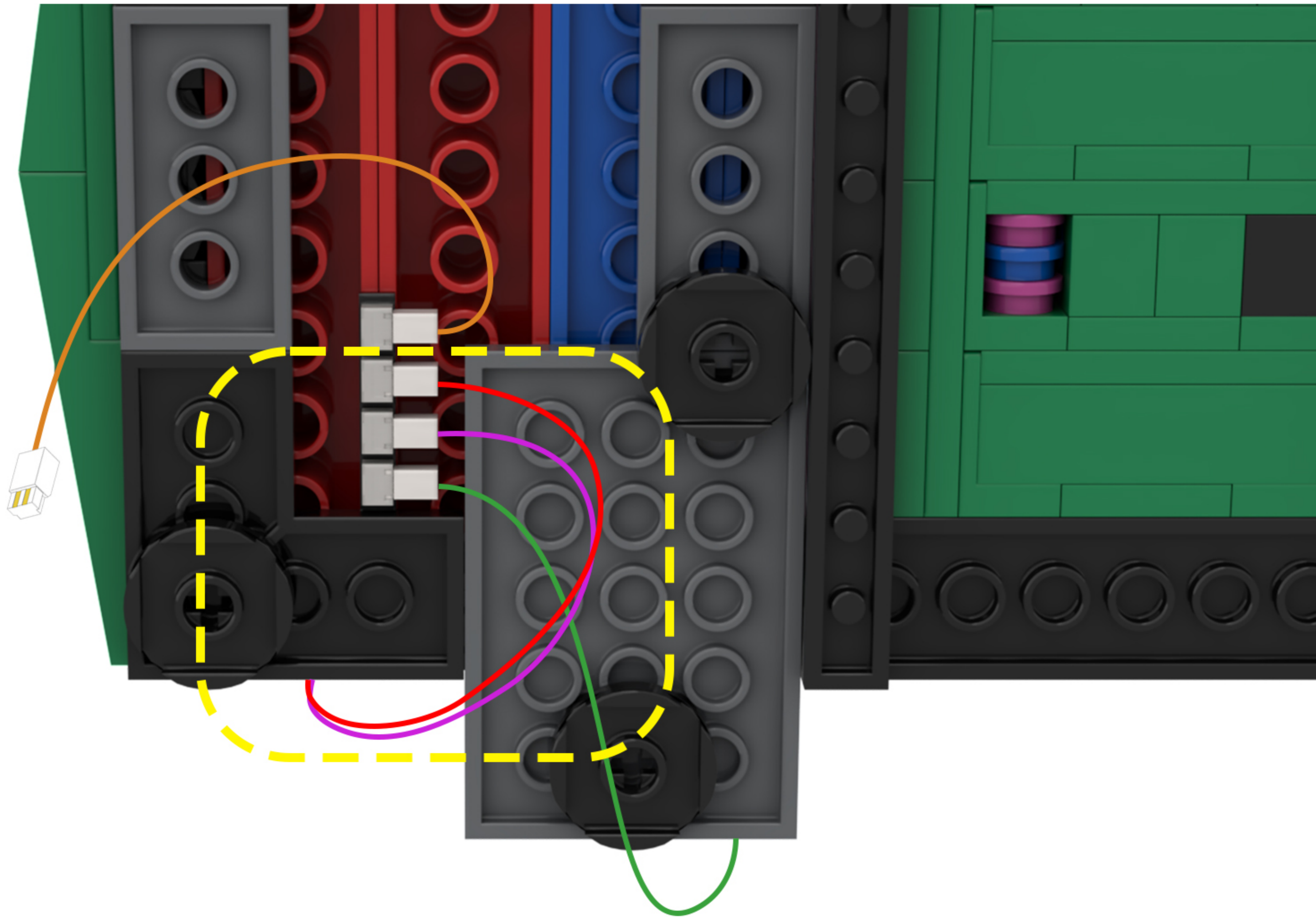

44

EN: Arrange the two strands of lights as shown in the figure.

DE: Ordnen Sie die beiden Lichterketten wie in der Abbildung gezeigt an.

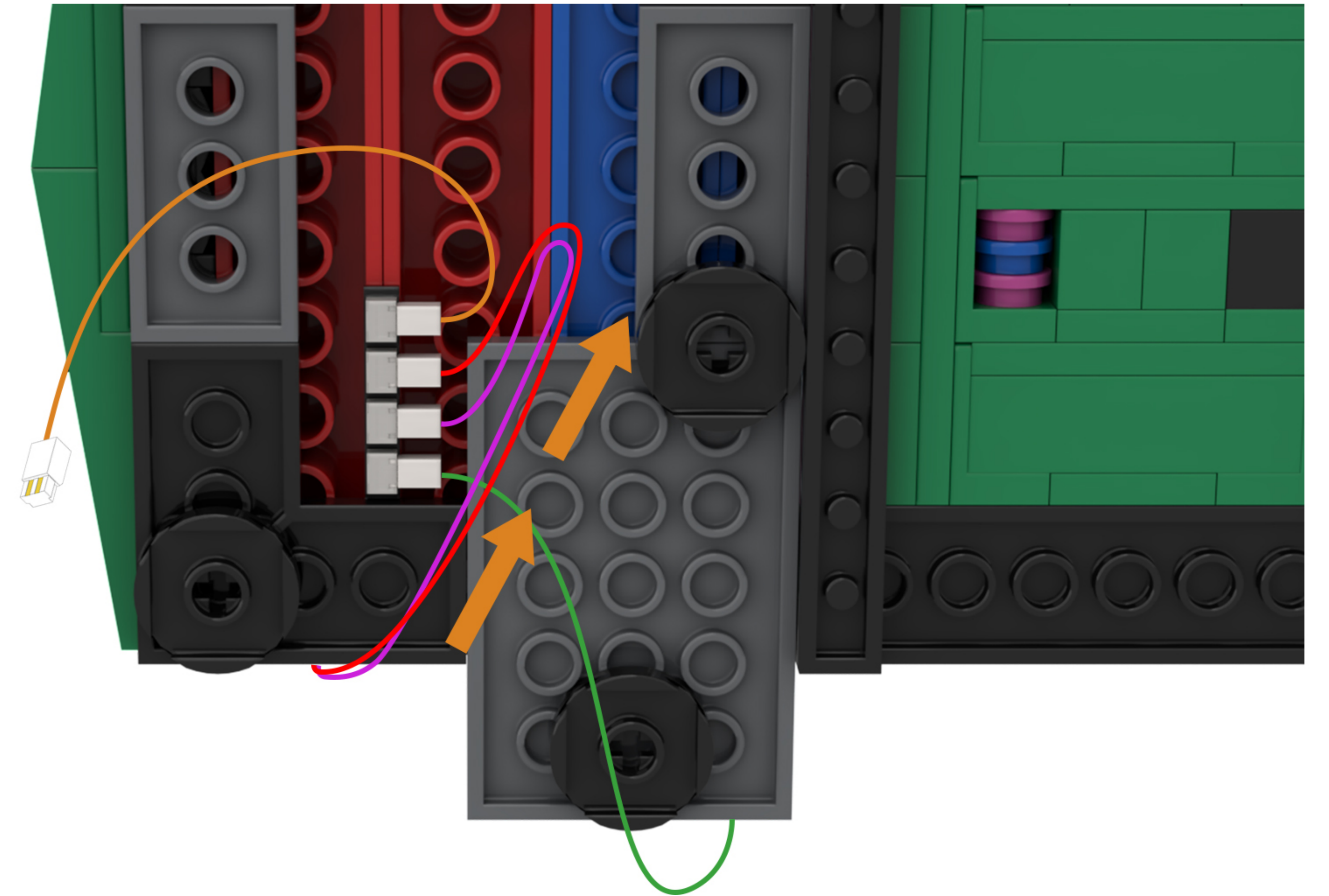

**45** EN: Split as shown in the figure.  
DE: Wie in der Abbildung gezeigt, teilen Sie es auf.

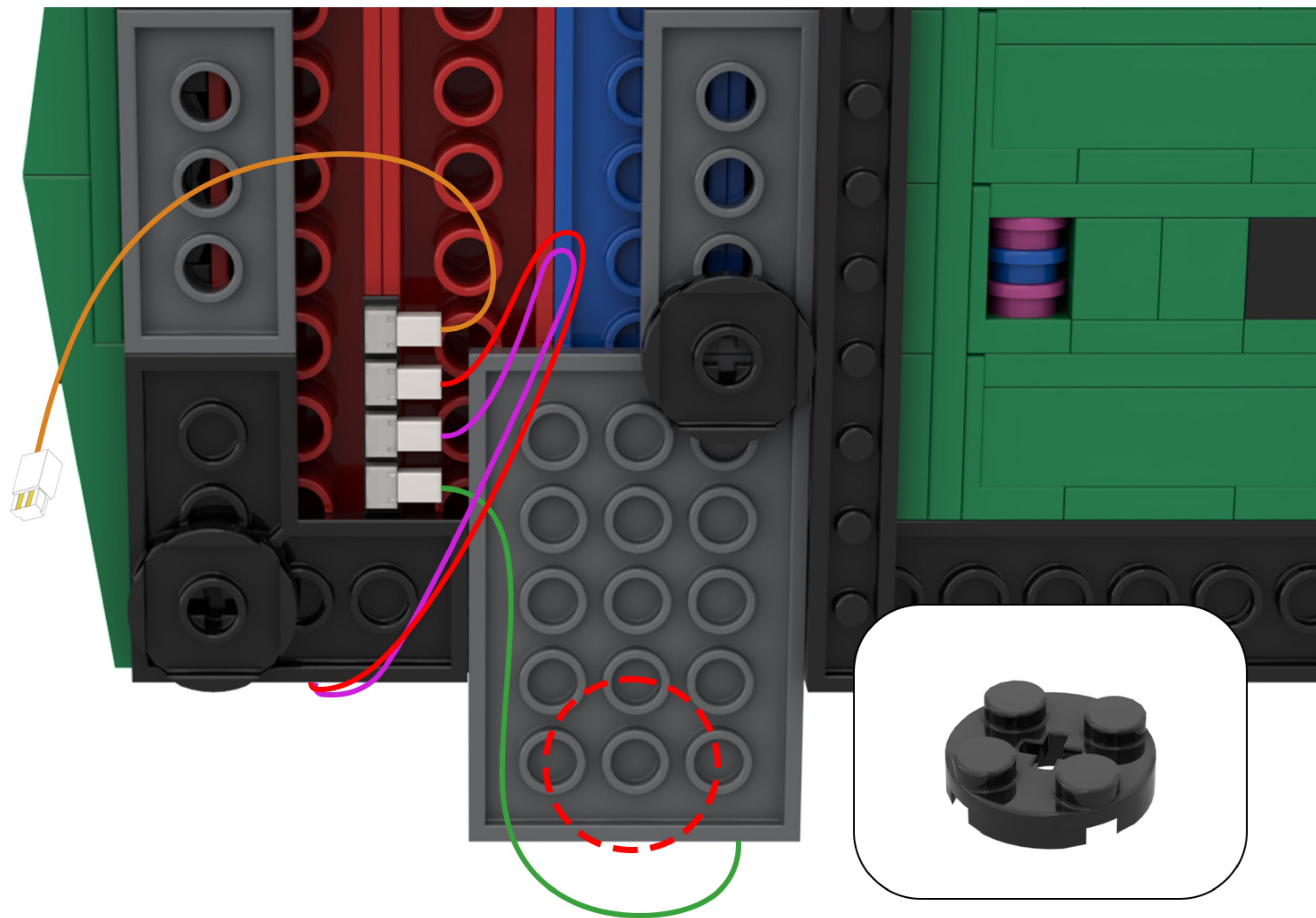

**46** EN: Arrange the lighting lines according to the diagram.  
DE: Ordnen Sie die Beleuchtungslinien gemäß der Abbildung an.

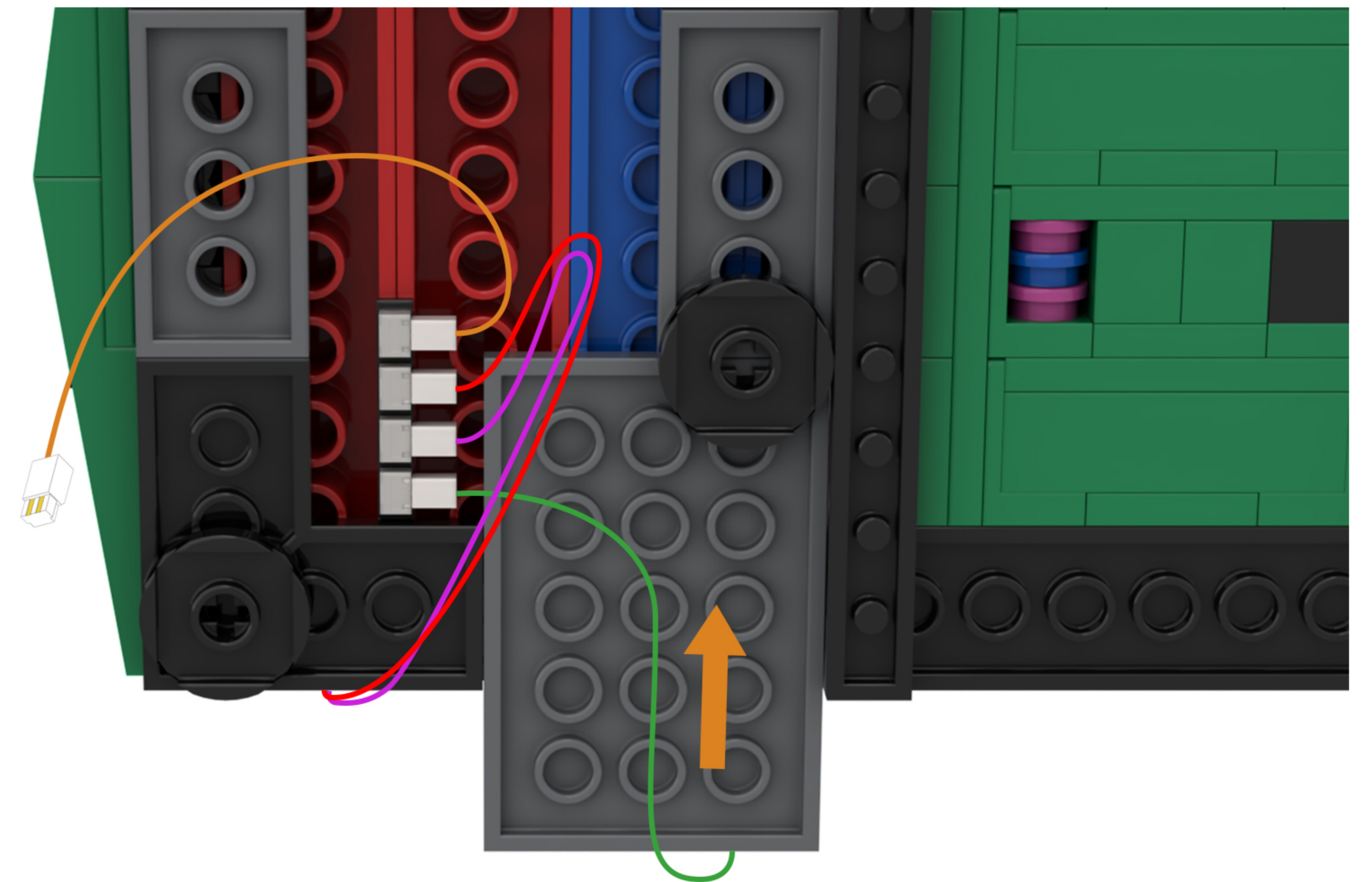

47

EN: Take out the disassembled building blocks, reassemble them, and secure the light cord.

DE: Nehmen Sie die zerlegten Bausteine heraus, setzen Sie sie wieder zusammen und befestigen Sie das Lichtkabel.

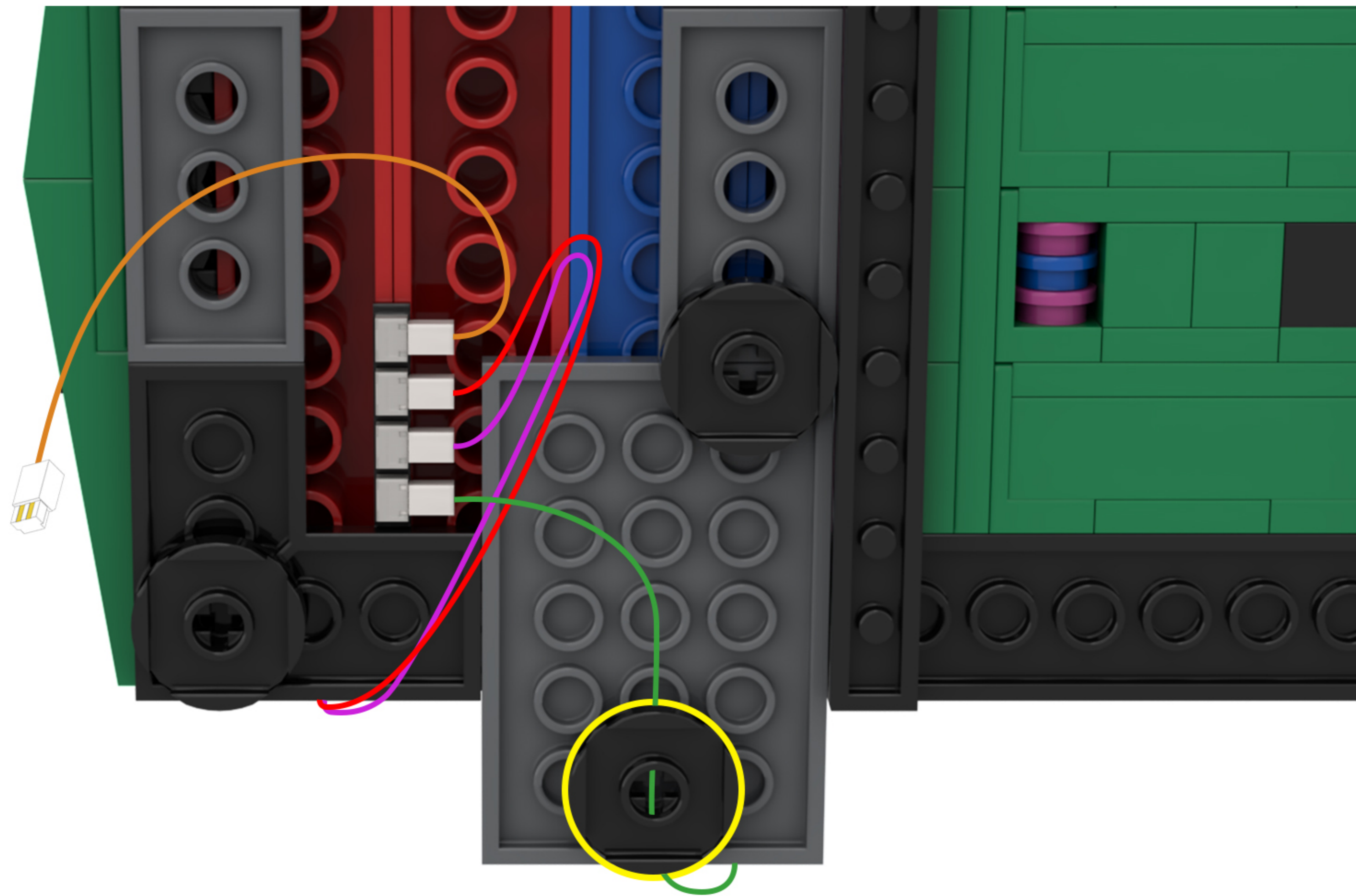
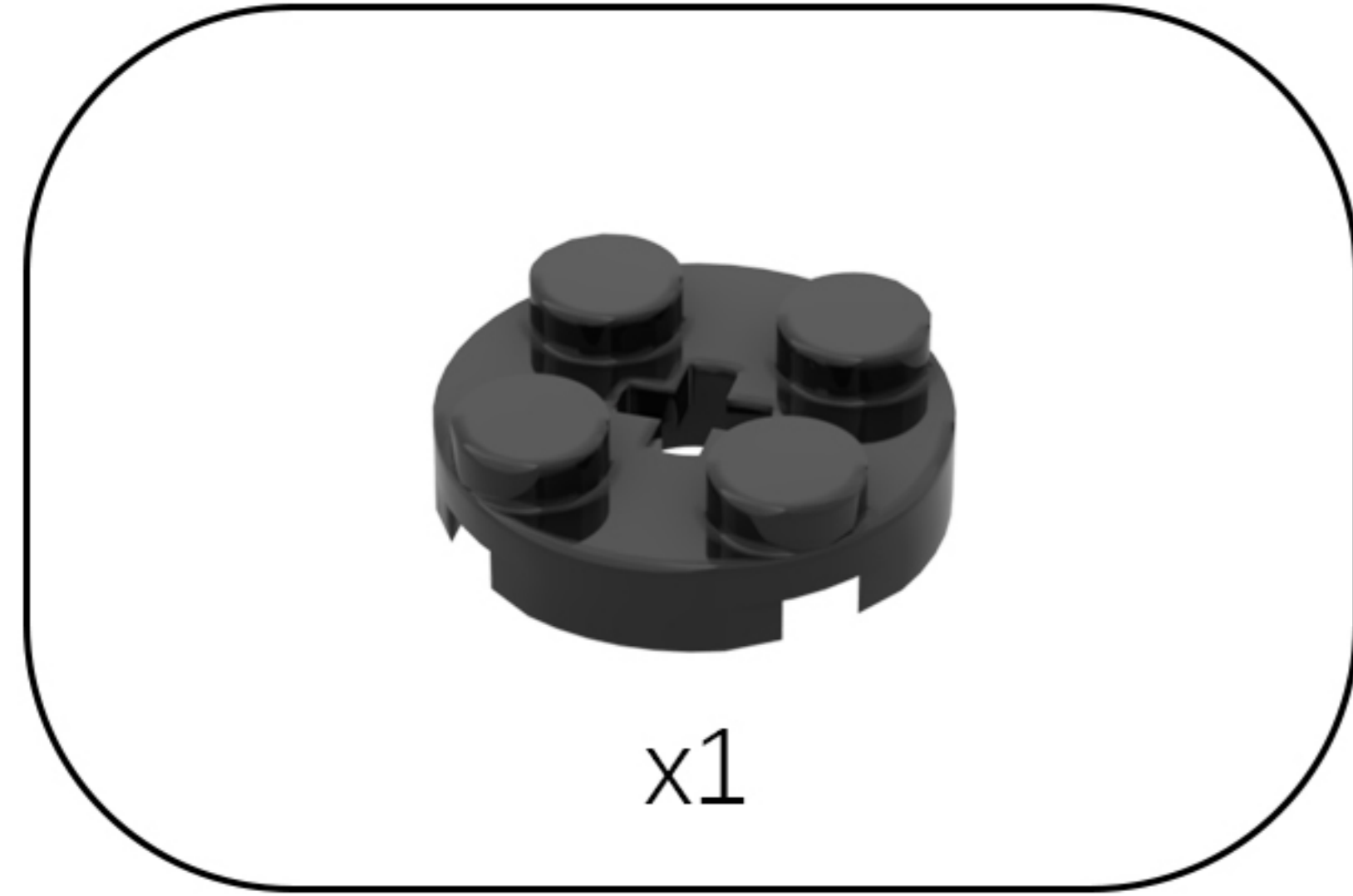

48

EN: Go to the other side of the model.

DE: Geh auf die andere Seite des Modells.

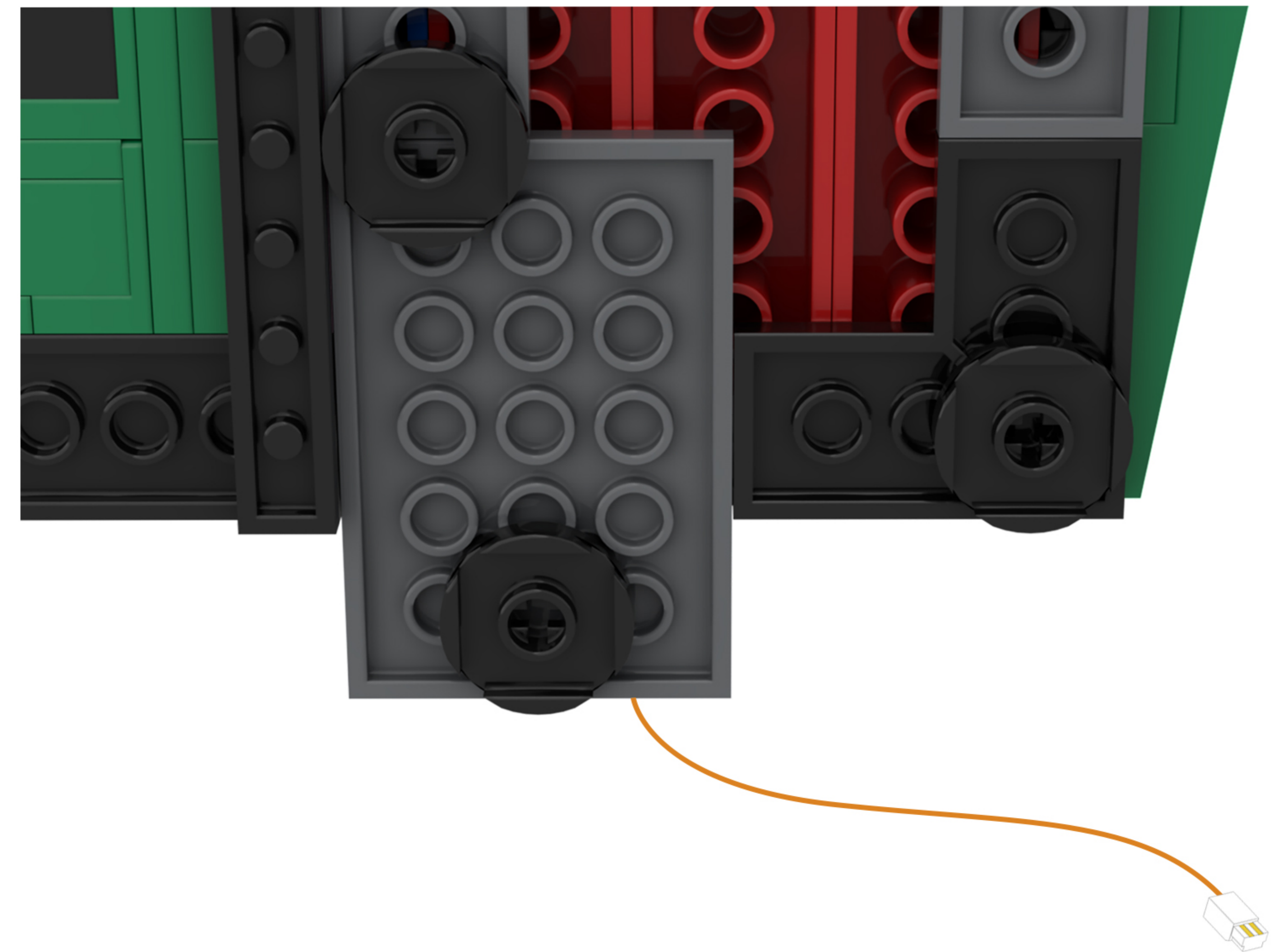

**49** EN: Split as shown in the figure.  
DE: Wie in der Abbildung gezeigt, teilen Sie es auf.

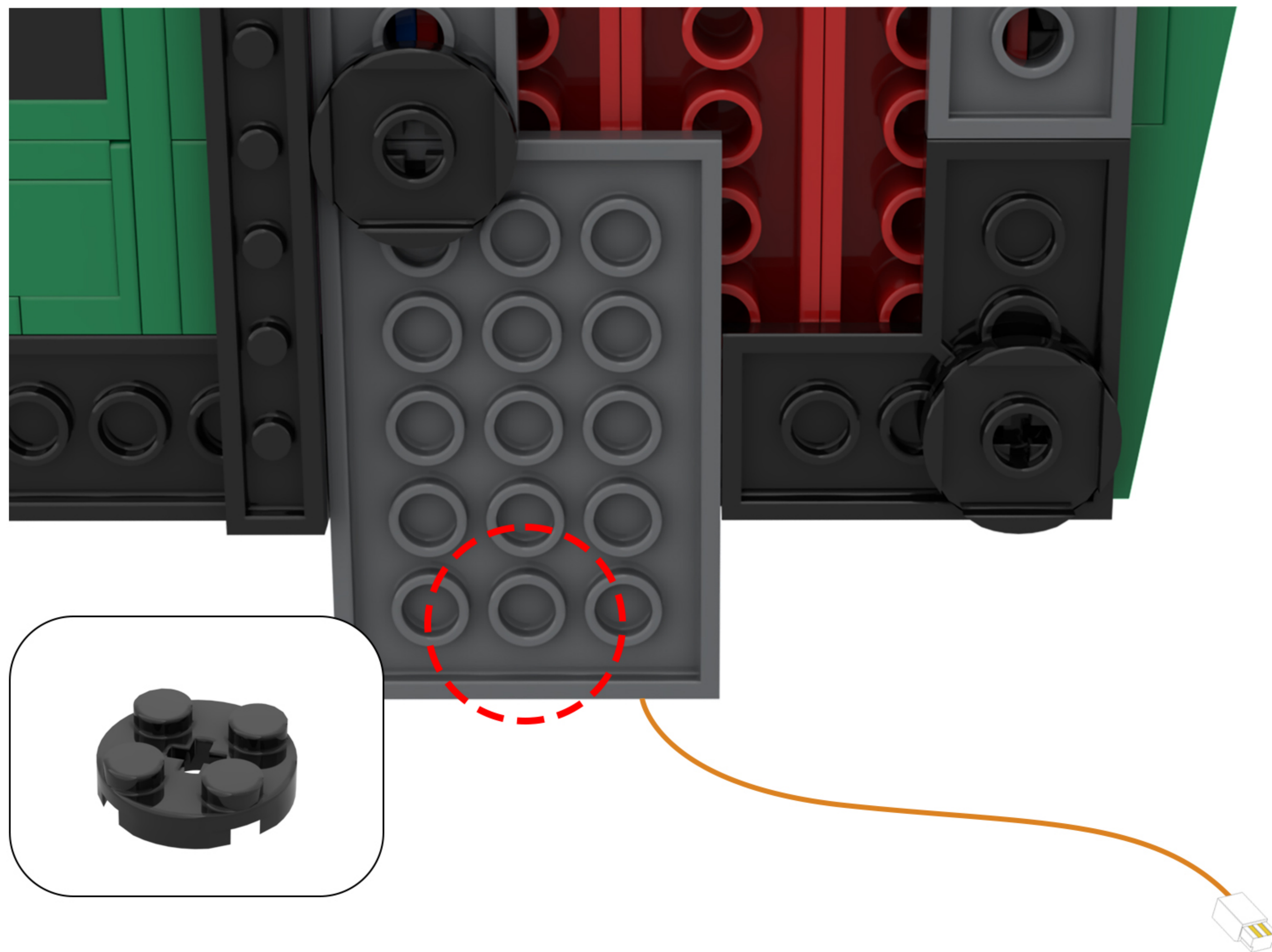

**50** EN: Arrange the lighting lines according to the diagram.  
DE: Ordnen Sie die Beleuchtungslinien gemäß der Abbildung an.

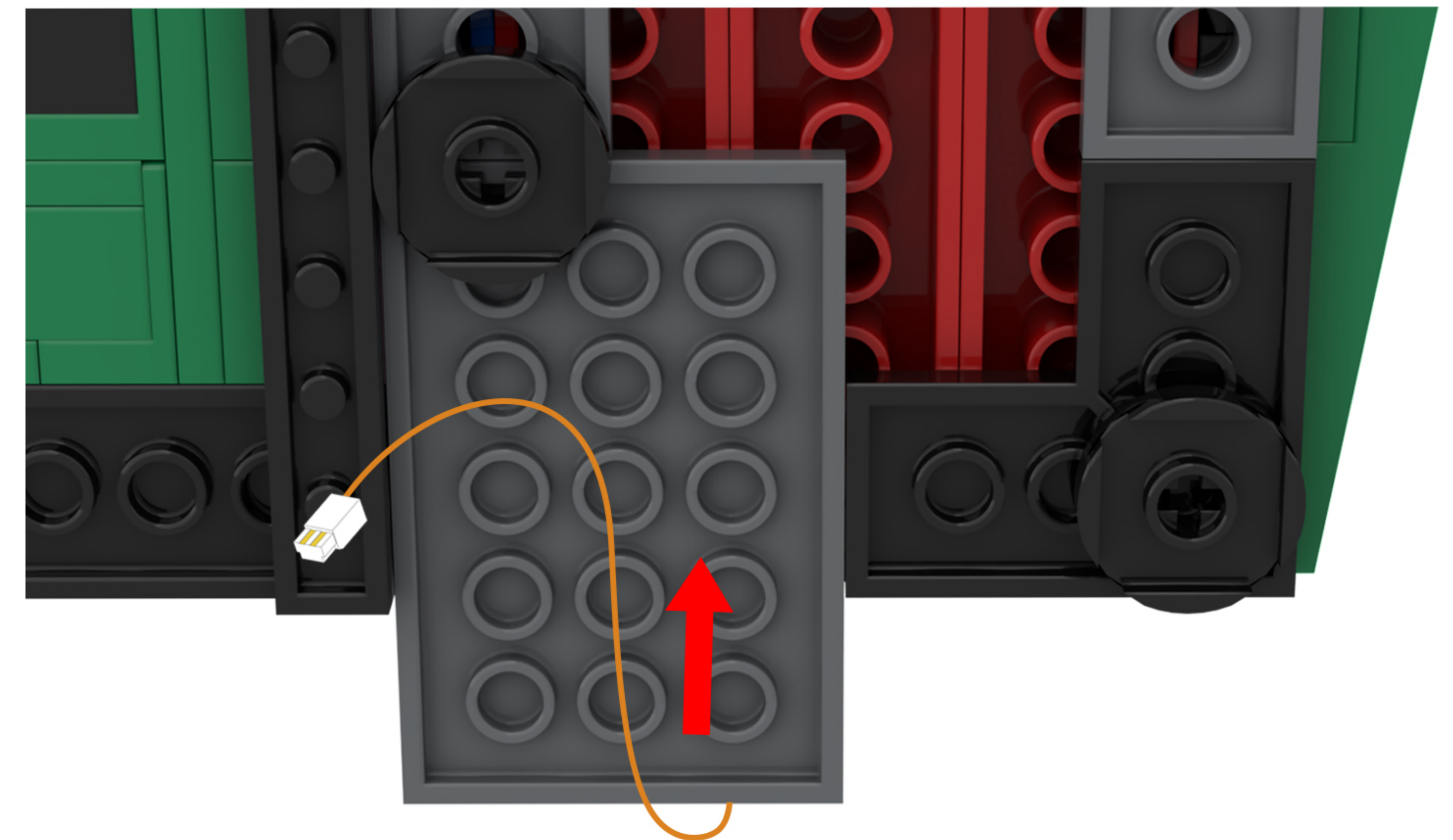

51

EN: Take out the disassembled building blocks, reassemble them, and secure the light cord.

DE: Nehmen Sie die zerlegten Bausteine heraus, setzen Sie sie wieder zusammen und befestigen Sie das Lichtkabel.

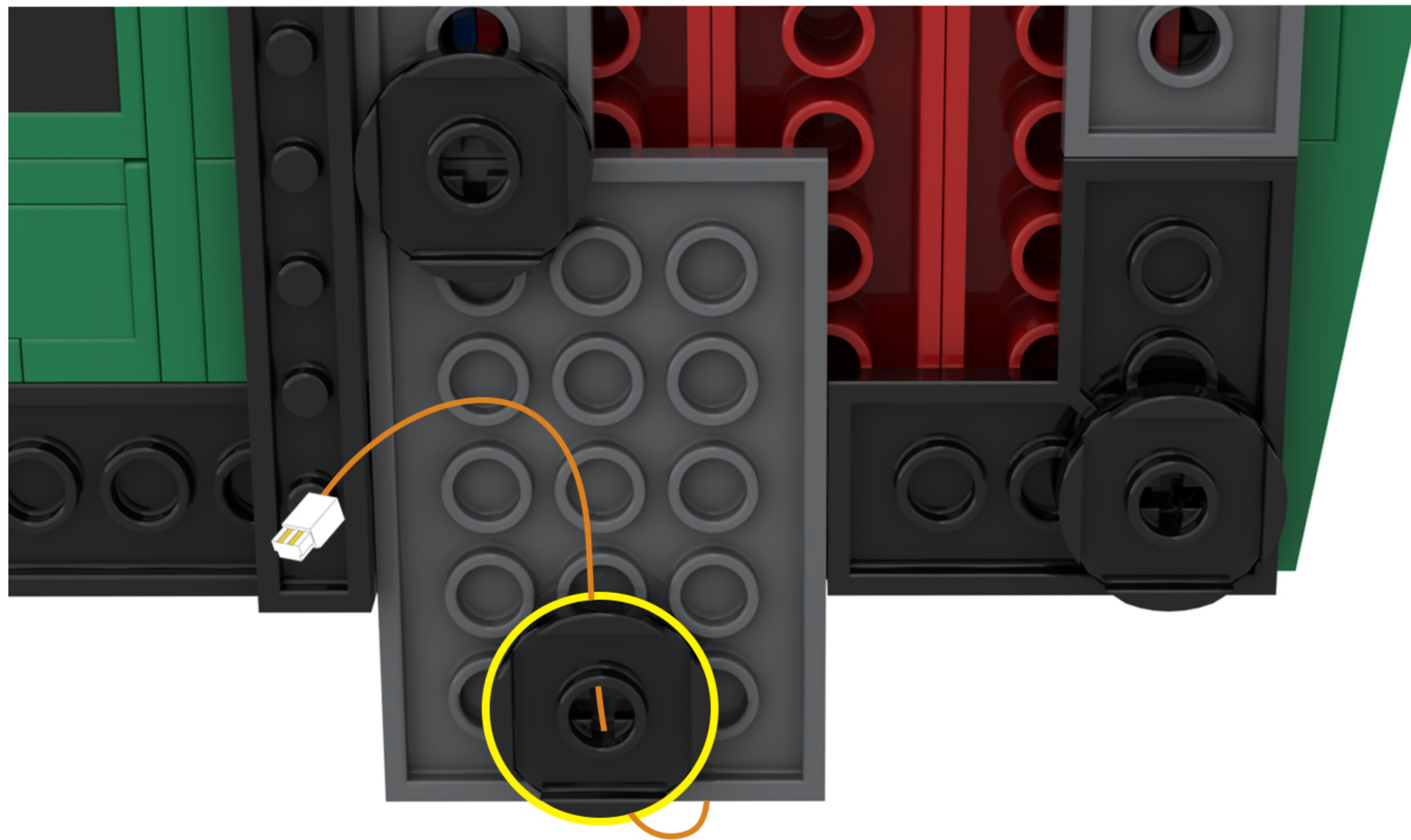
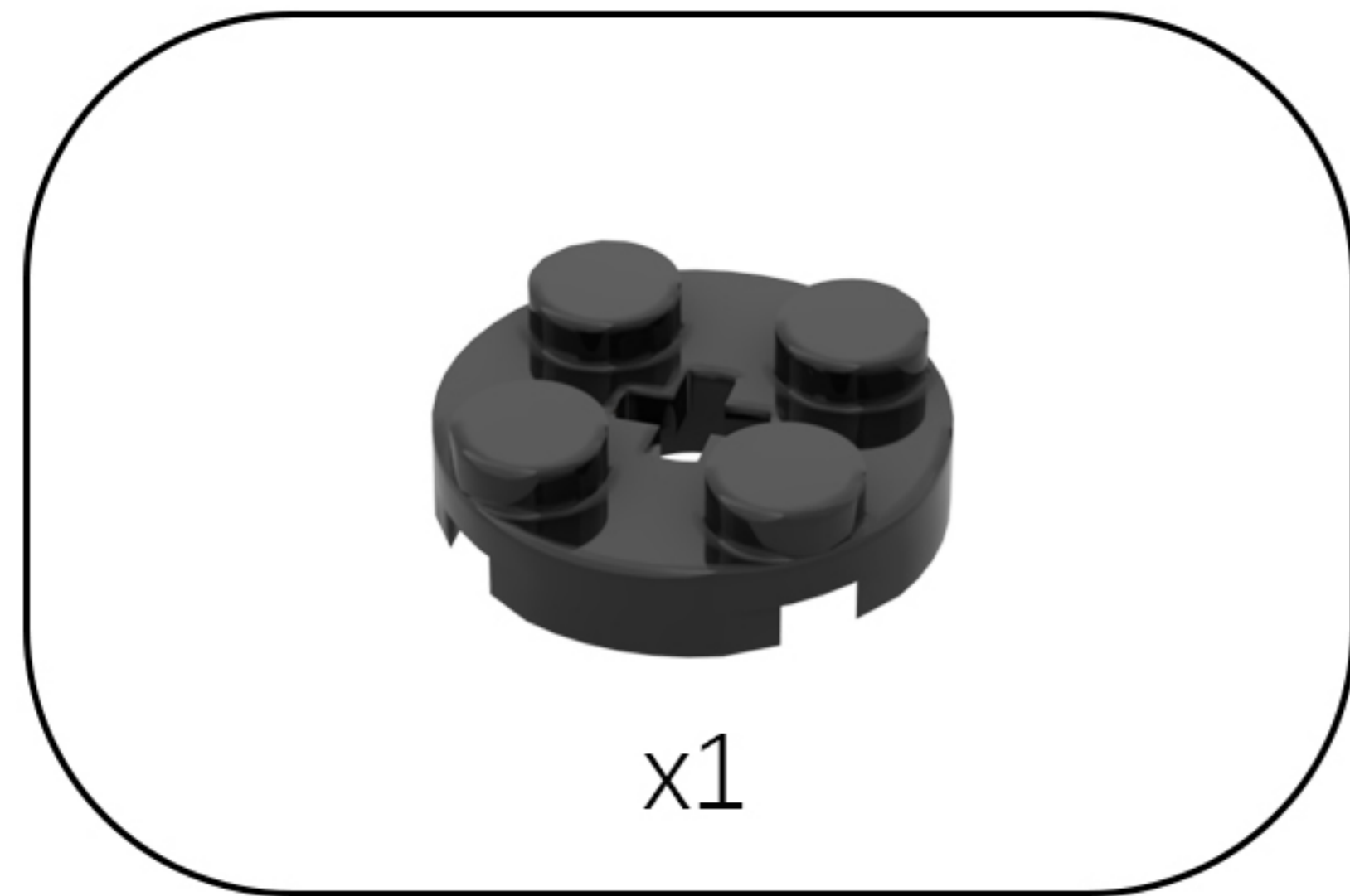

52

EN: Take the expansion board and touch-sensitive dimming module out of Bag 7 and connect them together.

DE: Nehmen Sie die Erweiterungskarte und das berührungsempfindliche Dimmmodul aus Beutel 7 und verbinden Sie beide miteinander.

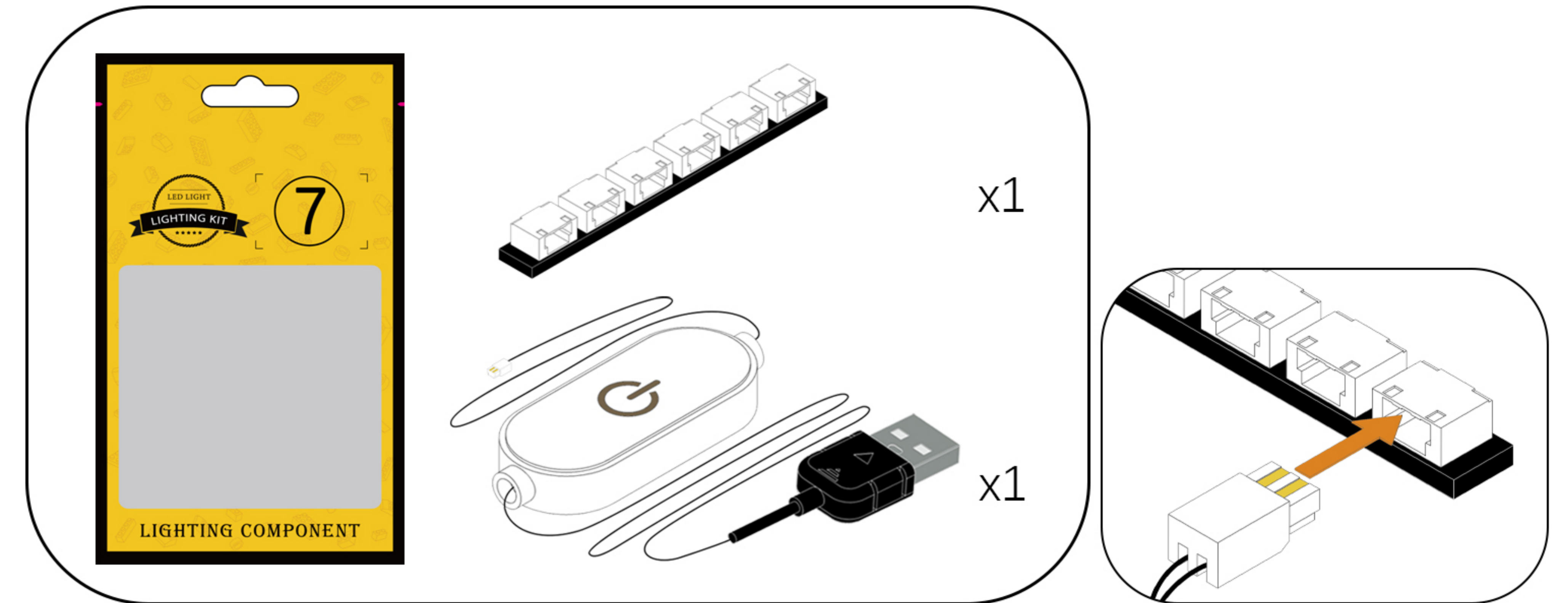

### Touch Dimmer Module - 200CM Introduce

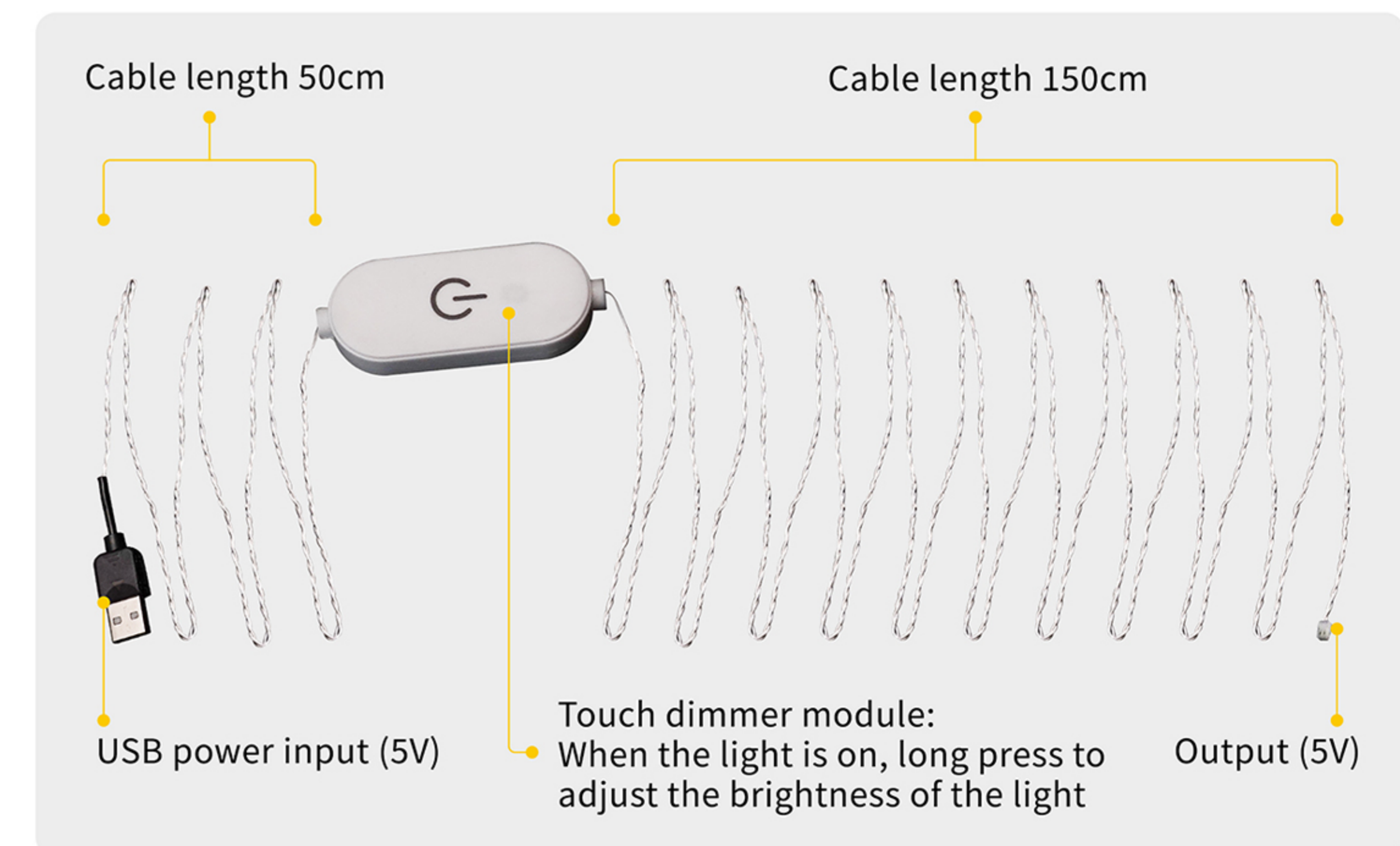

53

EN: Connect the wires from the five string lights to the expansion board in sequence.

DE: Schließen Sie die Kabel der fünf Lichterketten der Reihe nach an die Erweiterungsplatine an.

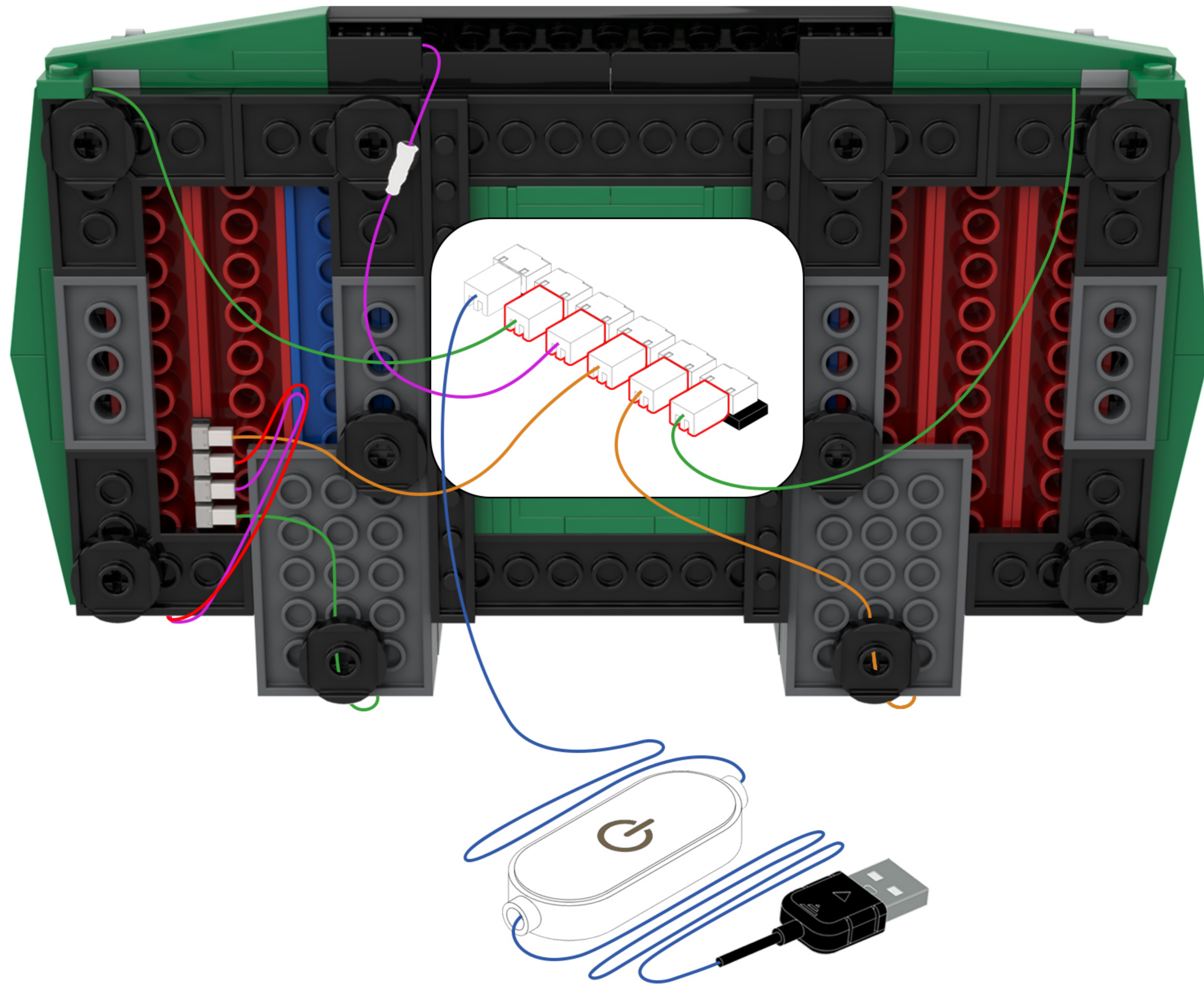
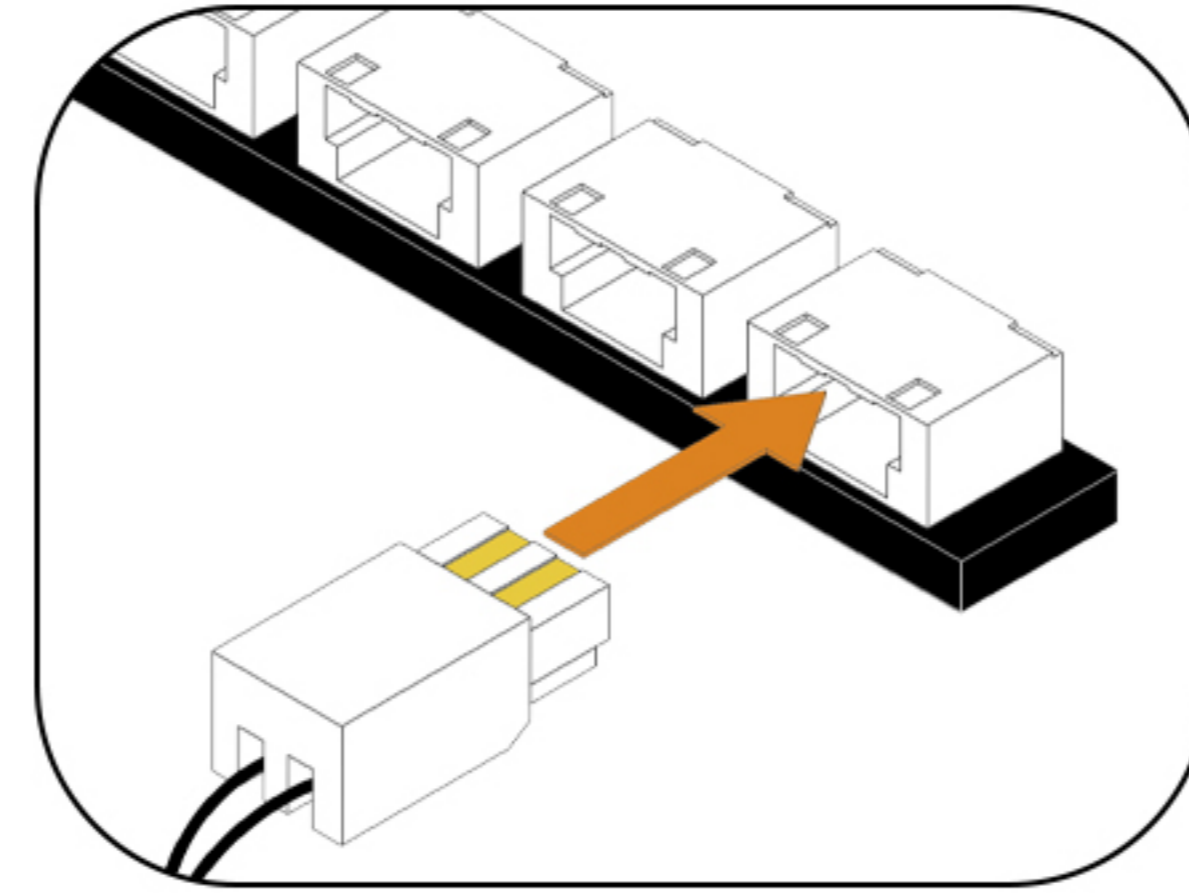

54

EN: Peel off the adhesive backing of the expansion board and attach it to the location shown in the illustration.

DE: Entfernen Sie die Schutzfolie von der Rückseite der Erweiterungsplatte und kleben Sie sie an die in der Abbildung gezeigte Stelle.

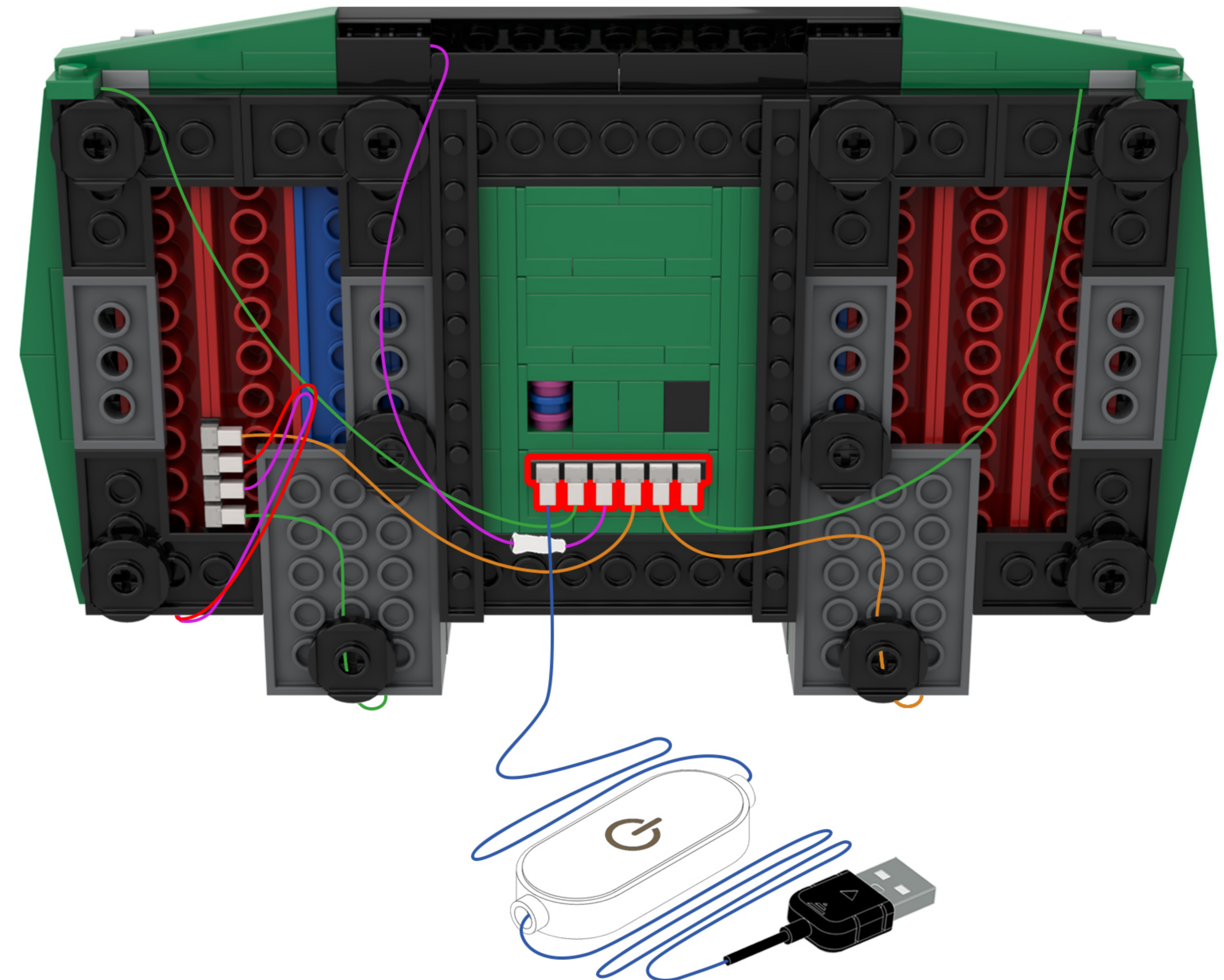

55

EN: Remove the building blocks one by one.  
DE: Entfernen Sie die Bausteine nacheinander.

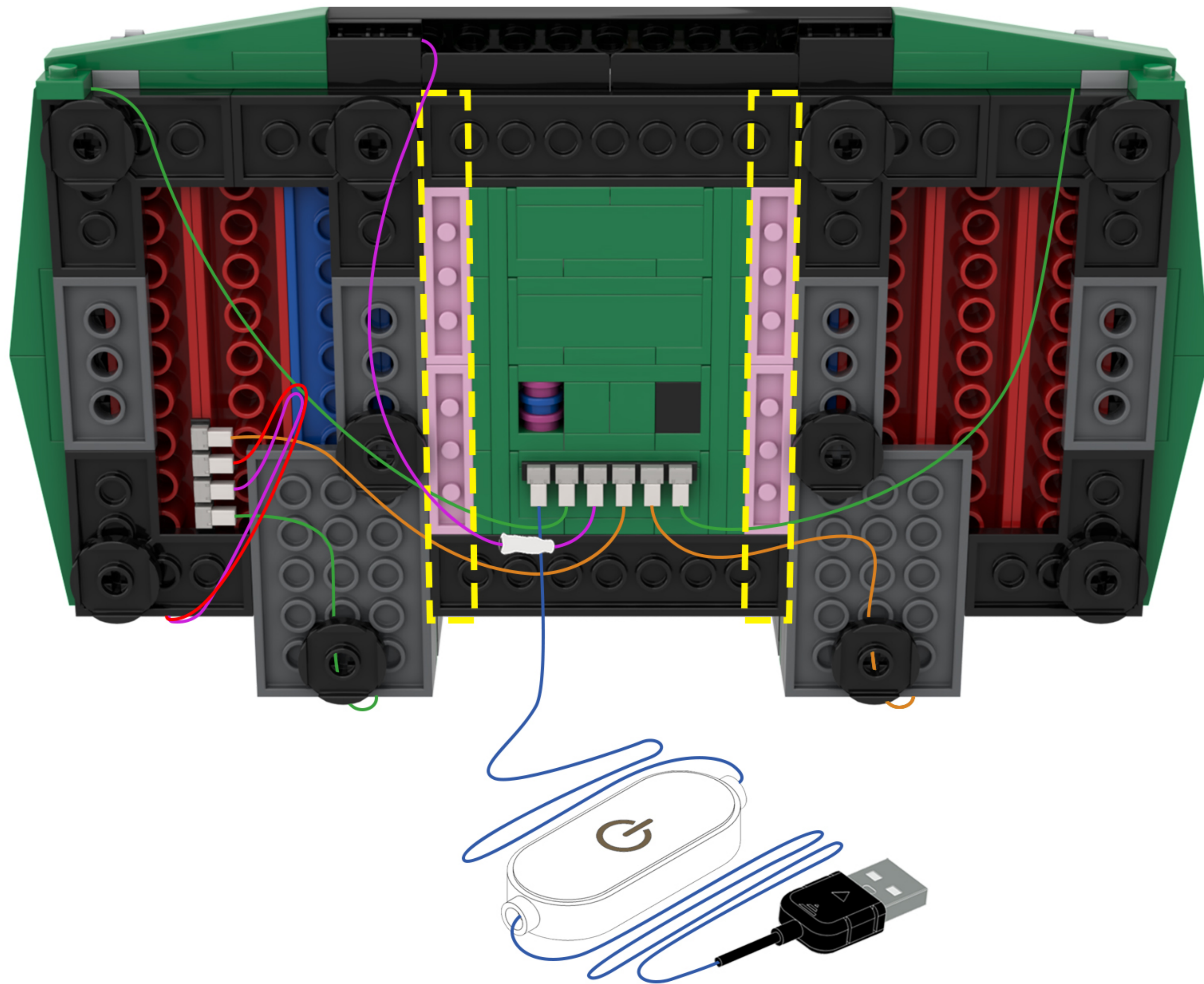
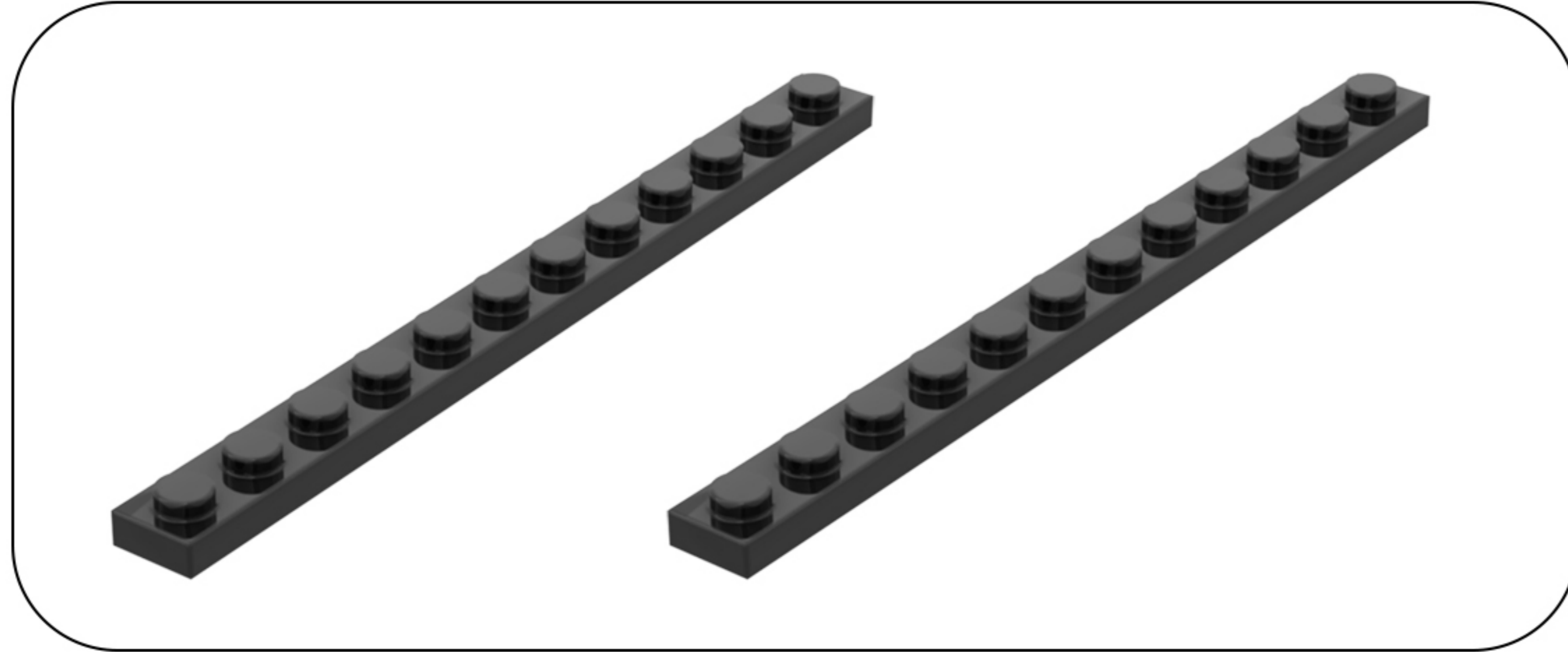

56

EN: Arrange the wires for the three string lights on the left as shown in the figure.  
DE: Ordnen Sie die Kabel der drei Lichterketten auf der linken Seite wie in der Abbildung gezeigt an.

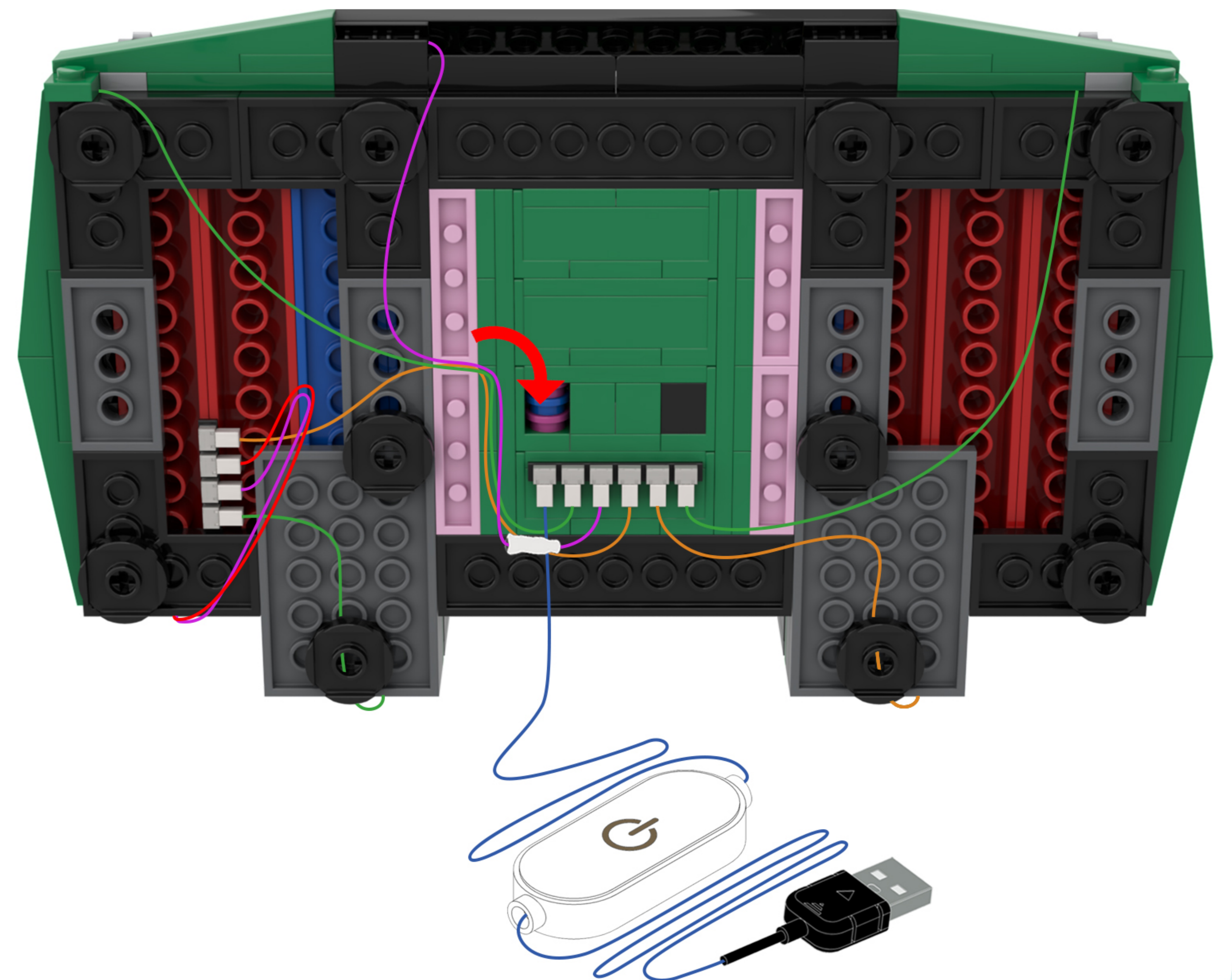
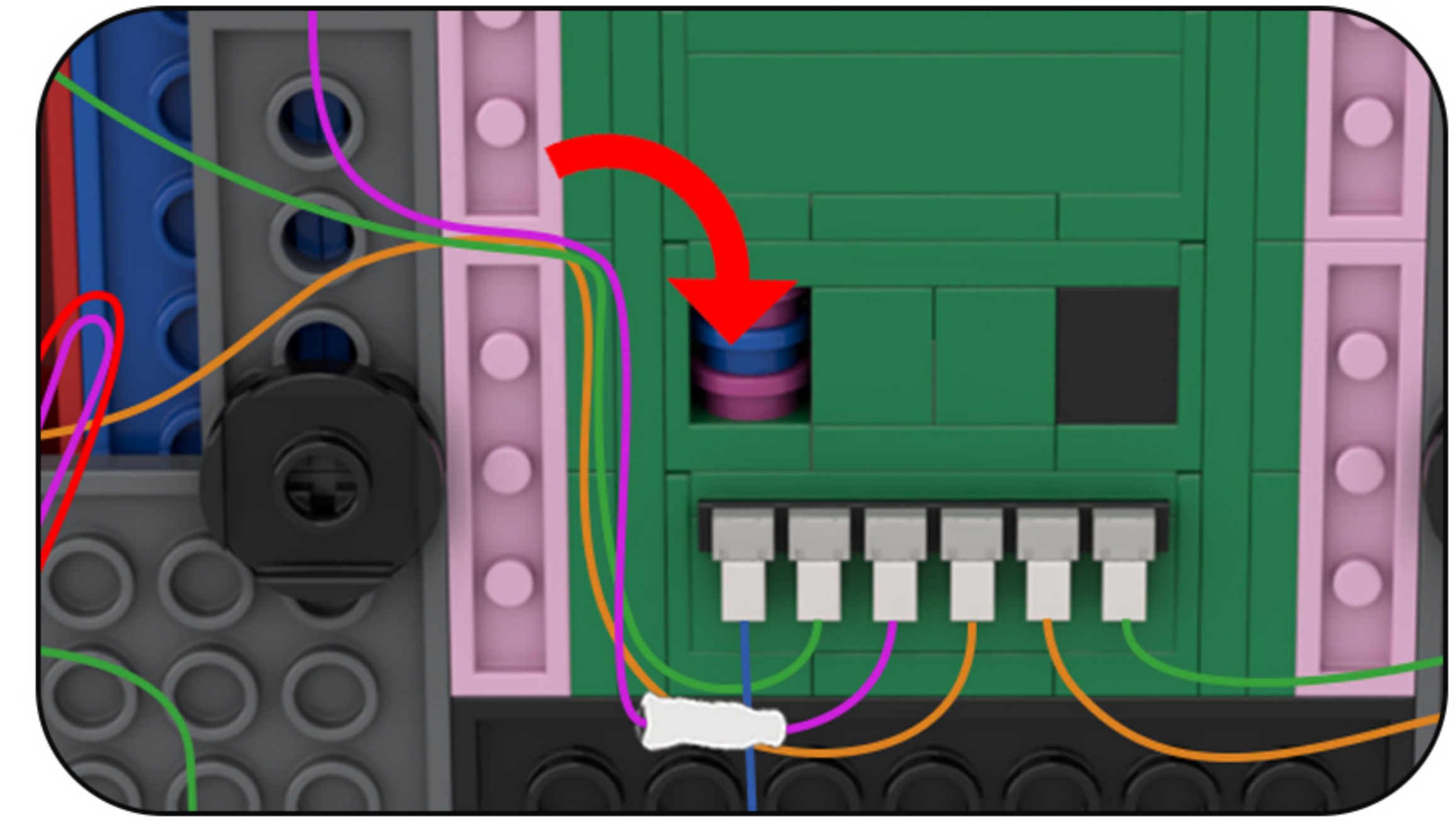

57

EN: Take out the disassembled building blocks, reassemble them, and secure the light cord.

DE: Nehmen Sie die zerlegten Bausteine heraus, setzen Sie sie wieder zusammen und befestigen Sie das Lichtkabel.

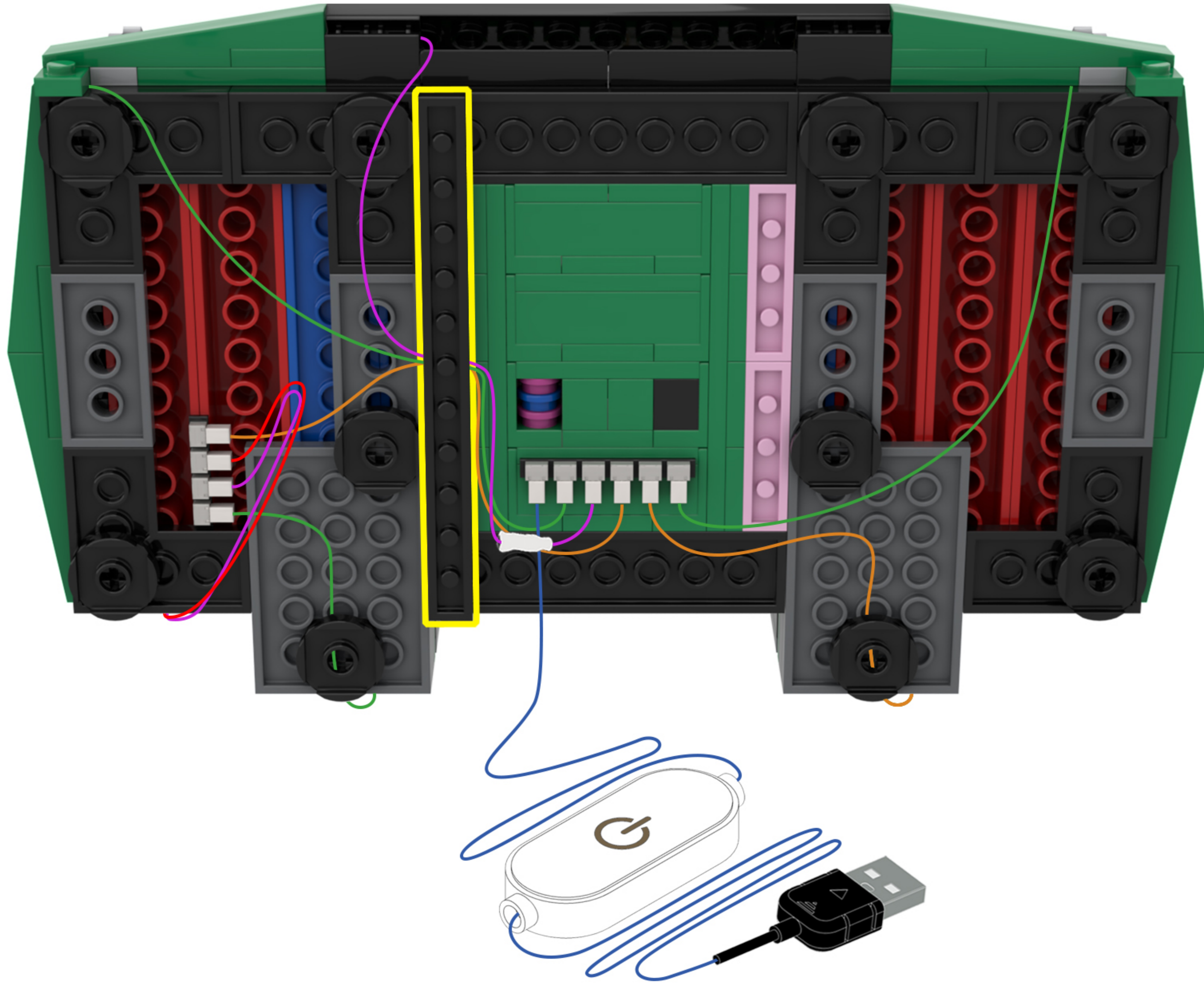
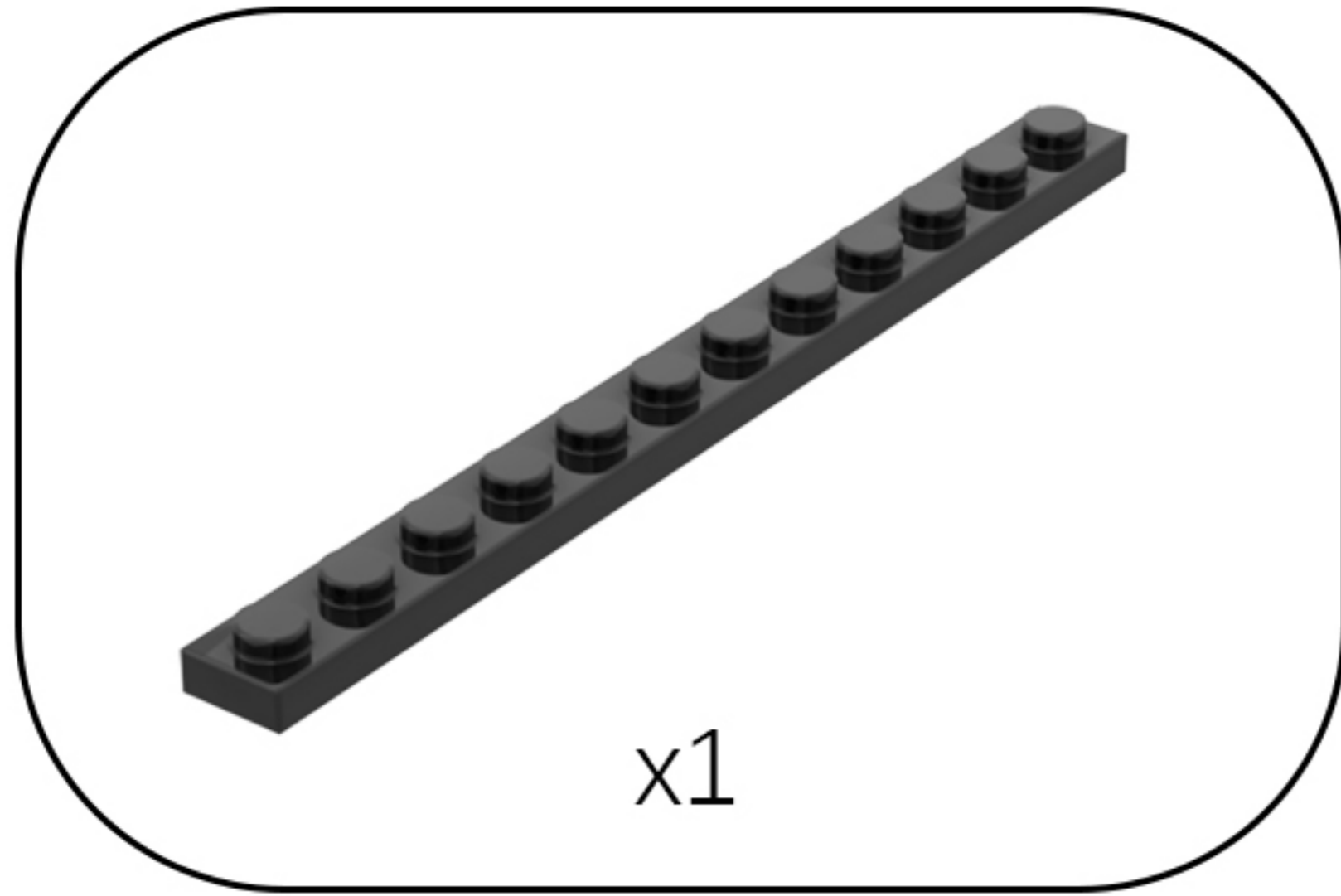

58

EN: Arrange the two right-hand light cables as shown in the illustration.

DE: Ordnen Sie die beiden rechten Lichtkabel wie in der Abbildung gezeigt an.

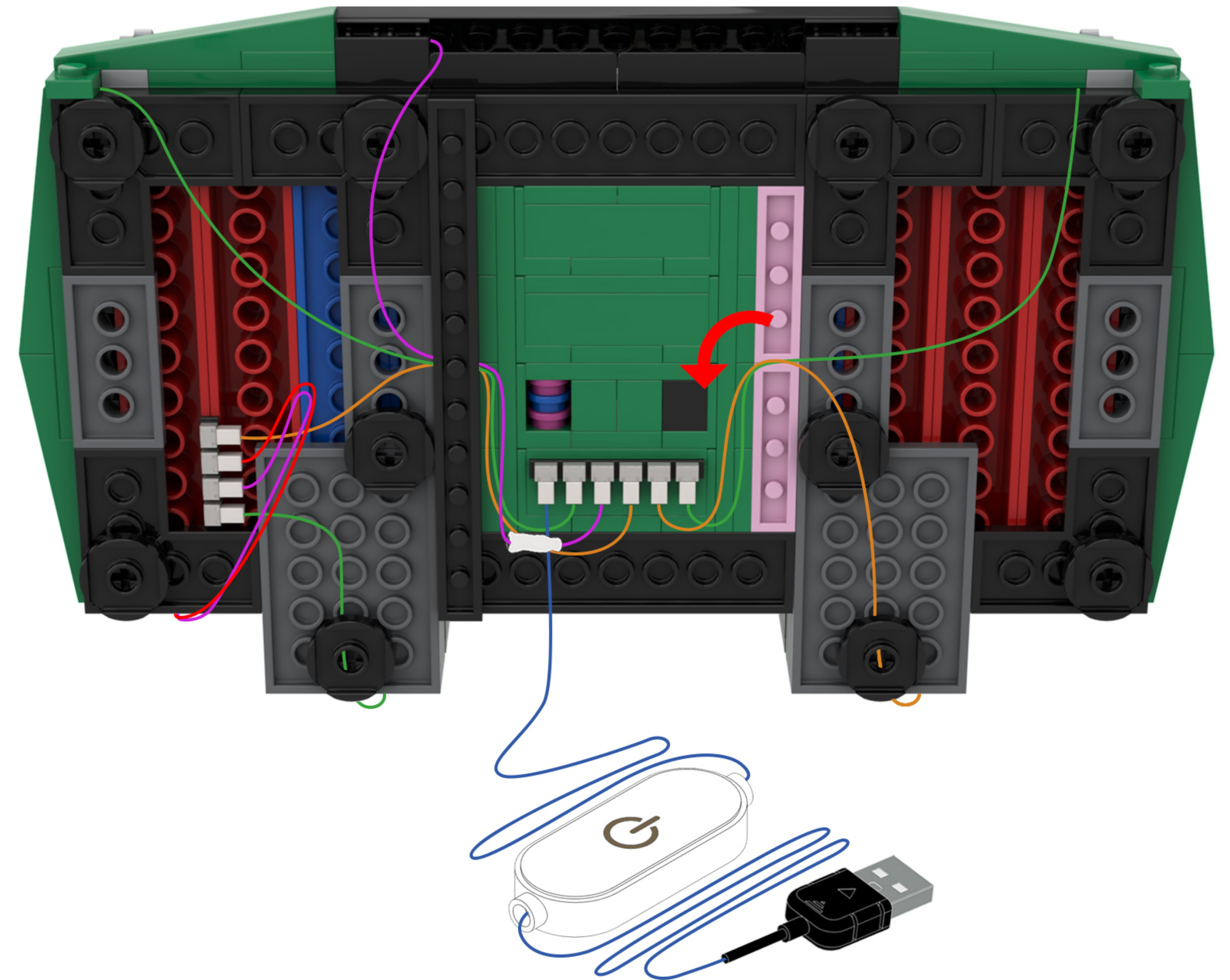
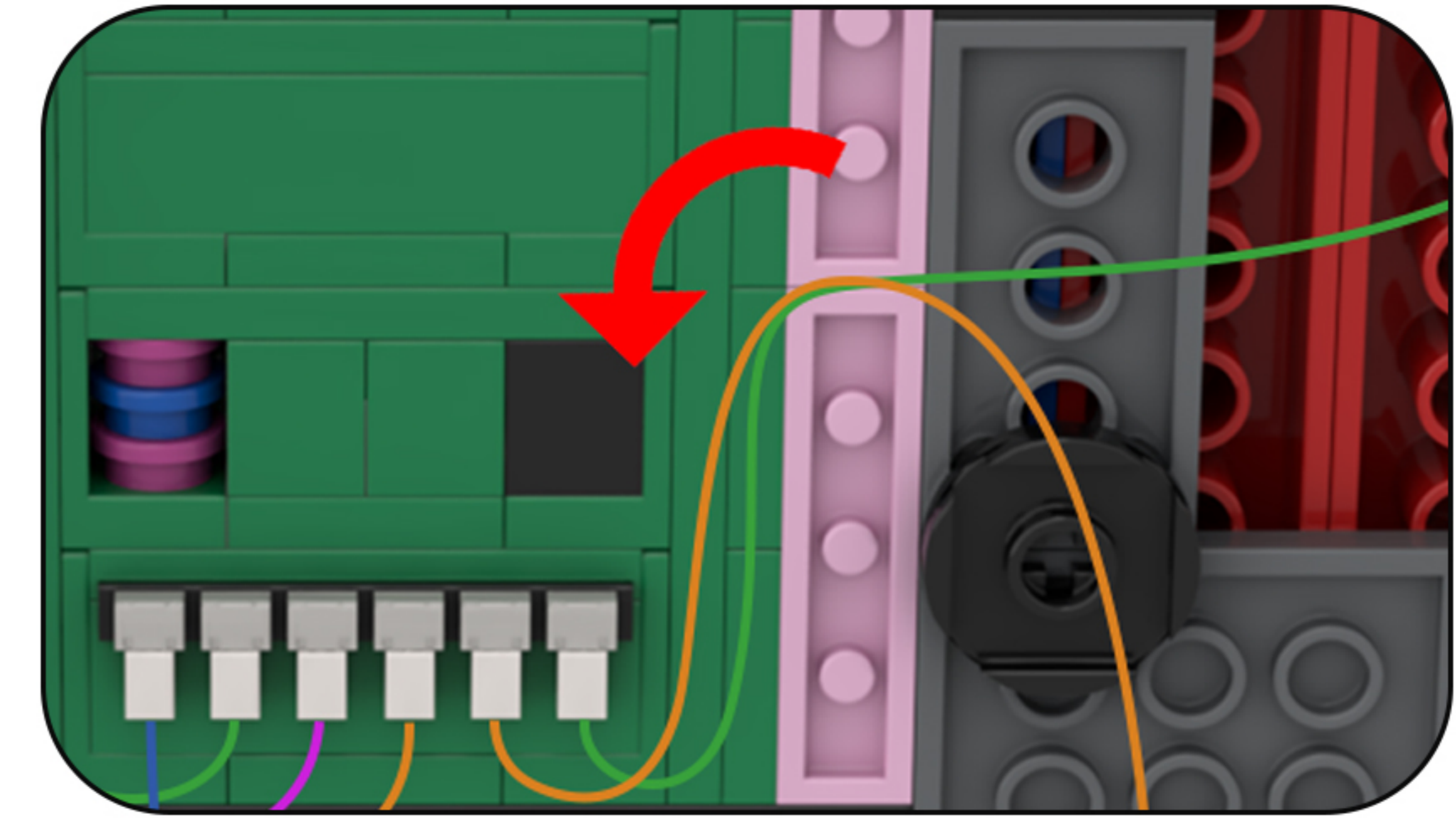

59

EN: Take out the disassembled building blocks, reassemble them, and secure the light cord.

DE: Nehmen Sie die zerlegten Bausteine heraus, setzen Sie sie wieder zusammen und befestigen Sie das Lichtkabel.

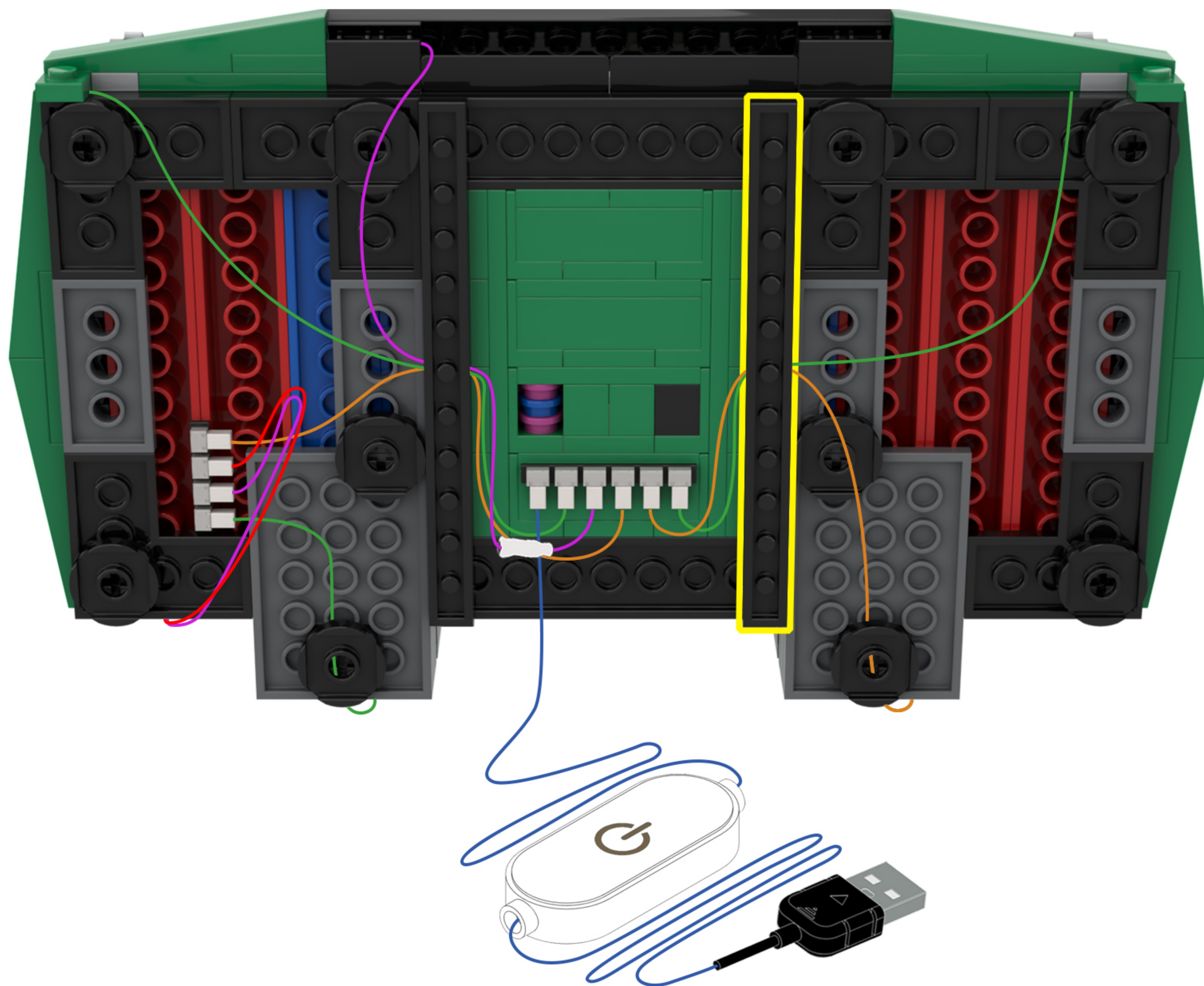
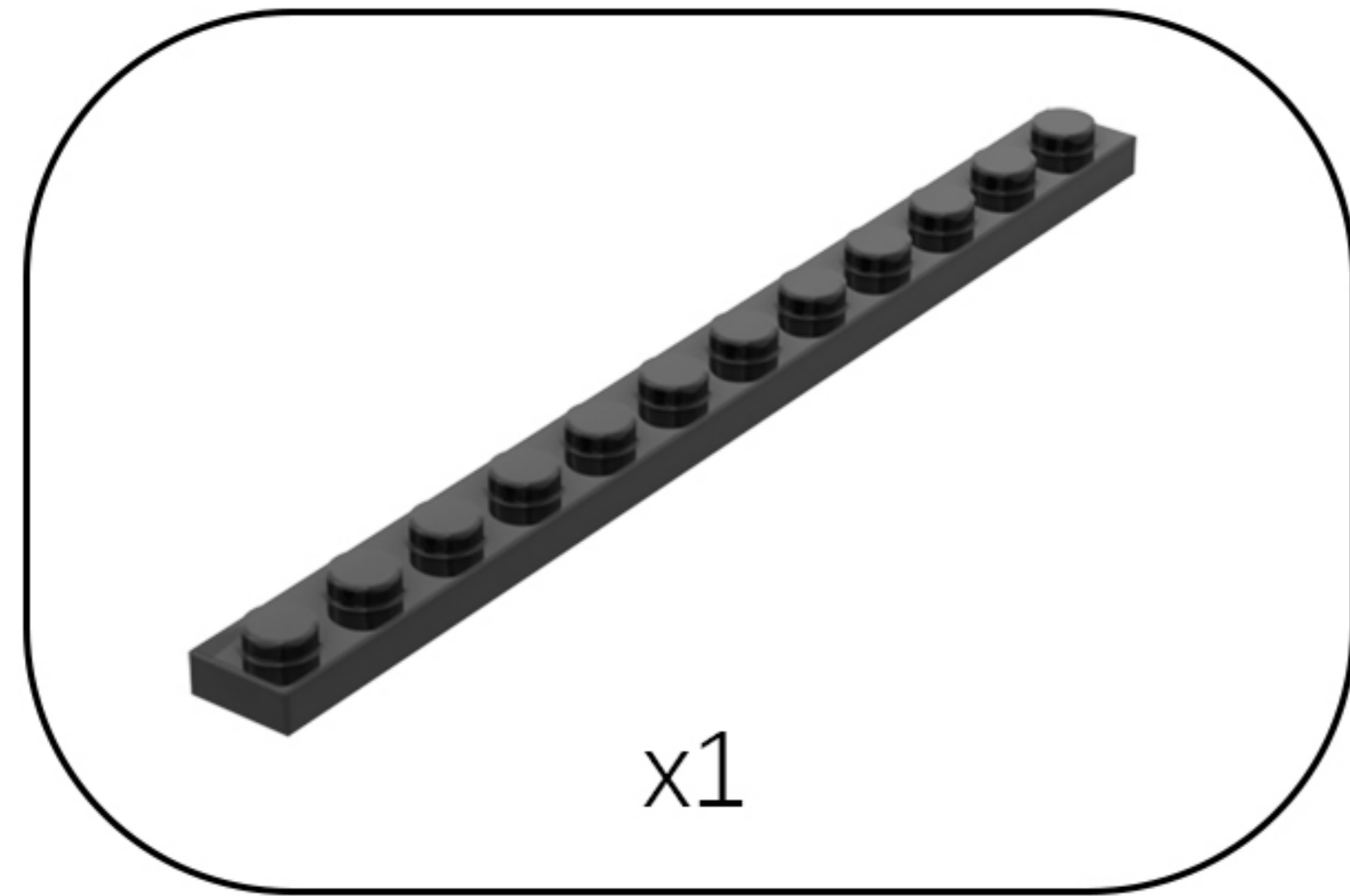

60

EN: Flip the model to restore it to its original state.

DE: Drehen Sie das Modell um, um es in seinen ursprünglichen Zustand zurückzusetzen.

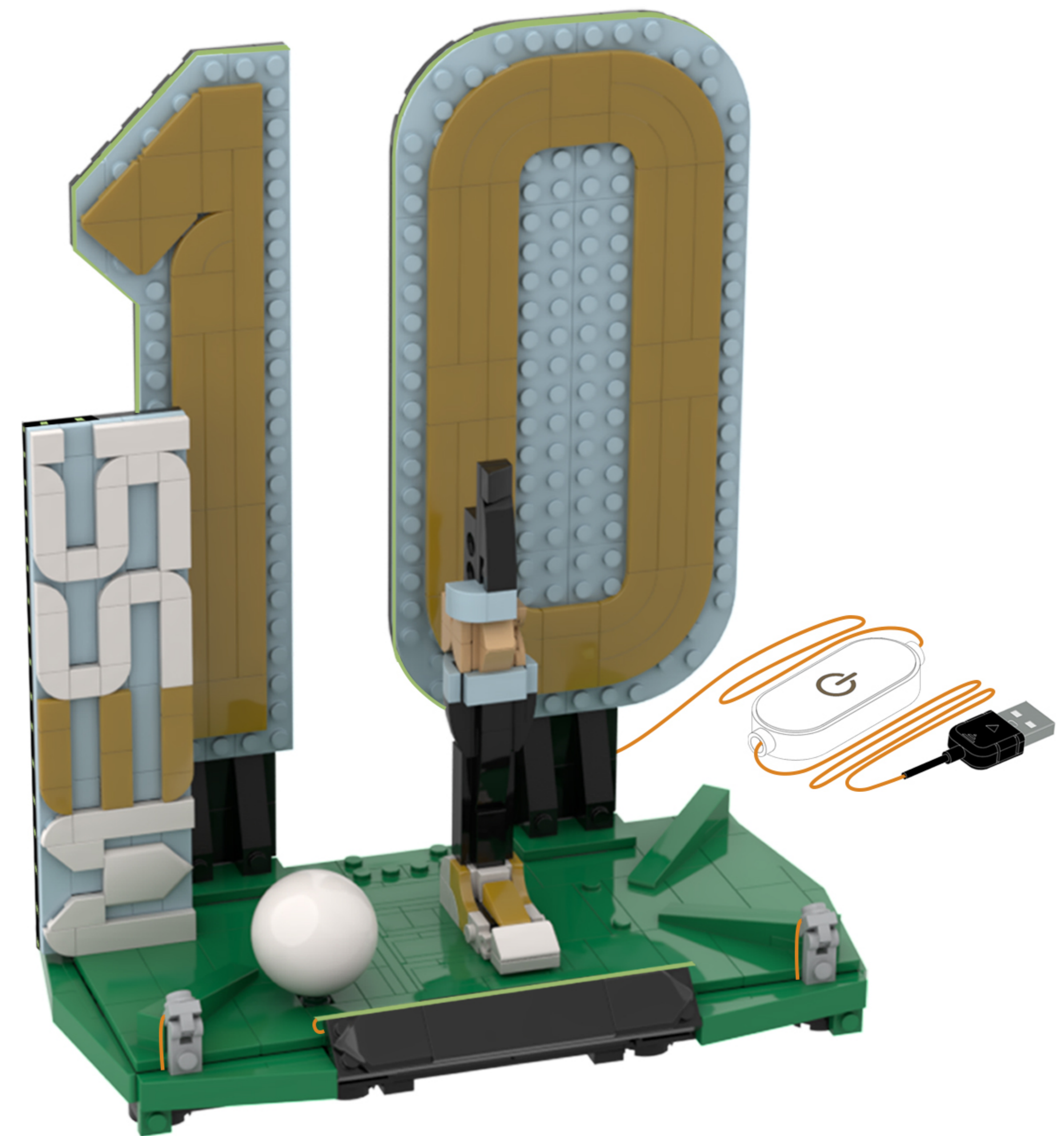

61

EN: Take out the disassembled building blocks and reassemble them.

DE: Nehmen Sie die zerlegten Bausteine heraus und setzen Sie sie wieder zusammen.



62

EN: Once installed, connect the power supply and give it a try!

DE: Die Installation ist abgeschlossen. Schließen Sie das Gerät an die Stromversorgung an und probieren Sie es aus!





Above our designers to provide the relevant ideas and instructions. But please move to the following:

- 1: about our company this product parts material, product quality do you have comments and suggestions?
- 2: about this product installation instructions and installation of the degree of difficulty do you have views and suggestions?
- 3: if in the operation of the product we provide ideas encountered any problems, please contact us in a timely manner.

## Tips

If you encounter any installation problems please contact the seller, we will be happy to help you solve!