

INSTALLATION GUIDE

Vini Jr. – Football Highlights 43027



LED light kit compatible with Lego

Instructions for installing this kit:

This set includes 6 pouches. (The battery case functions similarly, please select your own power source. This article uses a USB power cable.)

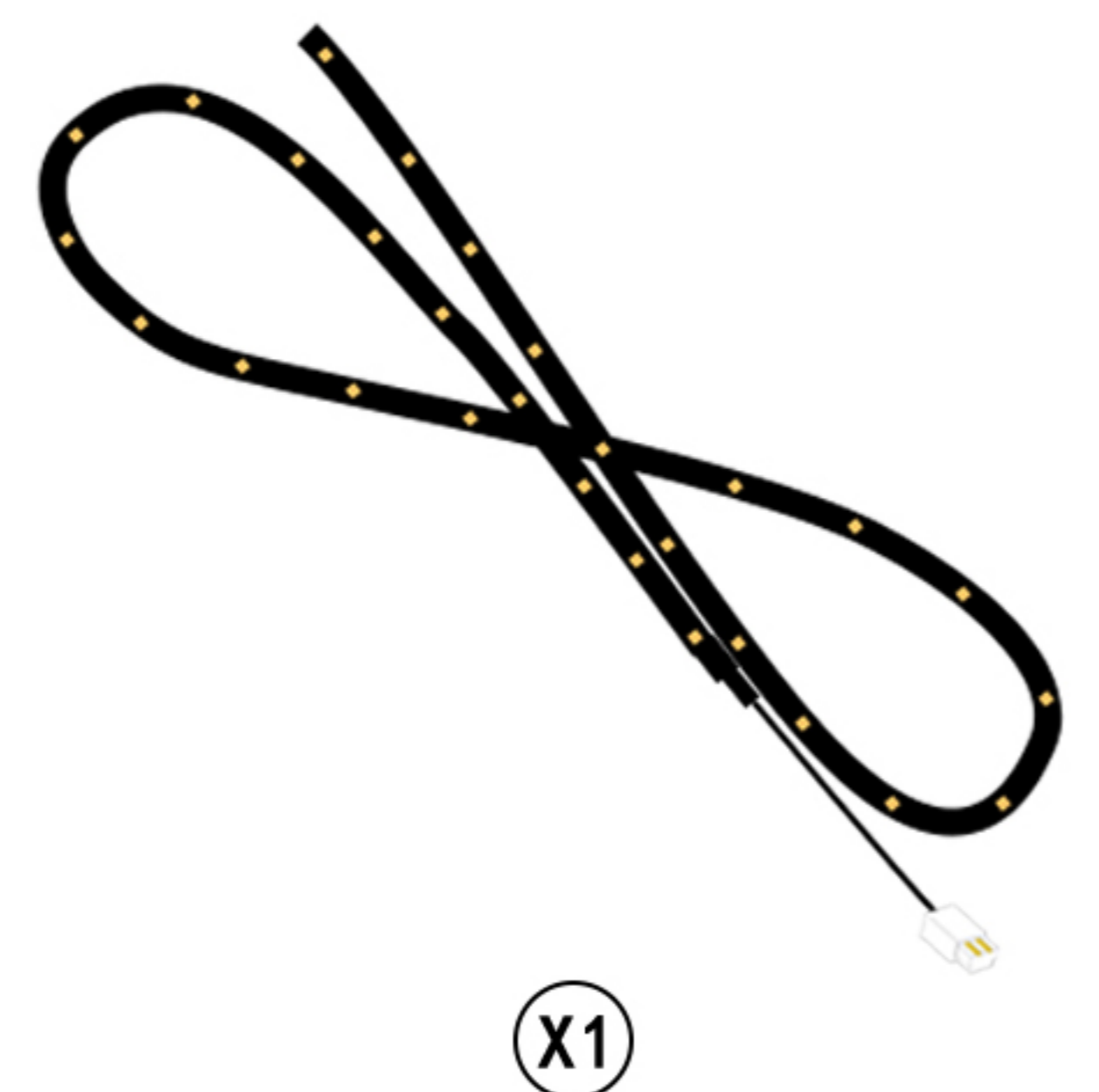
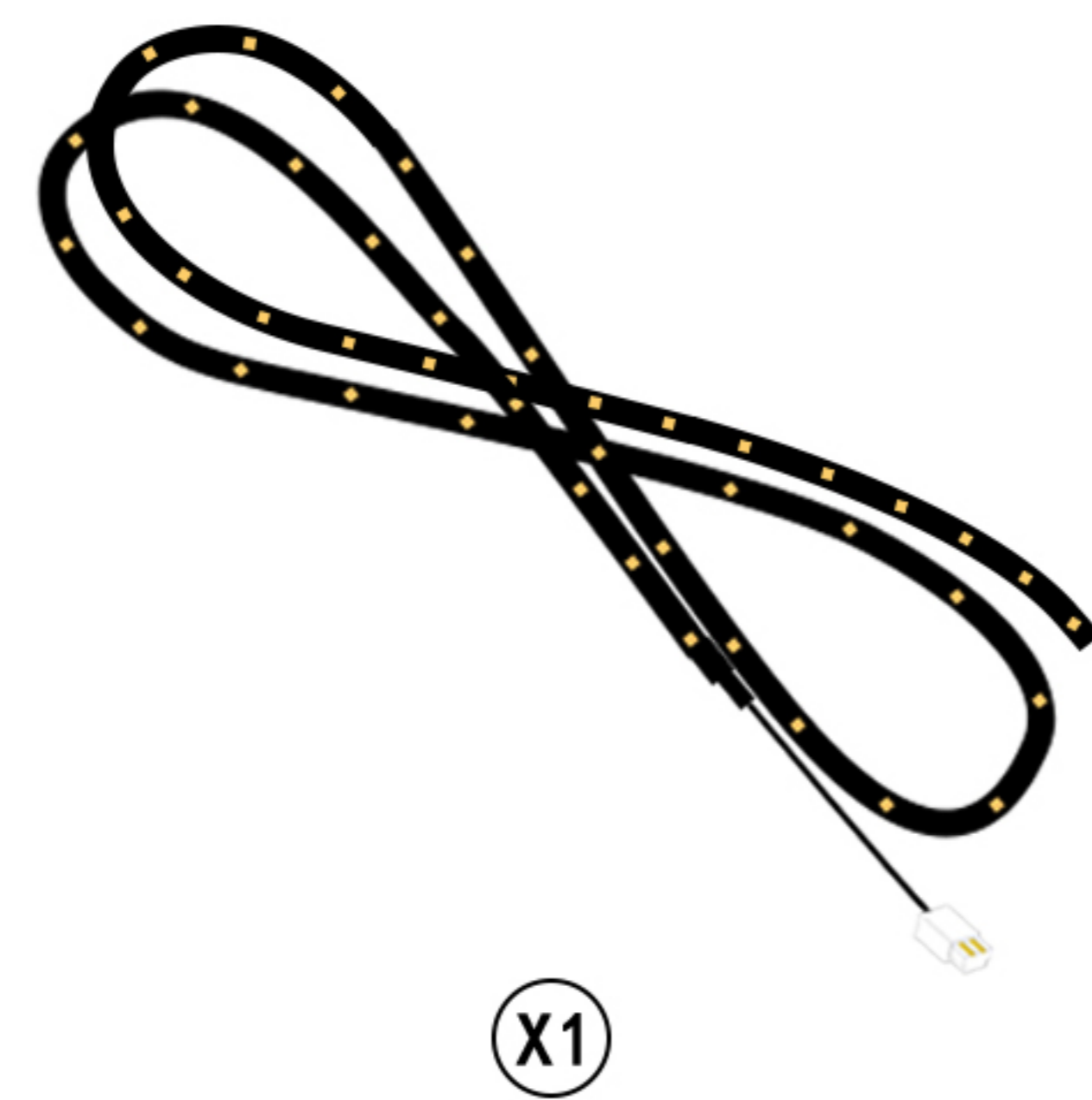
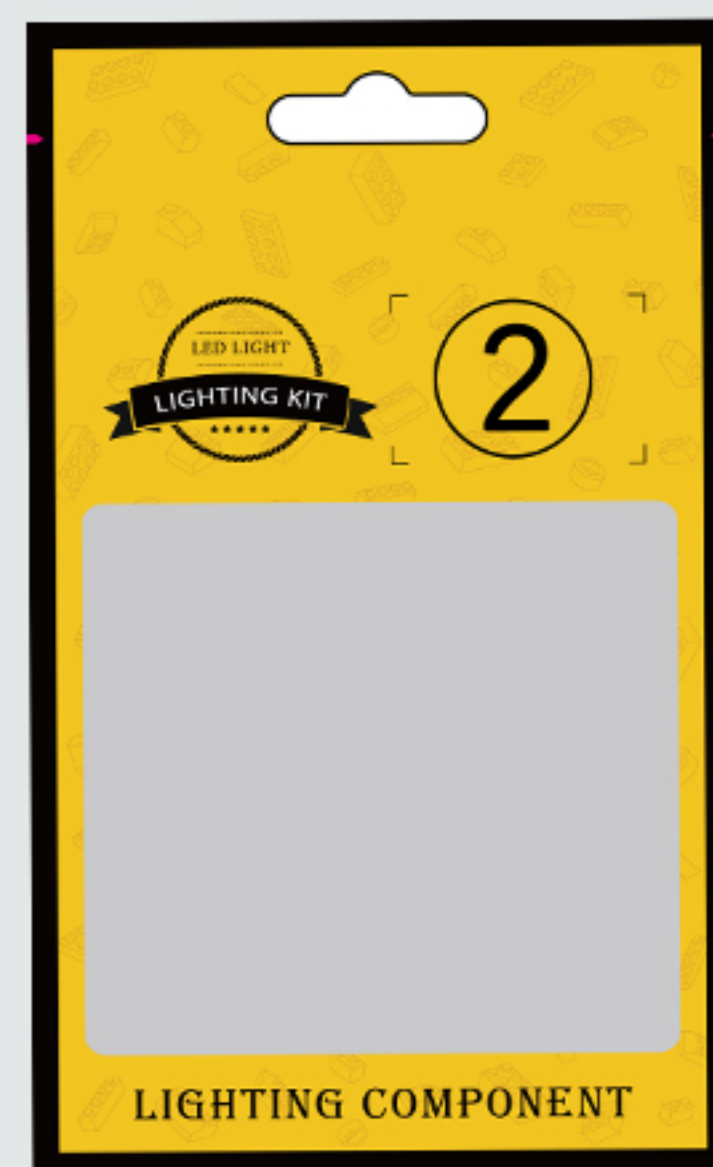
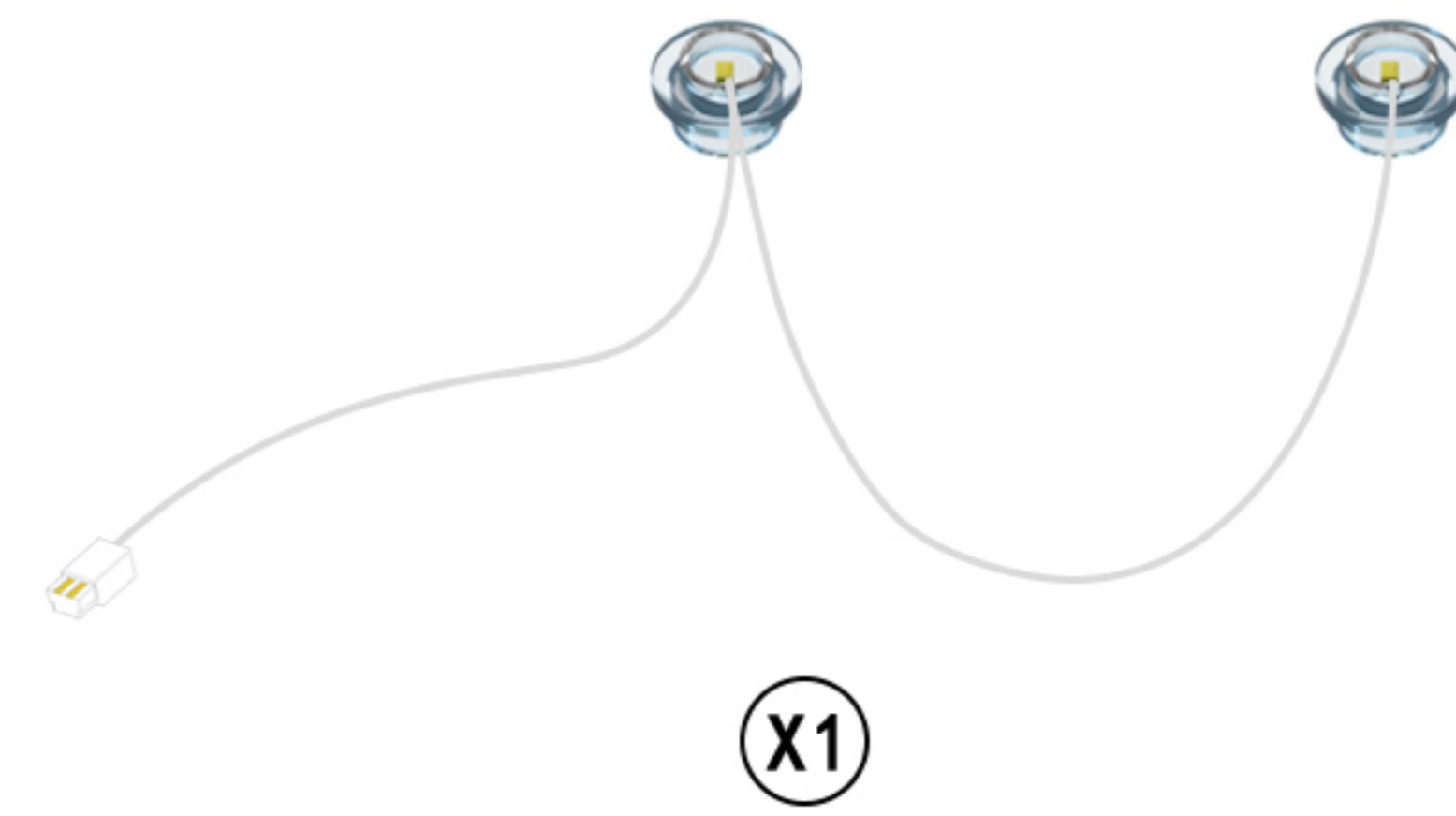
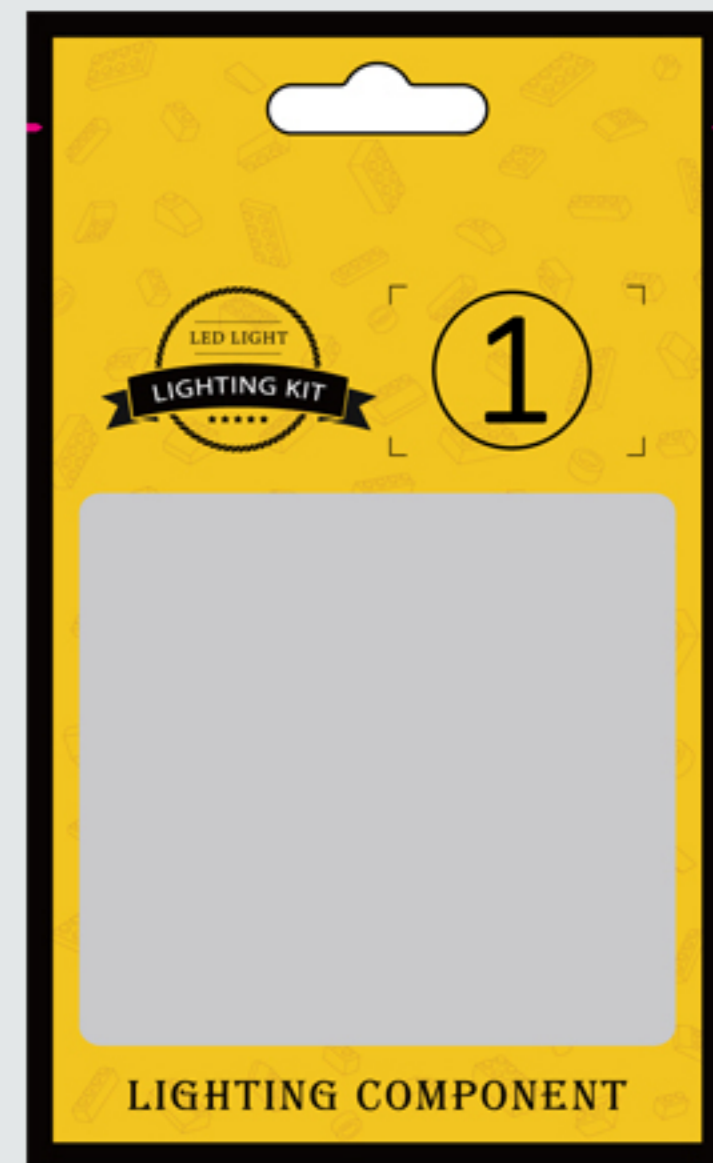

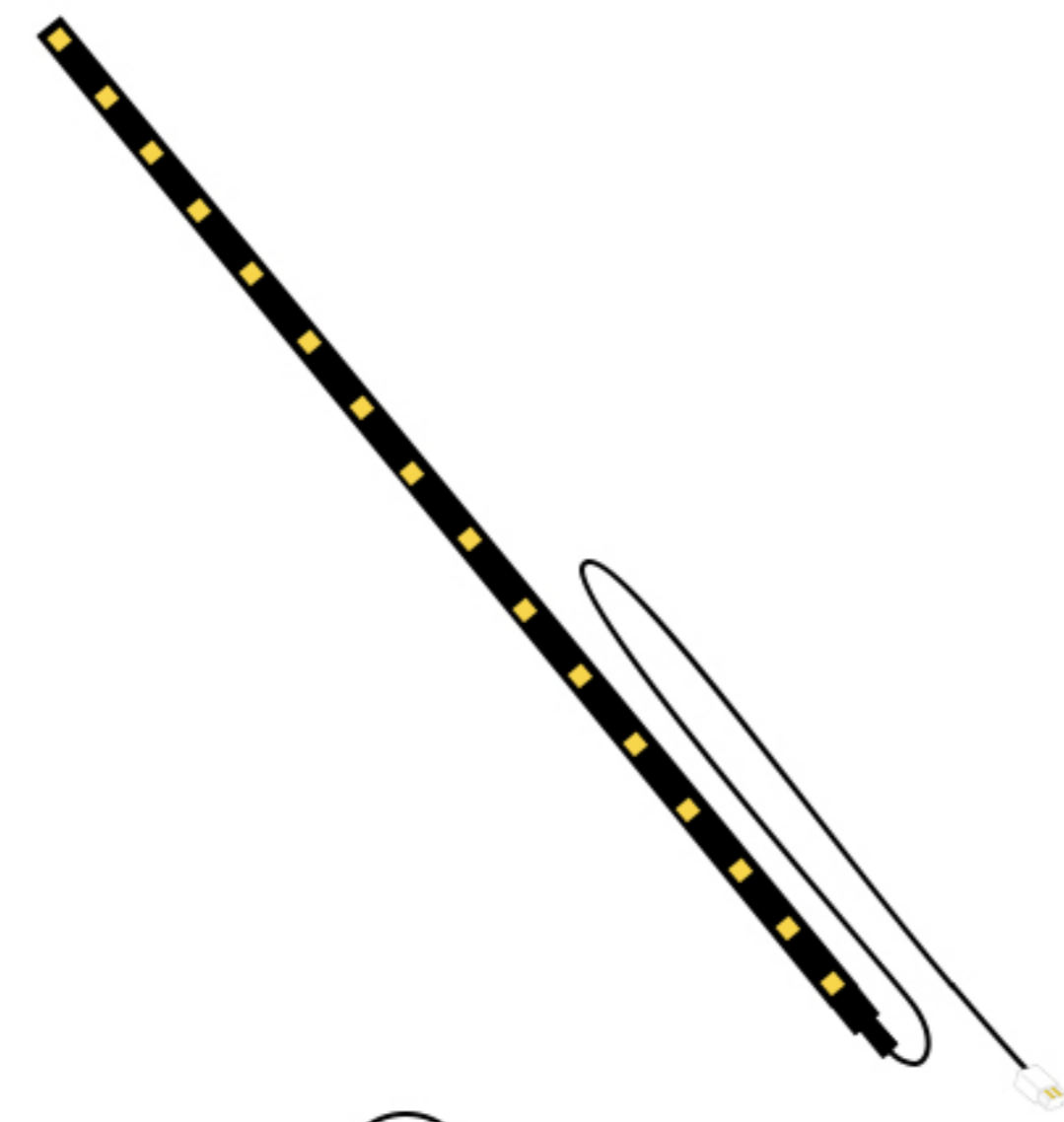

(X2)

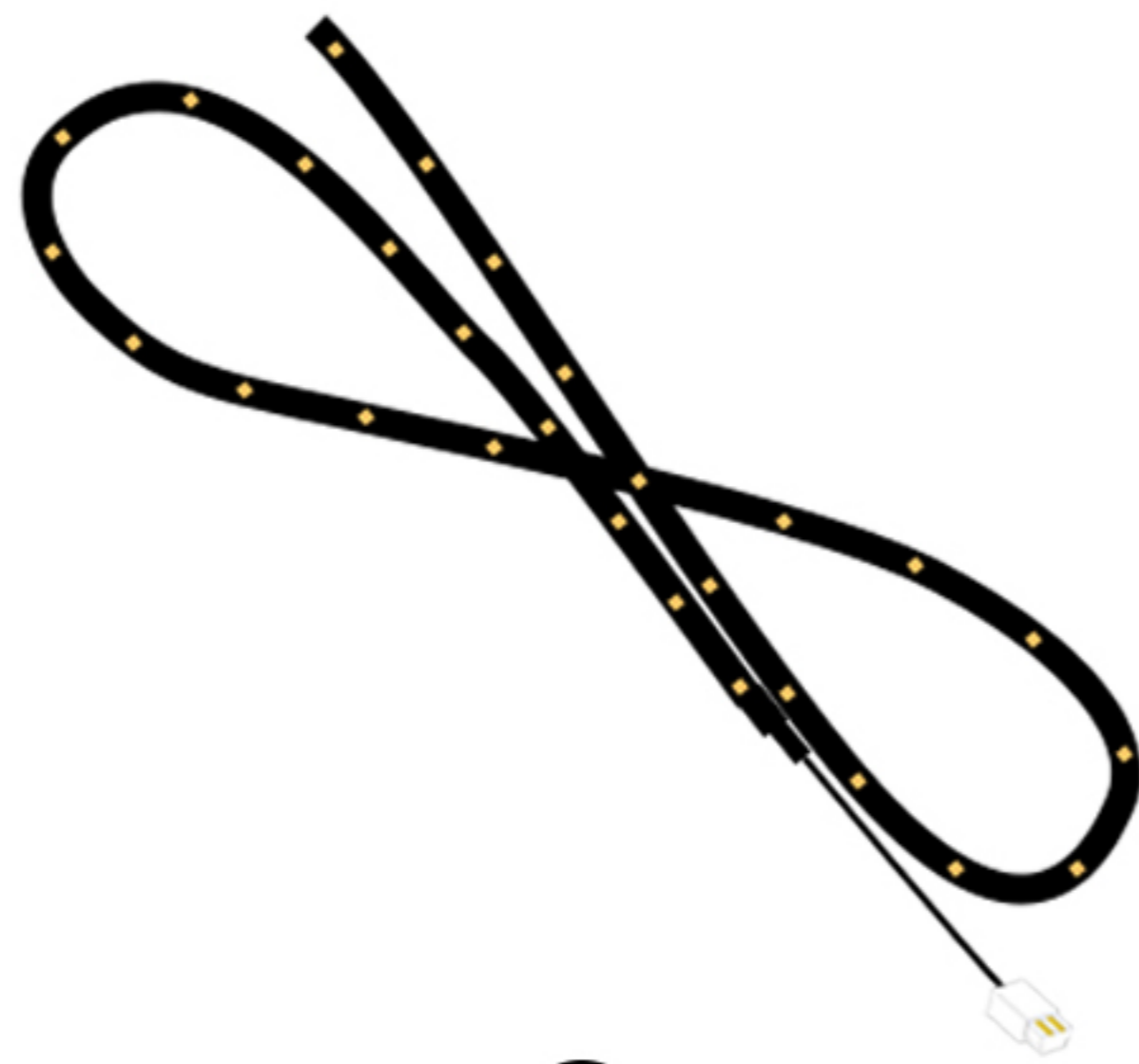

(X1)

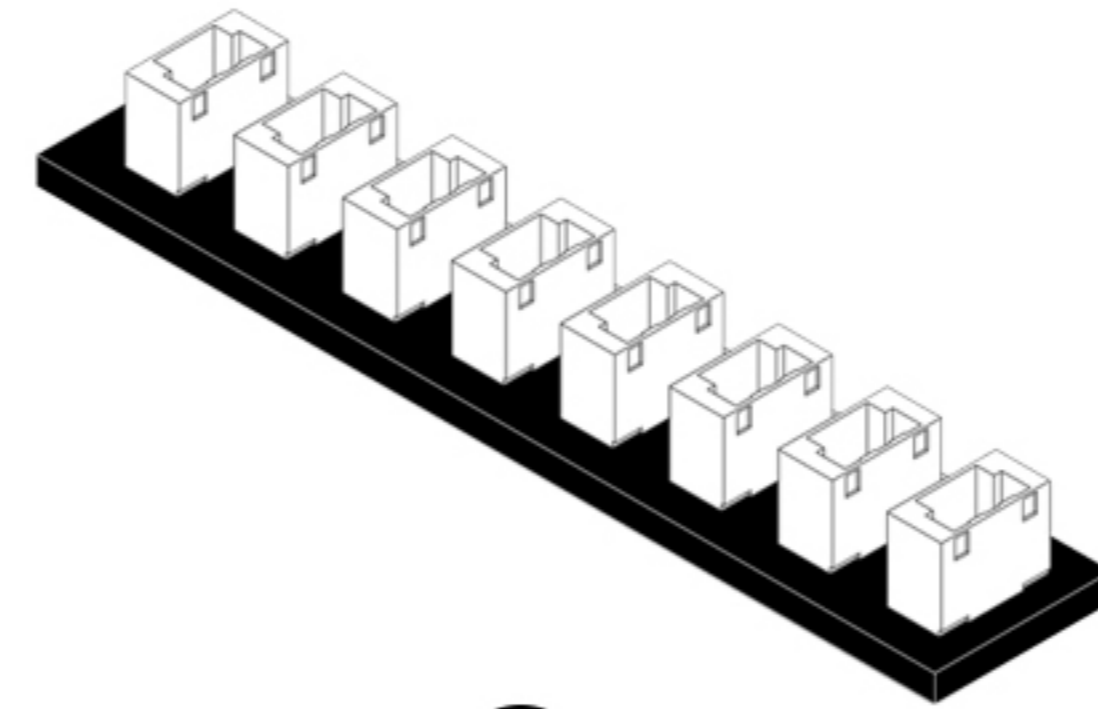

(X1)

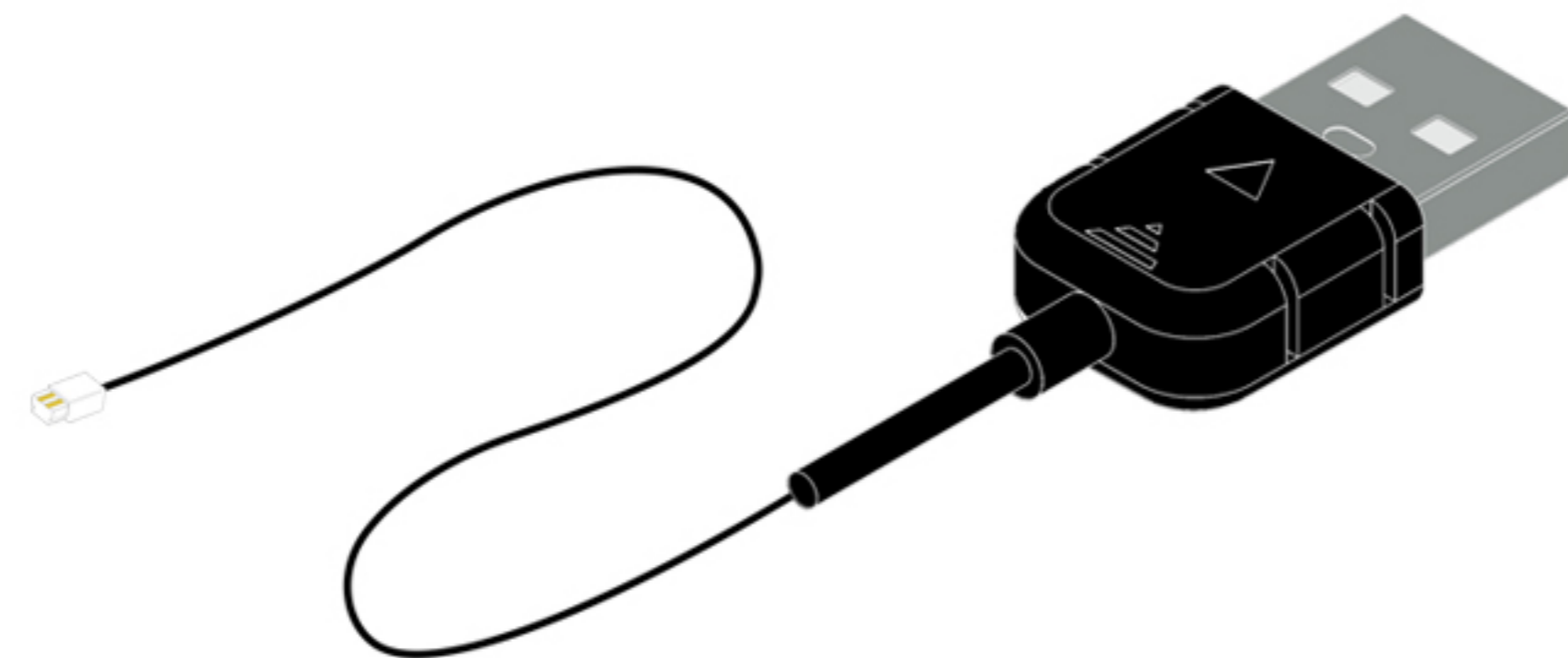
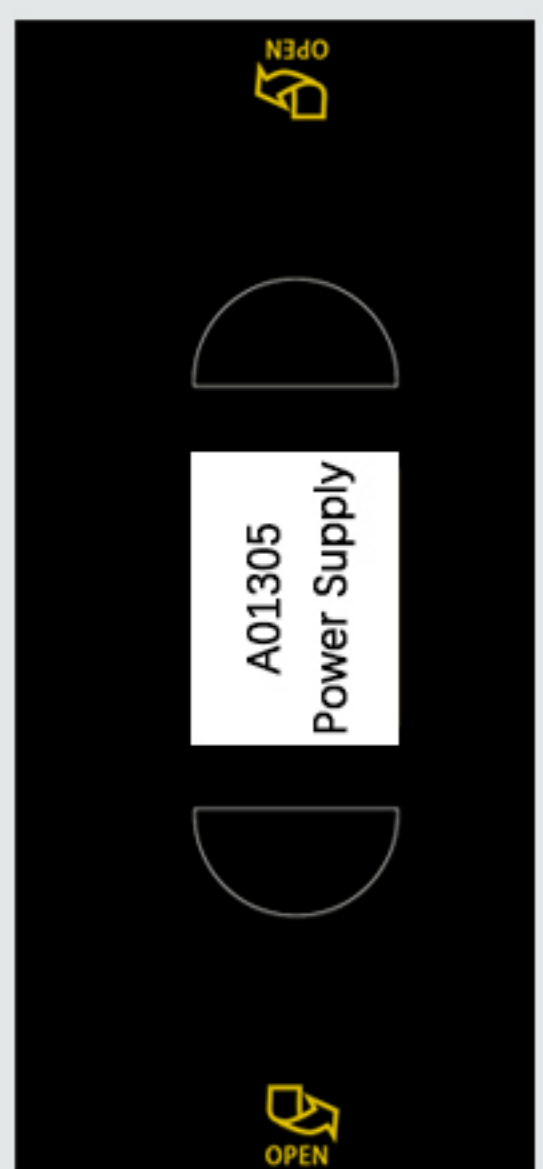

(X1)

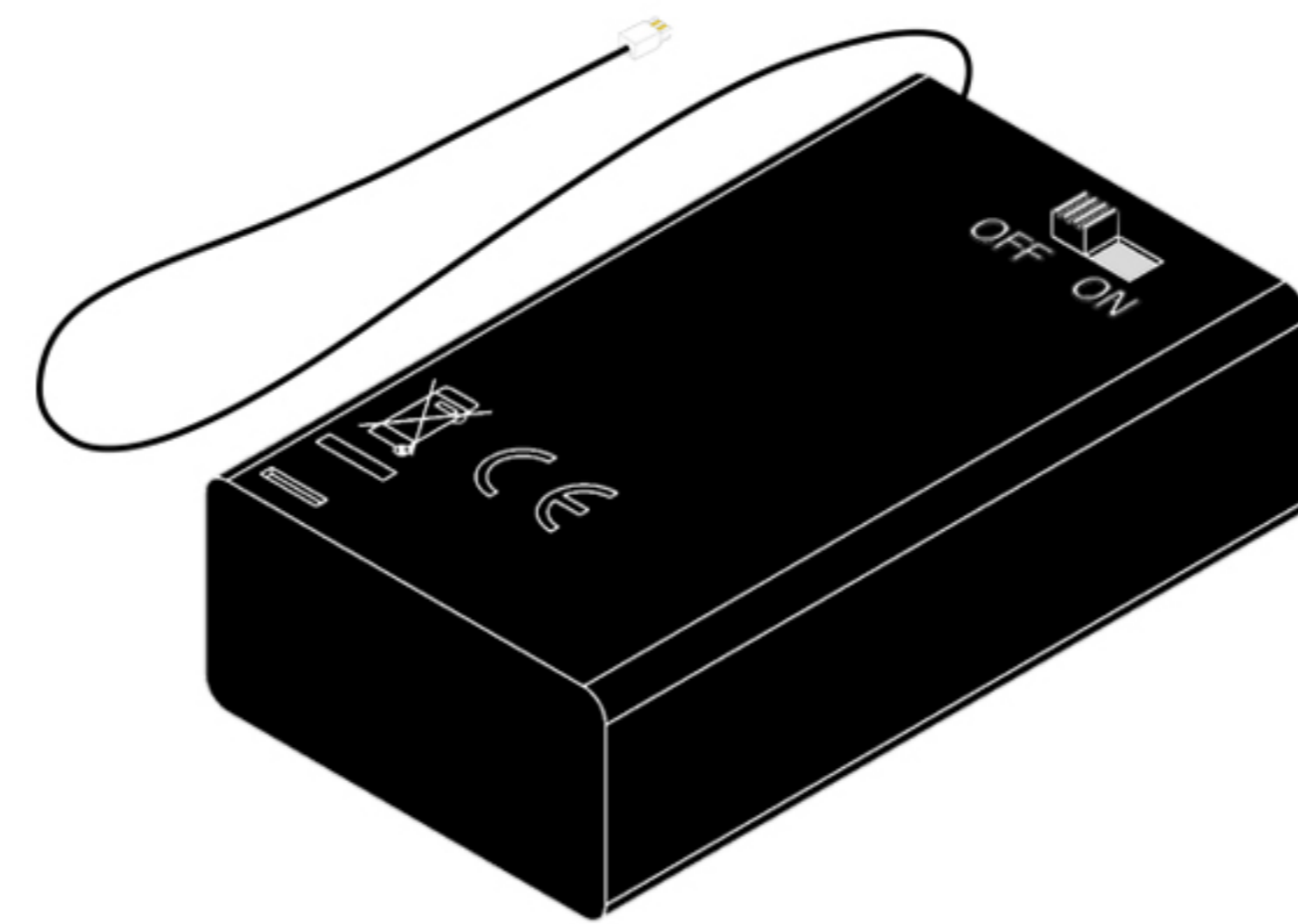

(X1)

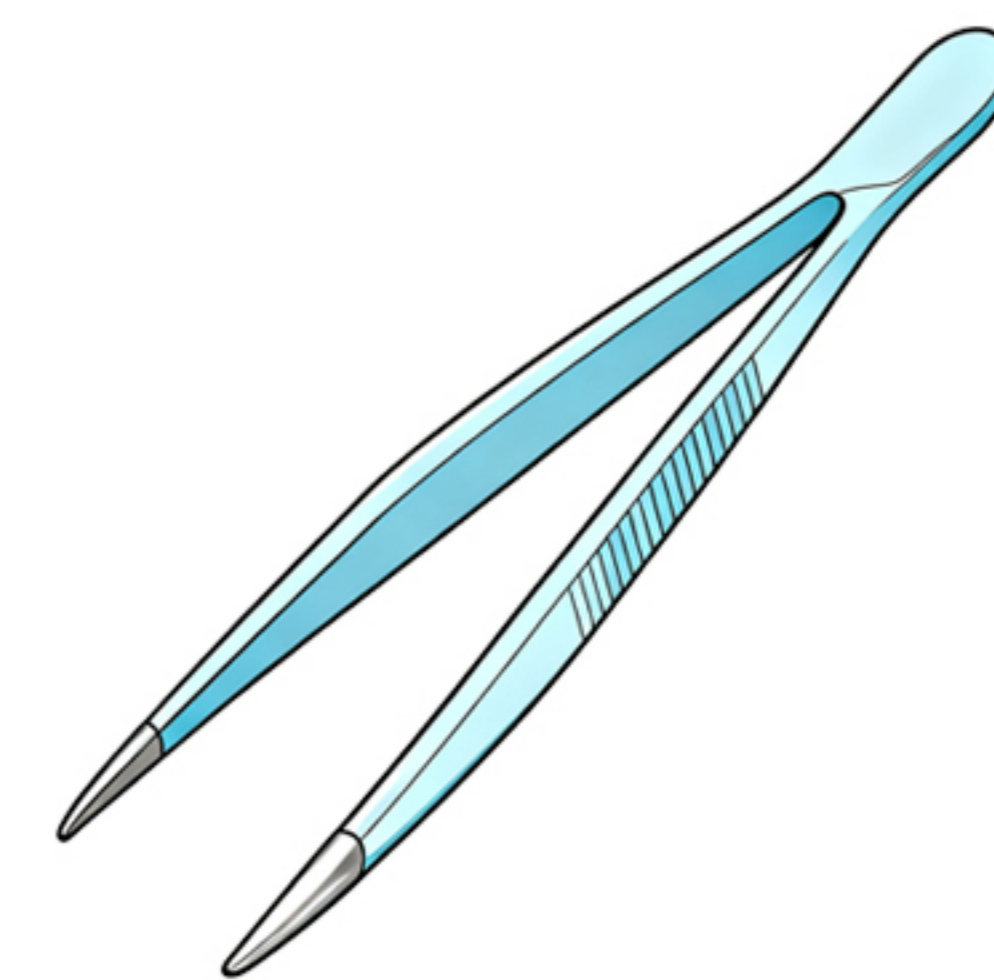

(X1)

This post will complete the light installation in two main sections.

Step 1-test



Step 2-mounting

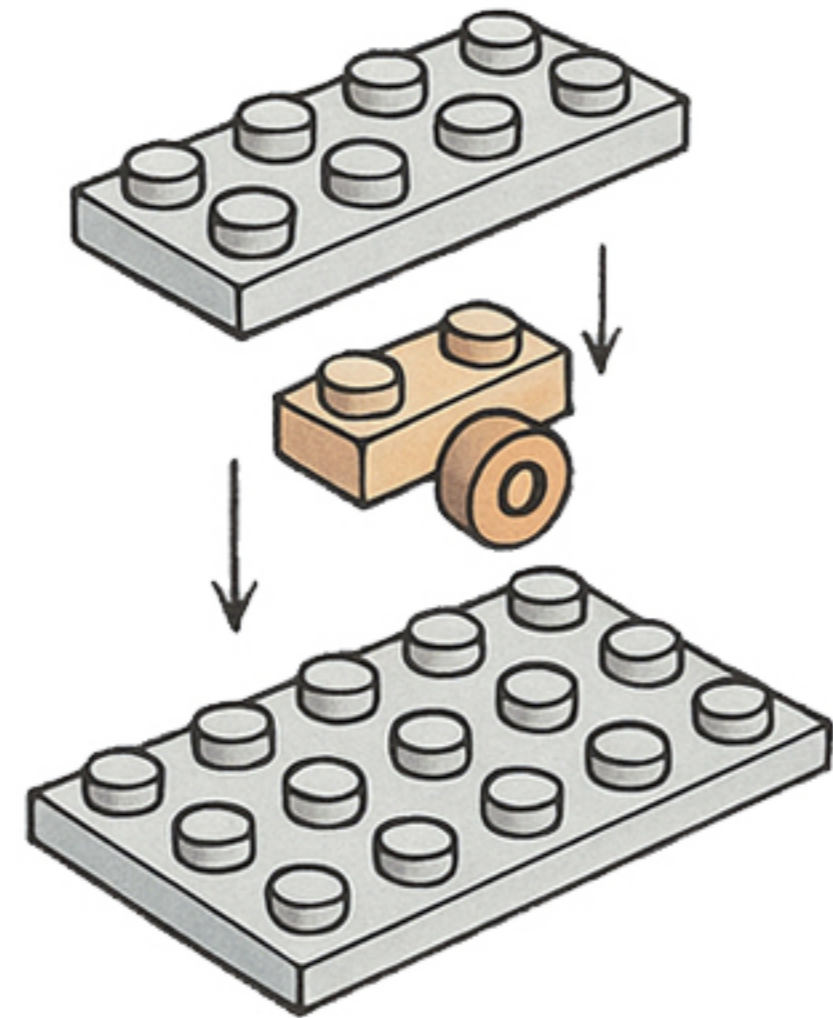

So let's get started!

Step 1-Test.

1

EN: Remove the expansion board from Bag 5.

DE: Entnehmen Sie die Erweiterungskarte aus Beutel 5.

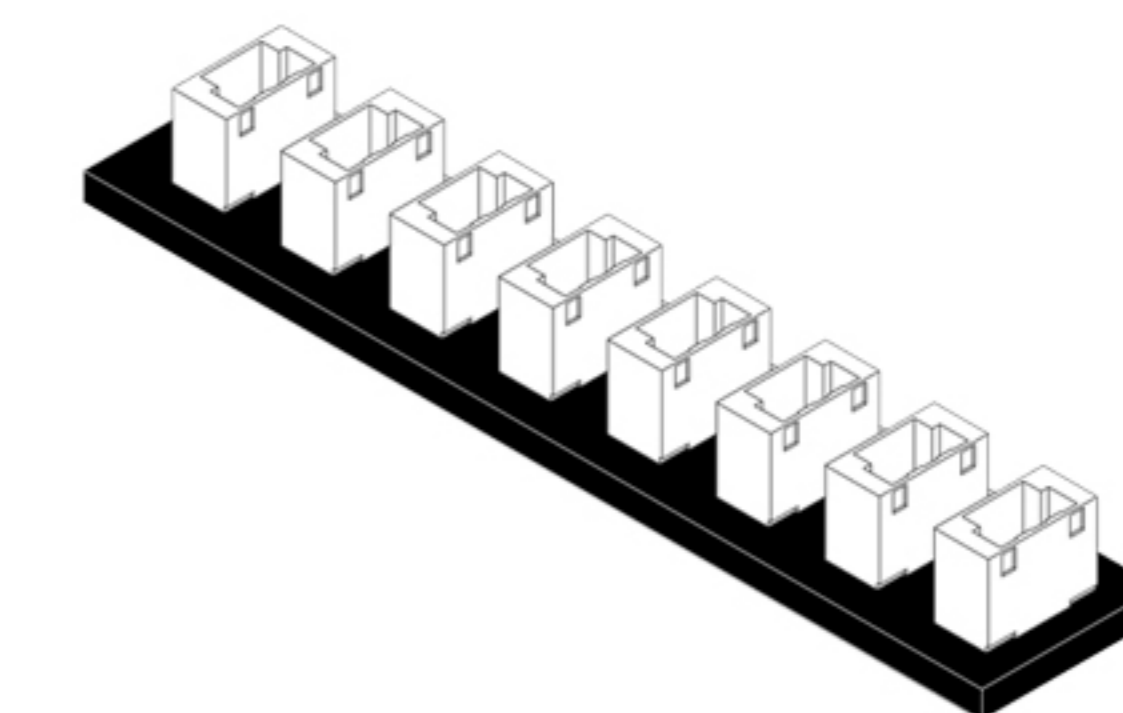

x1

2

EN: Take the USB power cable out of the box and connect it to the expansion board.

DE: Nehmen Sie das USB-Stromkabel aus der Verpackung und schließen Sie es an die Erweiterungskarte an.

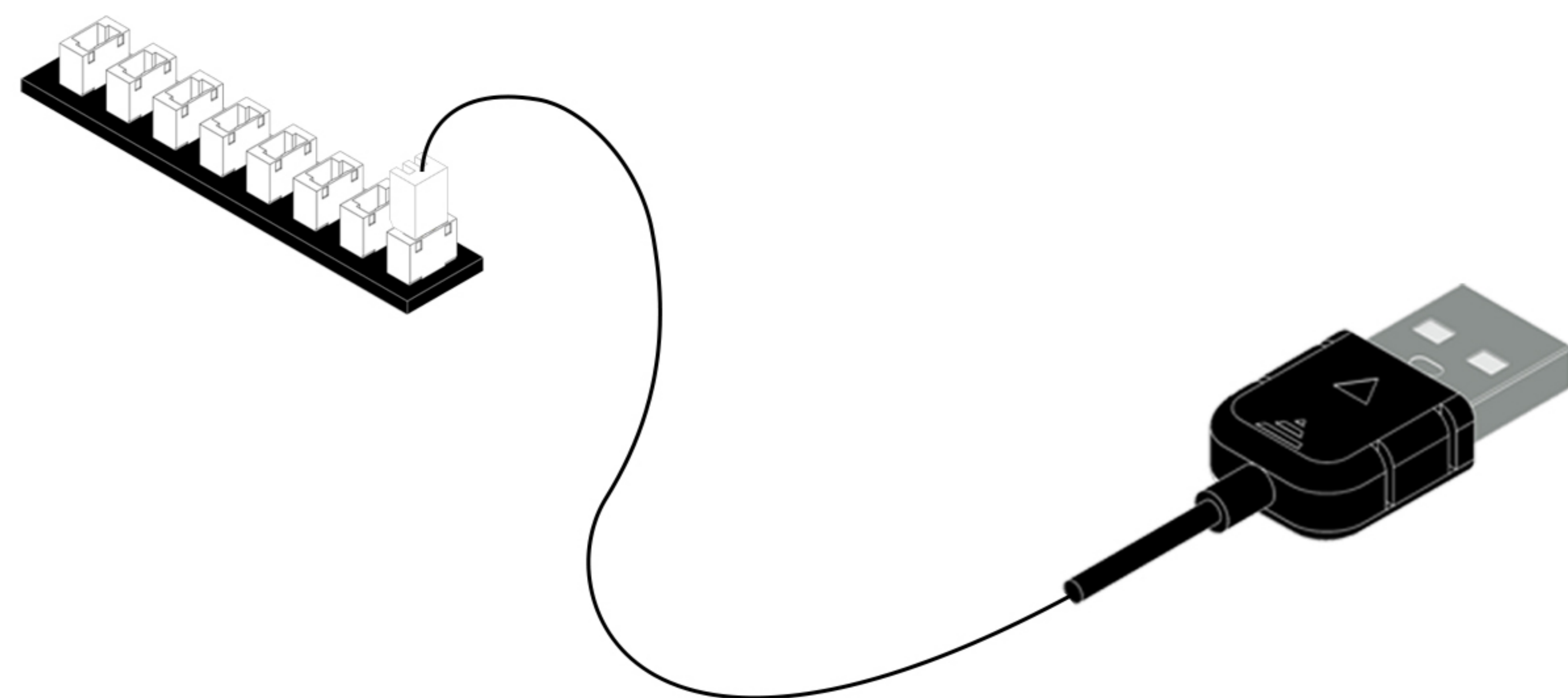
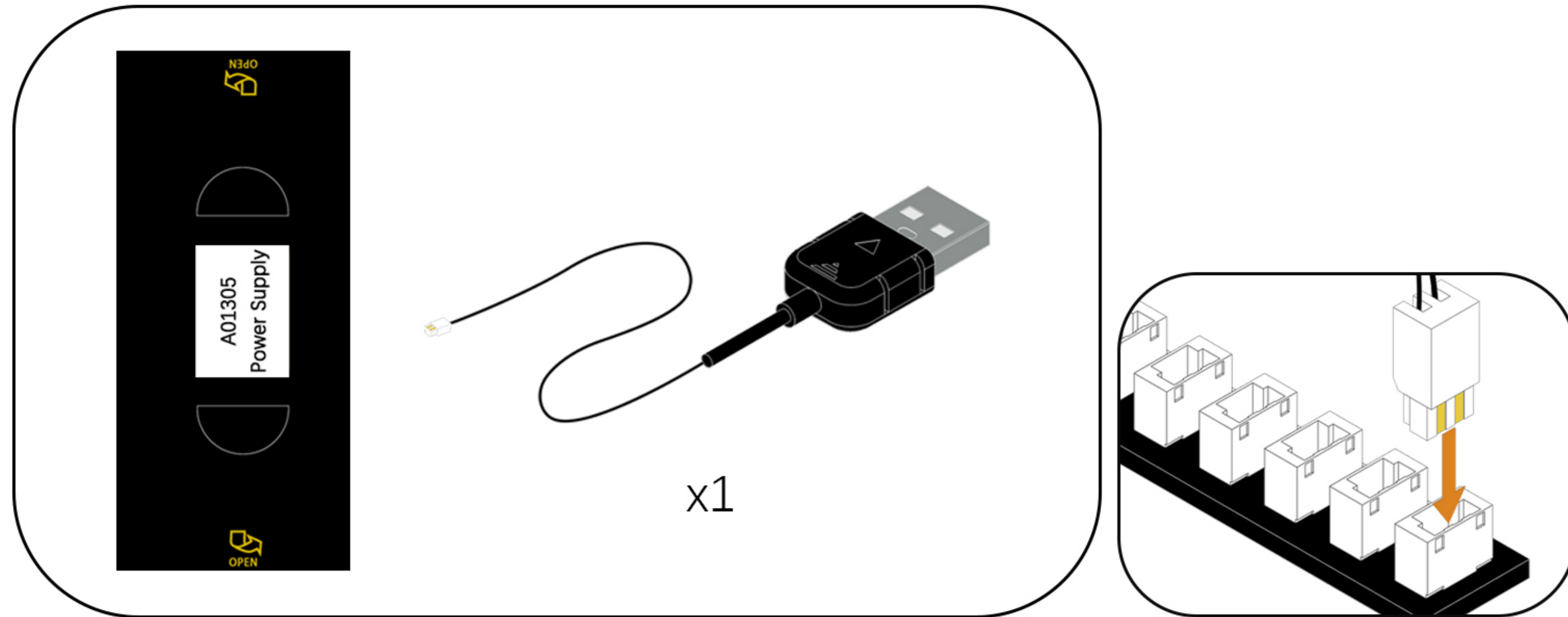

3

EN: Connect the USB power cable to the mobile power supply. (Power supply not included, see the diagram below for power supply options.)

DE: Schließen Sie das USB-Netz-kabel an die mobile Stromversorgung an. (Stromversorgung nicht im Lieferumfang enthalten, siehe Abbildung unten für die Stromversorgungsart.)

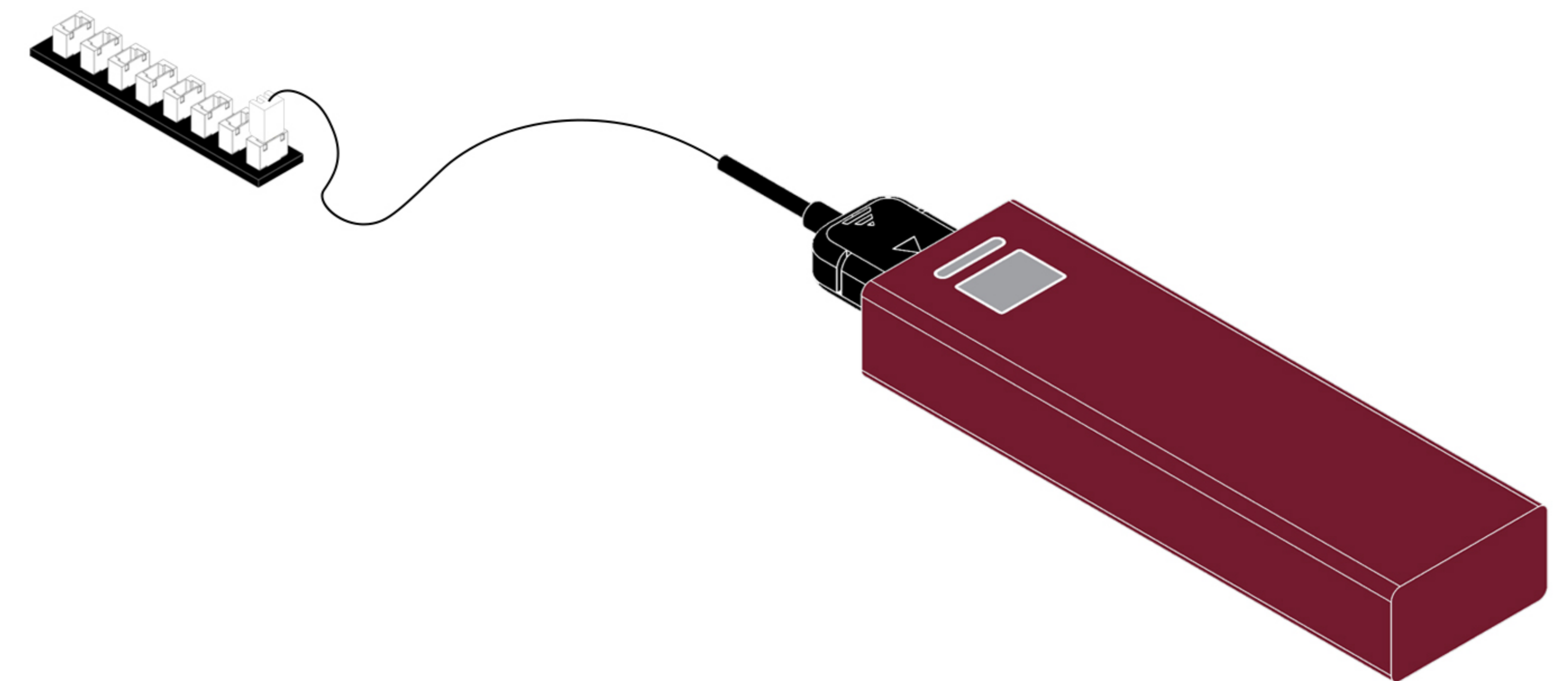

USB Connectors to Connect Devices

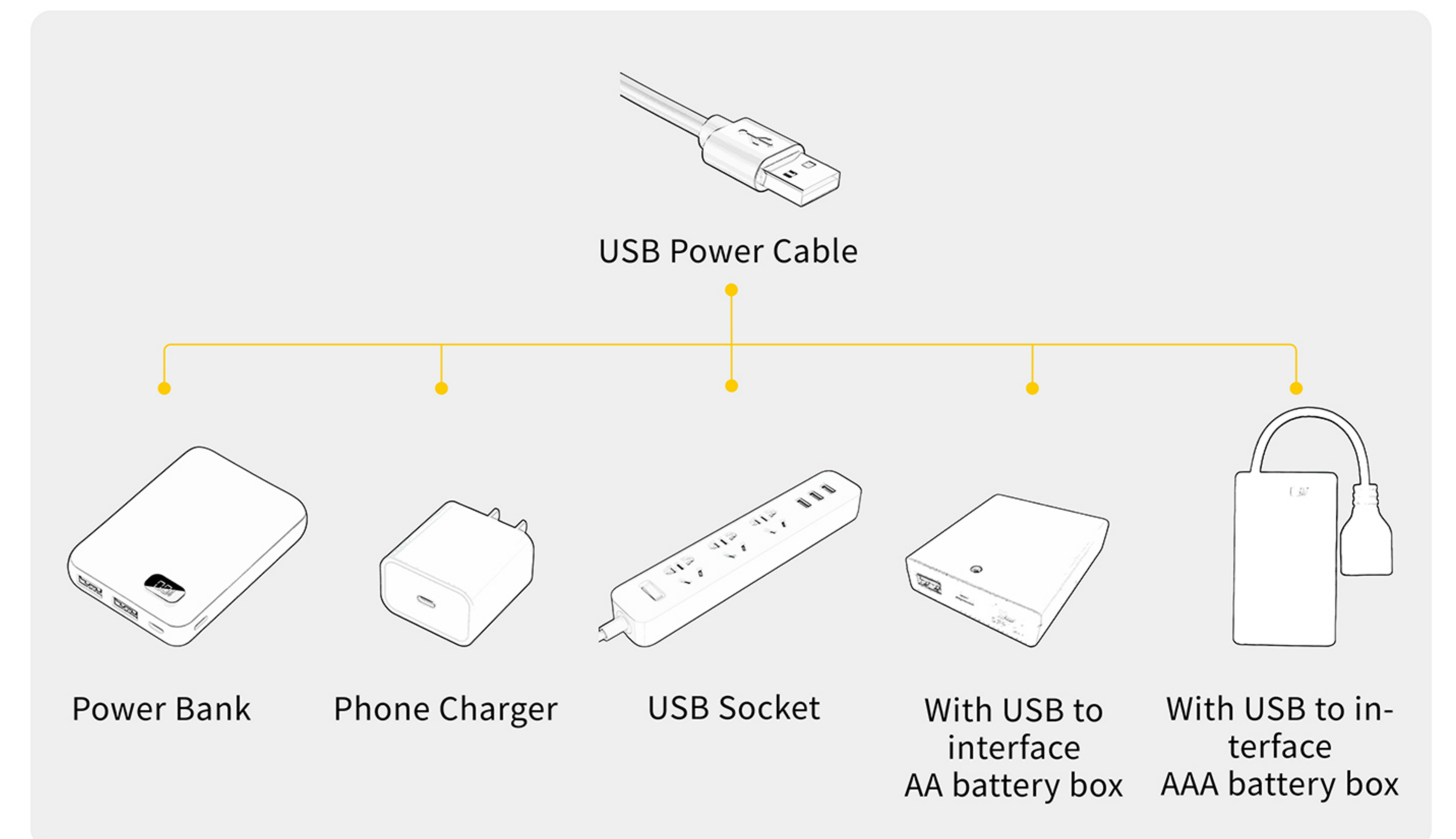

4

EN: Remove the string of lights from Bag 1, connect it to the expansion board, turn on the power, and check that the lights are working properly. If you notice any issues, please contact us immediately.

DE: Nehmen Sie die Lichterkette aus Beutel 1, schließen Sie sie an die Erweiterungskarte an, schalten Sie den Strom ein und überprüfen Sie, ob die Lichter ordnungsgemäß funktionieren. Sollten Sie Probleme feststellen, kontaktieren Sie uns bitte umgehend.

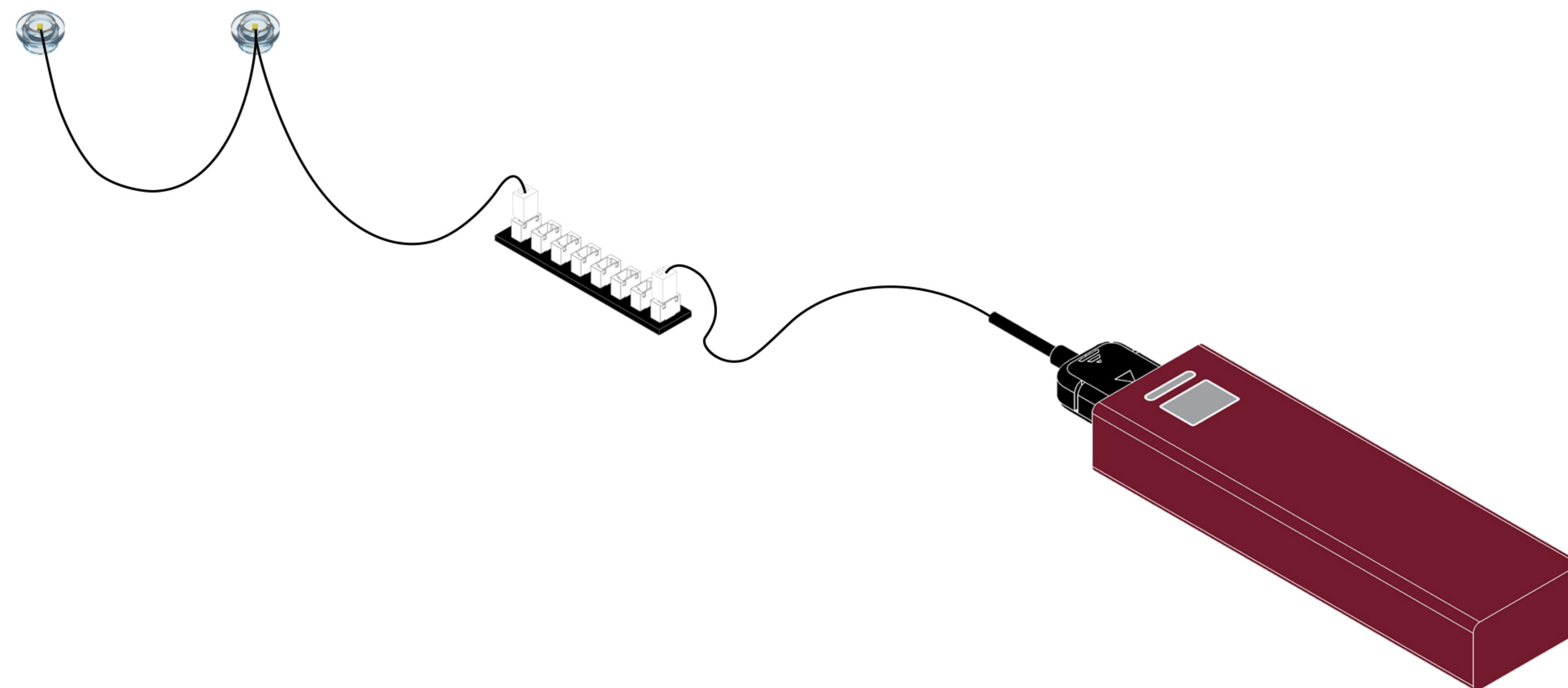
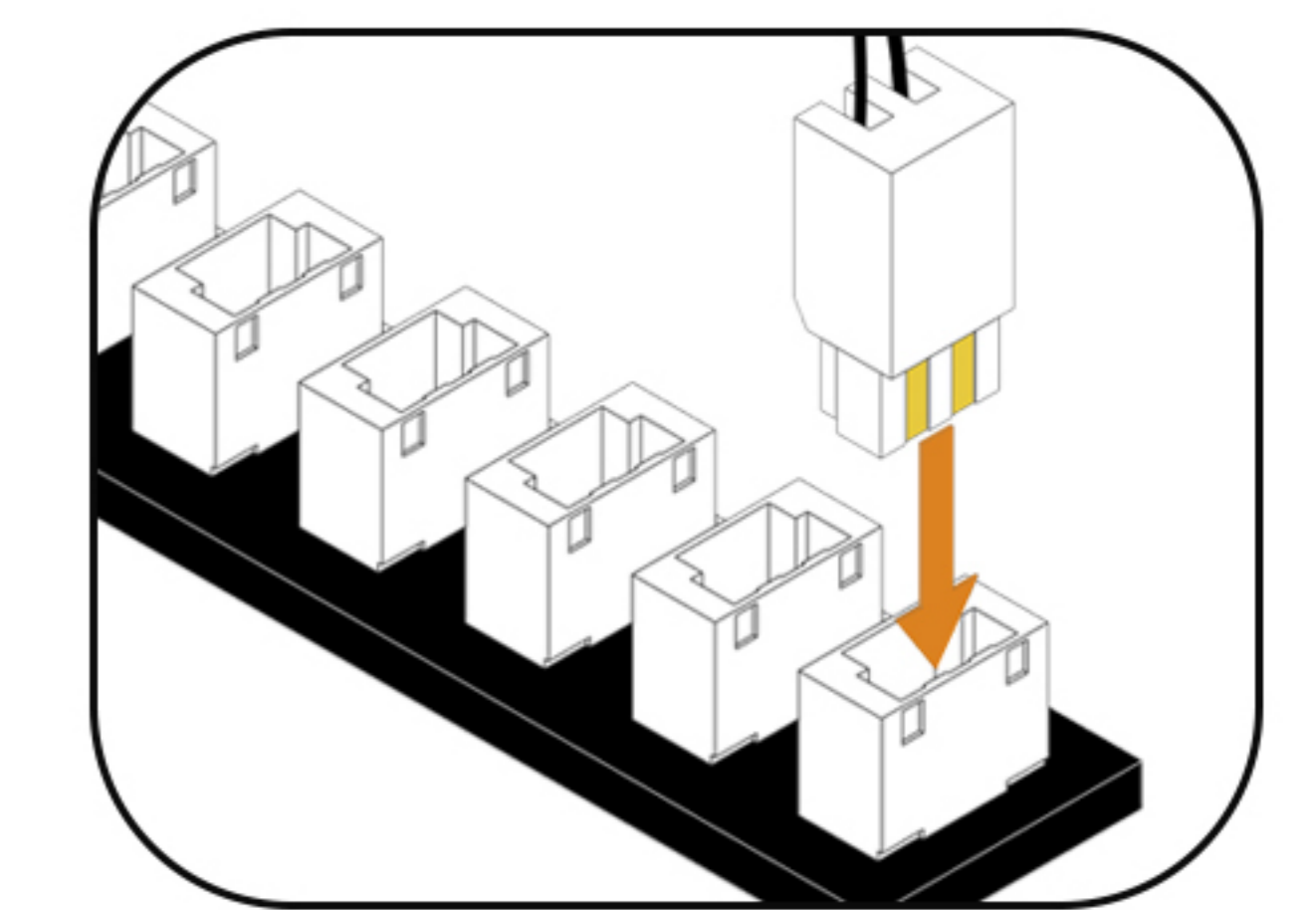
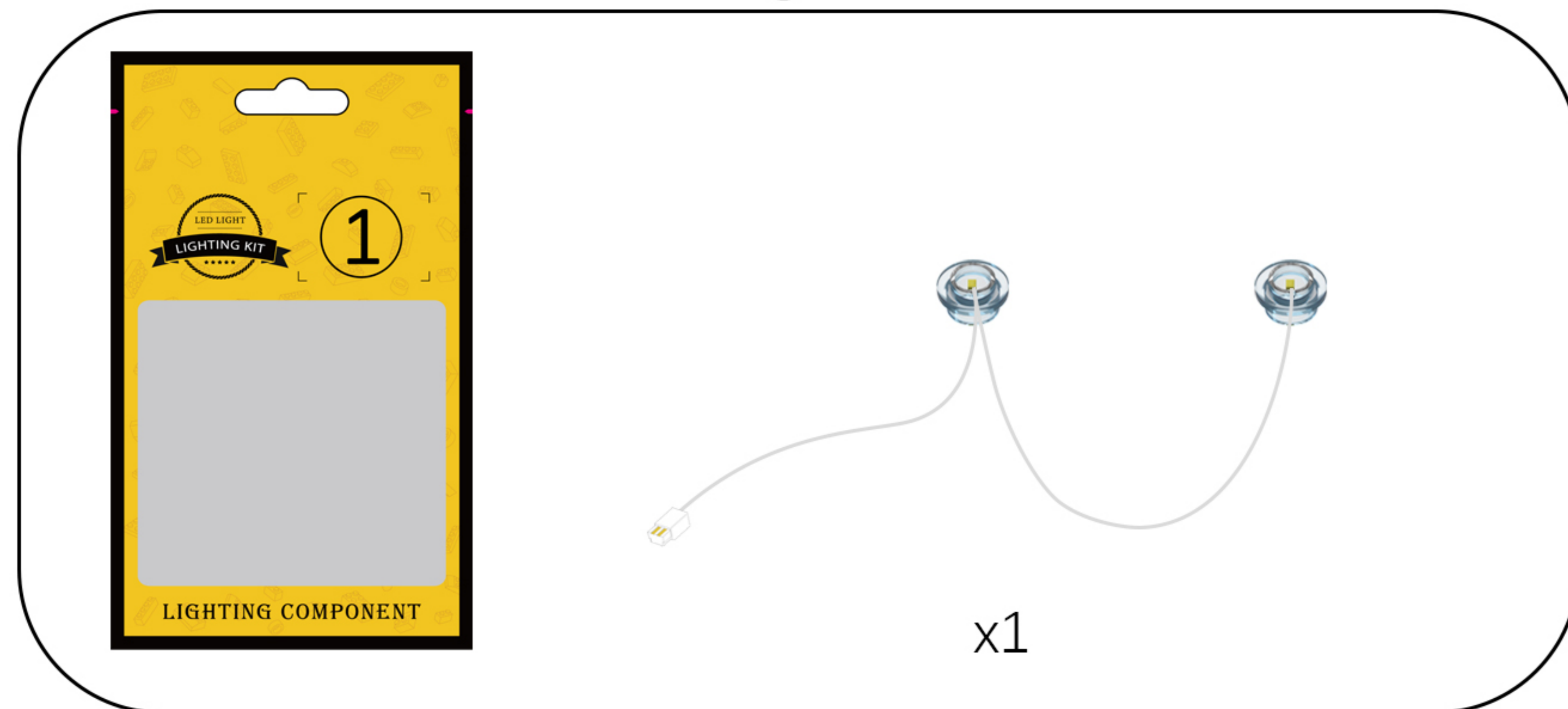

Once you've confirmed there are no issues, put the string lights back in their original bag, then test them.

5

EN: Remove the LED strip from Bag 4, connect it to the expansion board, turn on the power, and check that the LED strip is working properly. If you notice any issues, please contact us immediately.

DE: Nehmen Sie den LED-Streifen aus Beutel 4, schließen Sie ihn an die Erweiterungsplatine an, schalten Sie die Stromversorgung ein und überprüfen Sie, ob der LED-Streifen ordnungsgemäß funktioniert. Sollten Sie Probleme feststellen, kontaktieren Sie uns bitte umgehend.

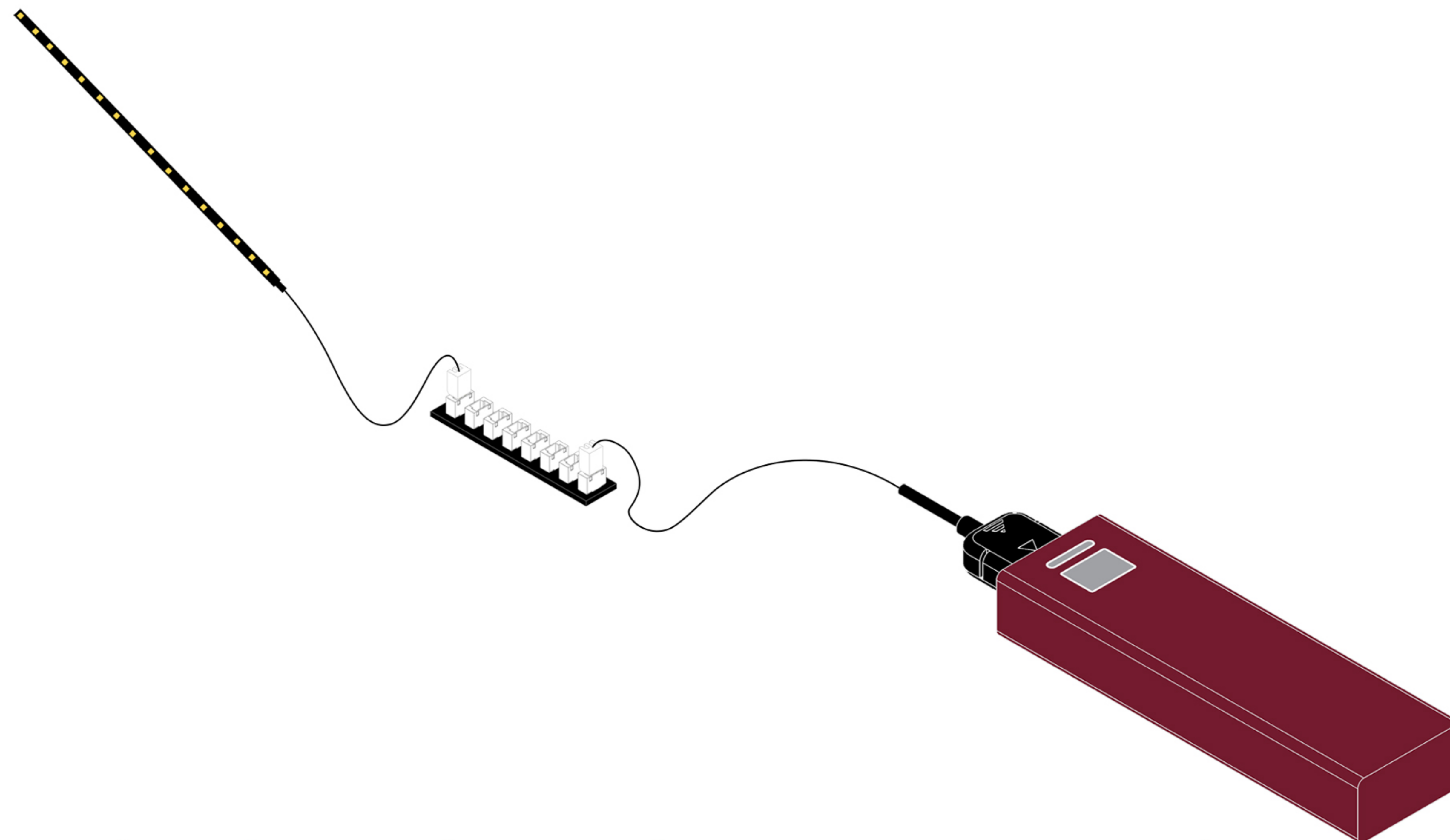
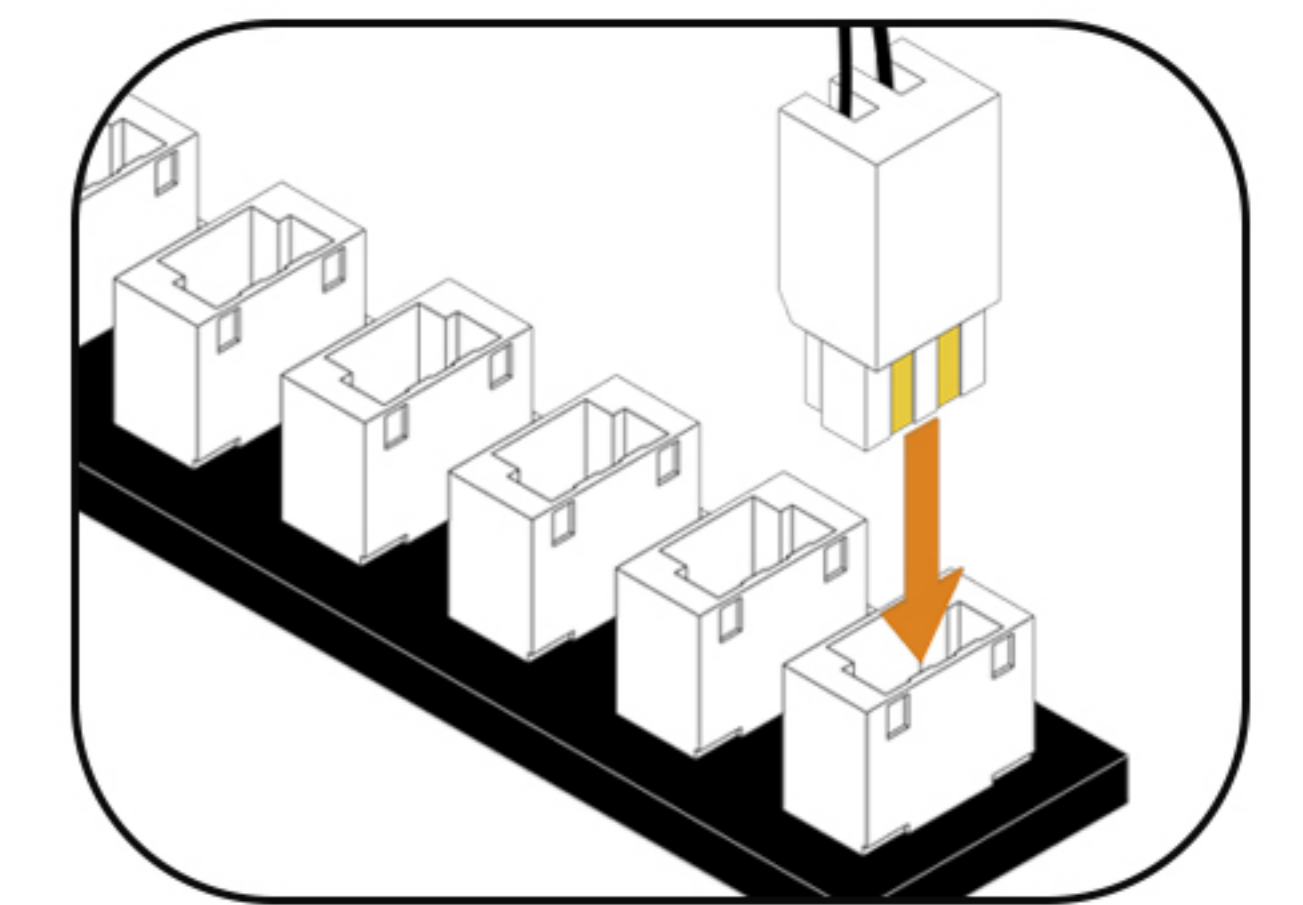
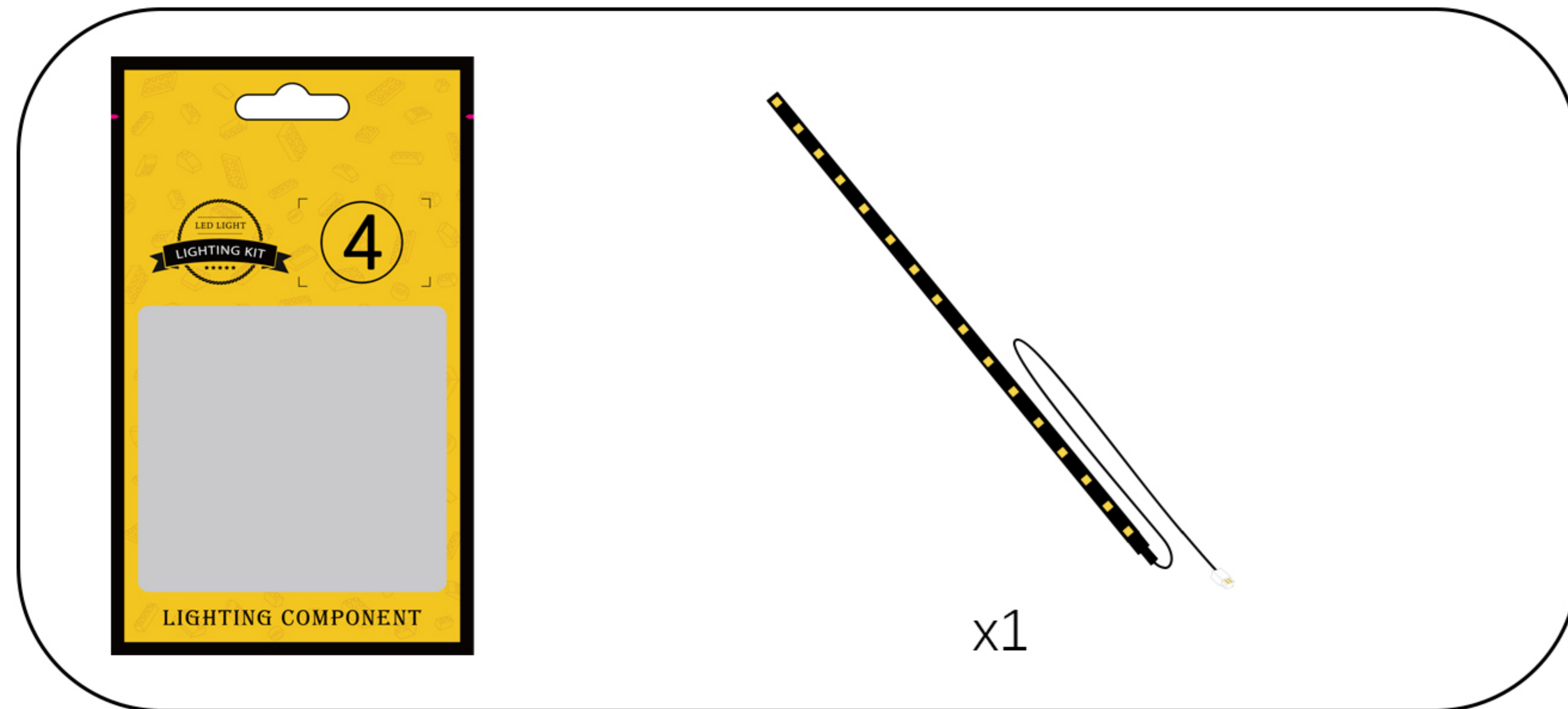

After confirming that there are no abnormalities, temporarily return each part to its original bag.

Step 2-Mounting.

1

EN: Take out the building block model.

DE: Nimm das Bauklotzmodell heraus.



2

EN: Remove the building blocks one by one.

DE: Entfernen Sie die Bausteine nacheinander.

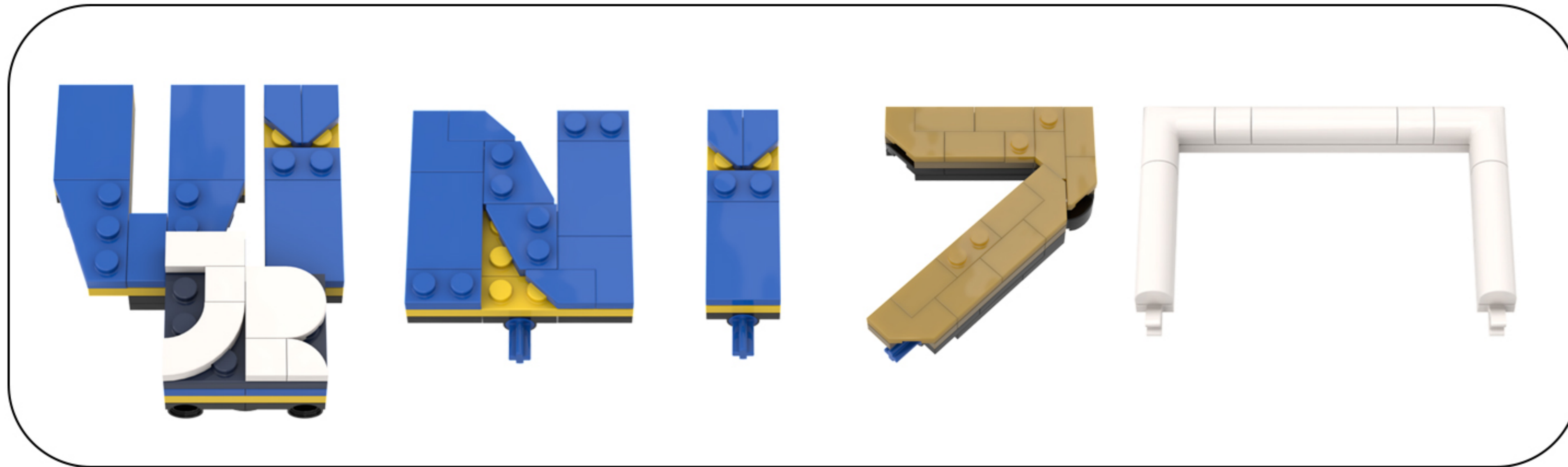

3

EN: Take the string lights out of Bag 2 and remove the disassembled building blocks.

DE: Nimm die Lichterkette aus Beutel 2 heraus und entferne die zerlegten Bausteine.

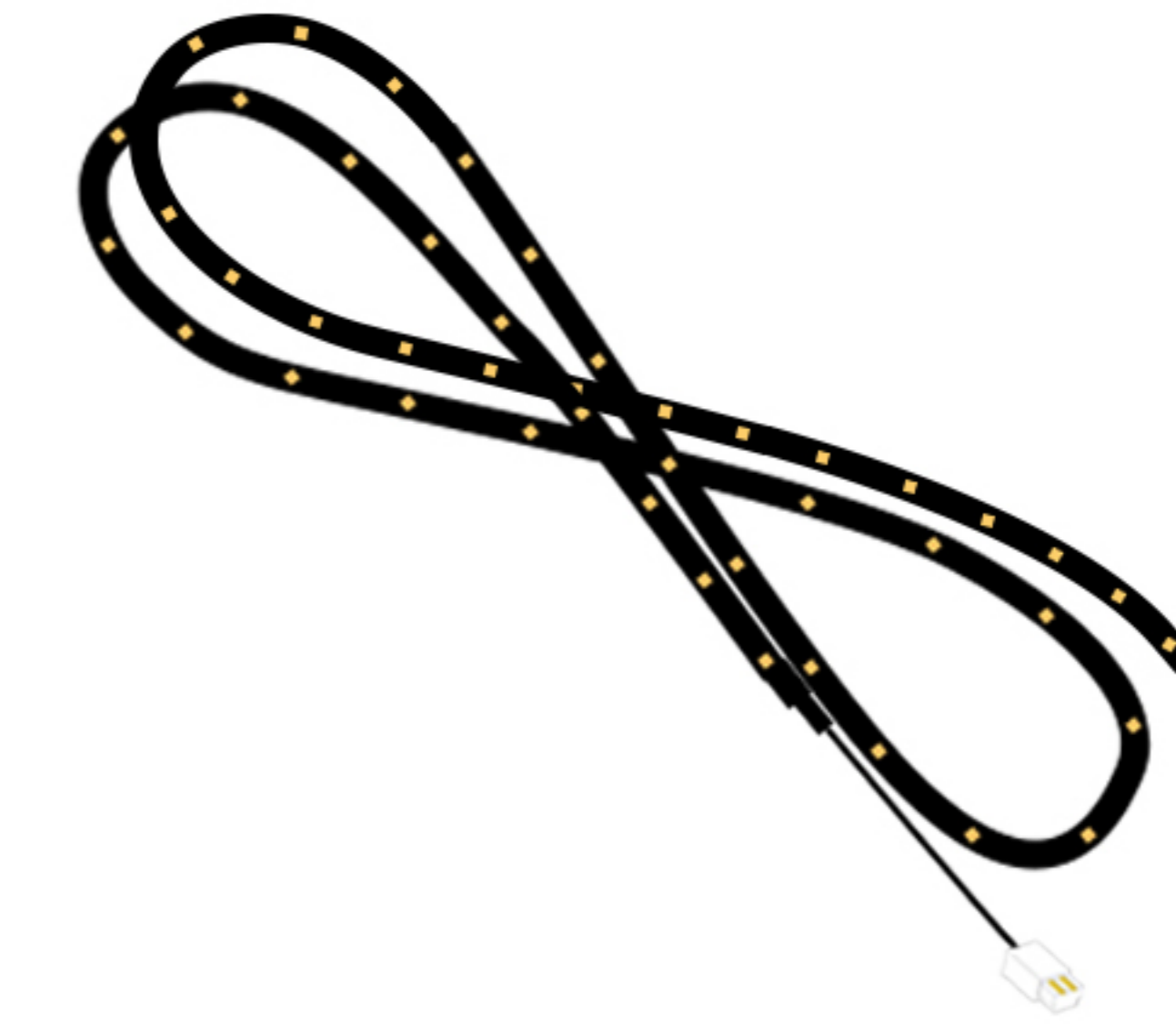
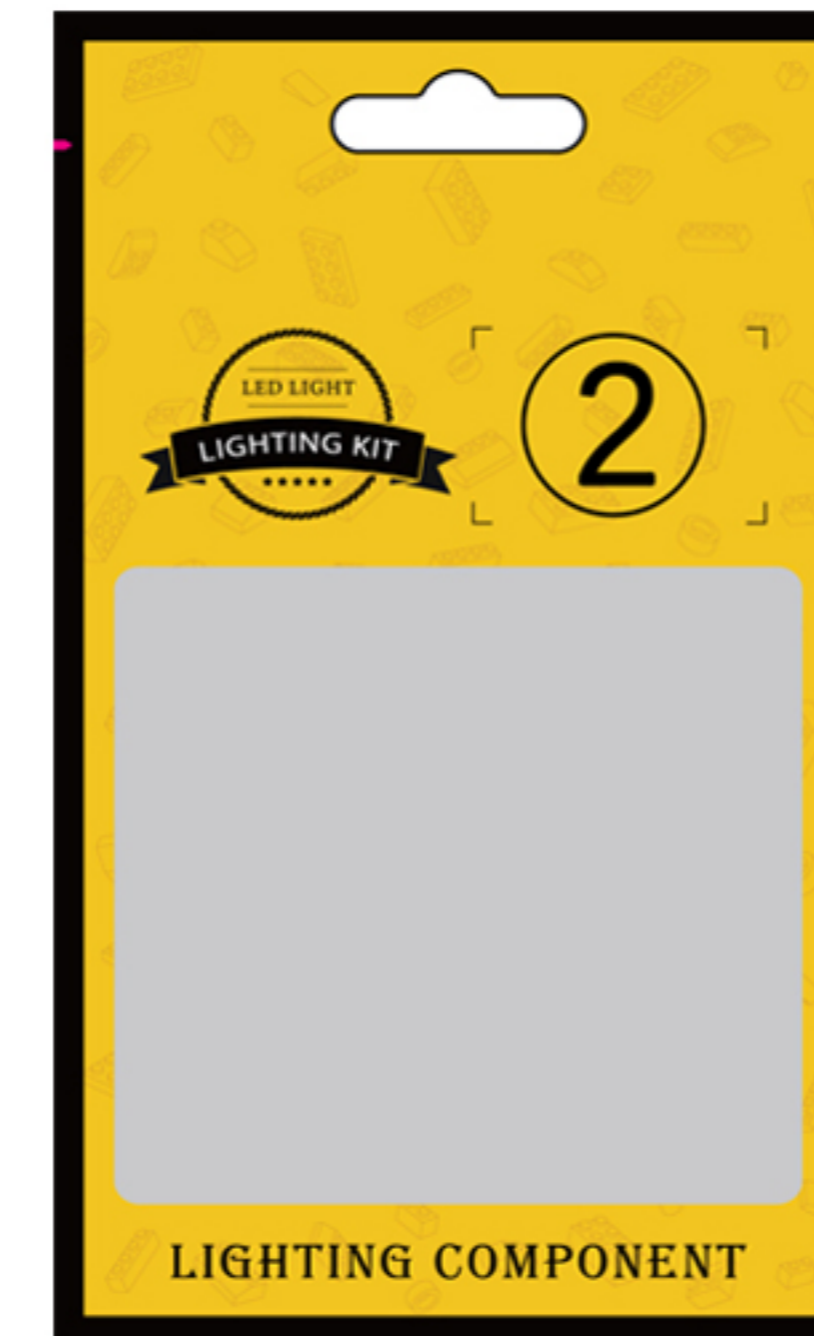

x1



x1

4

EN: Peel off the adhesive backing from the light strip and wrap it around the building block.

DE: Zieh die Schutzfolie vom Leuchtband ab und wickle es um den Baustein.

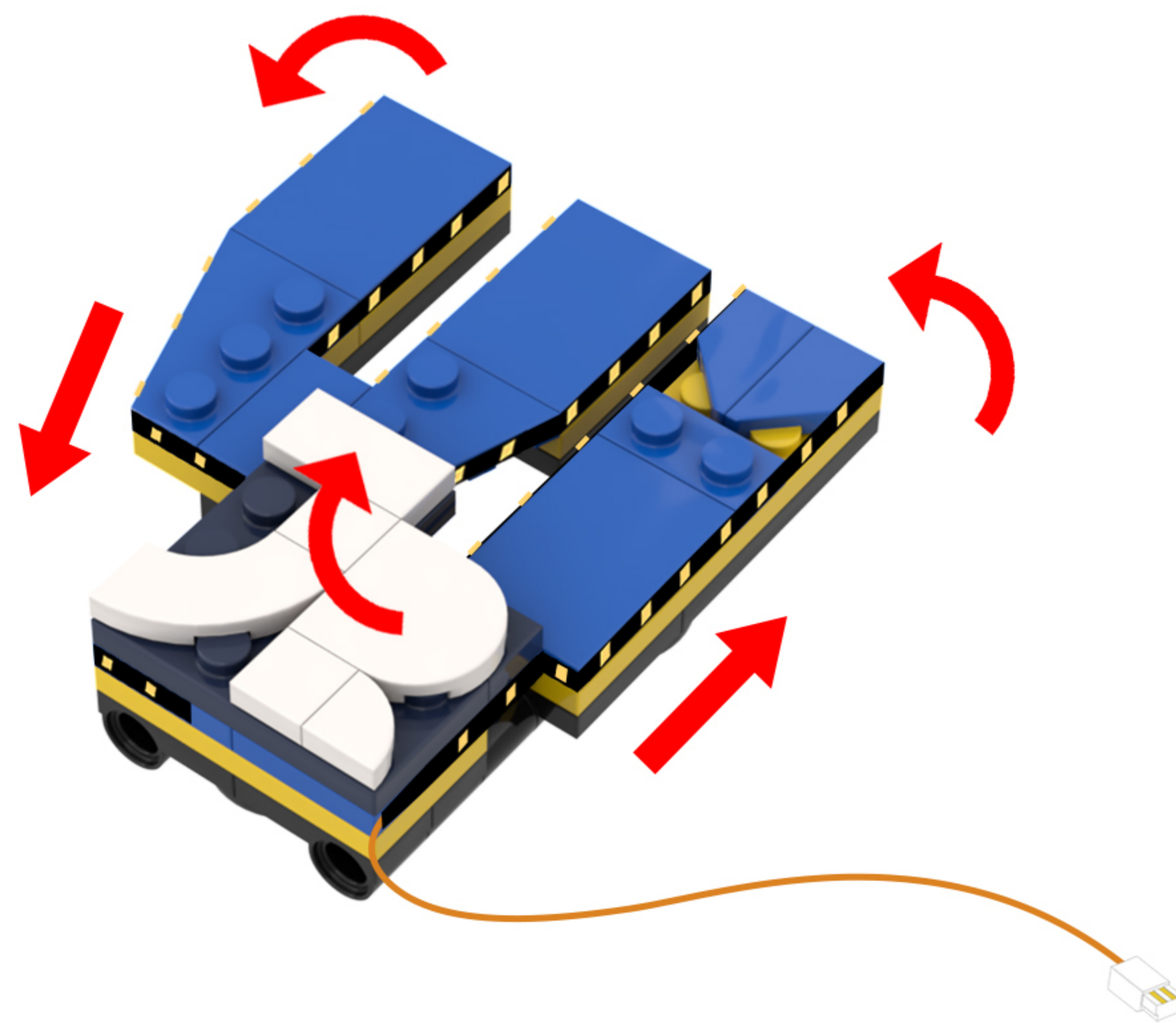
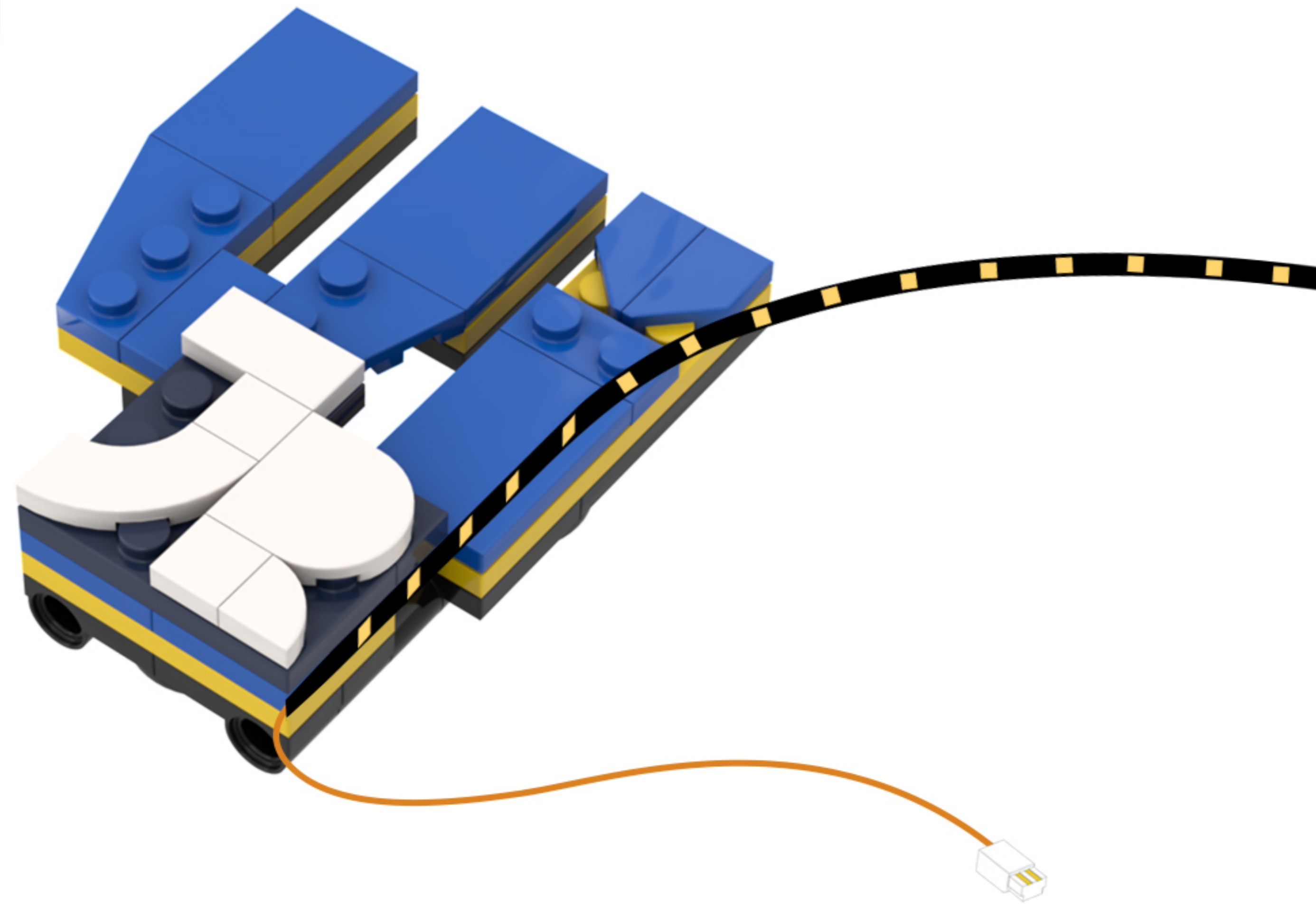

5

EN: Rotate the model to its back side.

DE: Drehen Sie das Modell auf die Rückseite.

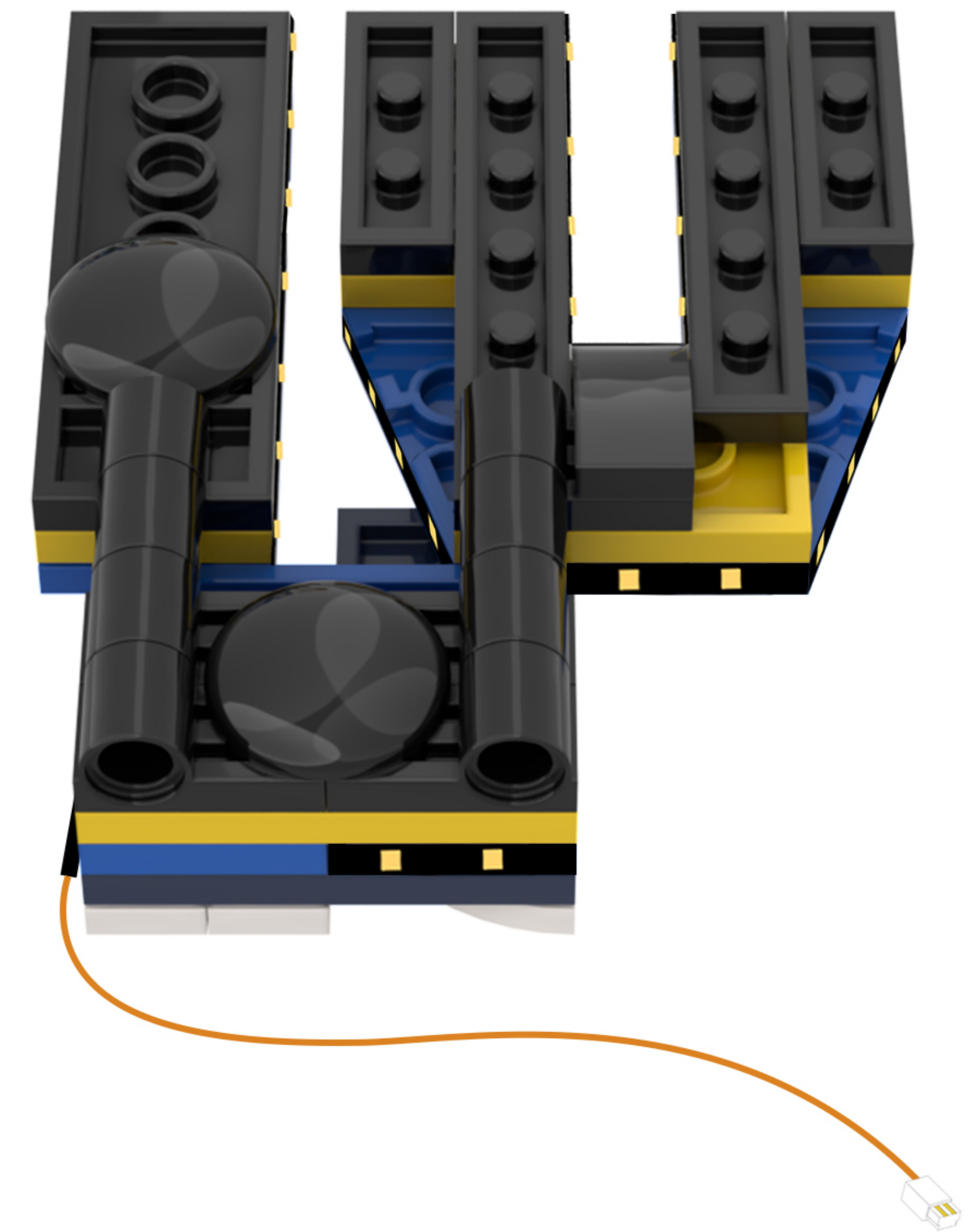

6

EN: Split as shown in the figure.

DE: Wie in der Abbildung gezeigt, teilen Sie es auf.

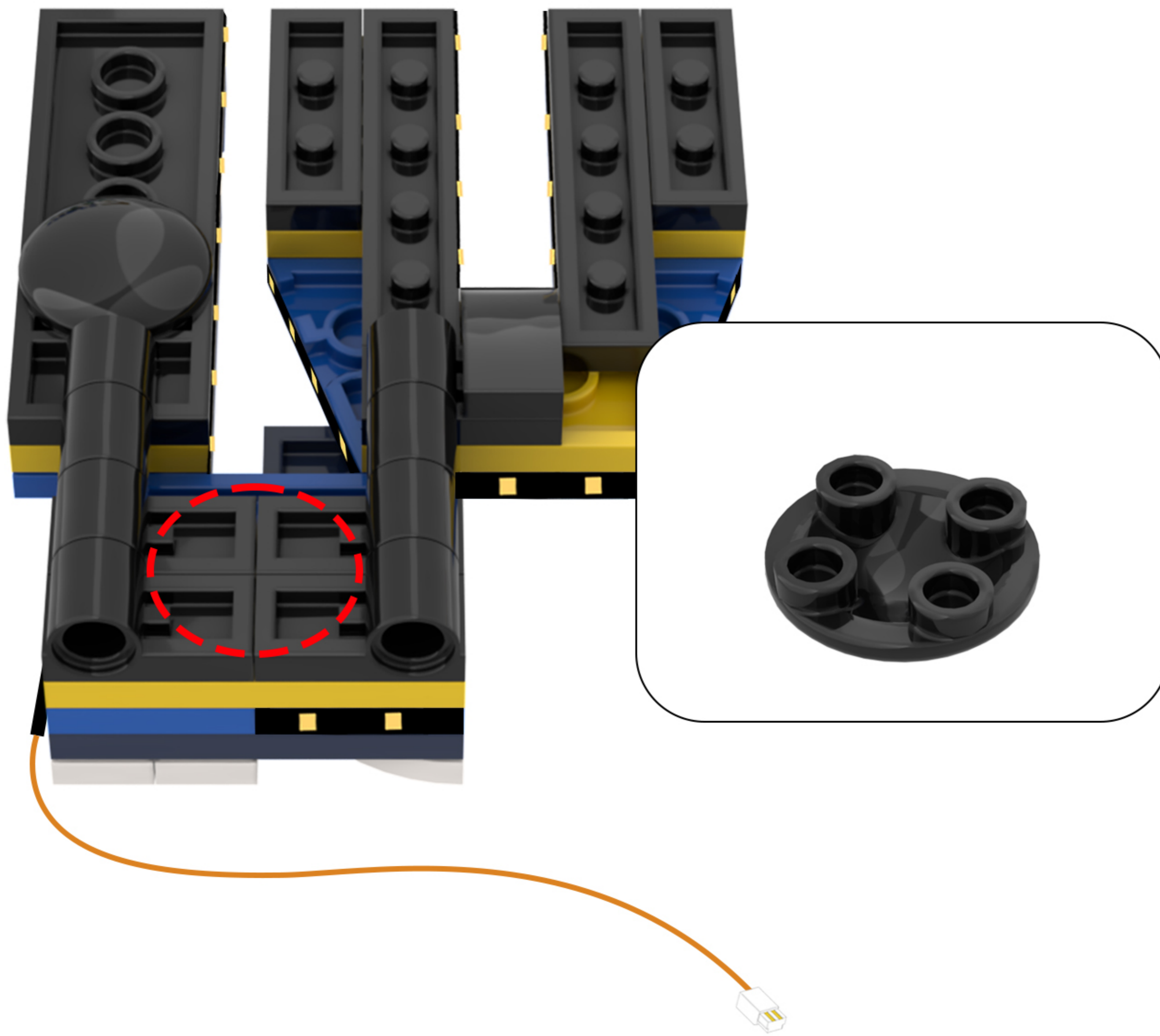

7

EN: Arrange the lighting lines according to the diagram.

DE: Ordnen Sie die Beleuchtungslinien gemäß der Abbildung an.

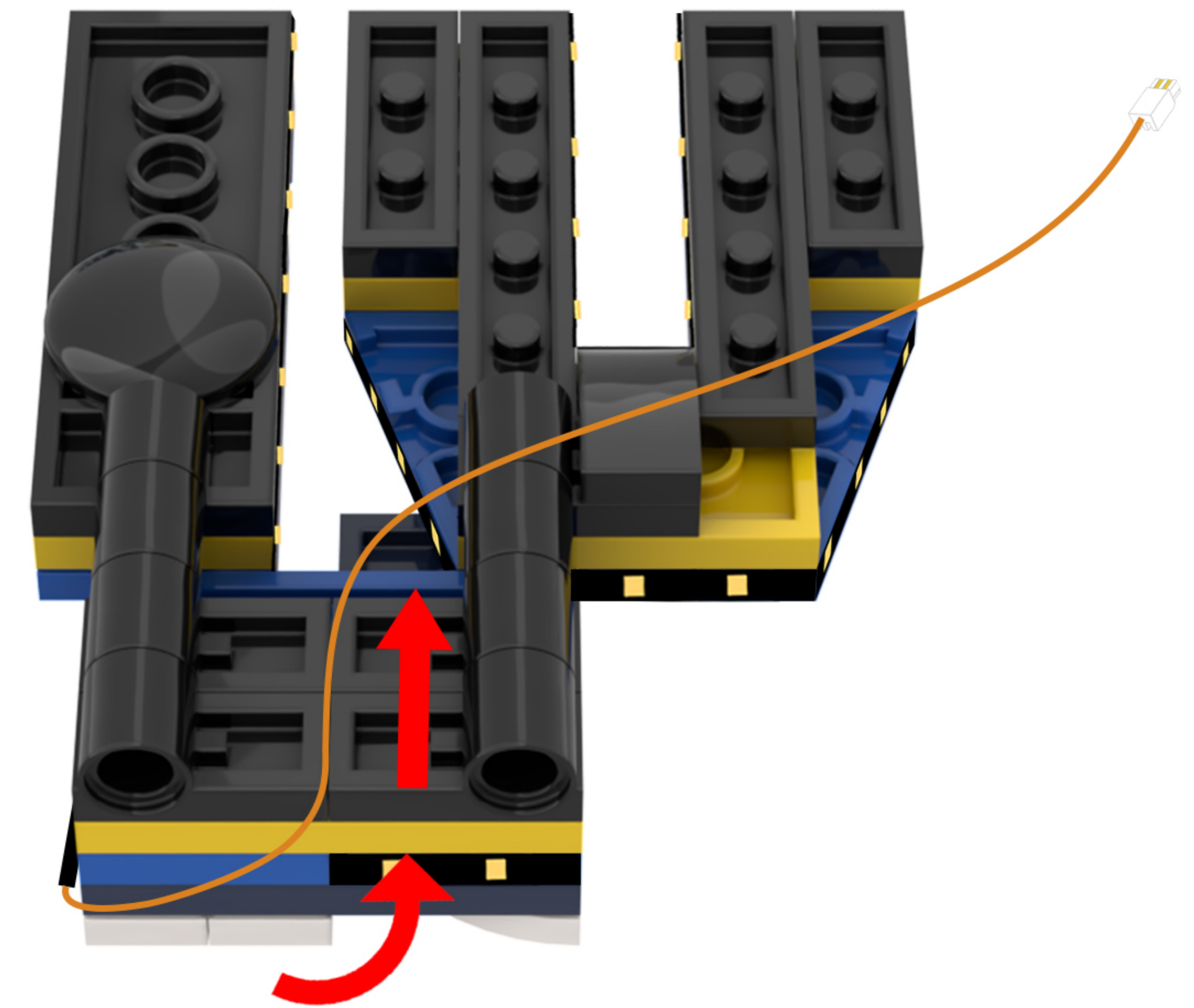

8

EN: Take out the disassembled building blocks, reassemble them, and secure the light cord.

DE: Nehmen Sie die zerlegten Bausteine heraus, setzen Sie sie wieder zusammen und befestigen Sie das Lichtkabel.

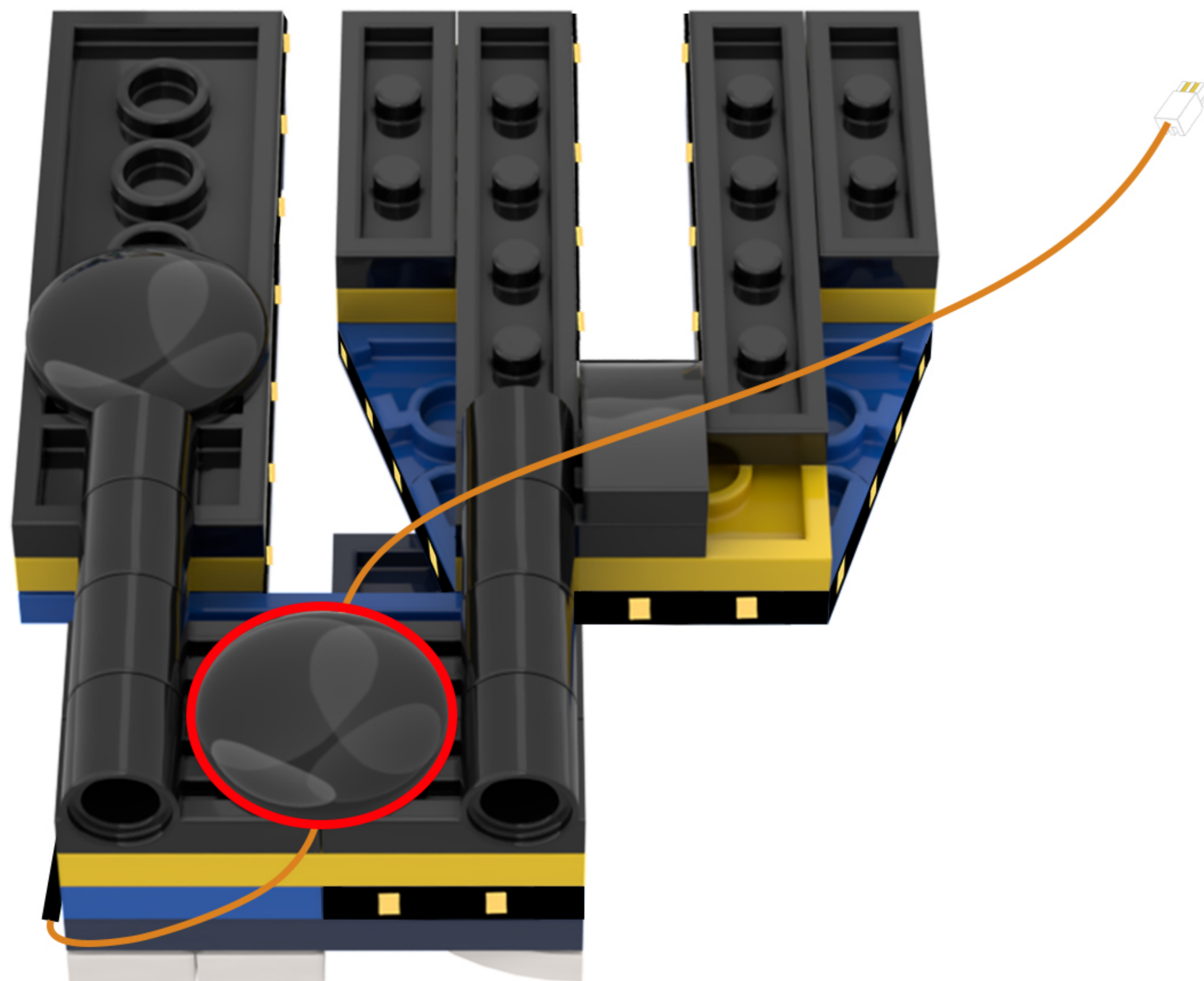
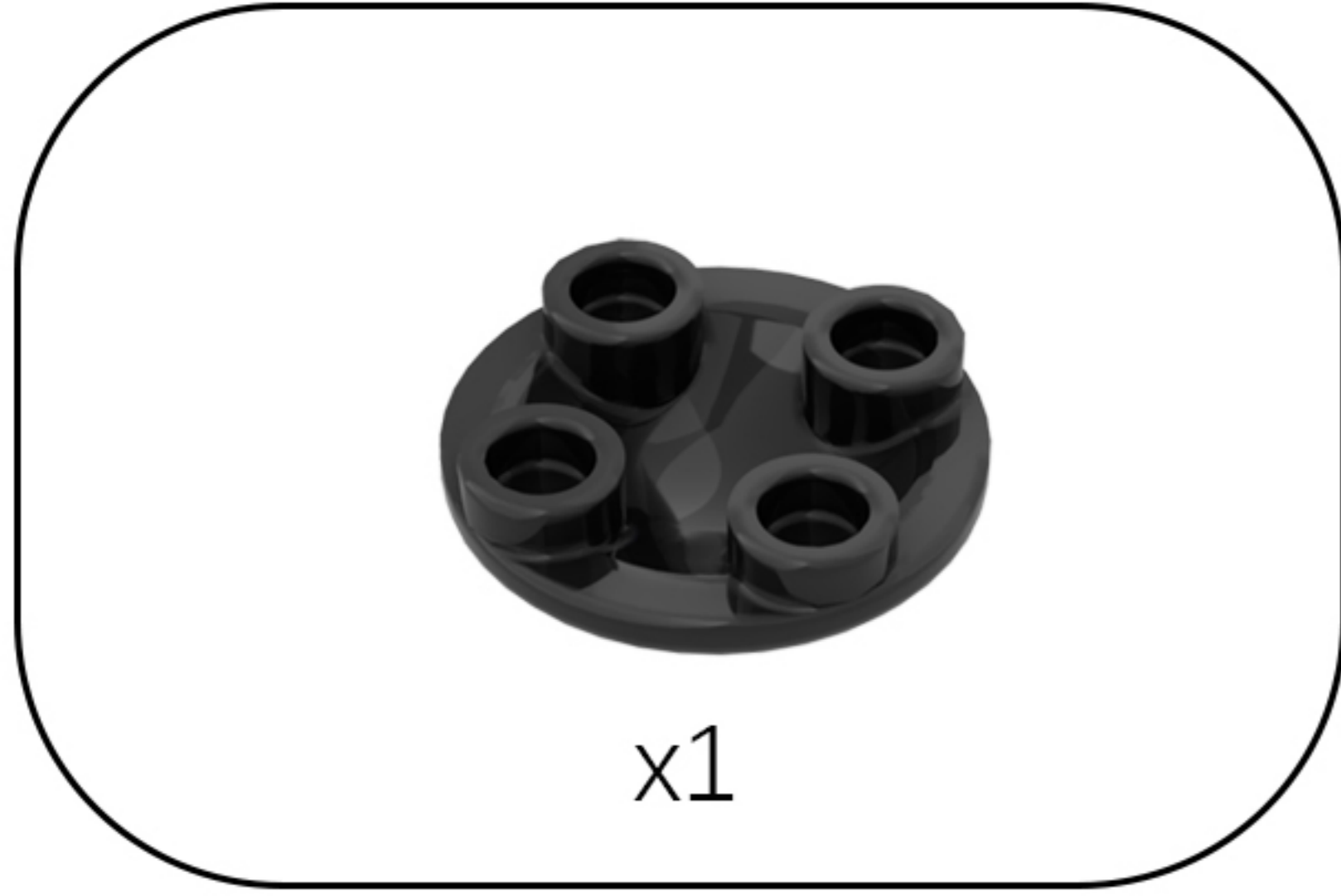

9

EN: Take the string lights out of Bag 3 and remove the disassembled building blocks.

DE: Nimm die Lichterkette aus Beutel 3 heraus und entferne die zerlegten Bausteine.

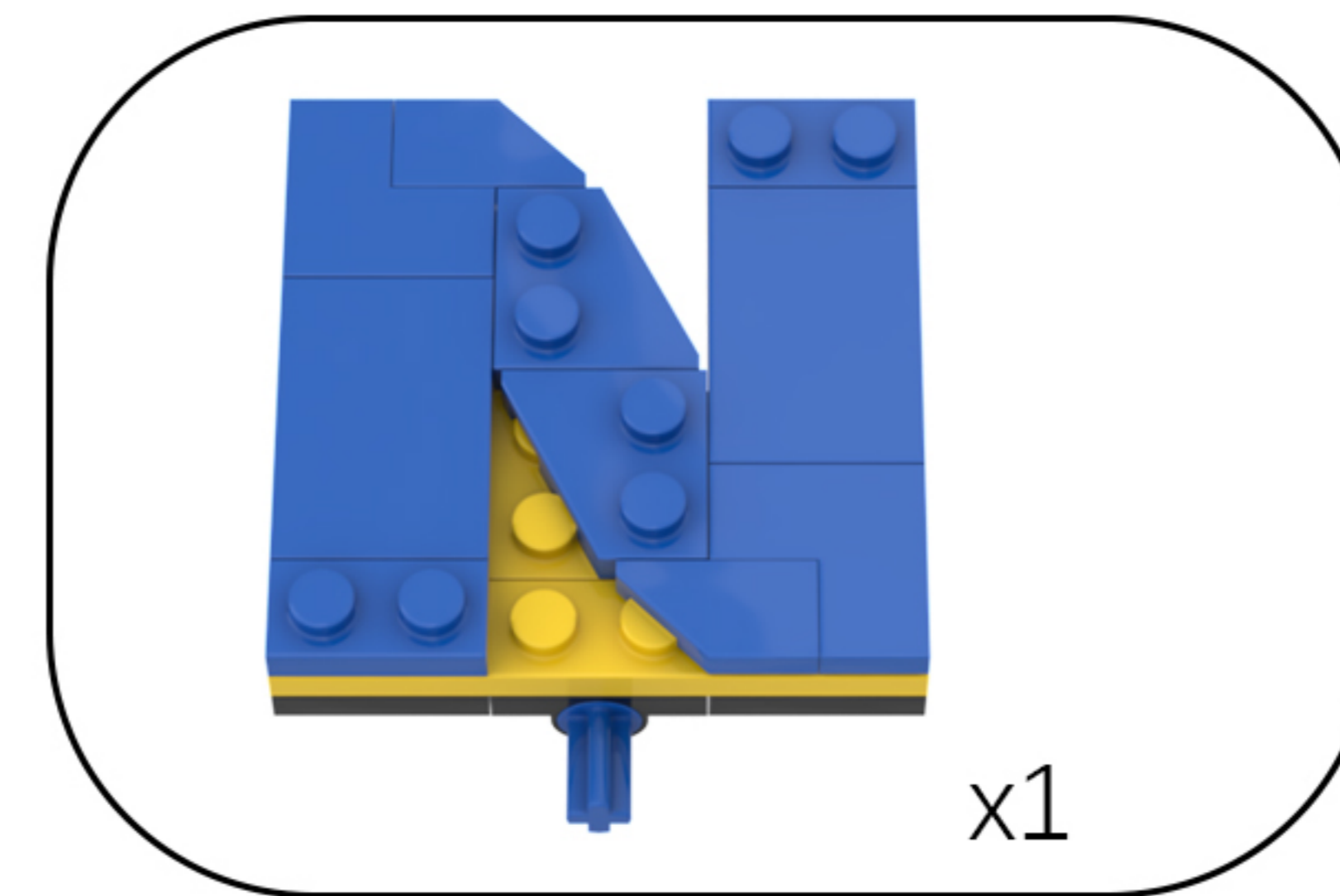
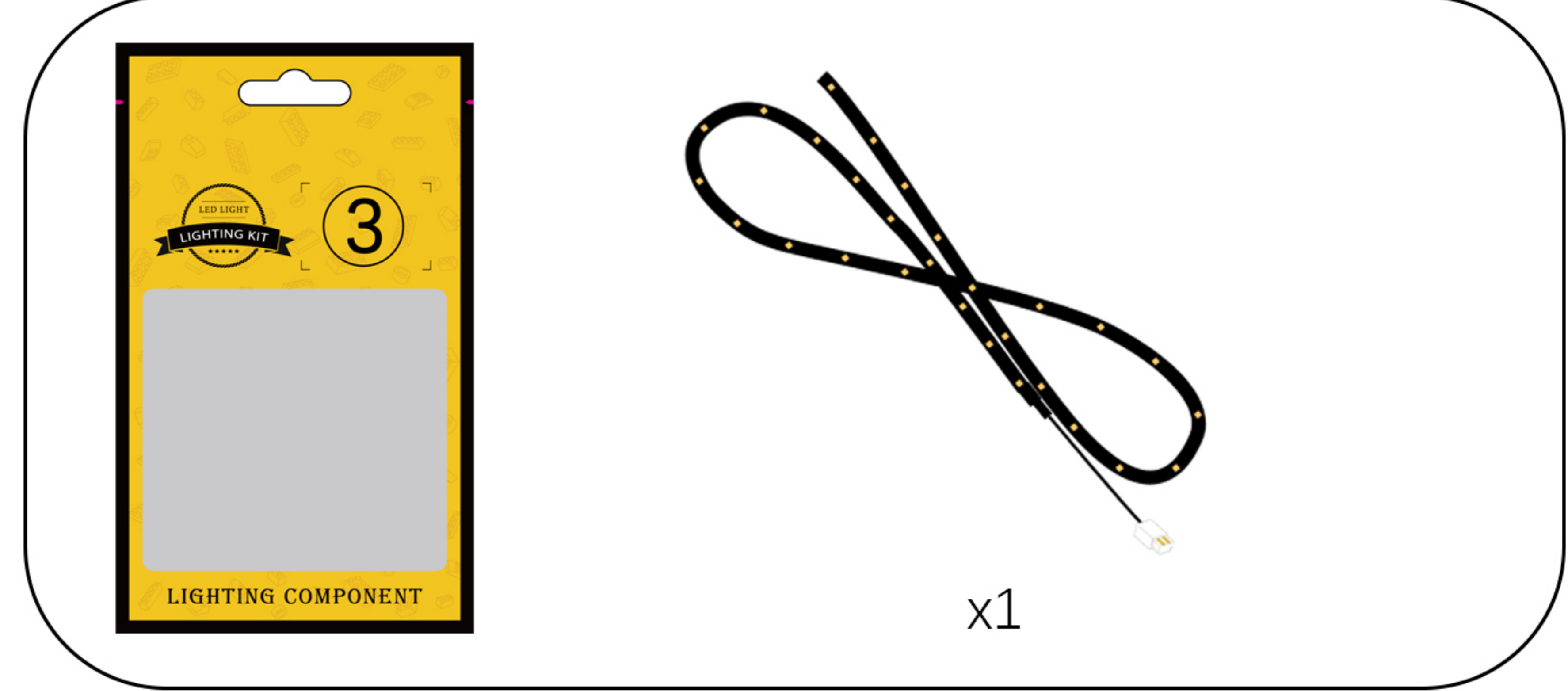

10

EN: Peel off the backing paper from the LED strip and attach it to the building block.

DE: Ziehen Sie das Trägerpapier vom LED-Streifen ab und befestigen Sie ihn am Baustein.

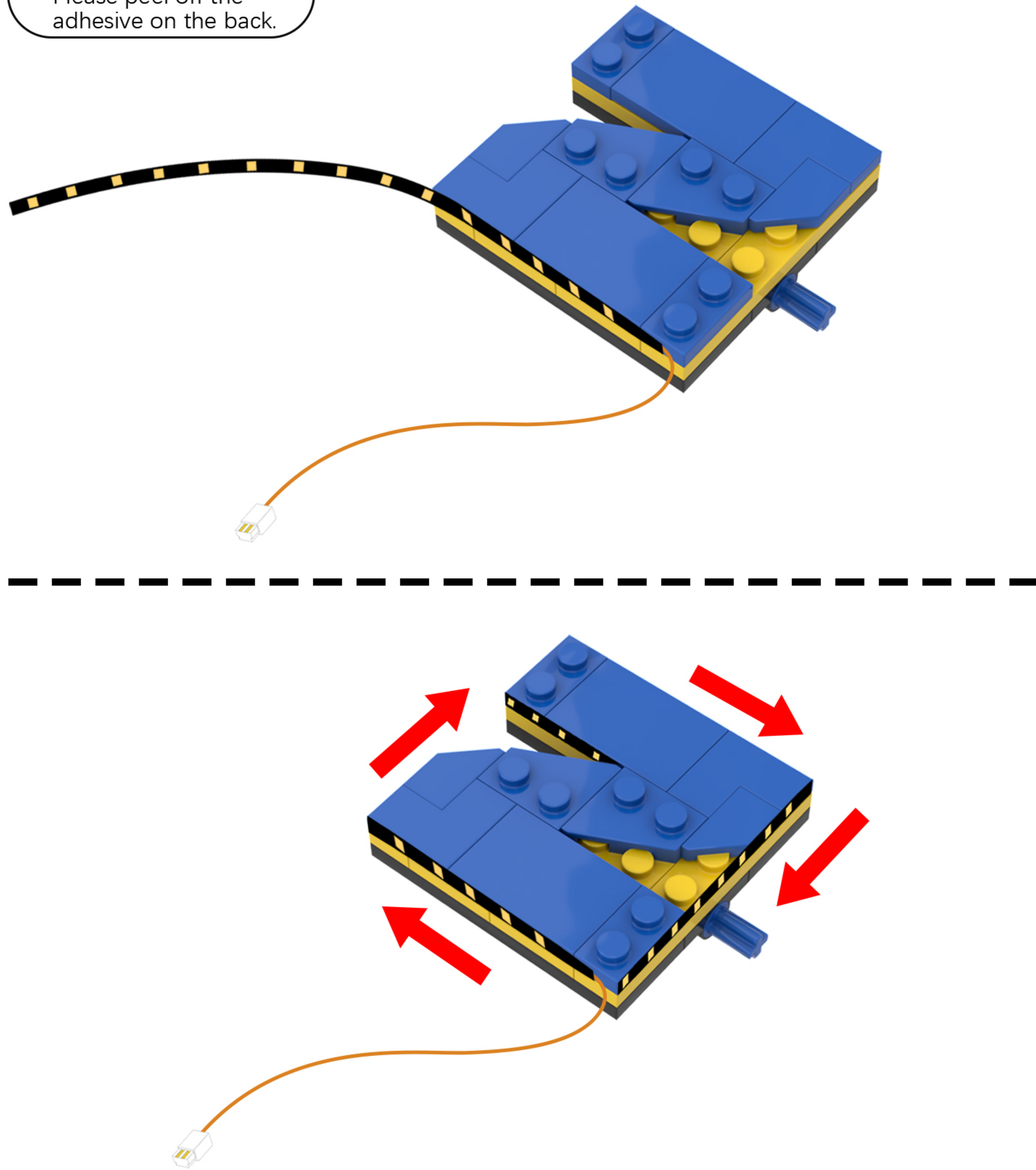

11

EN: Rotate the model to its back side.

DE: Drehen Sie das Modell auf die Rückseite.

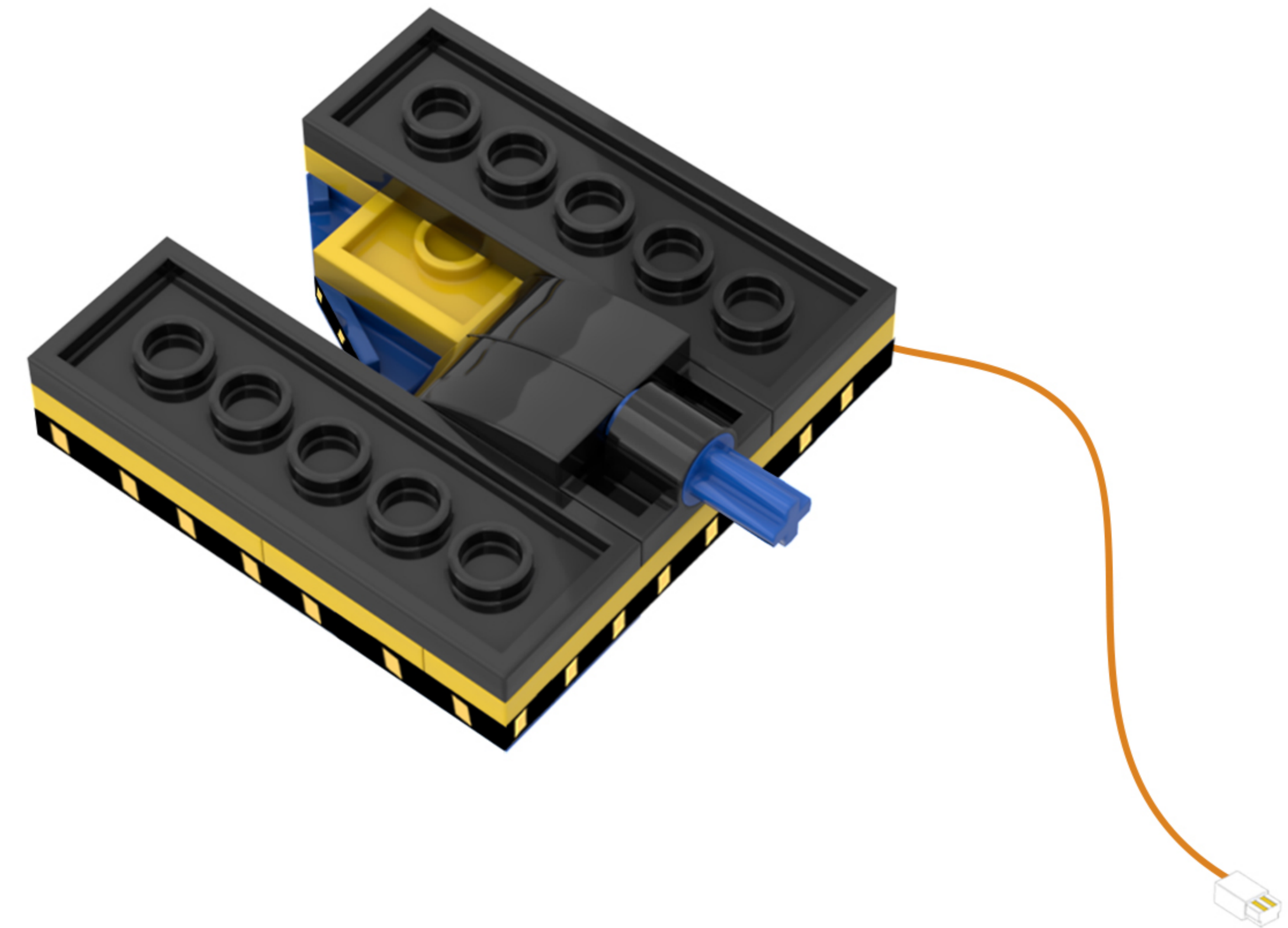

12

EN: Pull the building block out halfway.

DE: Zieh den Baustein zur Hälfte heraus.

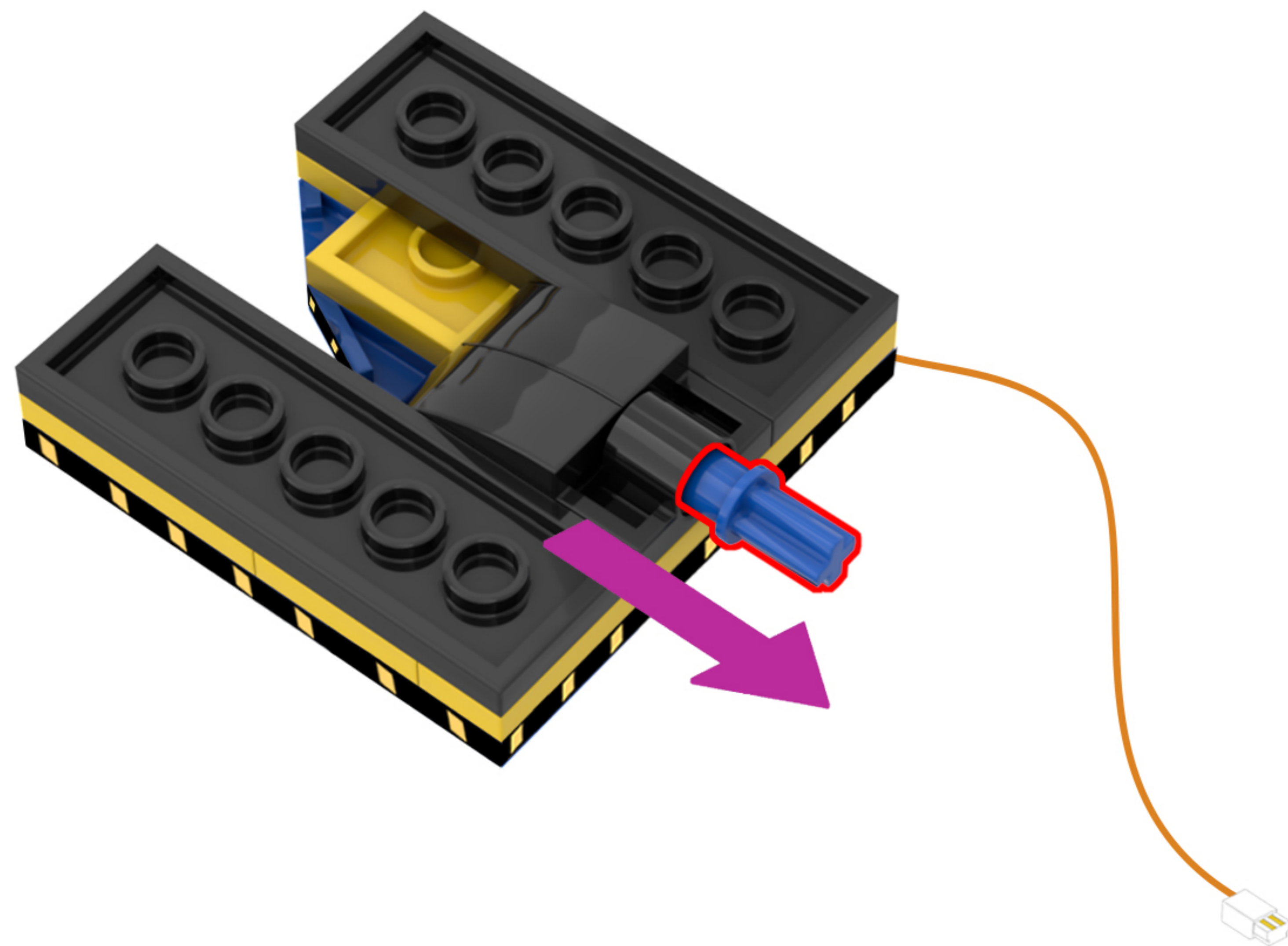

13

EN: Tuck part of the light cord into the gap in the building block.

DE: Stecken Sie einen Teil des Lampenkabels in den Spalt im Baustein.

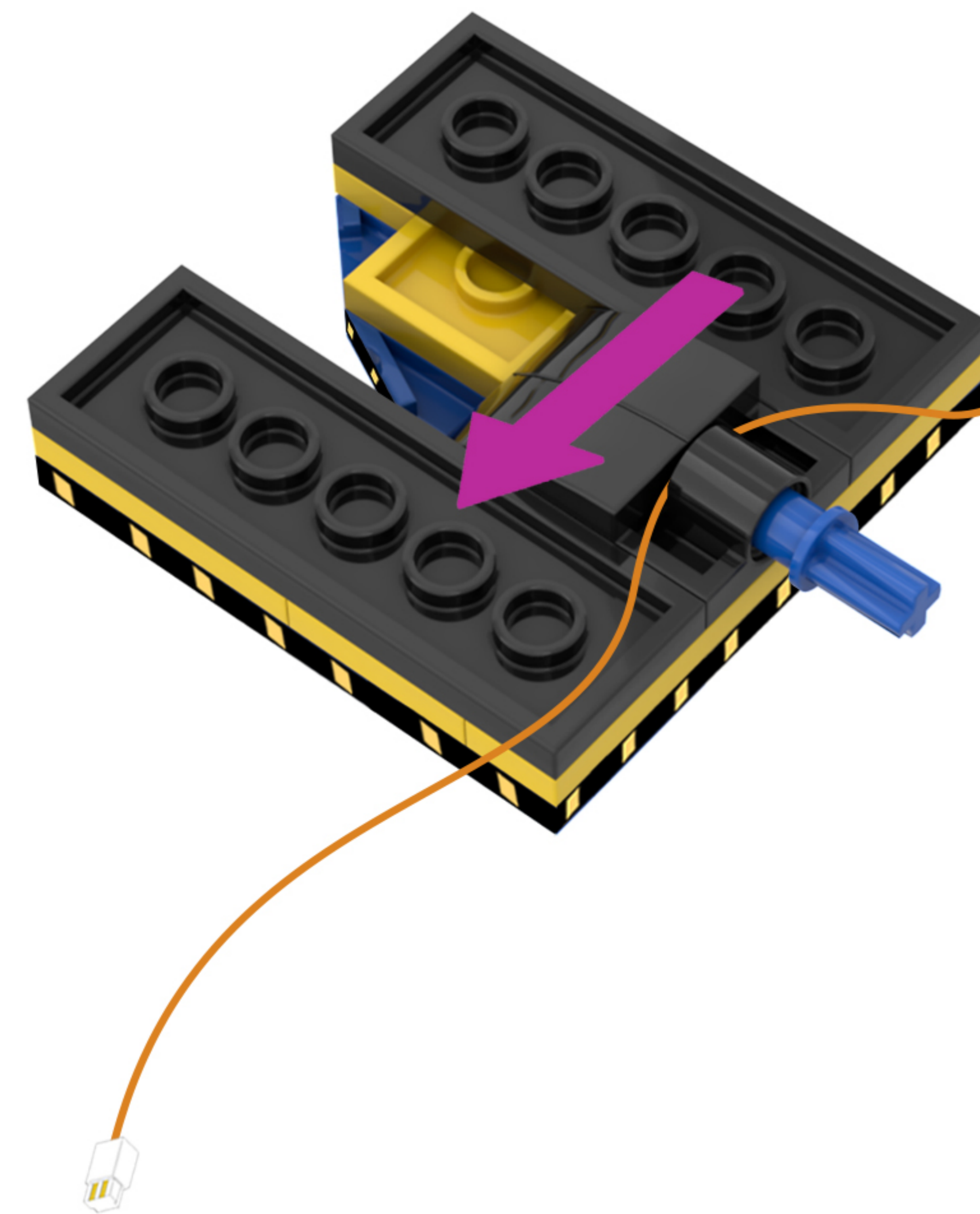

14

EN: Return the building blocks to their original positions so that they press down on the light cord.

DE: Bringen Sie die Bausteine wieder in ihre ursprüngliche Position, sodass sie auf das Lichtkabel drücken.

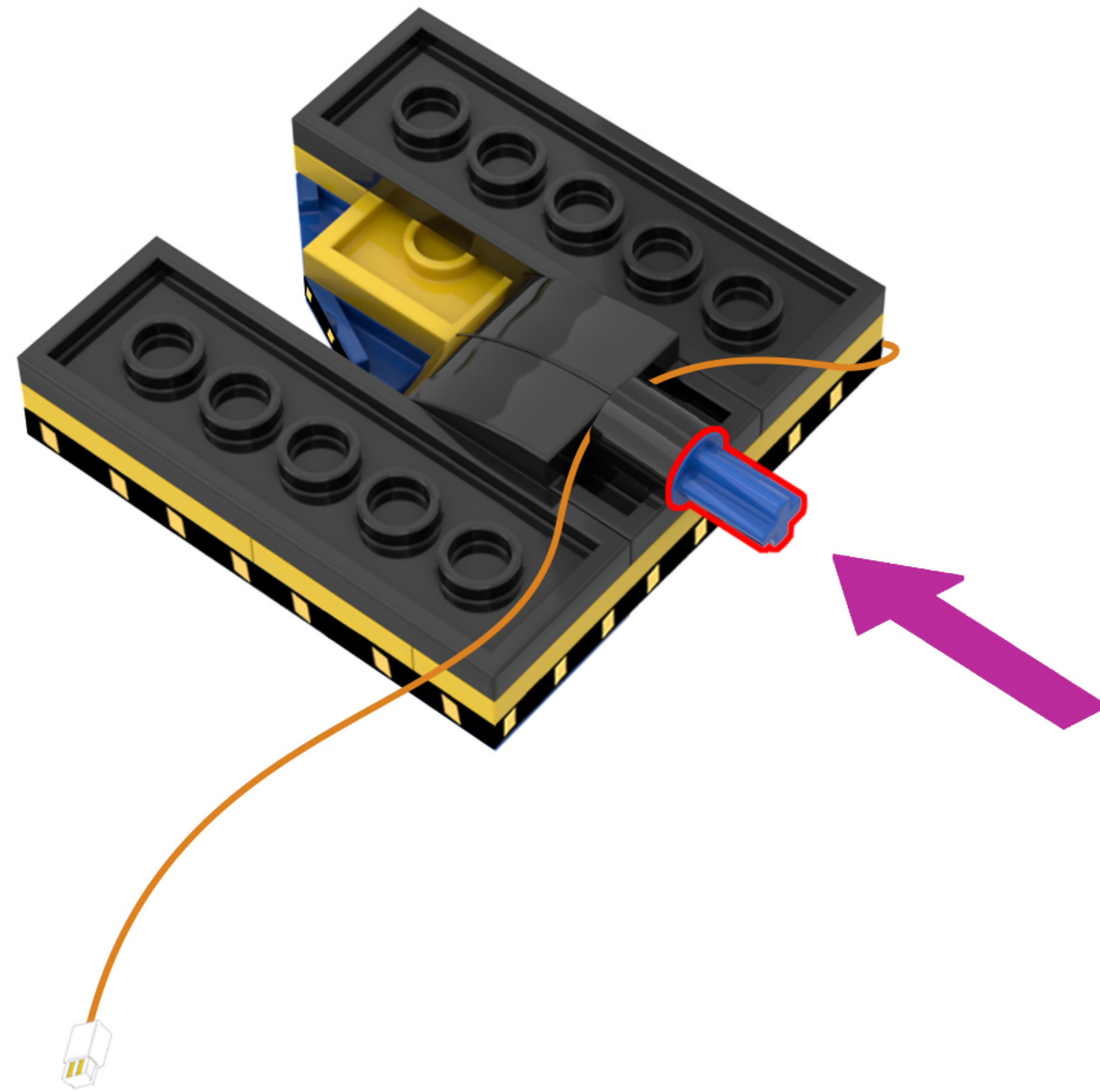

15

EN: Take the two light strips out of Bag 4, and remove the disassembled building blocks.

DE: Nimm die beiden Lichtleisten aus Beutel 4 heraus und entferne die zerlegten Bausteine.

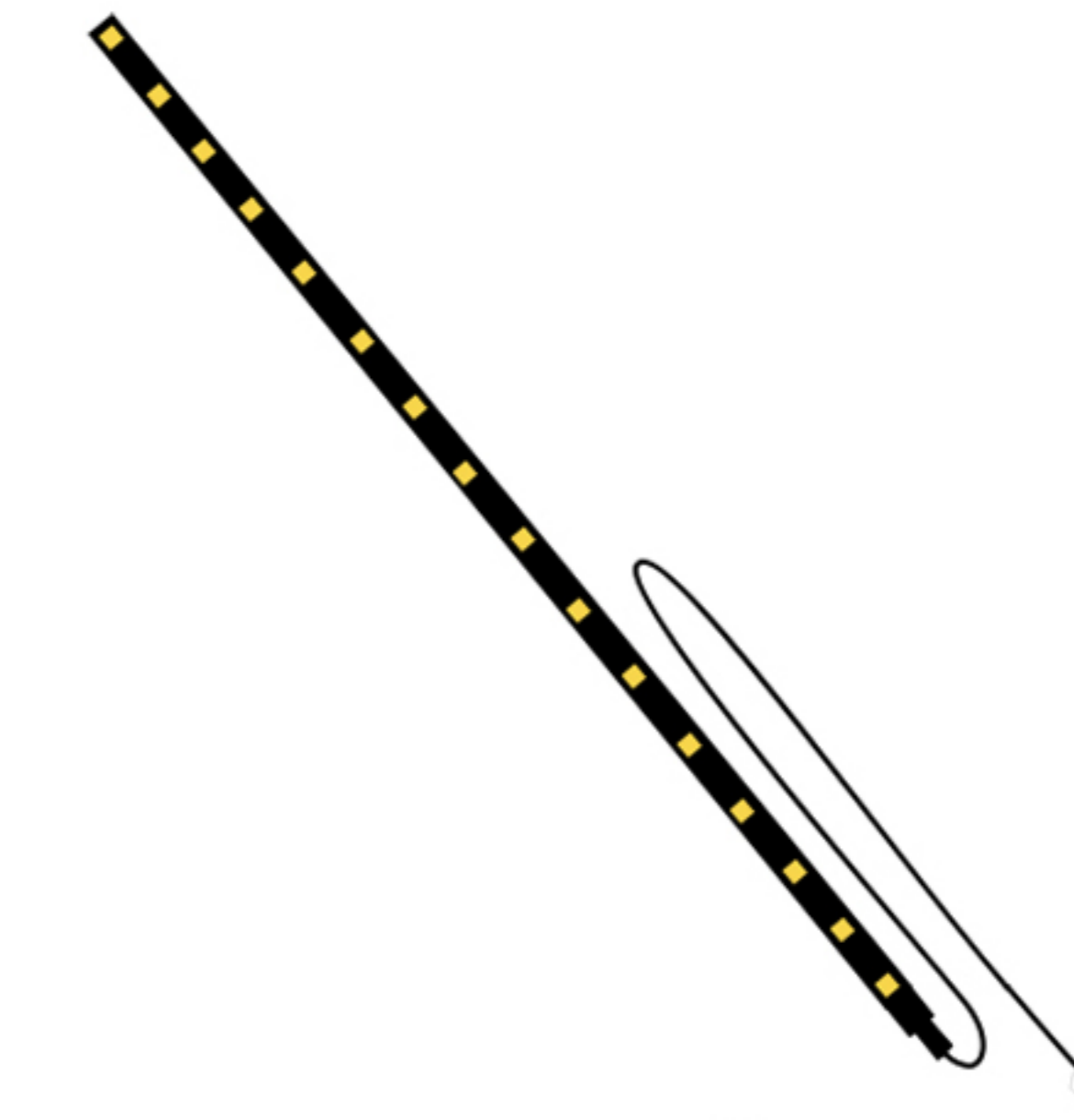
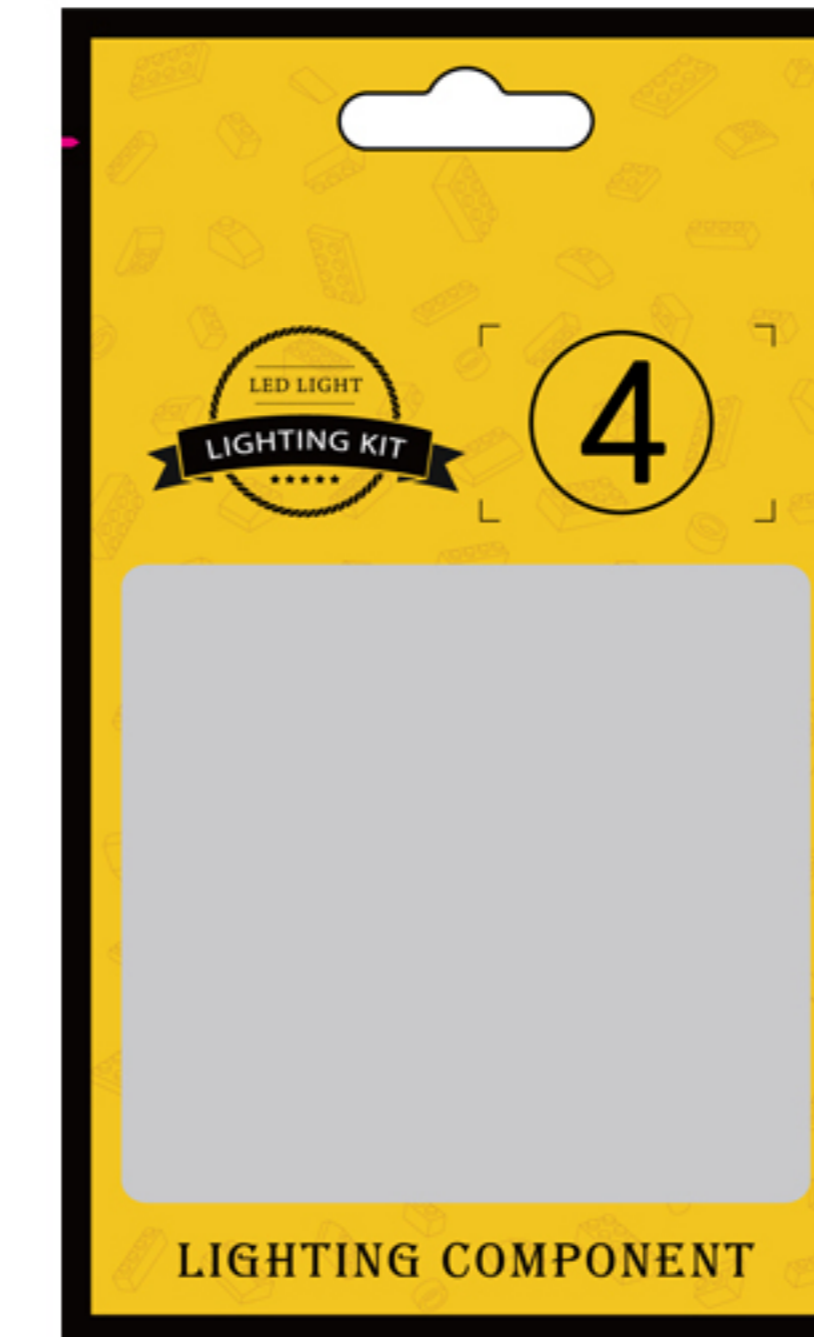

x2



x1

16

EN: Peel back the adhesive backing on one of the light strips and wrap it around the building block.

DE: Zieh die Schutzfolie von einem der Leuchtstreifen ab und wickle ihn um den Baustein.

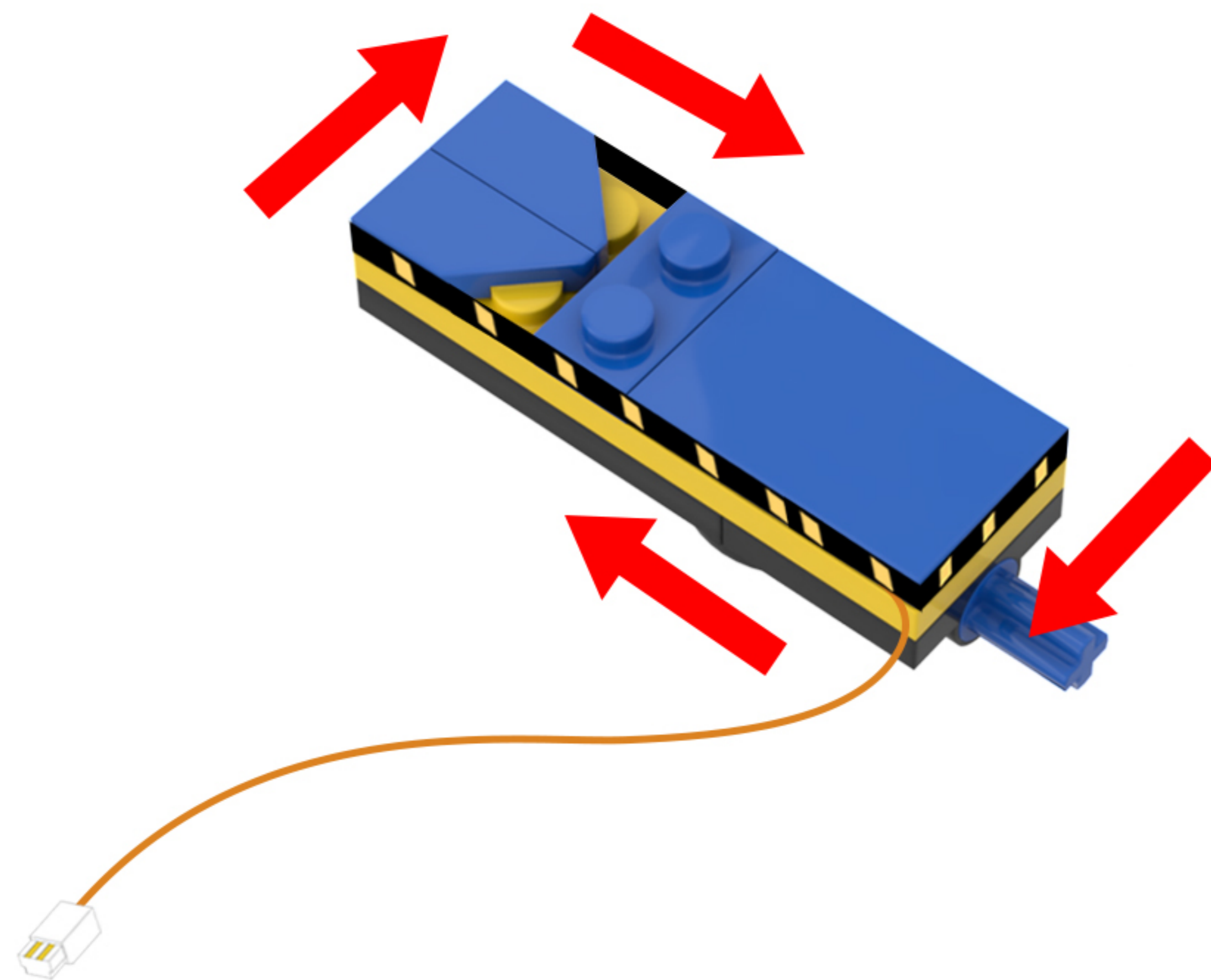
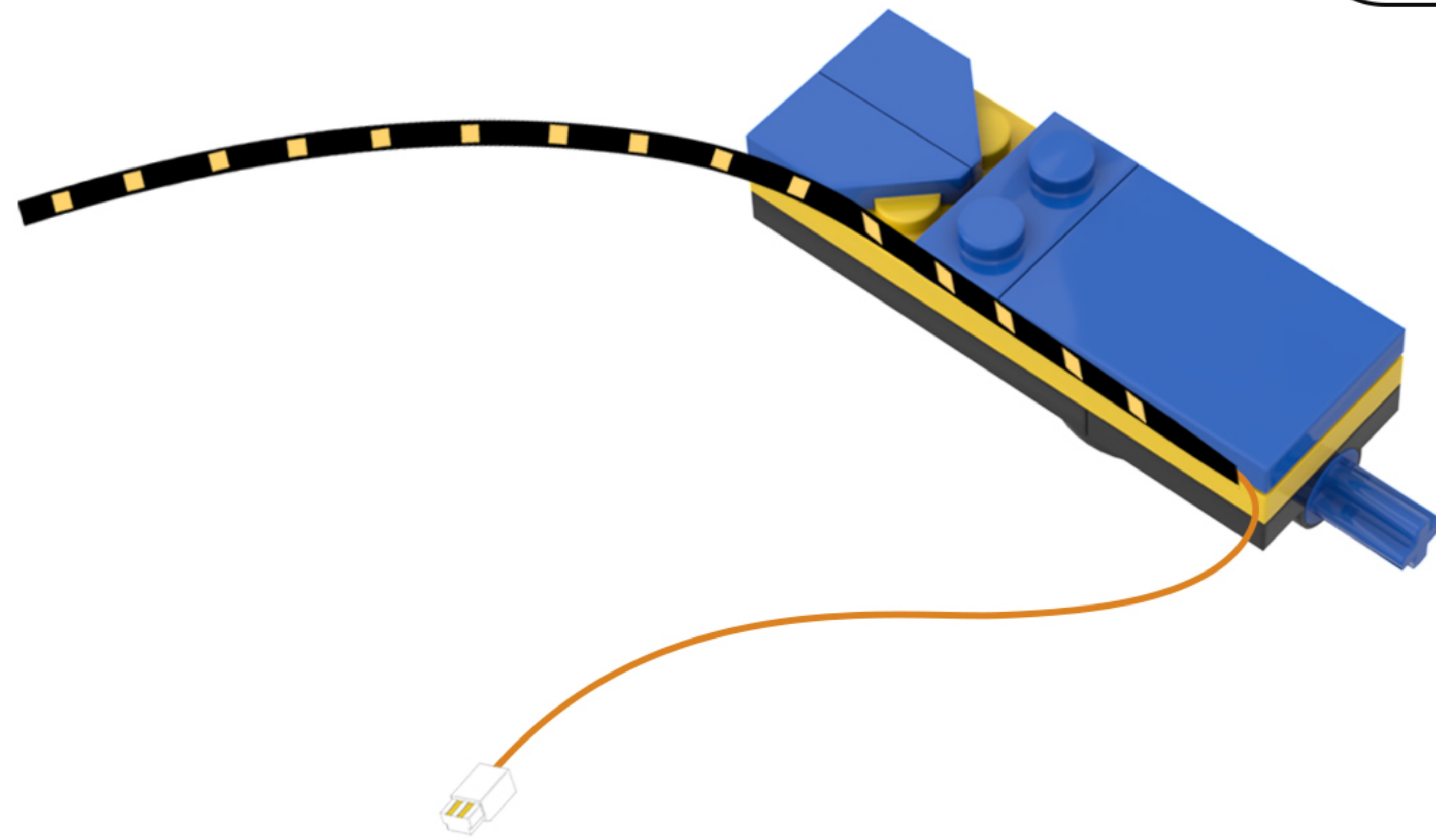
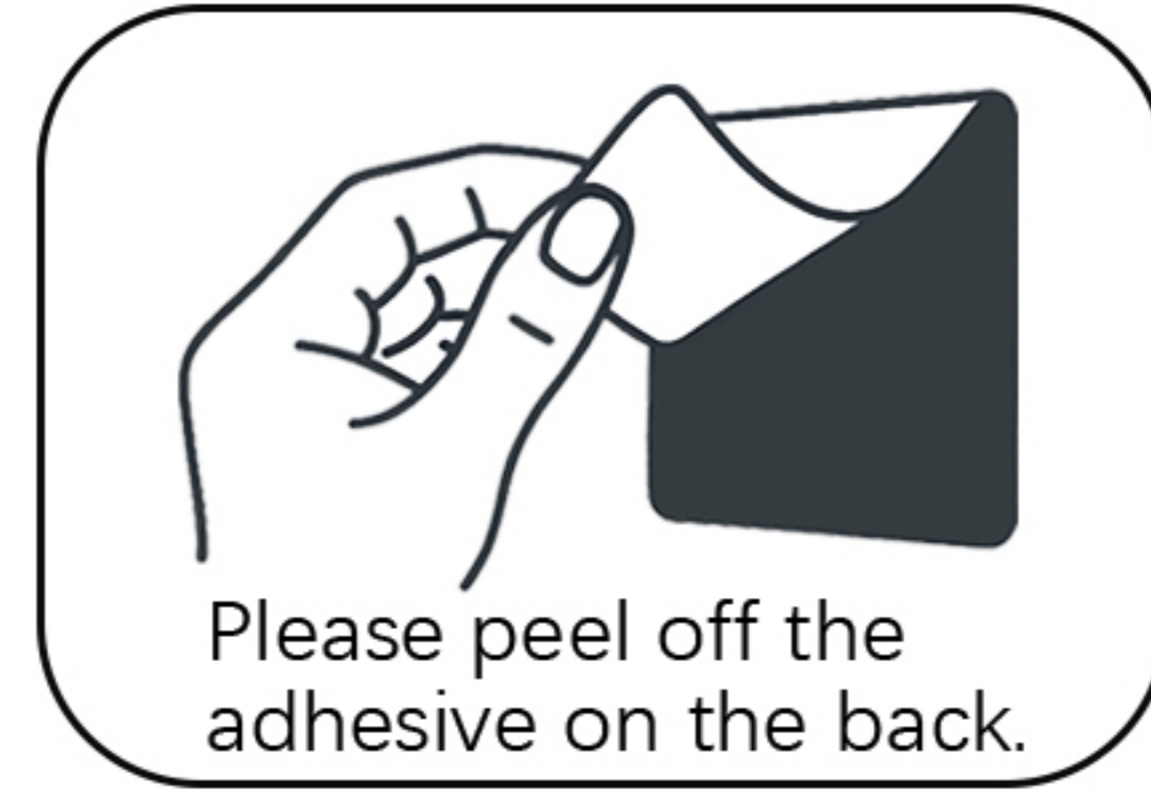

17

EN: Rotate the model to its back side.

DE: Drehen Sie das Modell auf die Rückseite.

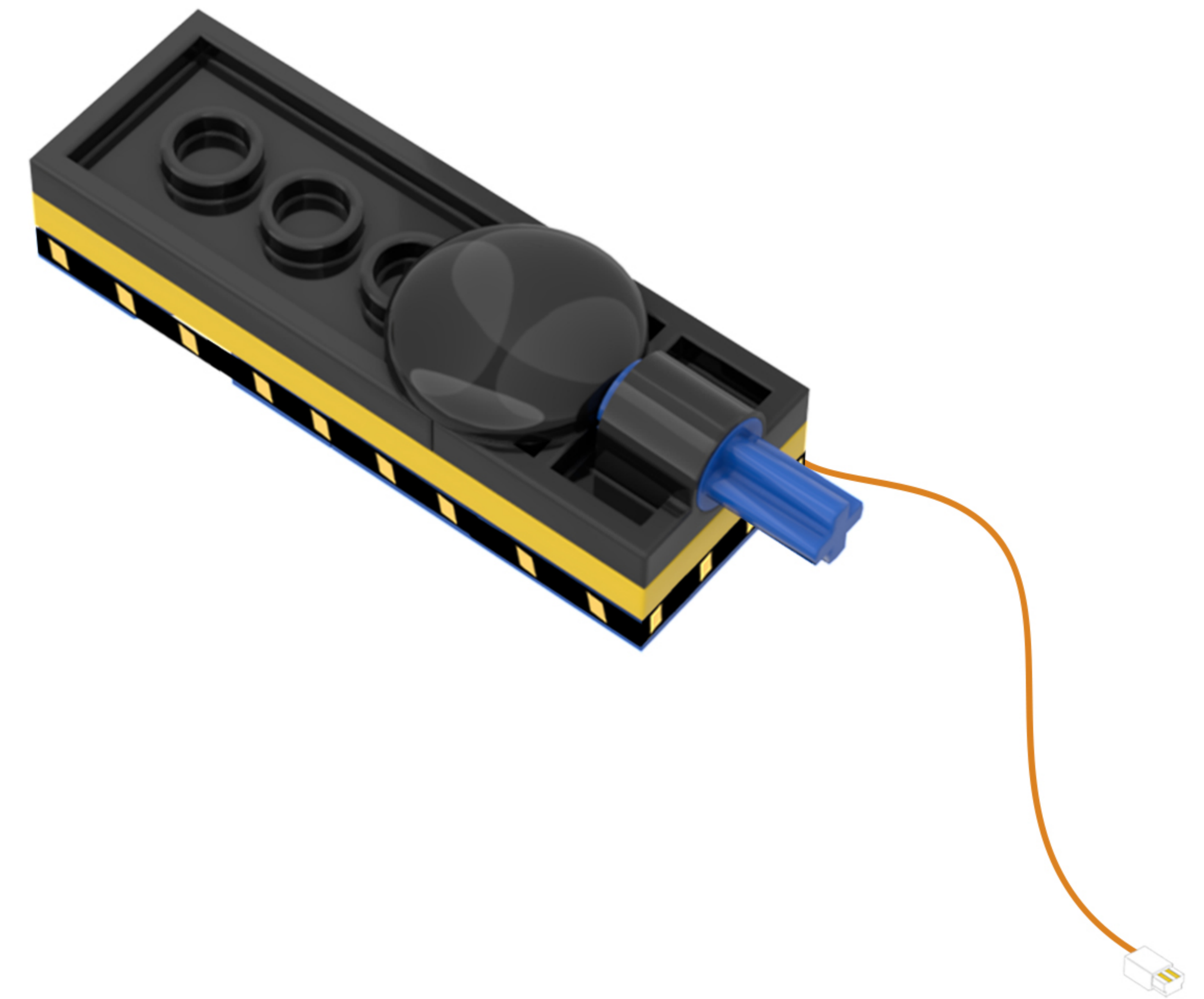

18

EN: Pull the building block out halfway.

DE: Zieh den Baustein zur Hälfte heraus.

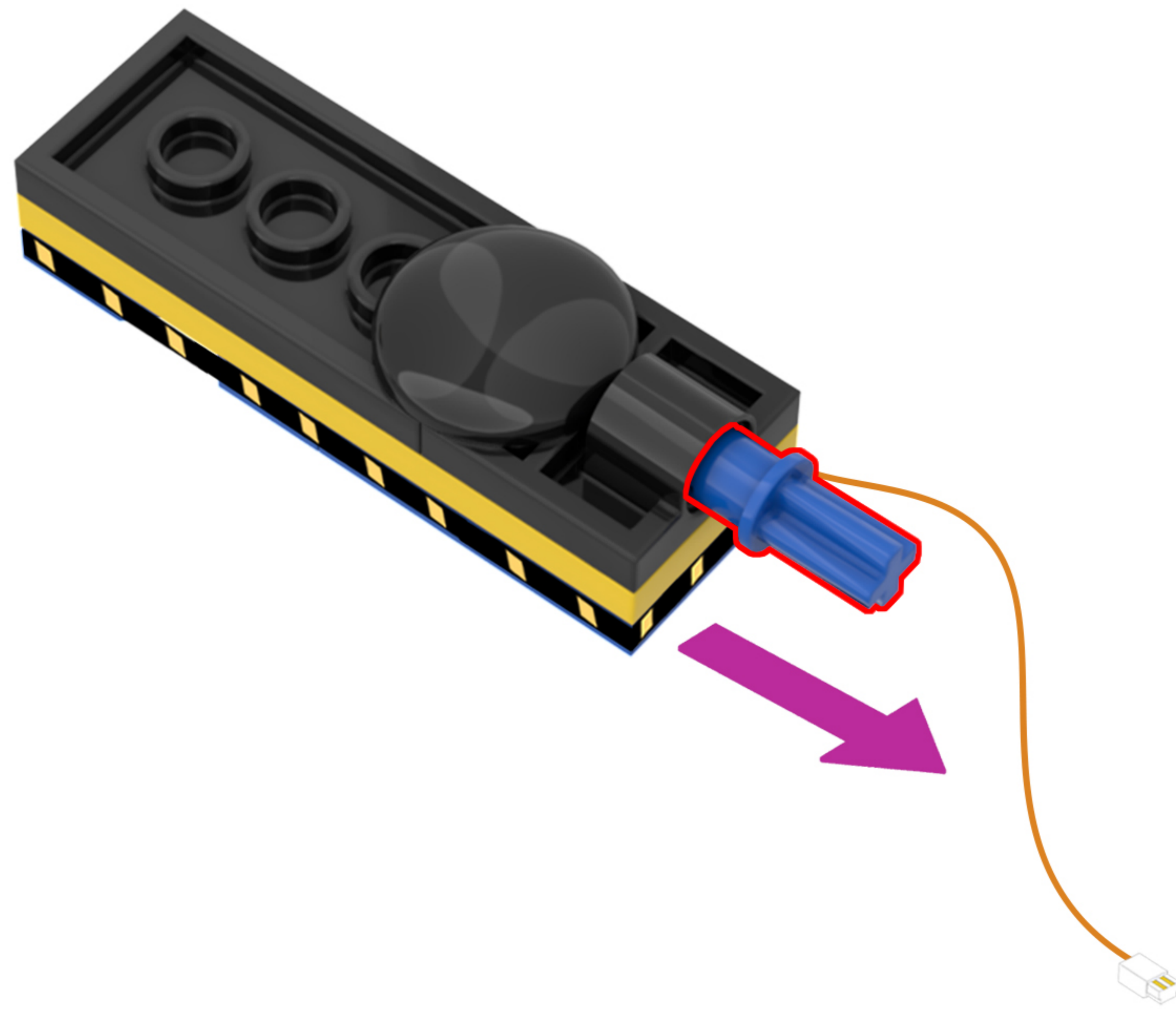

19

EN: Tuck part of the light cord into the gap in the building block.

DE: Stecken Sie einen Teil des Lampenkabels in den Spalt im Baustein.

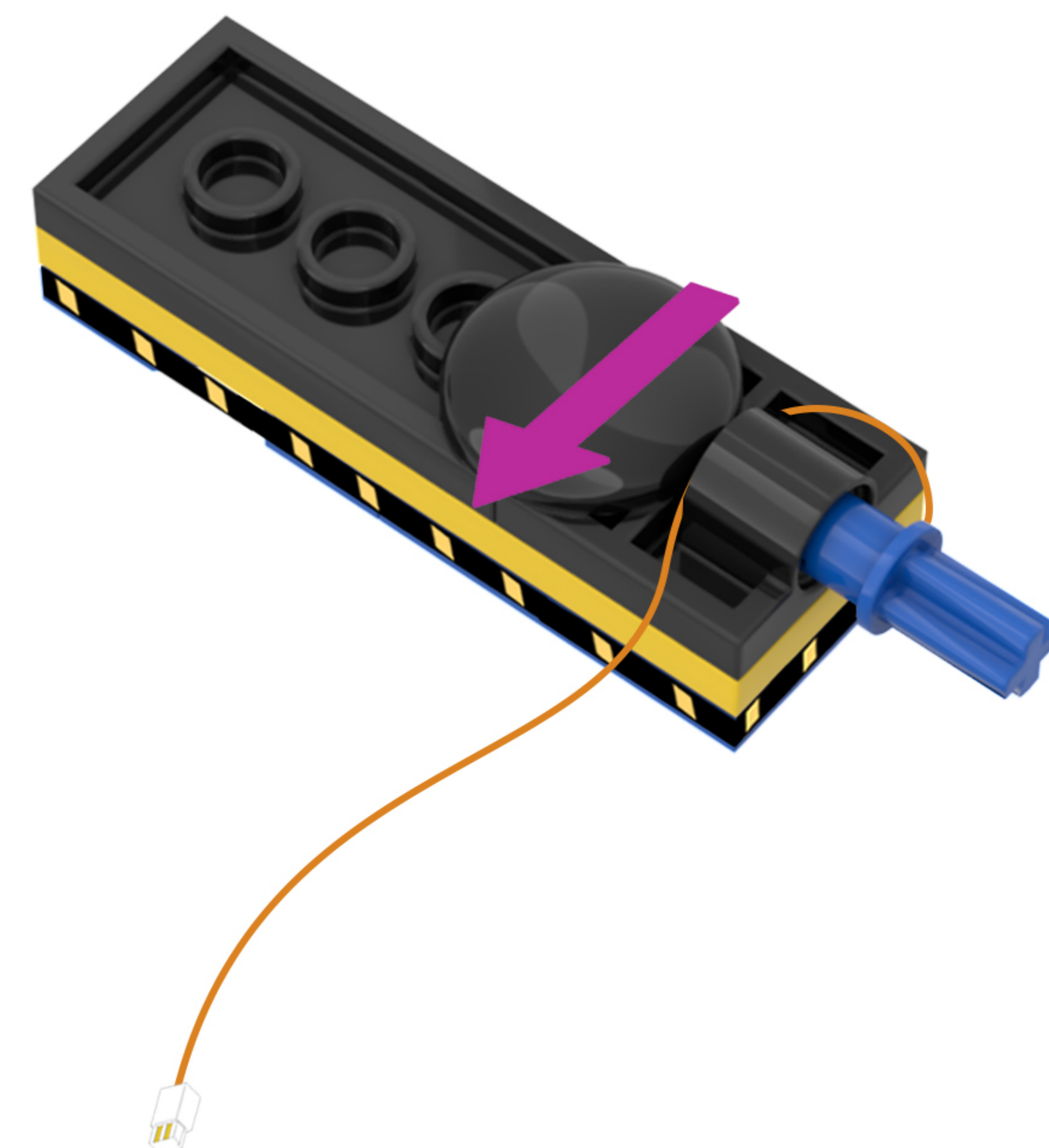

20

EN: Return the building blocks to their original positions so that they press down on the light cord.

DE: Bringen Sie die Bausteine wieder in ihre ursprüngliche Position, sodass sie auf das Lichtkabel drücken.

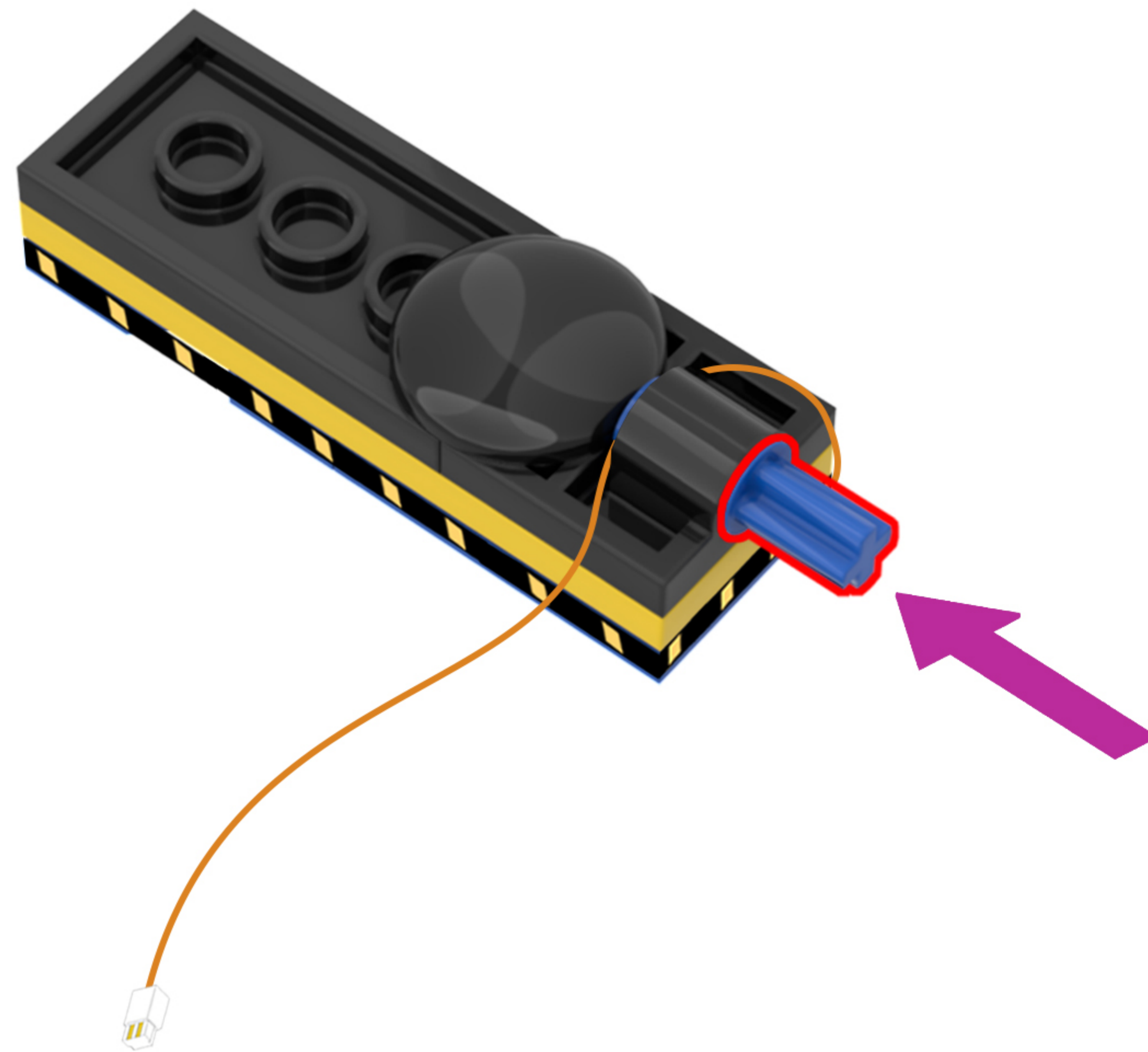

21

EN: Take out the disassembled building block piece, peel off the adhesive backing from the other LED strip, and attach it to the building block piece.

DE: Nehmen Sie das zerlegte Bausteinteil heraus, ziehen Sie die Schutzfolie vom anderen LED-Streifen ab und befestigen Sie ihn am Bausteinteil.

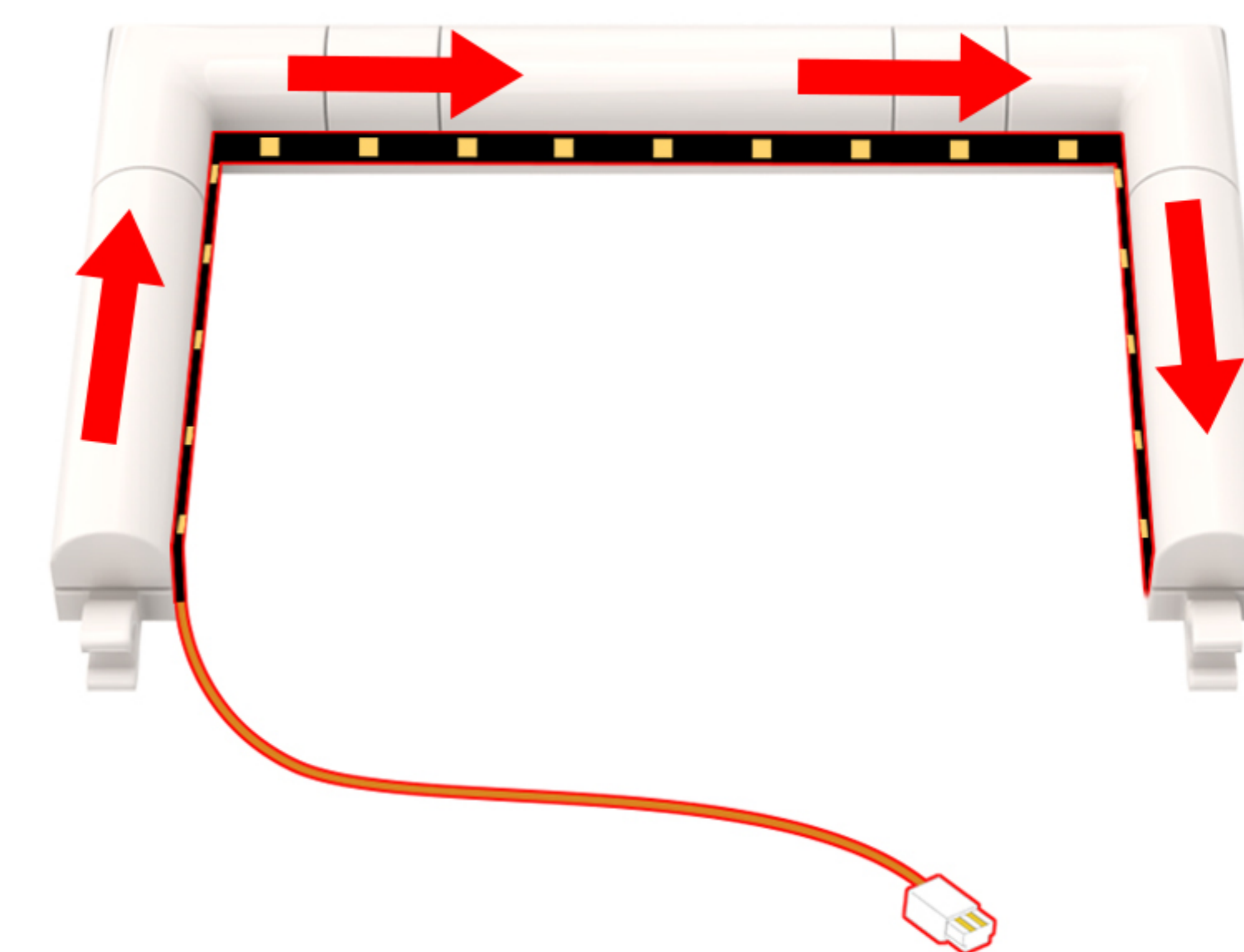
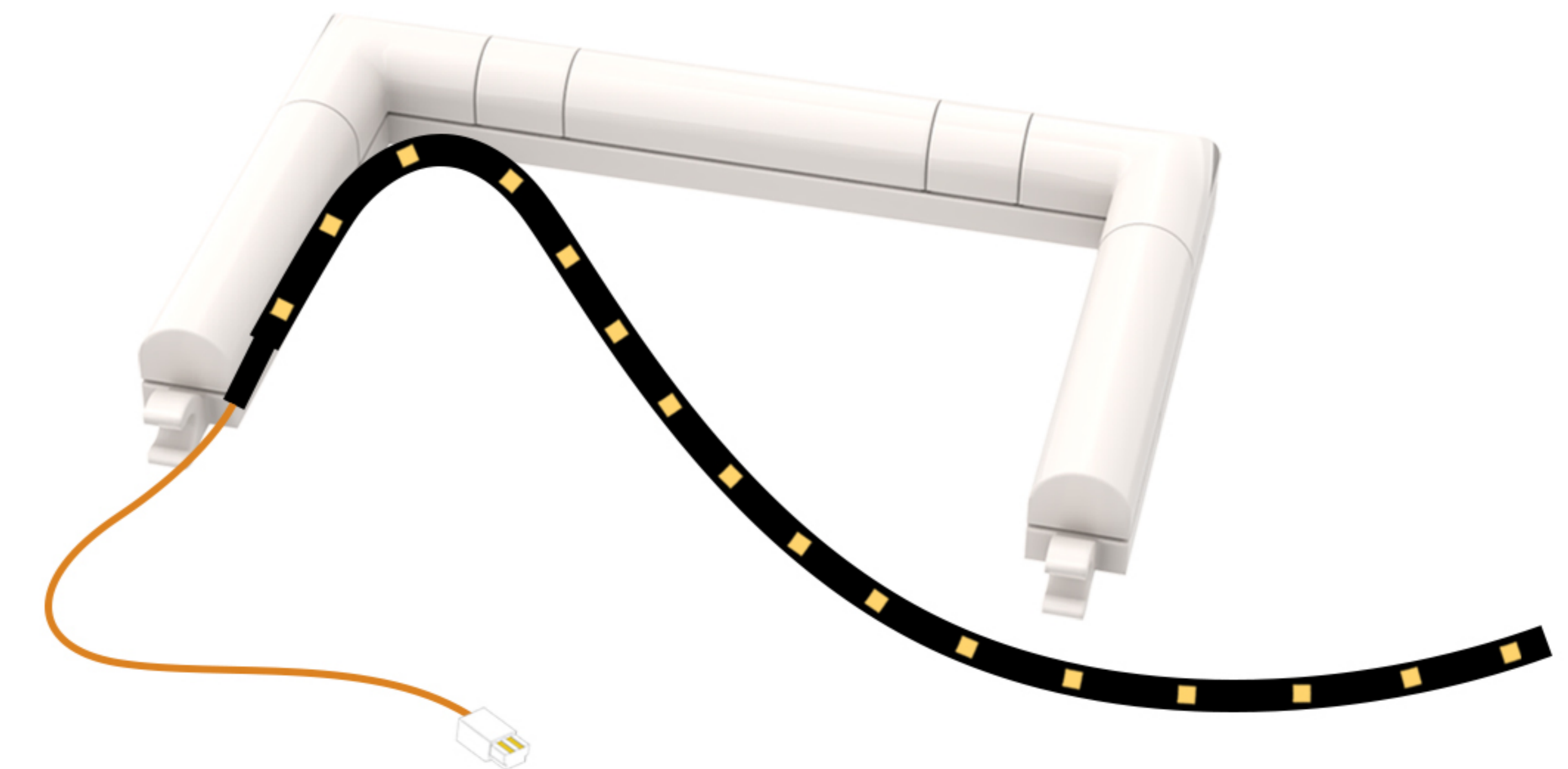
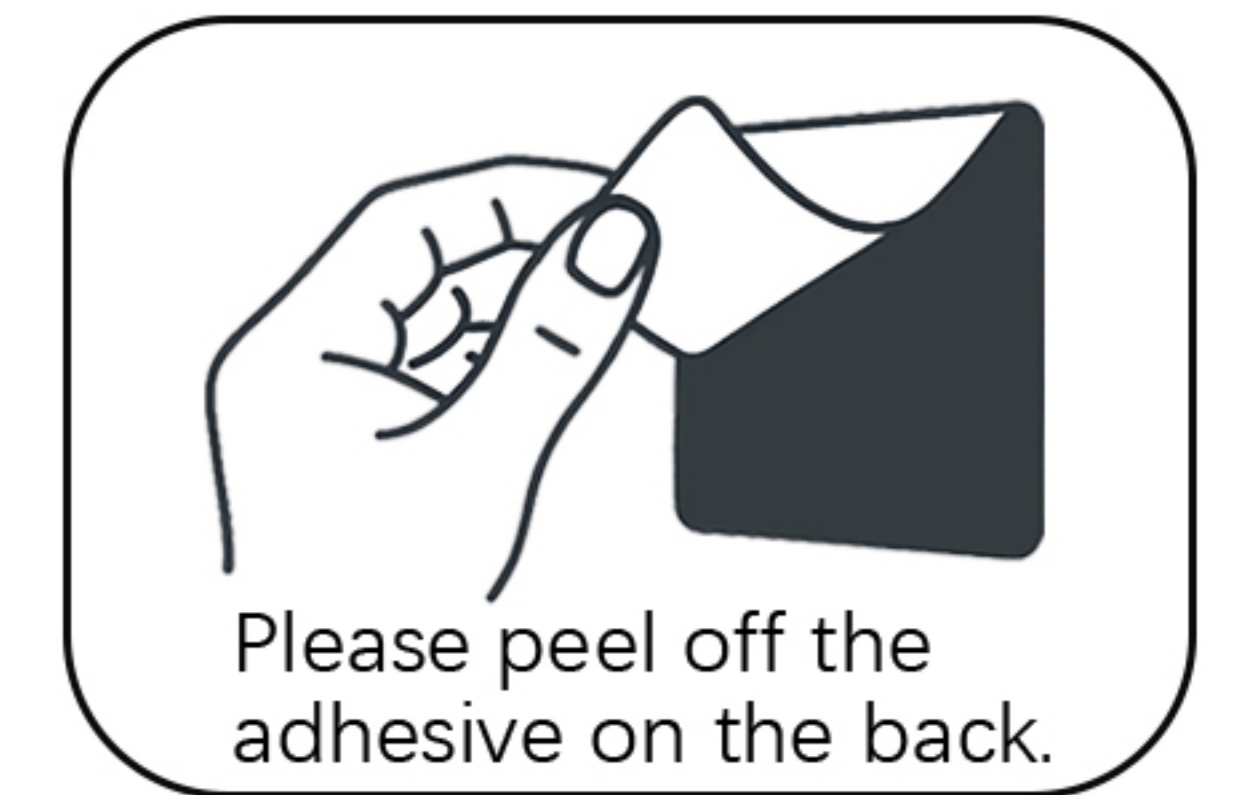
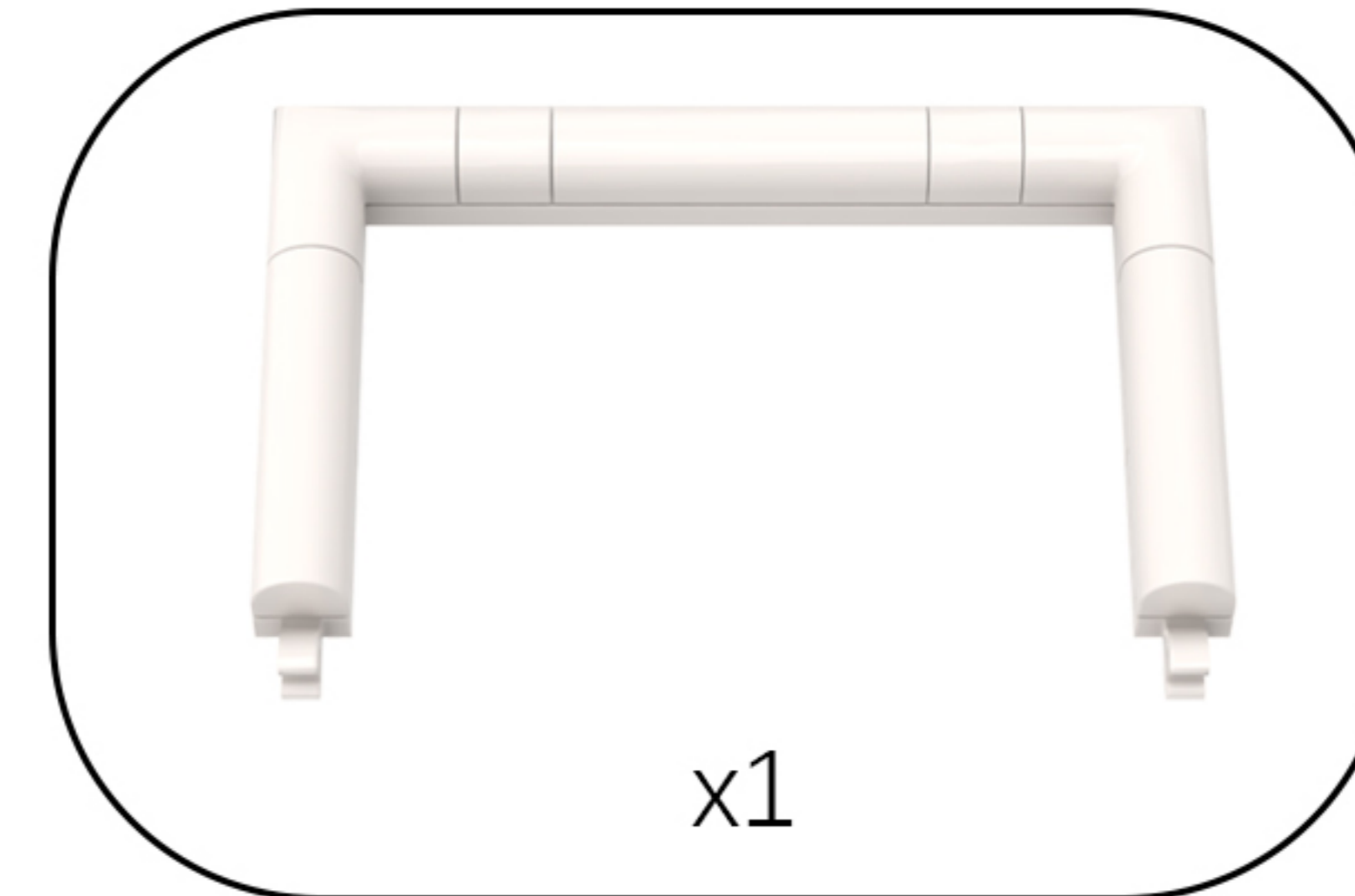

22

EN: Take the string lights out of Bag 5, along with the disassembled building blocks. Peel off the adhesive backing on the string lights and attach them to the locations shown in the diagram.

DE: Nimm die Lichterkette zusammen mit den zerlegten Bausteinen aus Beutel 5 heraus. Ziehe die Schutzfolie von der Lichterkette ab und befestige sie an den in der Abbildung gezeigten Stellen.

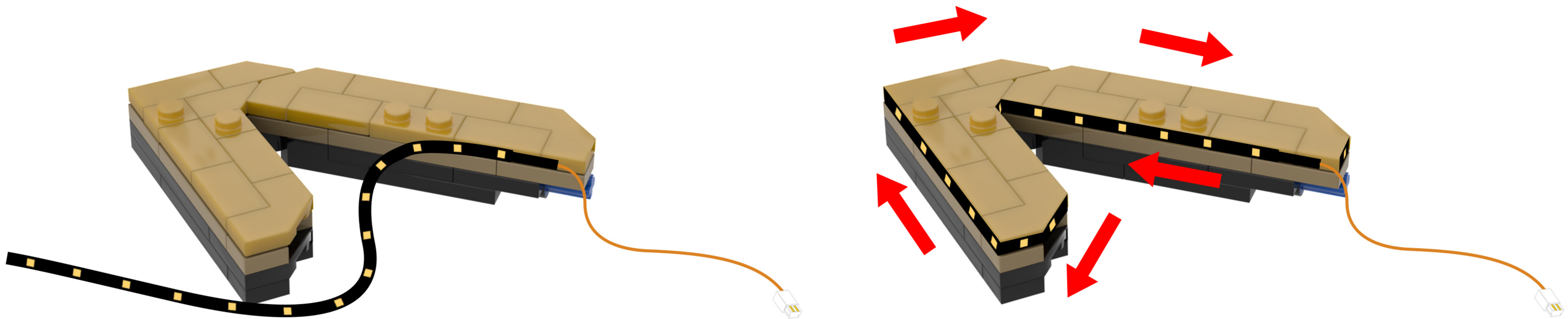
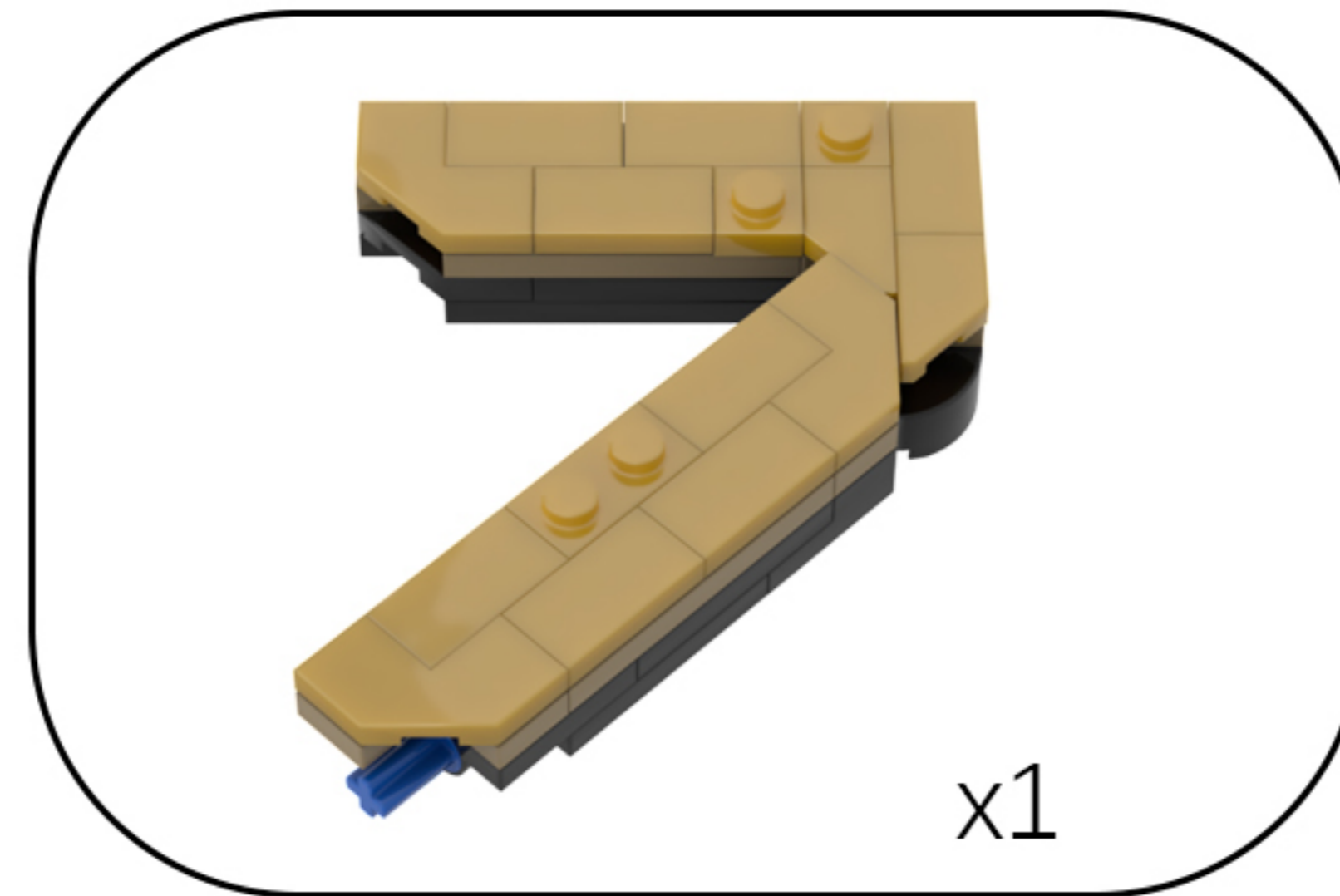
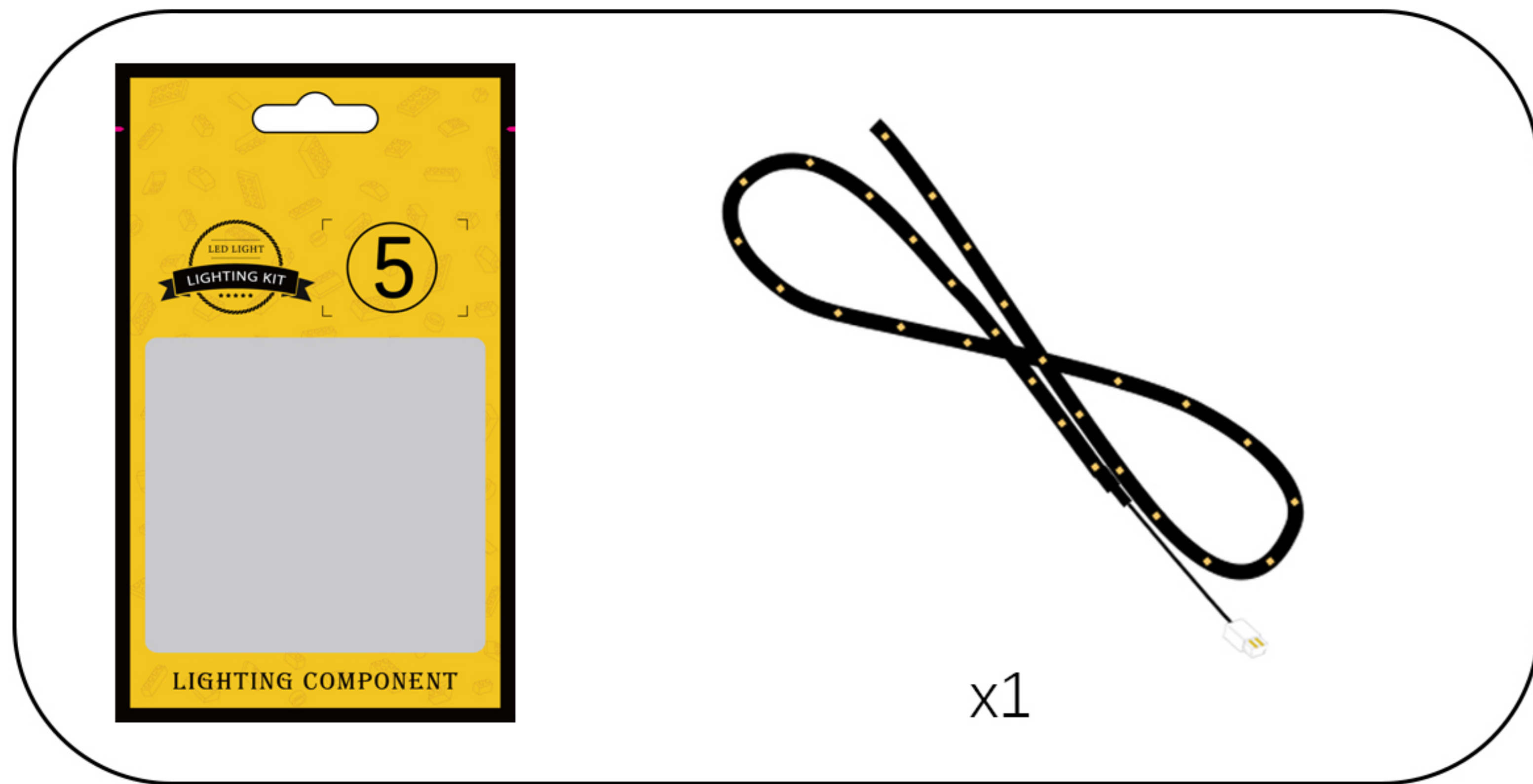

23

EN: Rotate the model to its back side.

DE: Drehen Sie das Modell auf die Rückseite.

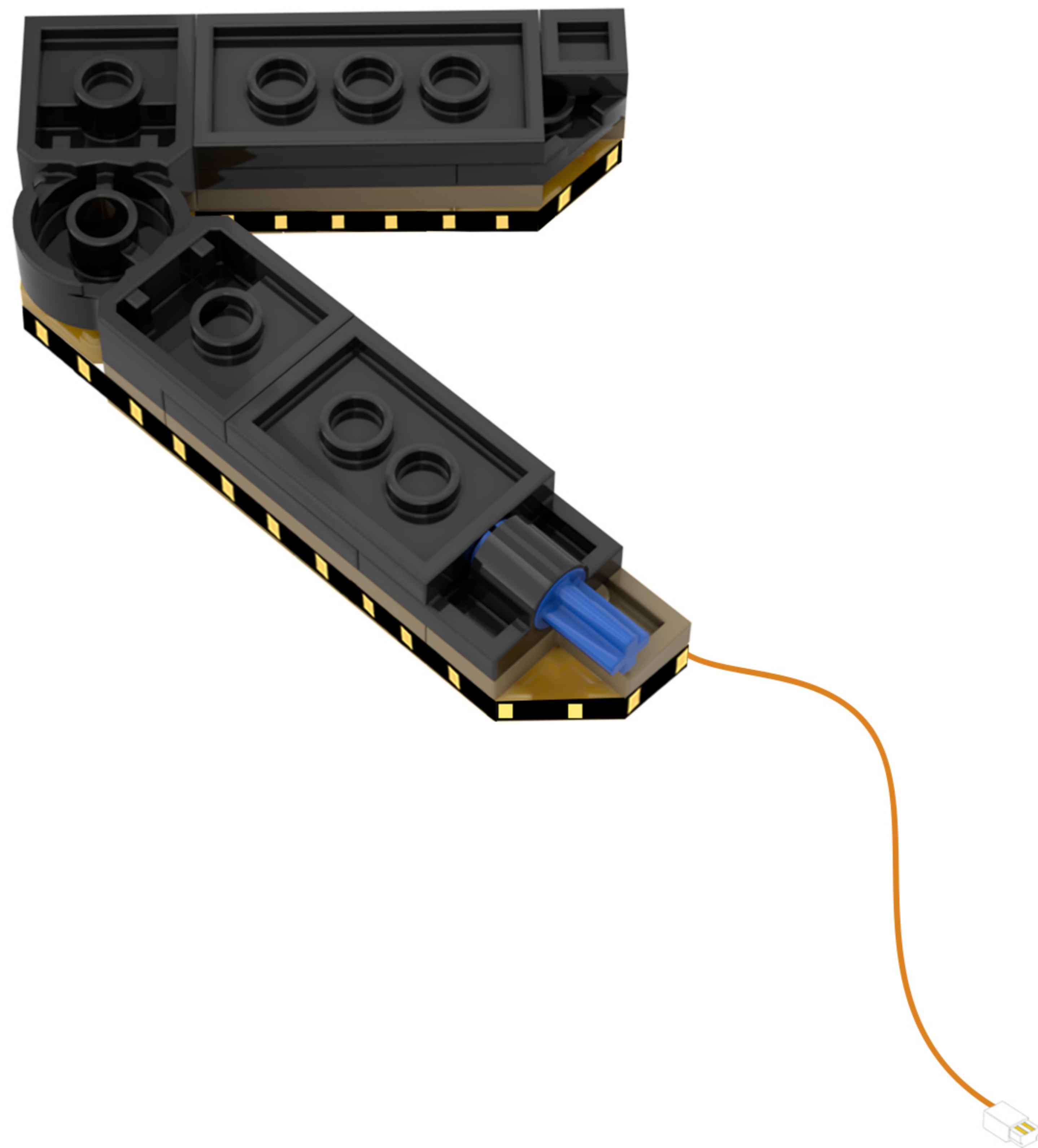
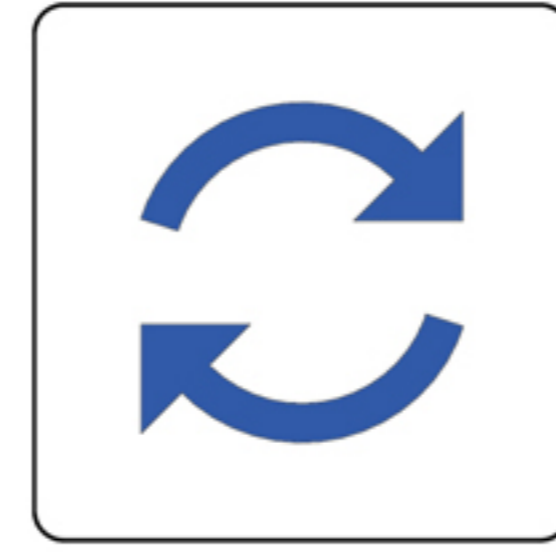

24

EN: Pull the building block out halfway.

DE: Zieh den Baustein zur Hälfte heraus.

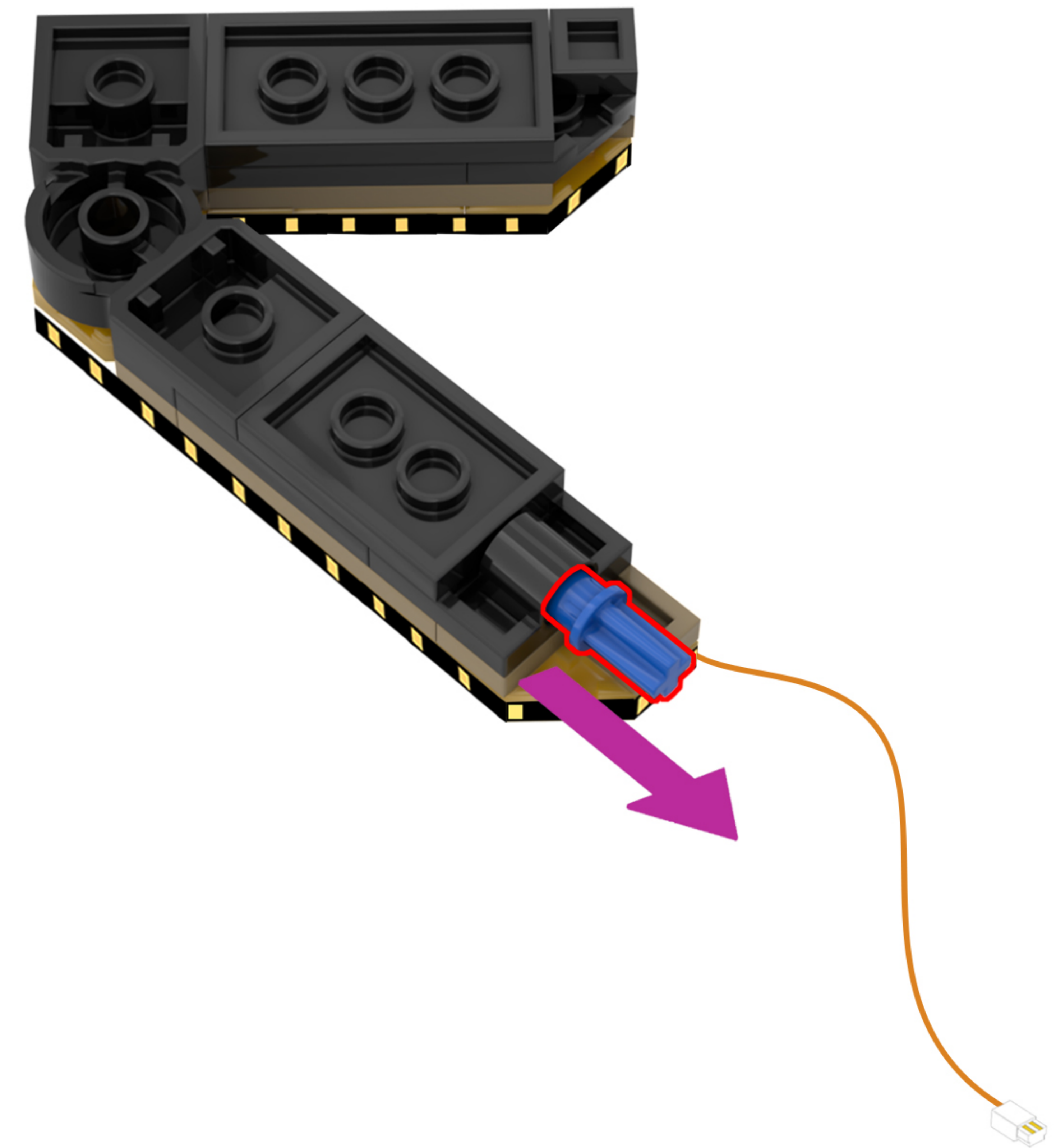

25

EN: Tuck part of the light cord into the gap in the building block.

DE: Stecken Sie einen Teil des Lampenkabels in den Spalt im Baustein.

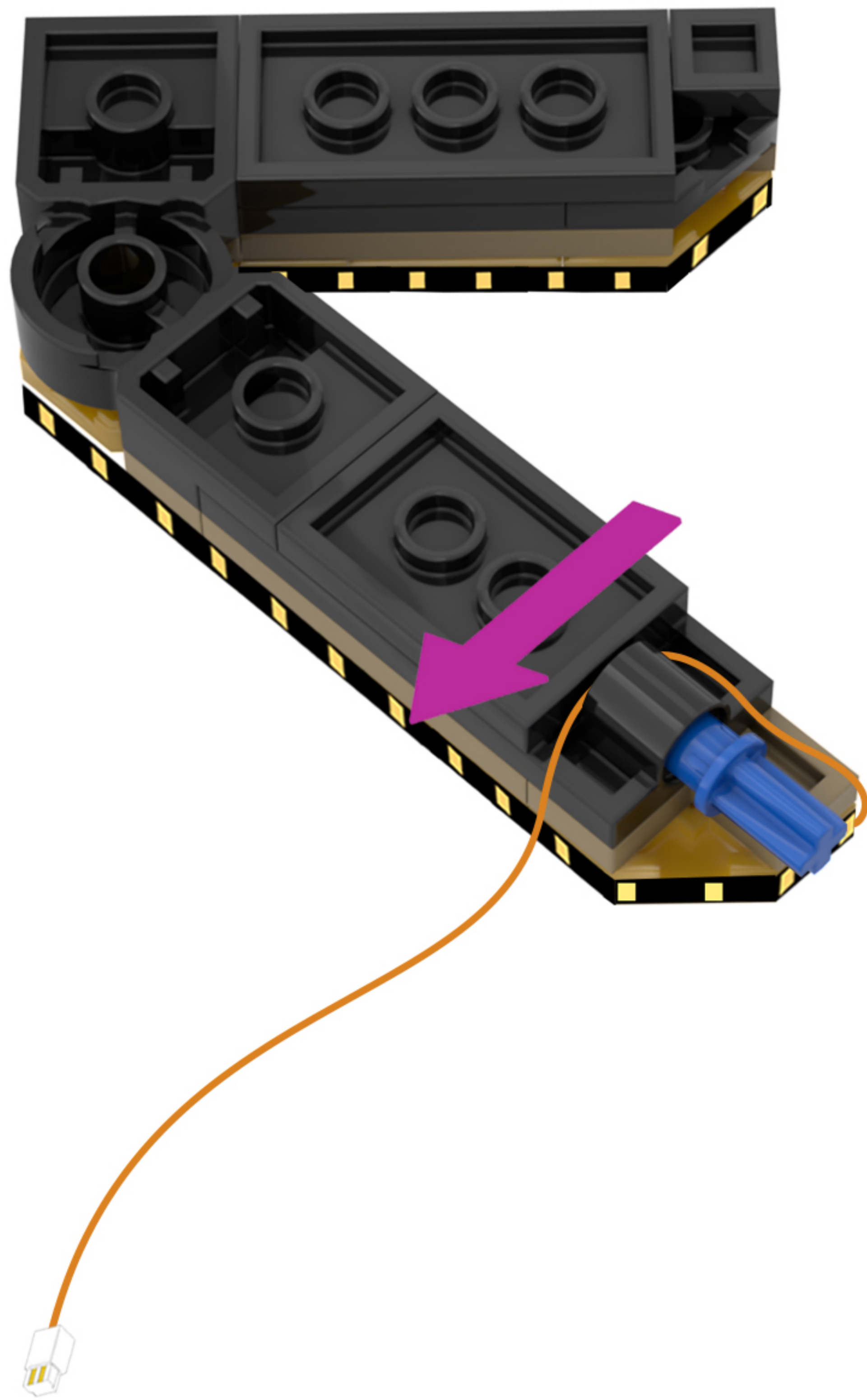

26

EN: Return the building blocks to their original positions so that they press down on the light cord.

DE: Bringen Sie die Bausteine wieder in ihre ursprüngliche Position, sodass sie auf das Lichtkabel drücken.

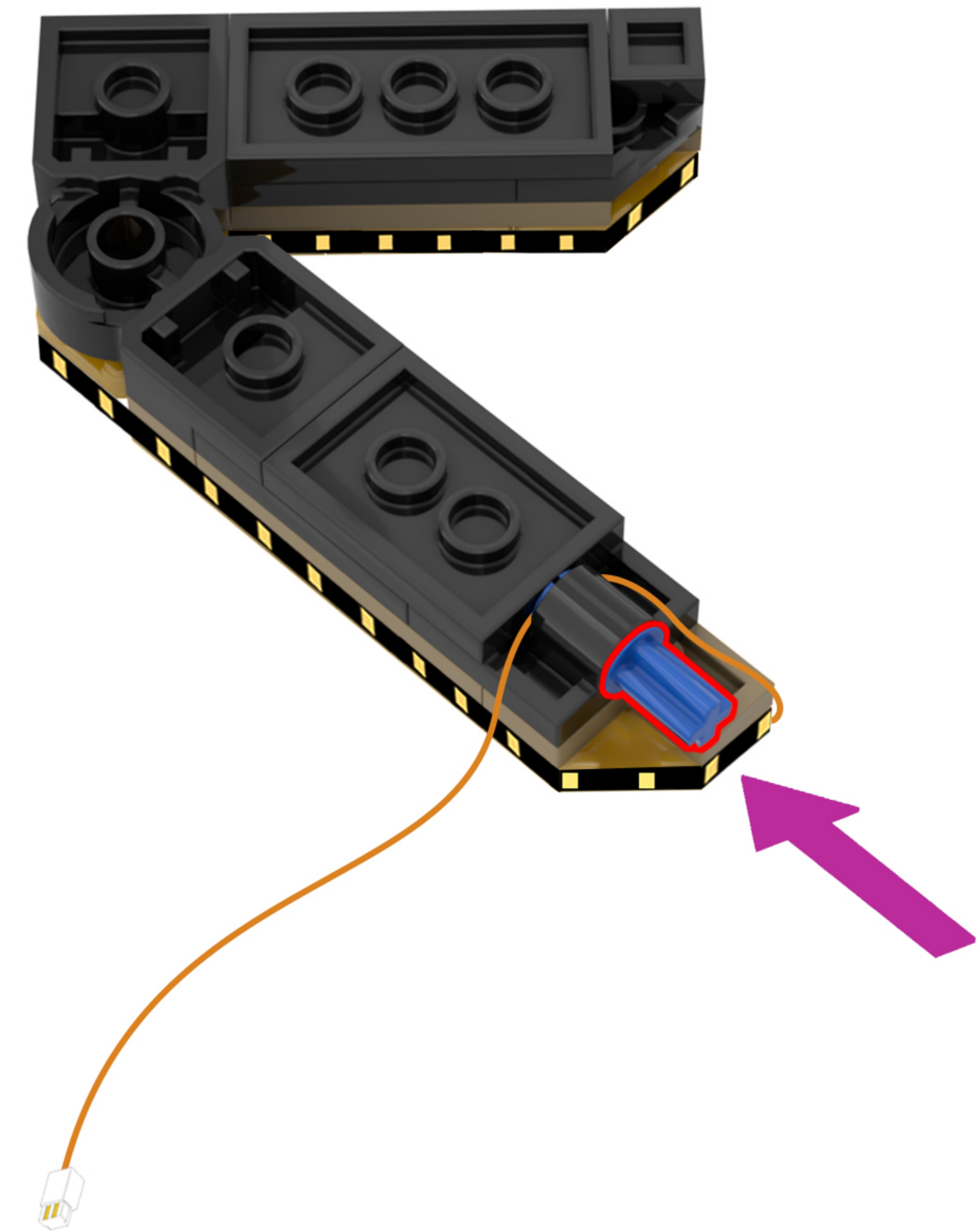

27

EN: Back to the model.

DE: Zurück zum Modell.



28

EN: Split as shown in the figure.

DE: Wie in der Abbildung gezeigt, teilen Sie es auf.



29

EN: Rotate the model to the side.

DE: Drehen Sie das Modell zur Seite.

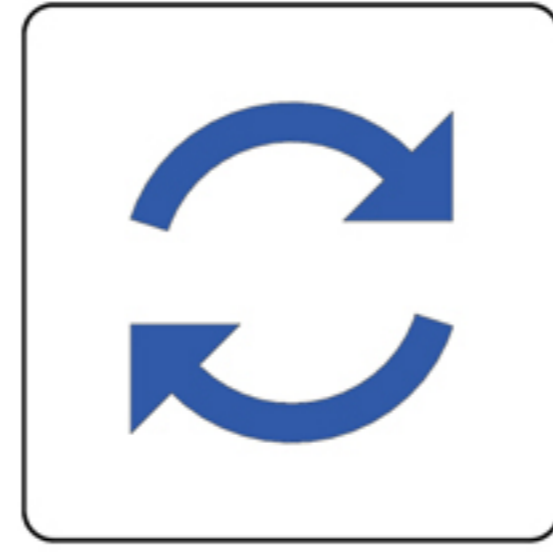

30

EN: Split as shown in the figure.

DE: Wie in der Abbildung gezeigt, teilen Sie es auf.

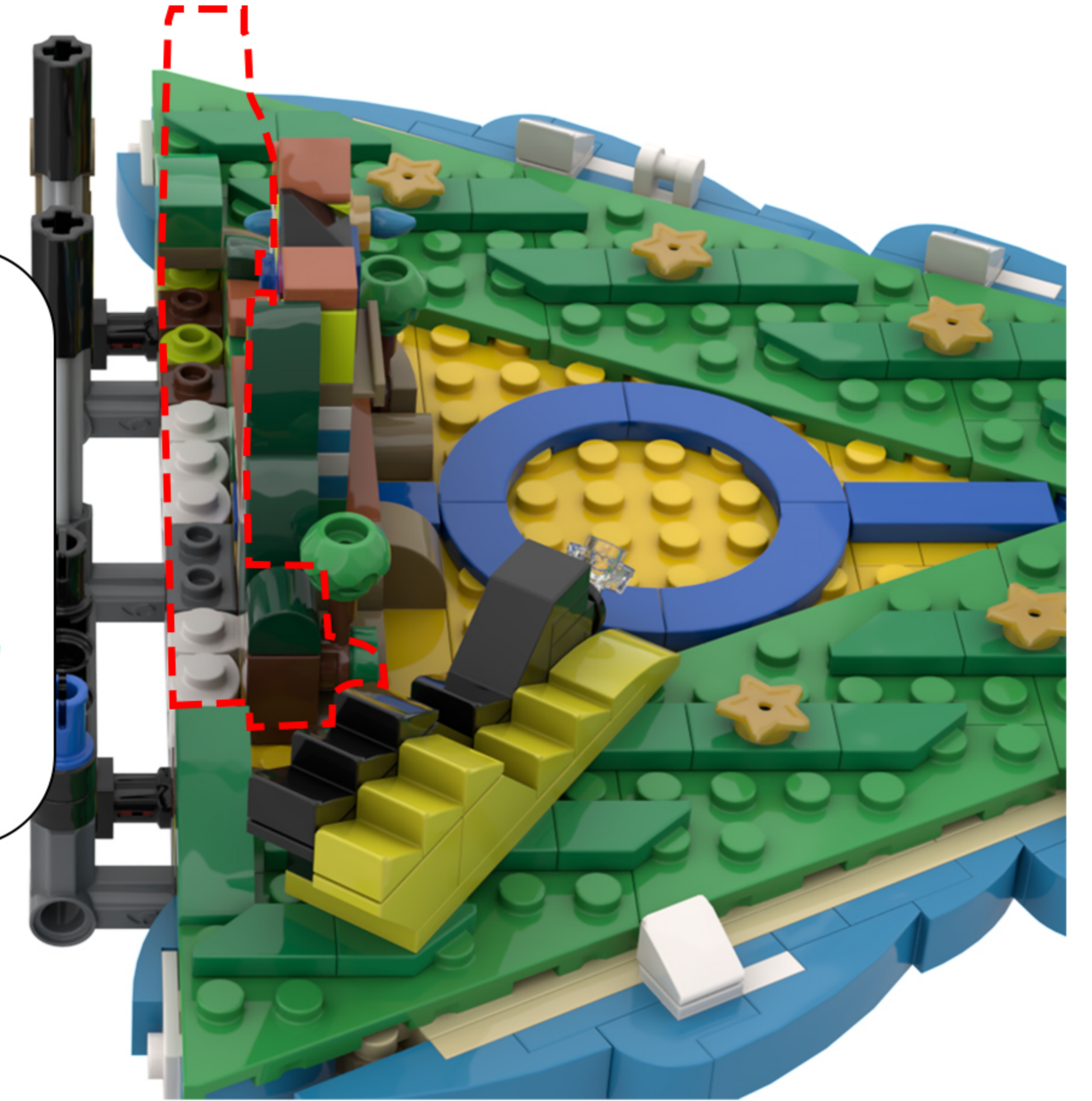
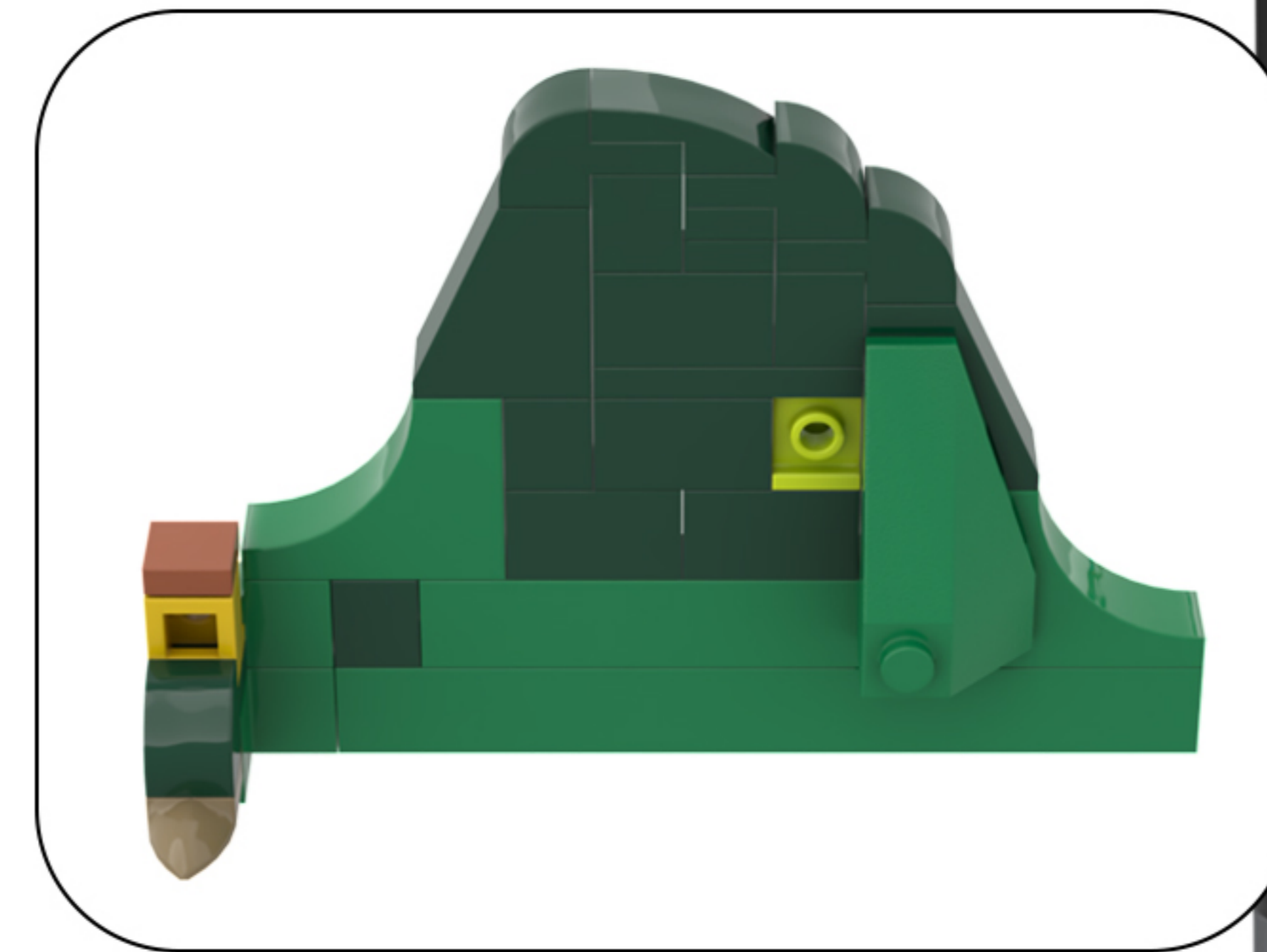

31

EN: Look at the block component highlighted in the image.

DE: Schauen Sie sich die im Bild hervorgehobene Blockkomponente an.

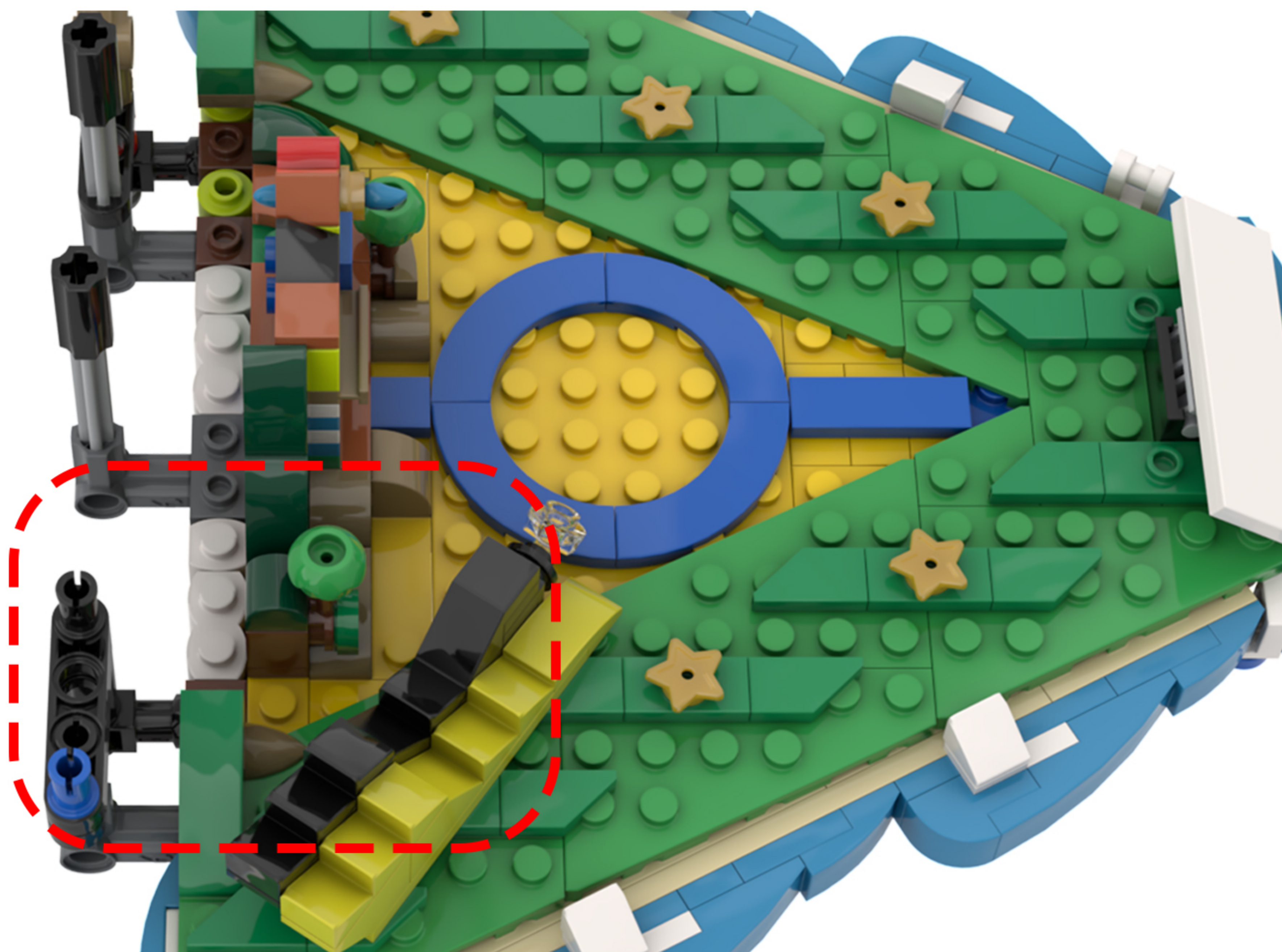

32

EN: Take the string of lights out of Bag 1 and place the cord over the building block as shown in the picture.

DE: Nimm die Lichterkette aus Beutel 1 heraus und lege das Kabel wie auf dem Bild gezeigt über den Baustein.

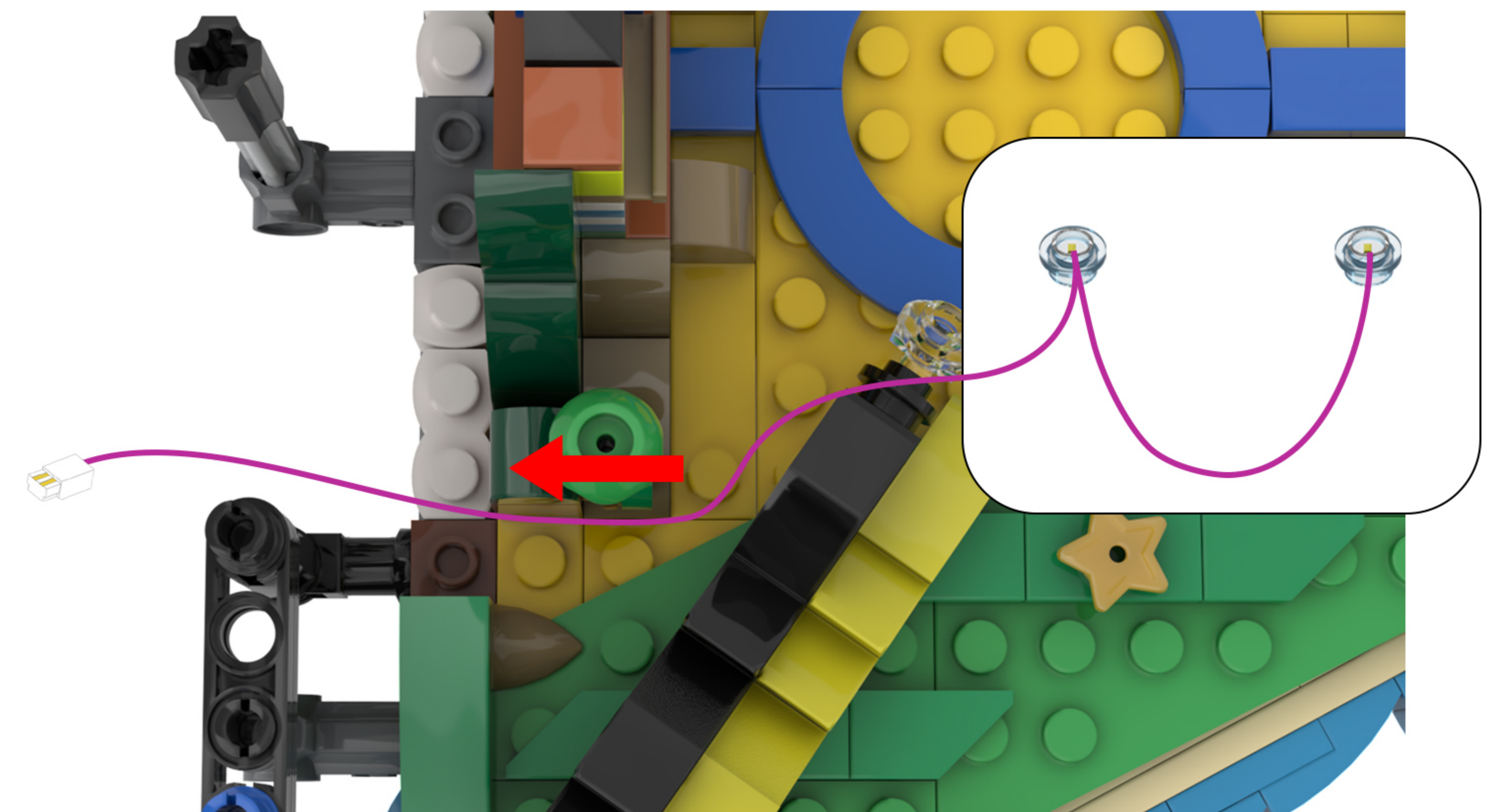
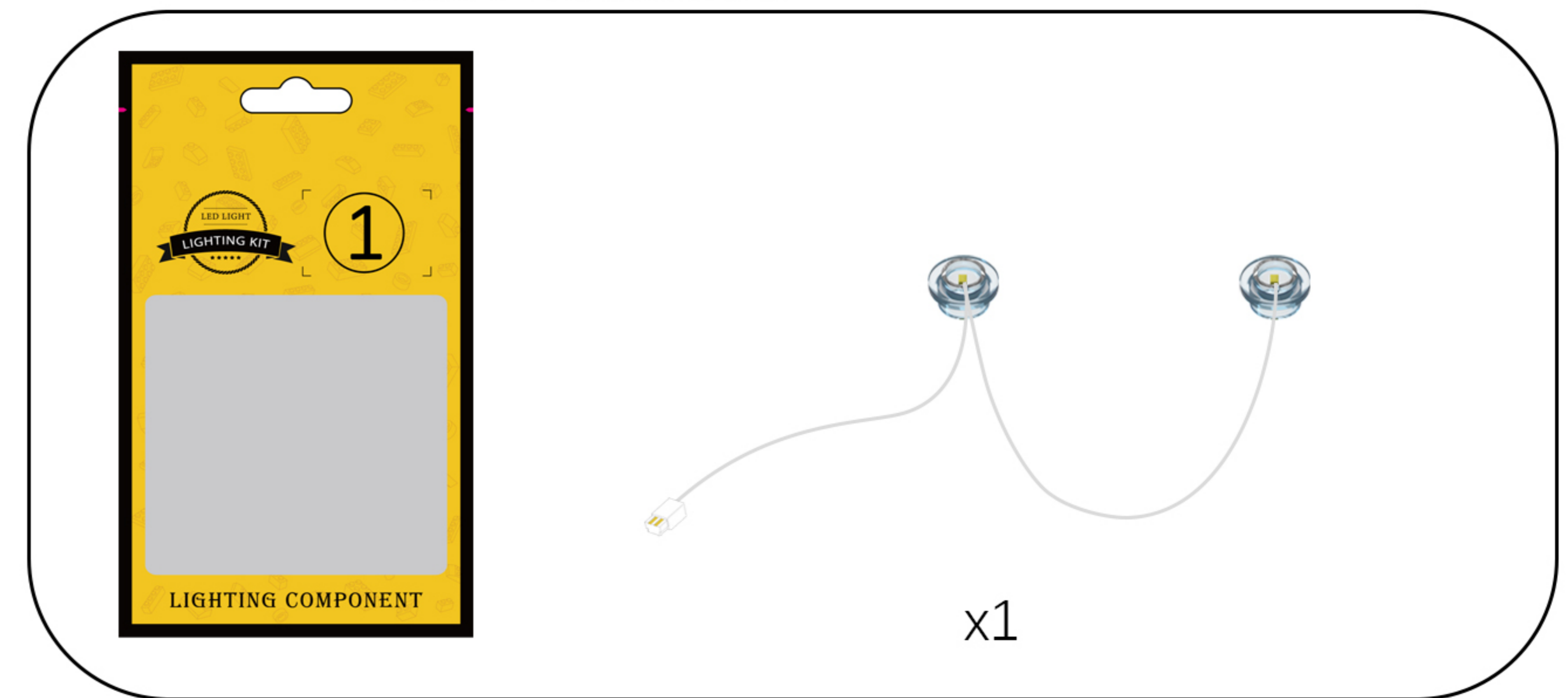

Note: Make sure to route the light cord away from the protrusions on the building blocks.

33

EN: Take out the disassembled building blocks, reassemble them, and secure the light cord.

DE: Nehmen Sie die zerlegten Bausteine heraus, setzen Sie sie wieder zusammen und befestigen Sie das Lichtkabel.

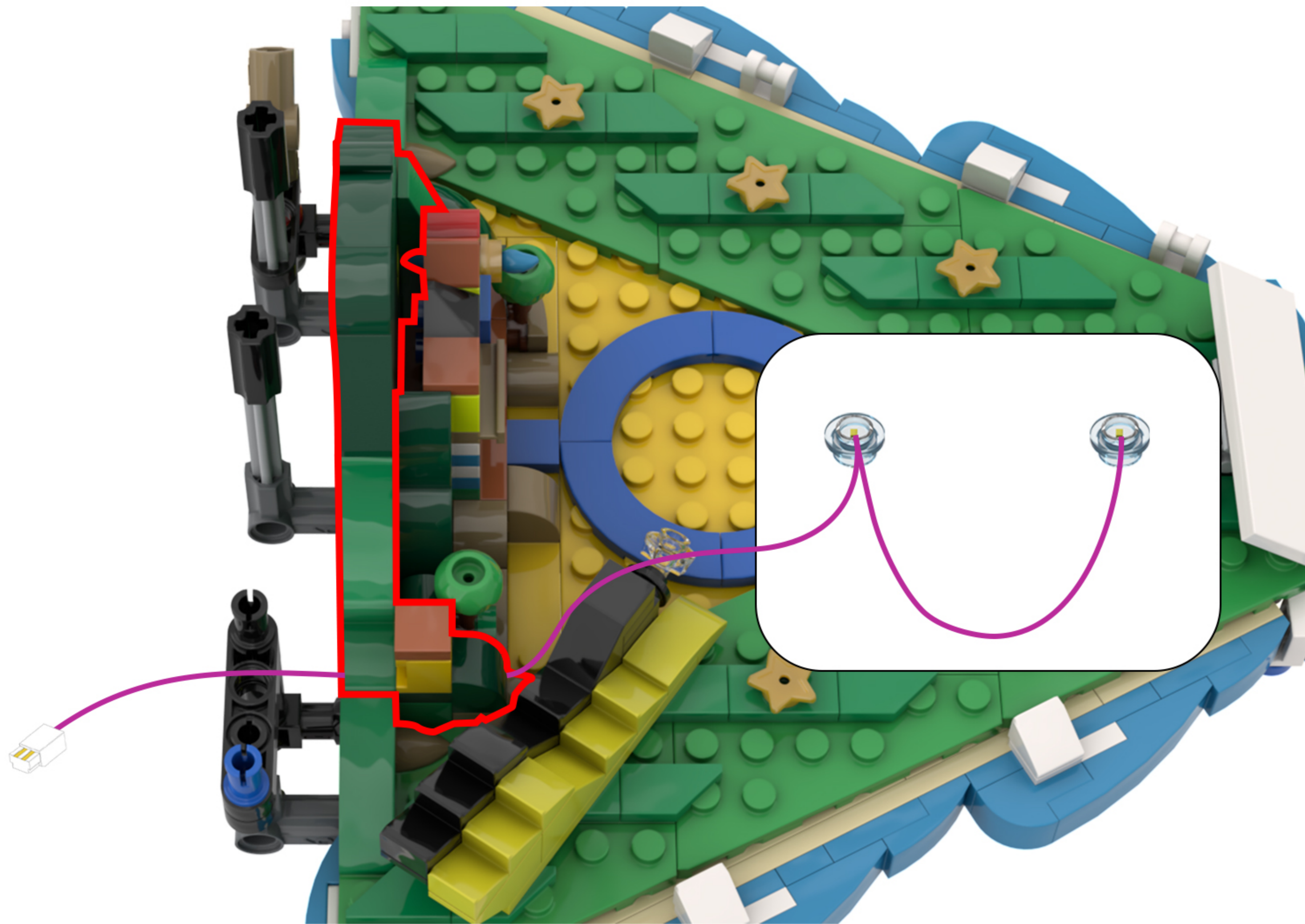
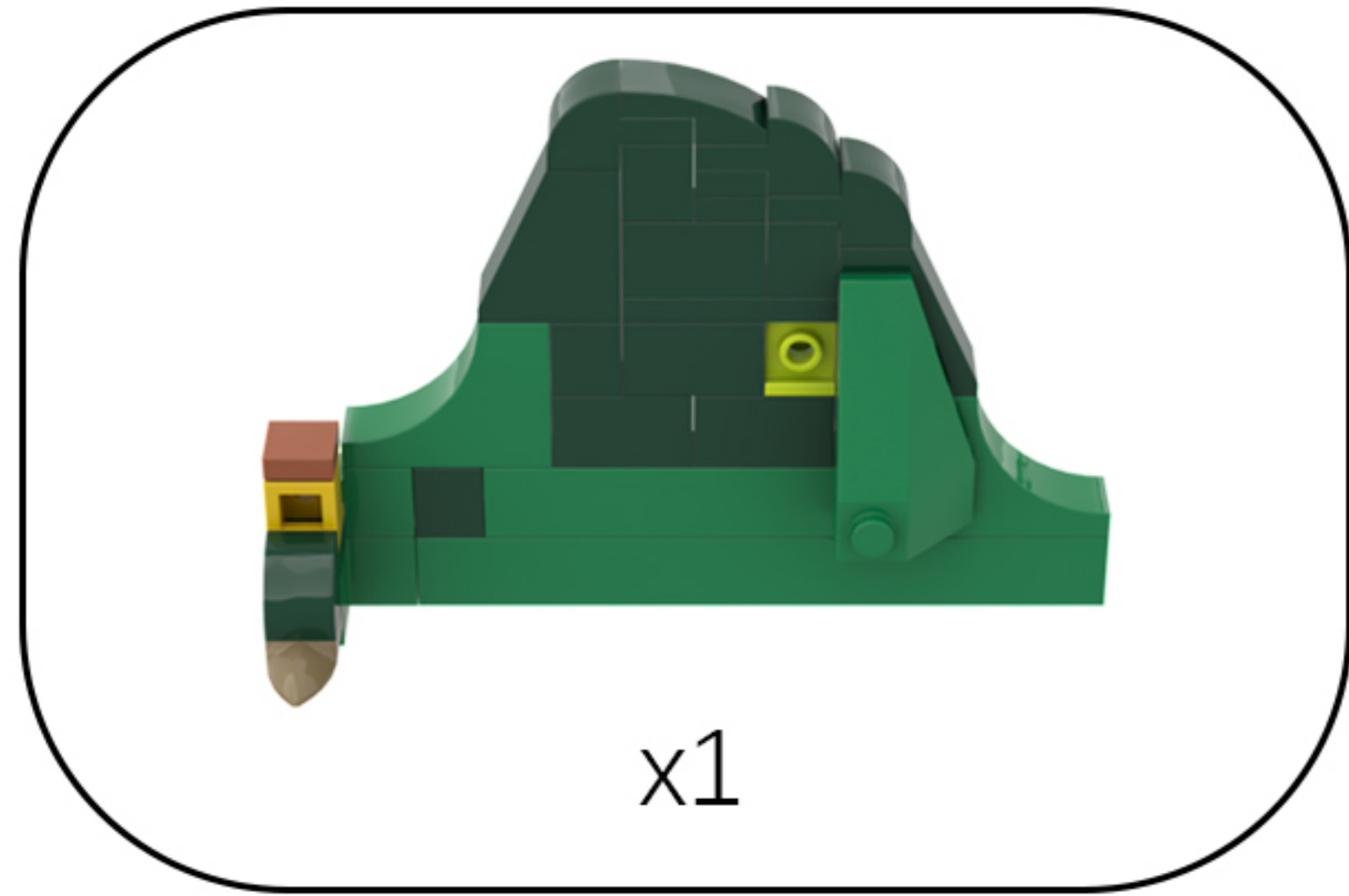

34

EN: Rotate the model to its back side.

DE: Drehen Sie das Modell auf die Rückseite.

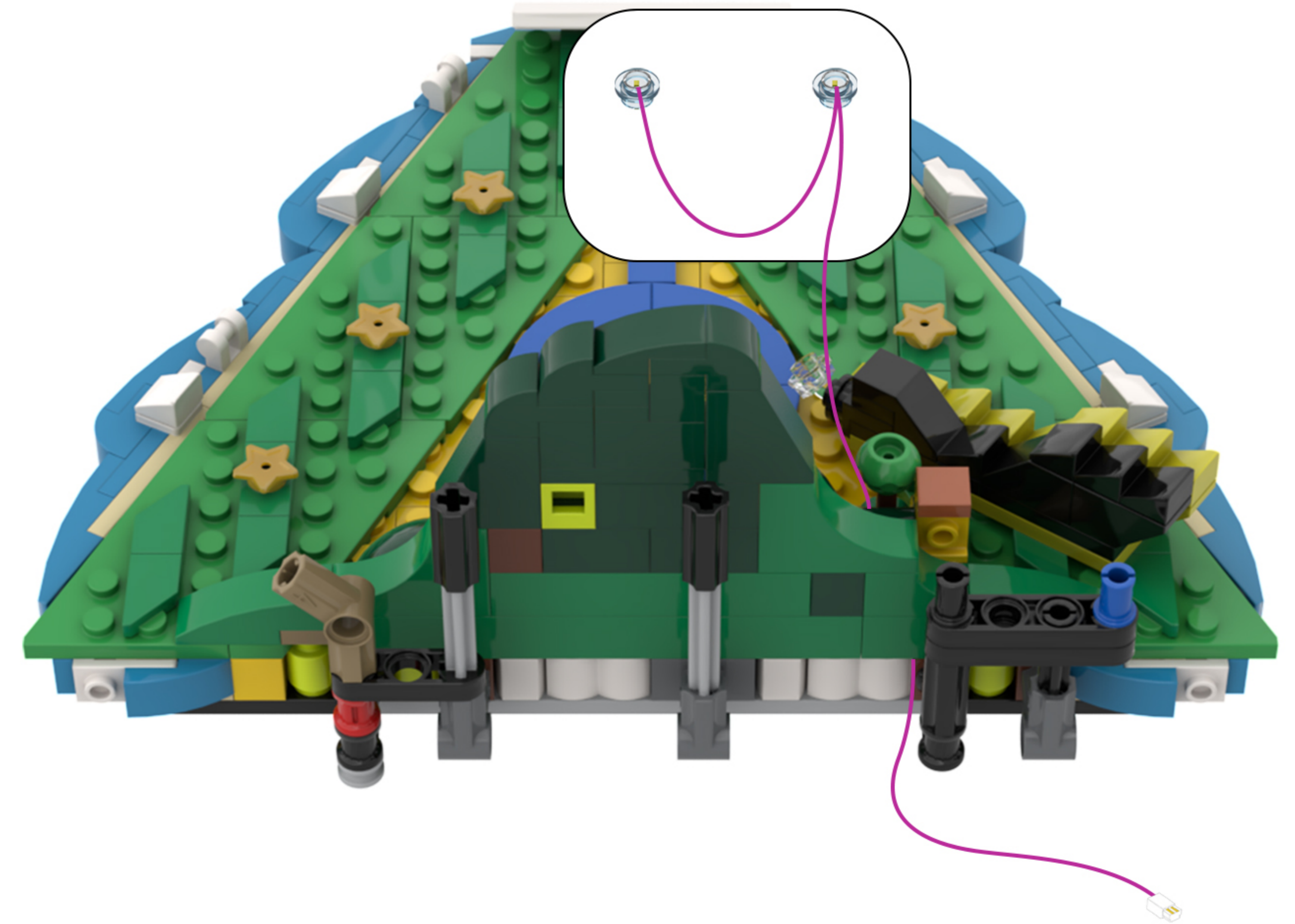

35

EN: Take out the building blocks with the lights attached and reassemble them in order.

DE: Nimm die Bausteine mit den daran befestigten Lichtern heraus und setze sie der Reihe nach wieder zusammen.

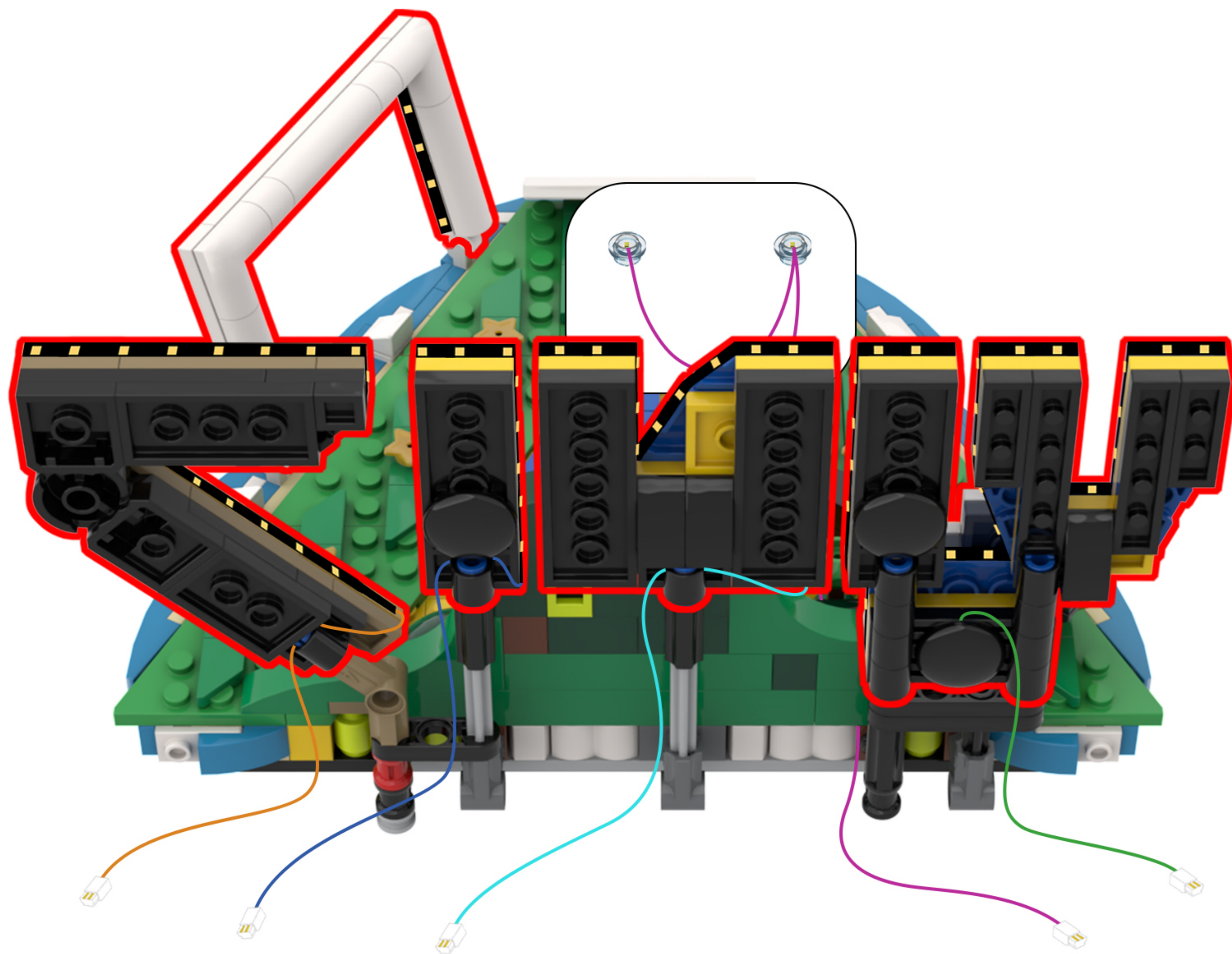
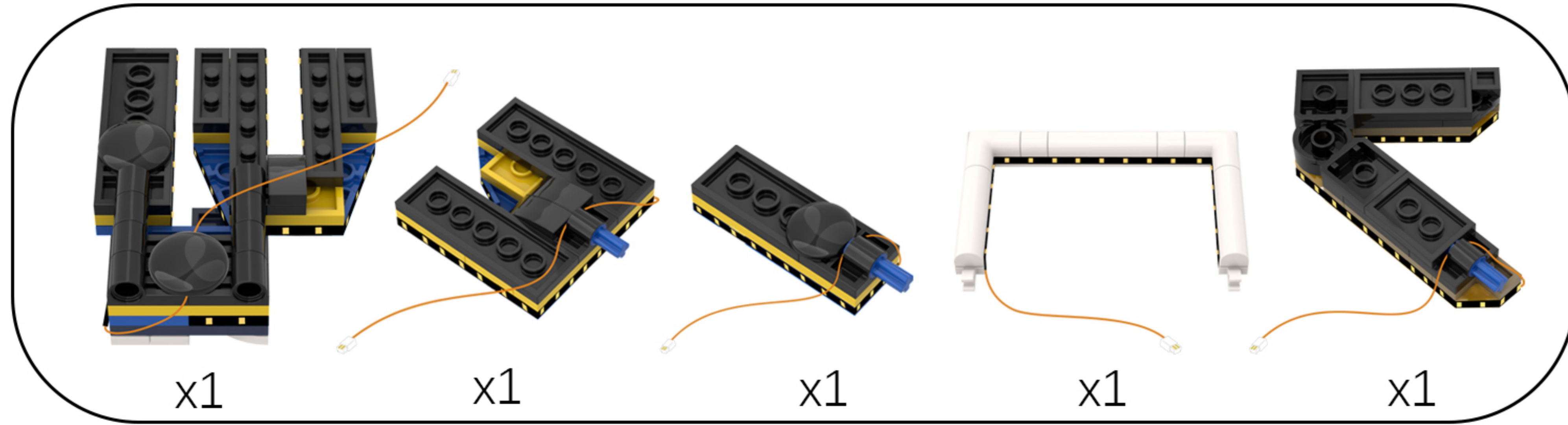

36

EN: Locate the two light wires in the diagram.

DE: Suchen Sie die beiden Lichtkabel in der Abbildung.

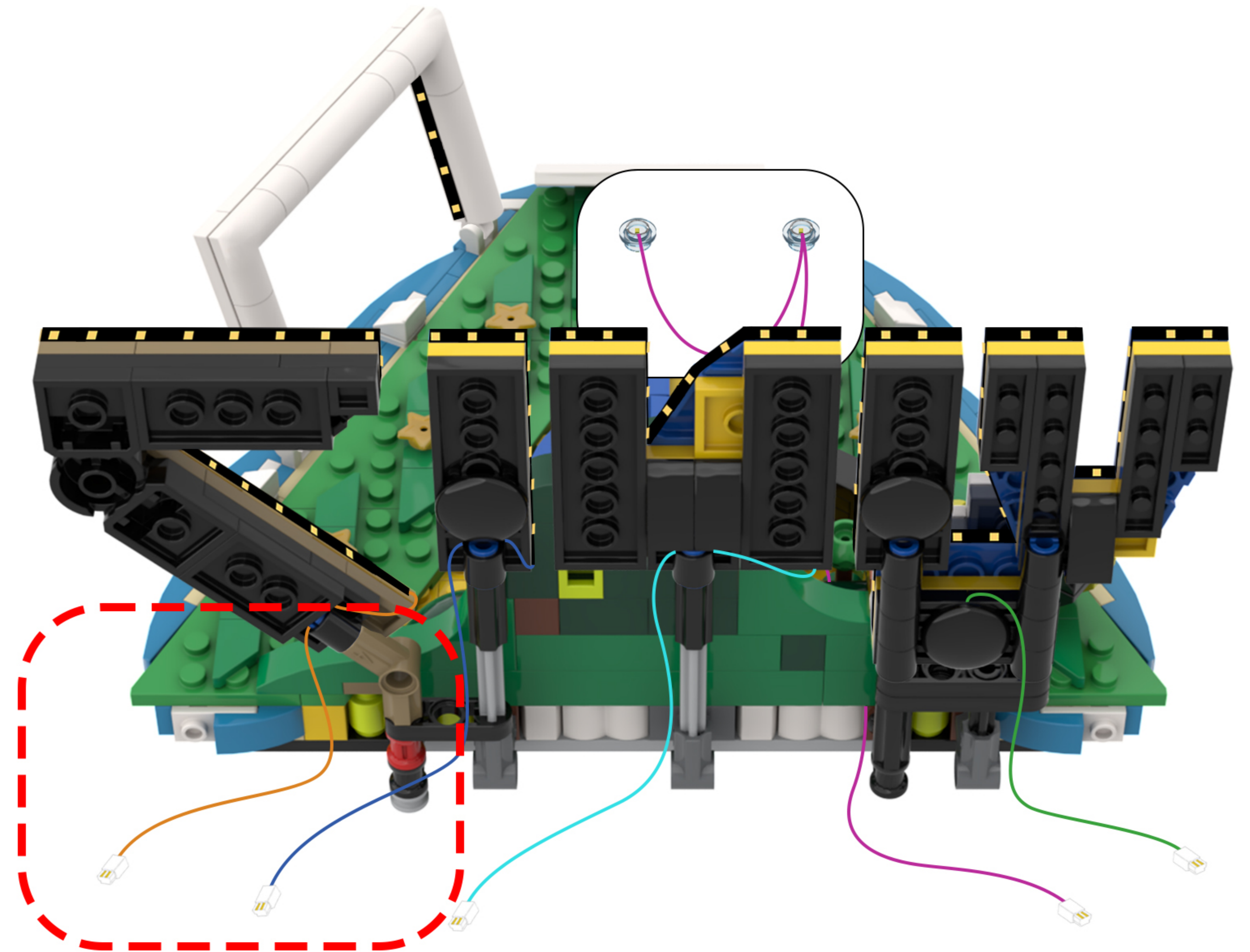

37

EN: Thread the light cord through the holes in the building blocks one by one.

DE: Führen Sie das Lichtkabel nacheinander durch die Löcher in den Bausteinen.

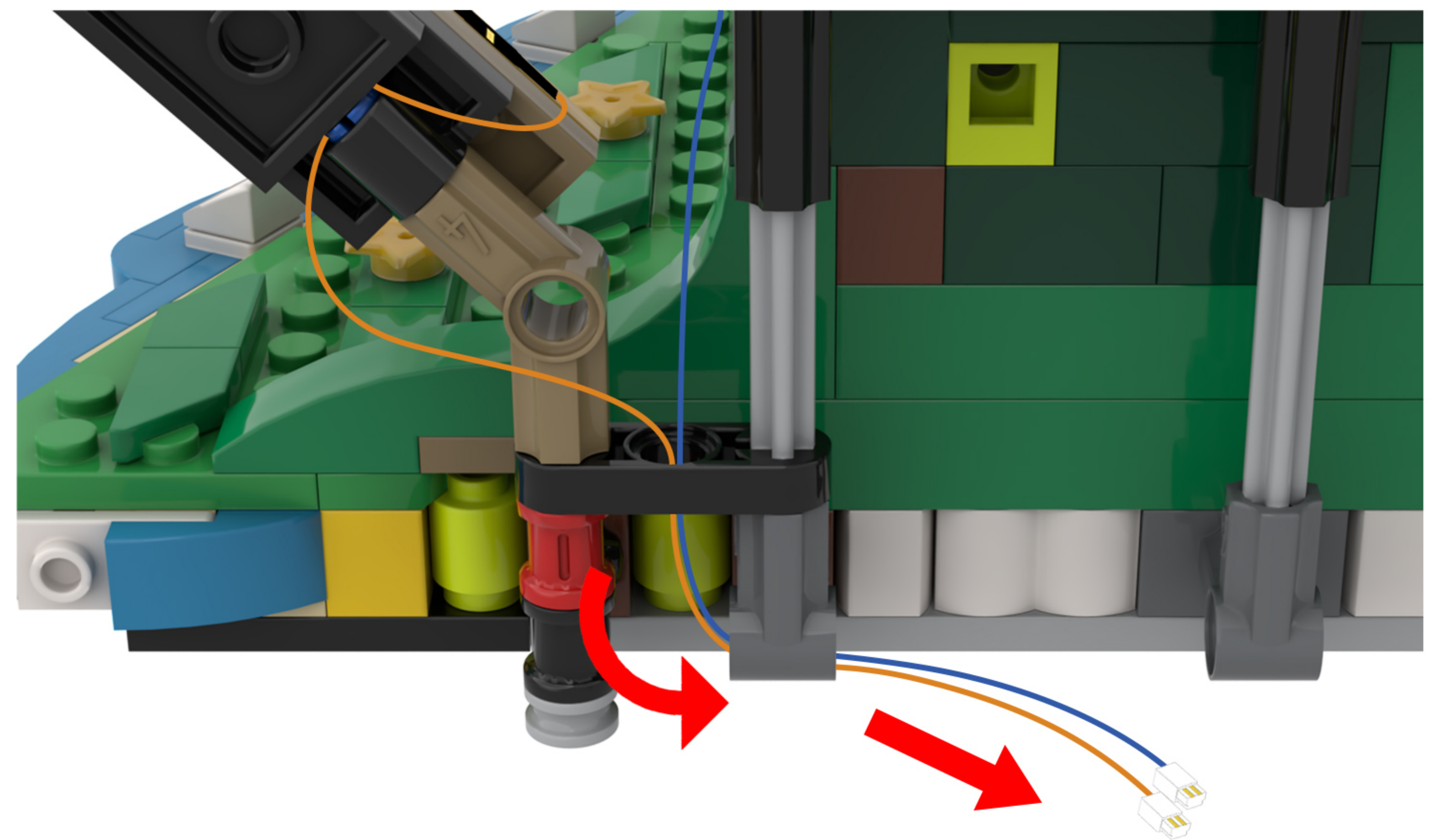
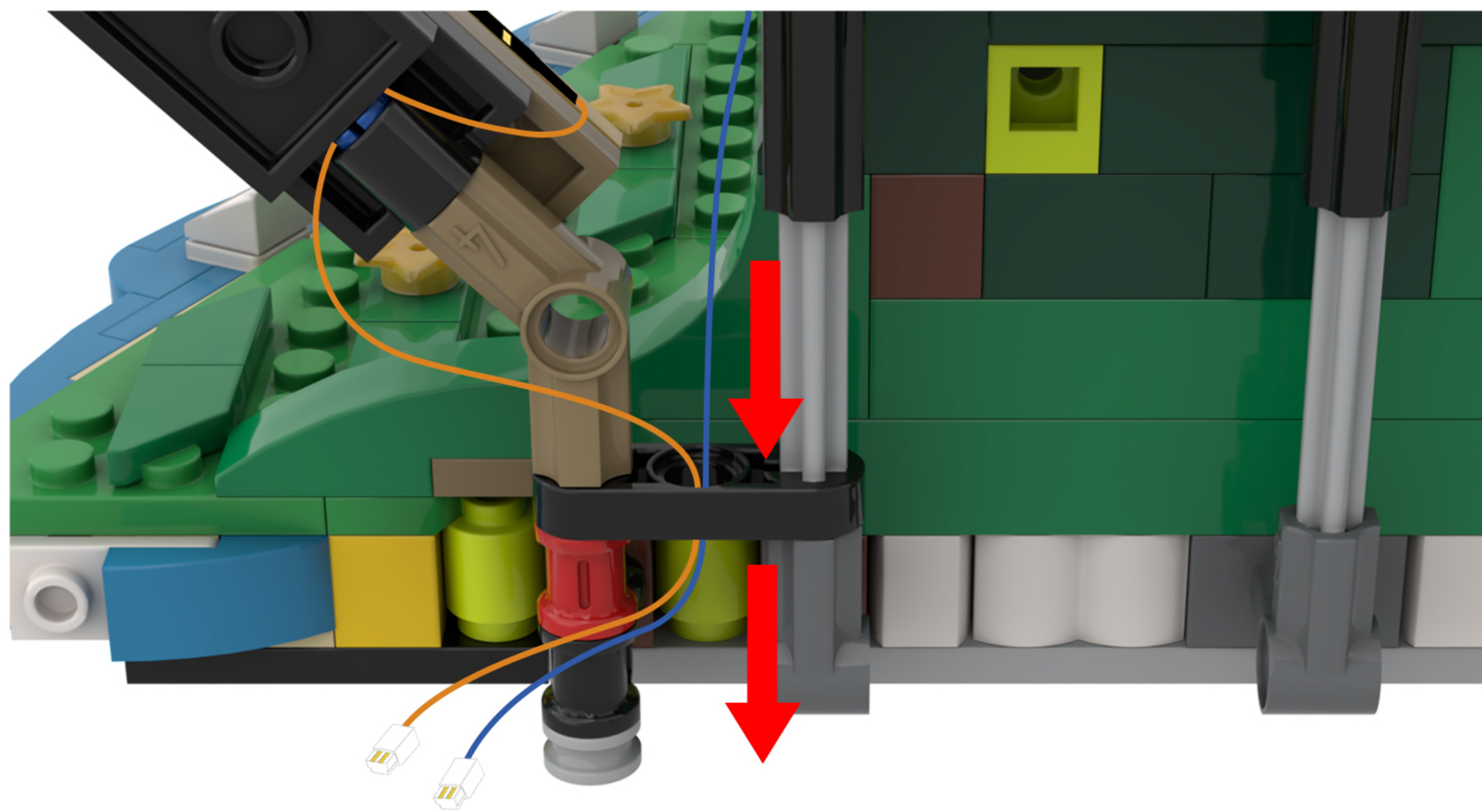

38

EN: Find the wire for the light fixture on the right.

DE: Suchen Sie das Kabel für die Leuchte auf der rechten Seite.

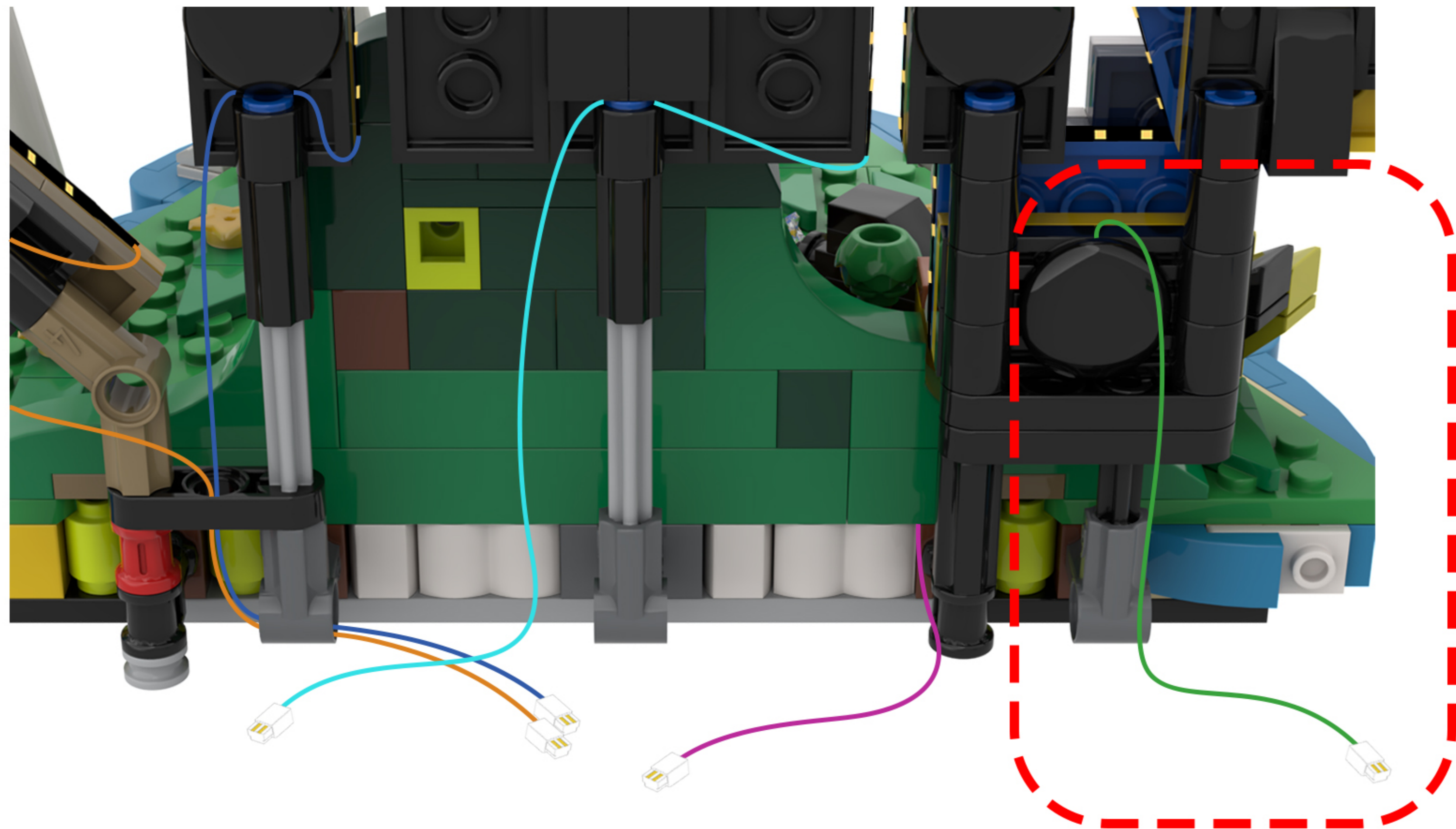

39

EN: Thread the lamp cord through the holes in the building blocks.

DE: Führen Sie das Lampenkabel durch die Löcher in den Bausteinen.

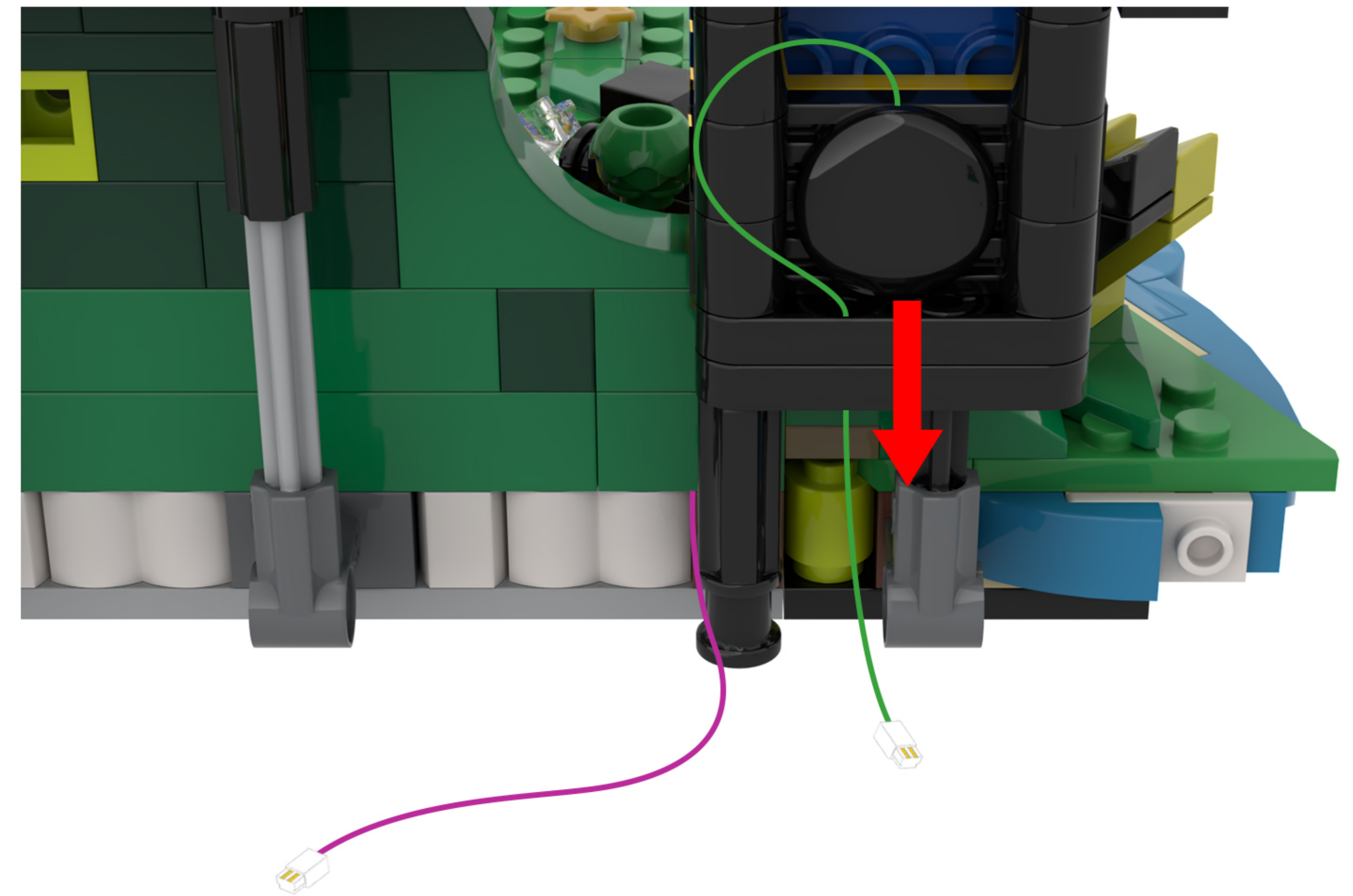

40

EN: Continue threading the light cord through the gaps in the building blocks, guiding it to the left.

DE: Führen Sie das Lichterkabel weiter durch die Lücken in den Bausteinen und lenken Sie es dabei nach links.

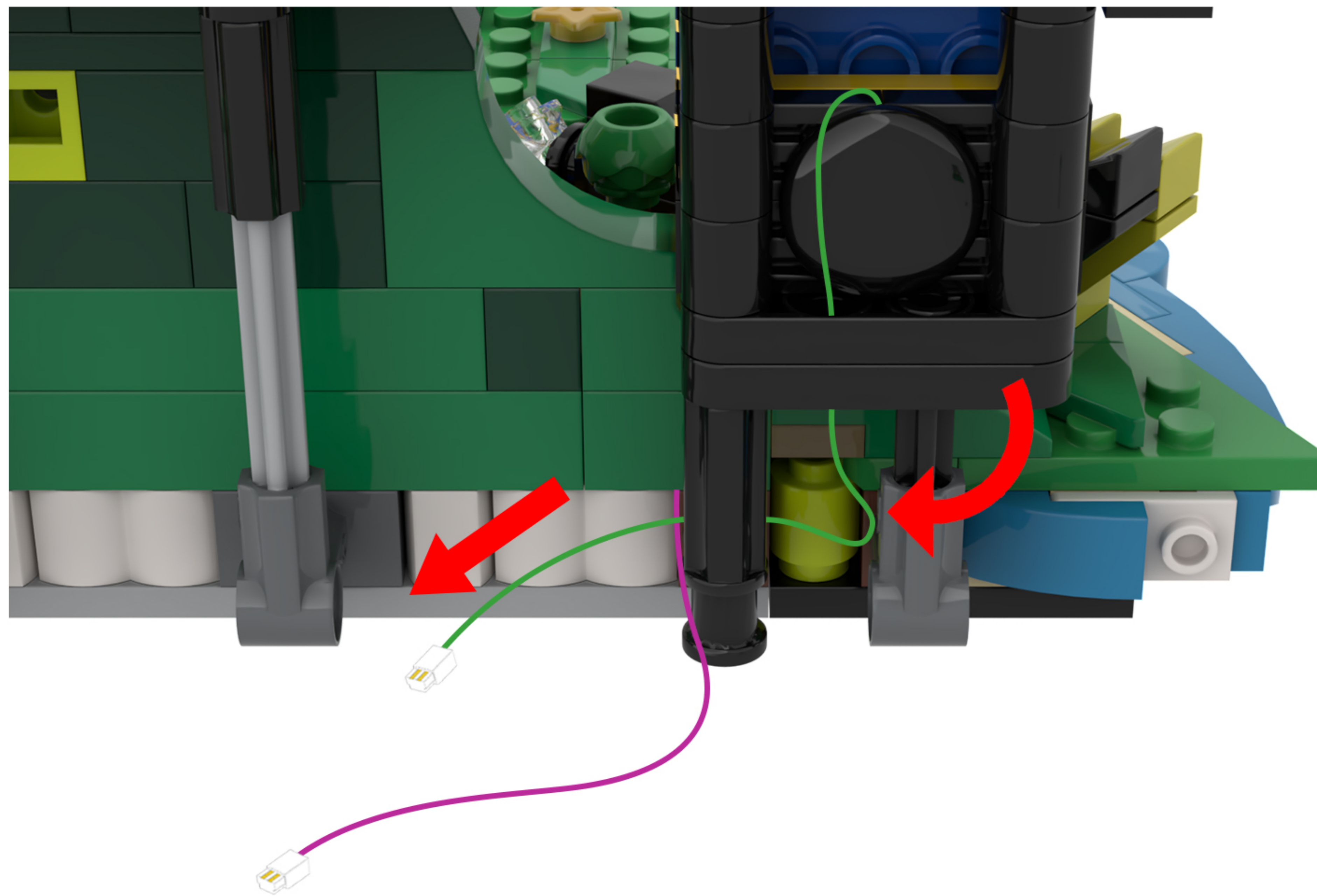

41

EN: Locate the three light wires in the diagram.

DE: Suchen Sie die drei Lichtkabel in der Abbildung.

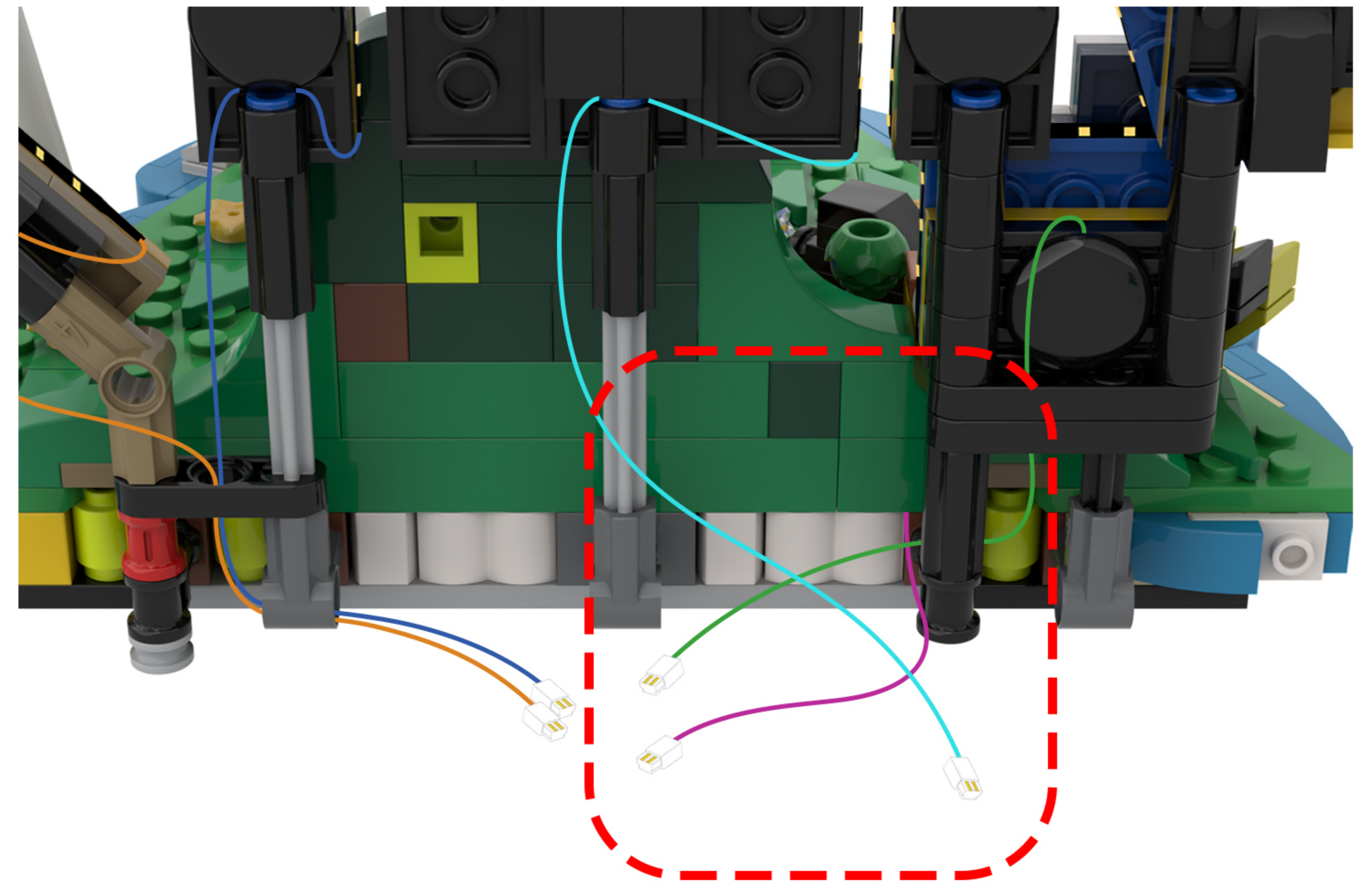

42

EN: Thread the wires from the three string lights through the holes in the building blocks one by one, guiding them to the left.

DE: Führen Sie die Drähte der drei Lichterketten nacheinander durch die Löcher in den Bausteinen und führen Sie sie dabei nach links.

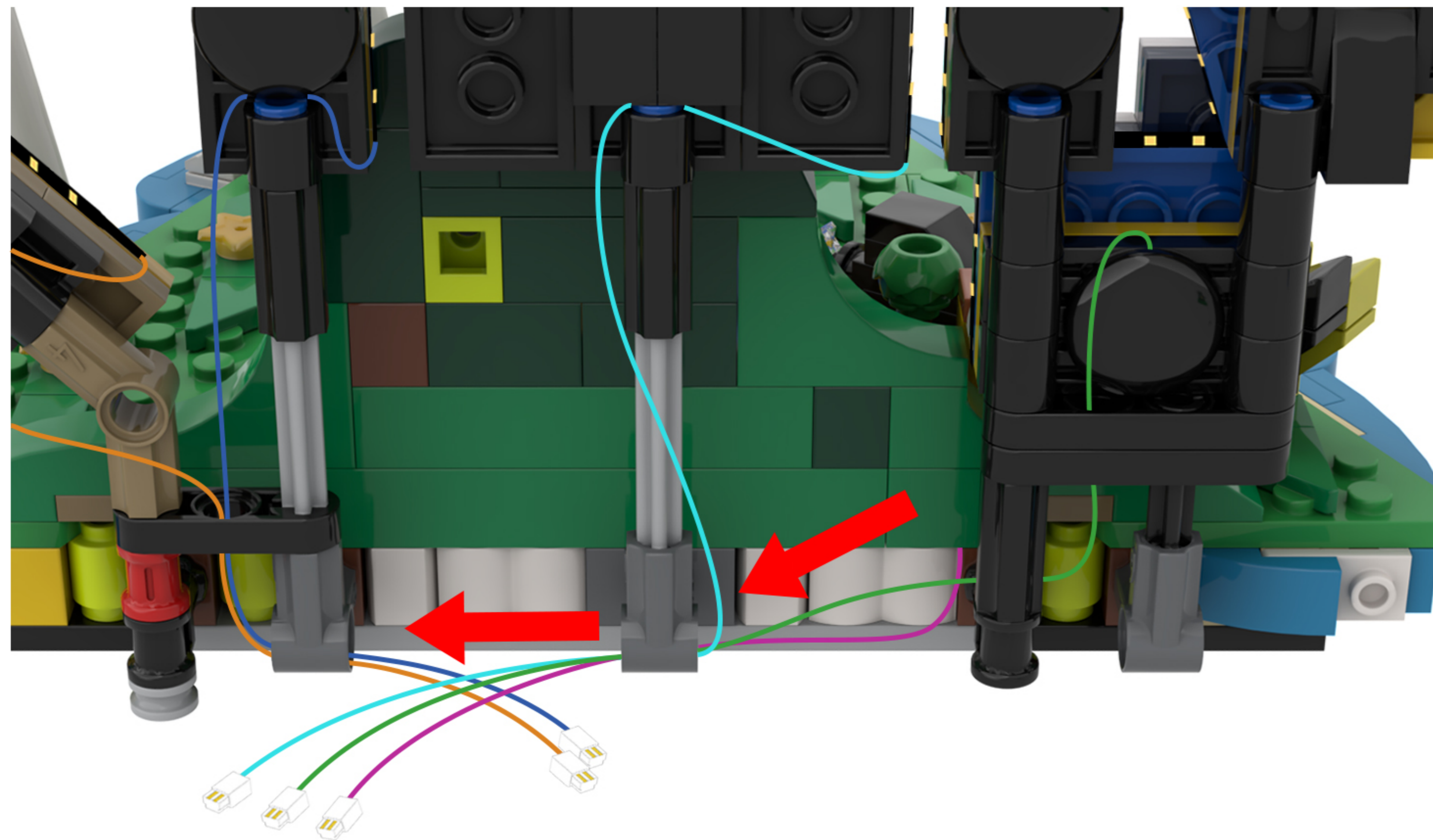

43

EN: Rotate the model to the side.

DE: Drehen Sie das Modell zur Seite.

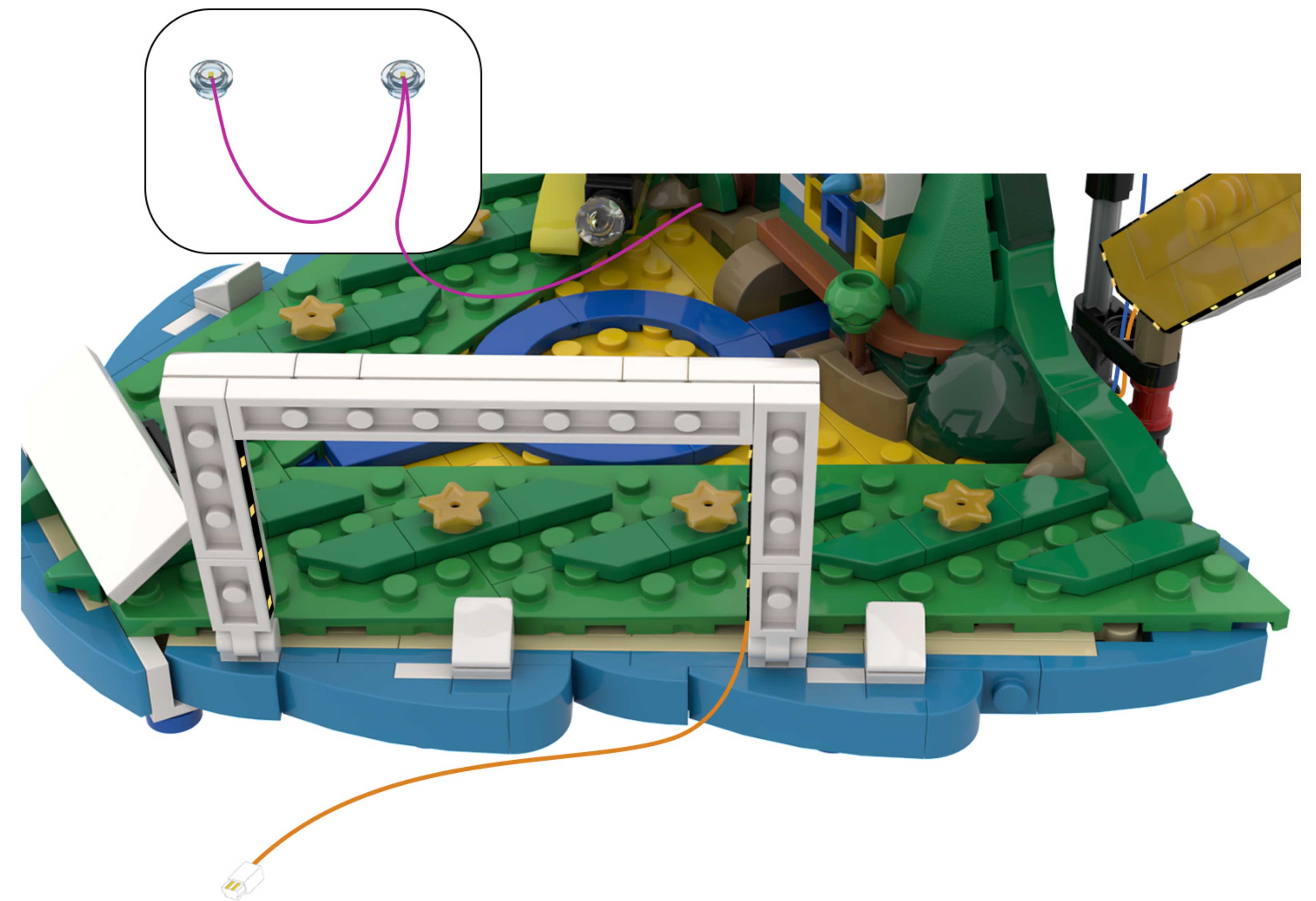

44

EN: Remove the building blocks.

DE: Entfernen Sie die Bausteine.

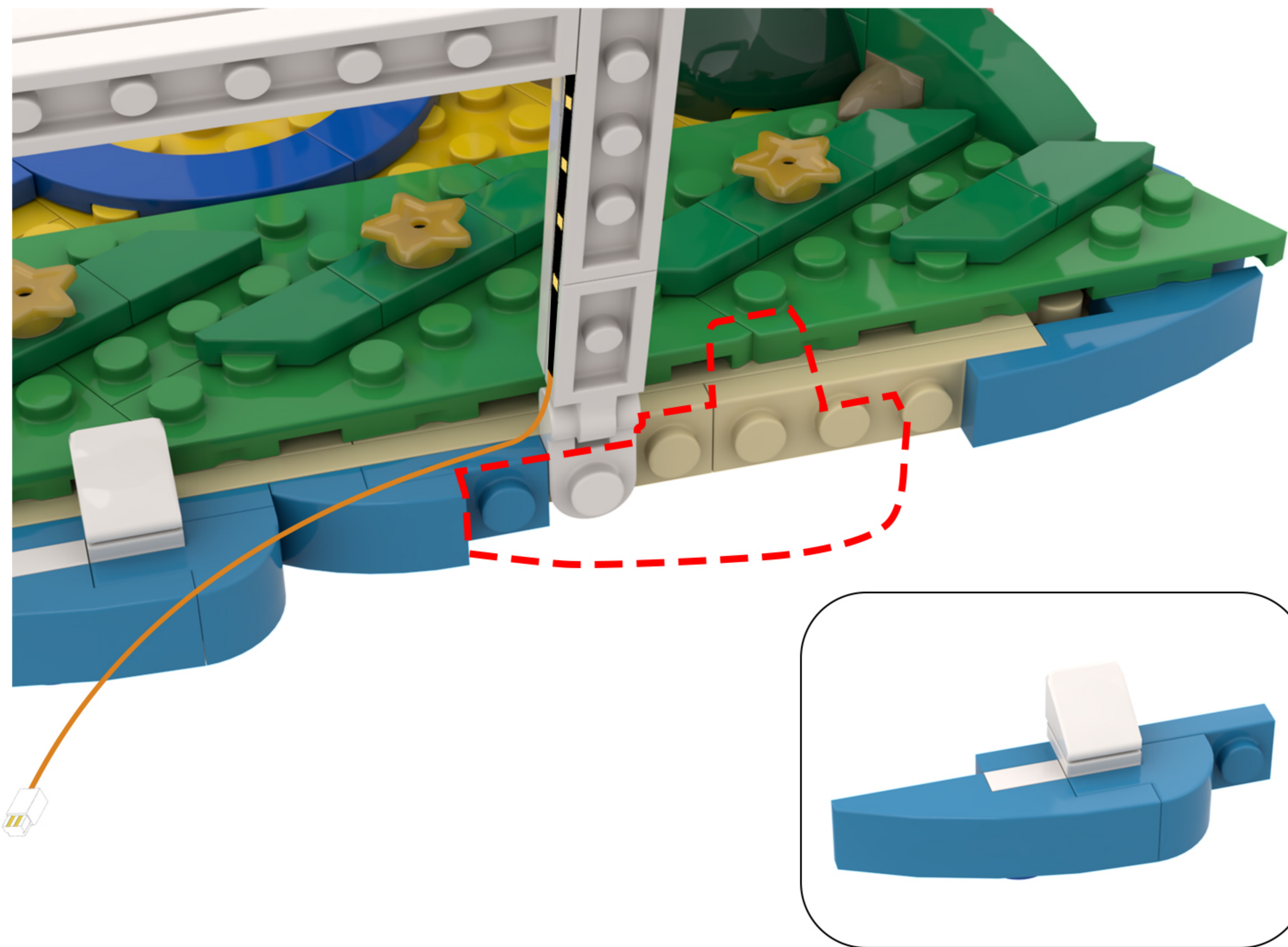

45

EN: Place the light cord between the protrusions on the building blocks.

DE: Führen Sie das Lichtkabel zwischen den Vorsprüngen der Bausteine hindurch.

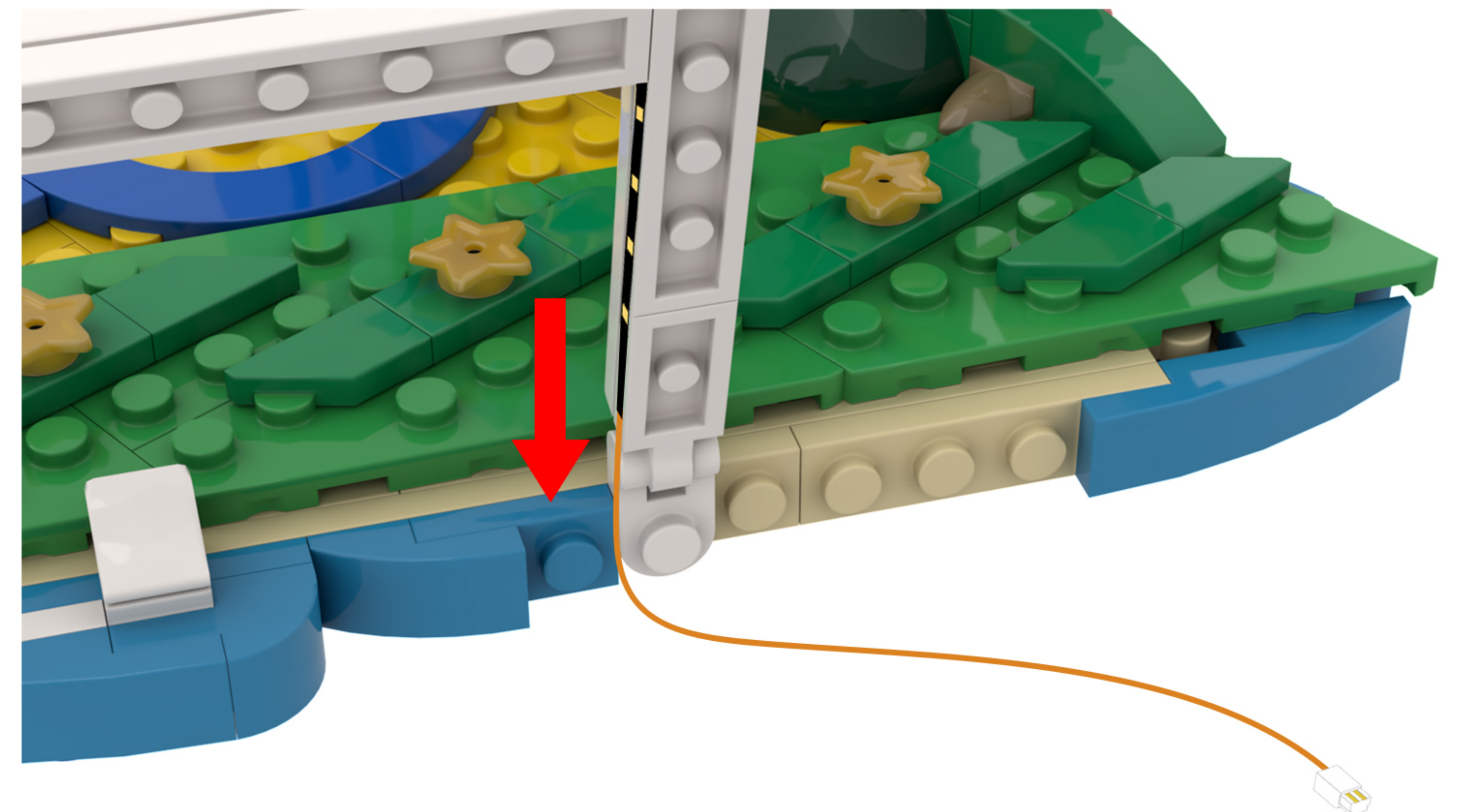

46

EN: Take out the disassembled building blocks, reassemble them, and secure the light cord.

DE: Nehmen Sie die zerlegten Bausteine heraus, setzen Sie sie wieder zusammen und befestigen Sie das Lichtkabel.

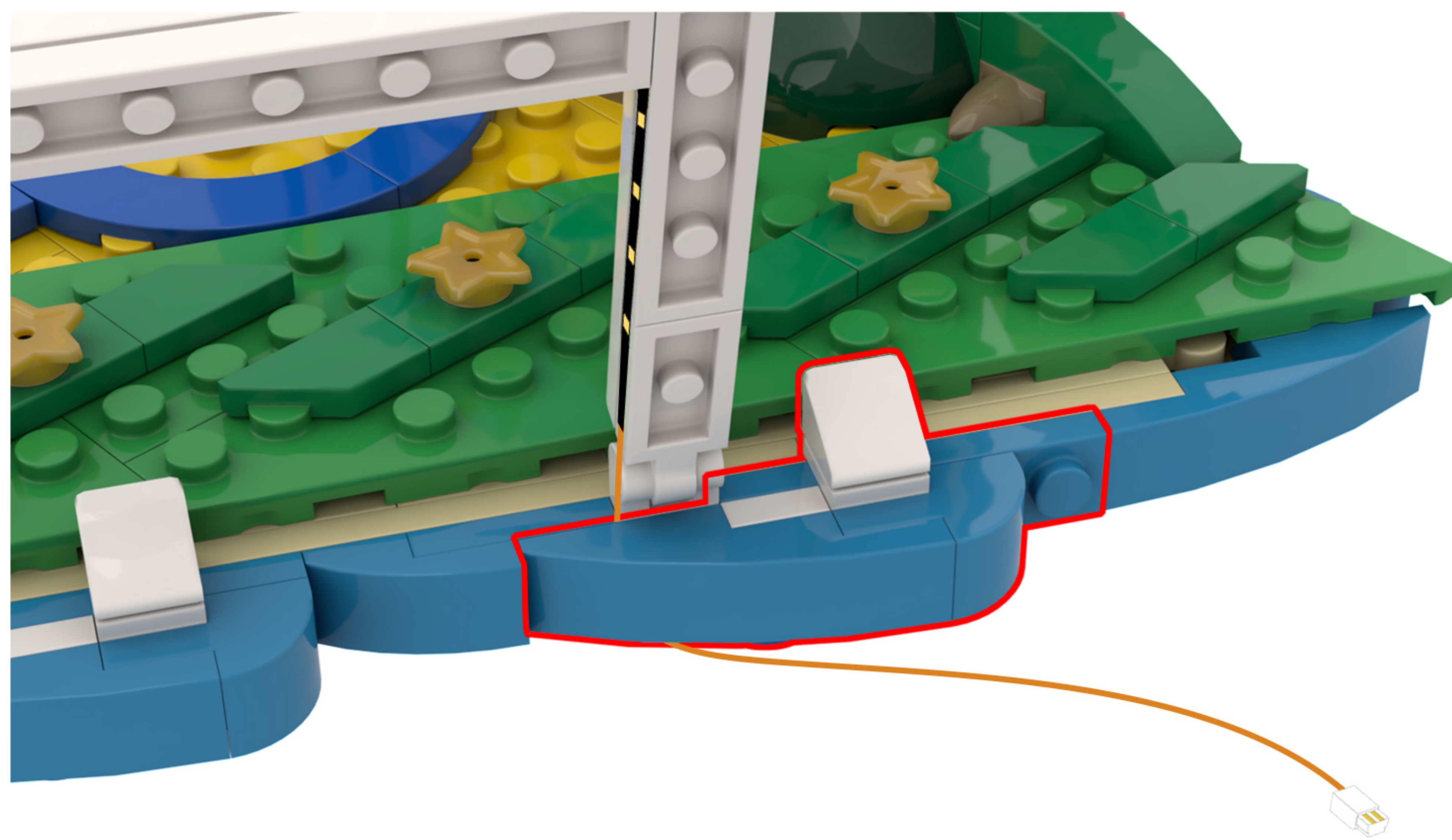
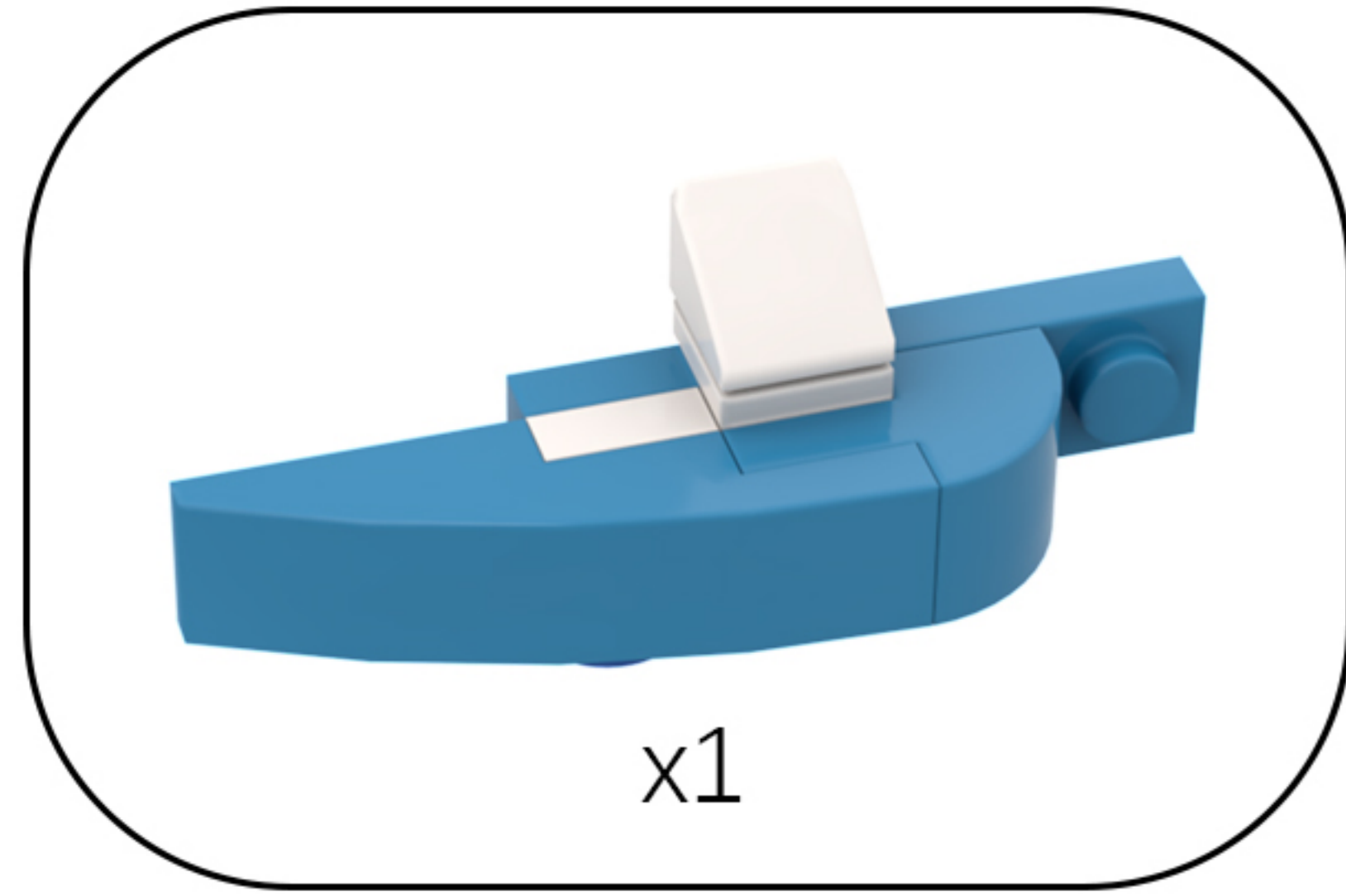

47

EN: Rotate the model to the perspective shown in the figure.

DE: Drehen Sie das Modell so, dass es der in der Abbildung gezeigten Perspektive entspricht.

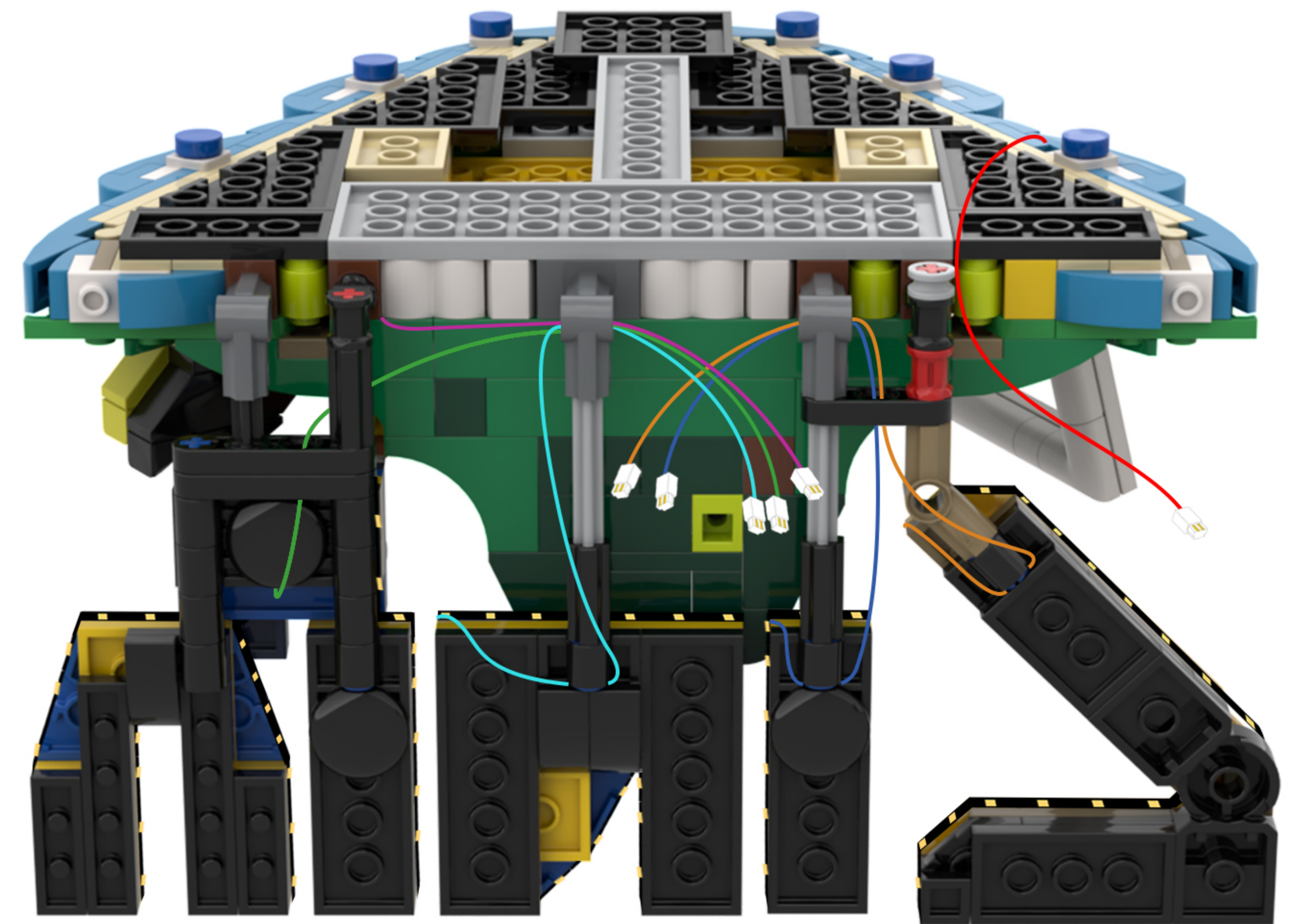
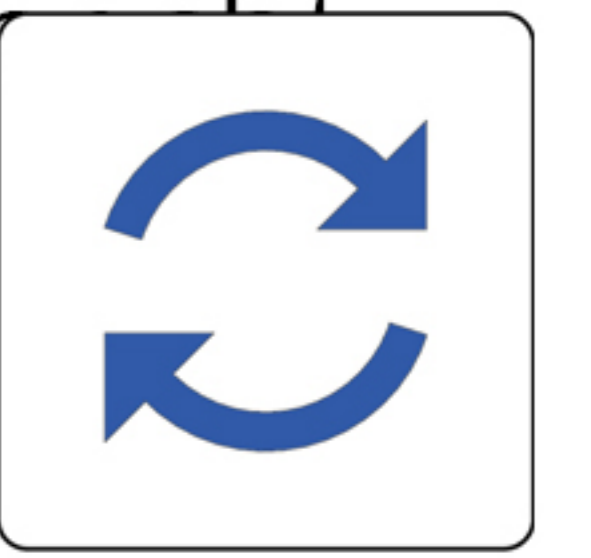

48

EN: Locate the light cord shown in the picture and thread it through the hole in the building block.

DE: Suchen Sie das auf dem Bild gezeigte Lichtkabel und führen Sie es durch die Öffnung im Baustein.

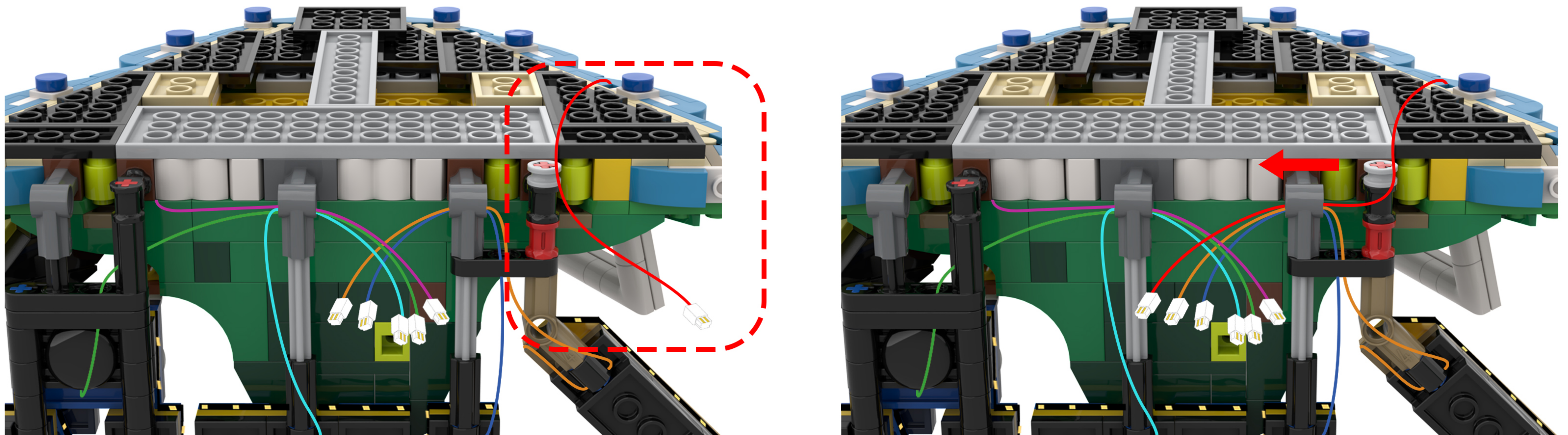

49

EN: Twist the wires from the 6 string lights together.

DE: Verdrehen Sie die Drähte der 6-Licht-Lichterkette miteinander.

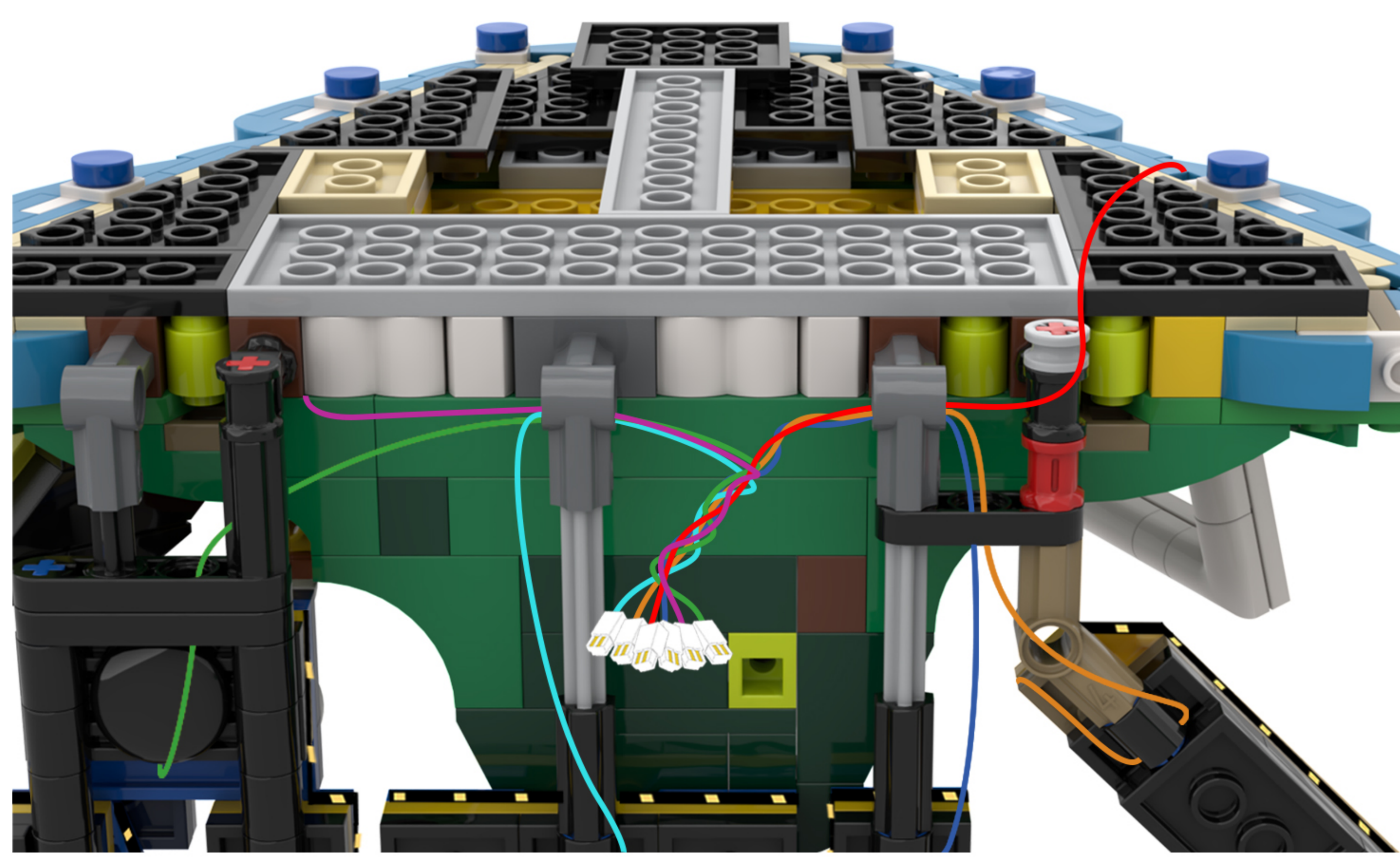

50

EN: Take the expansion board out of Bag 5 and connect the 6 light wires to the expansion board one by one.

DE: Nehmen Sie die Erweiterungsplatine aus Beutel 5 und schließen Sie die 6 Lichtkabel nacheinander an die Erweiterungsplatine an.

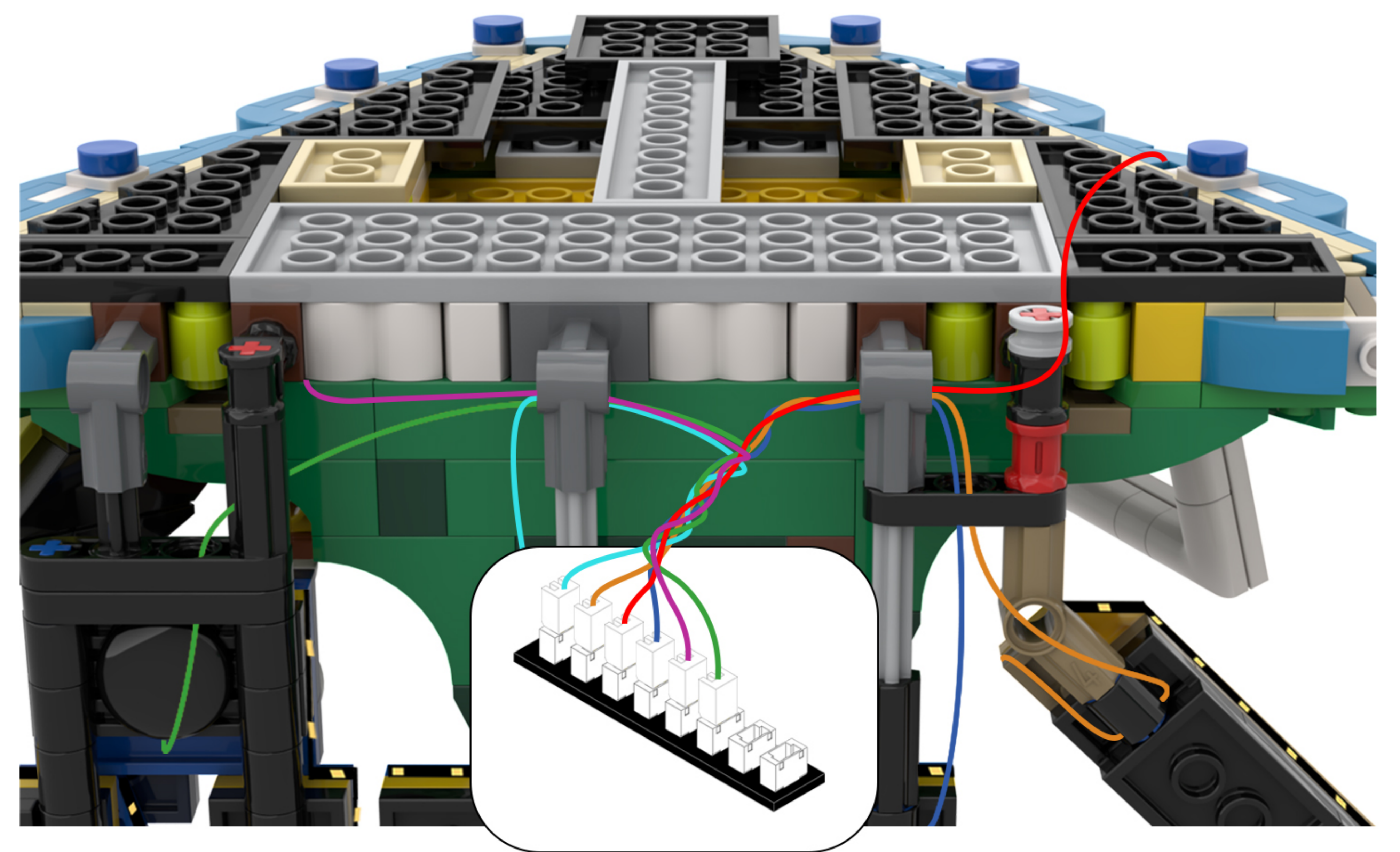
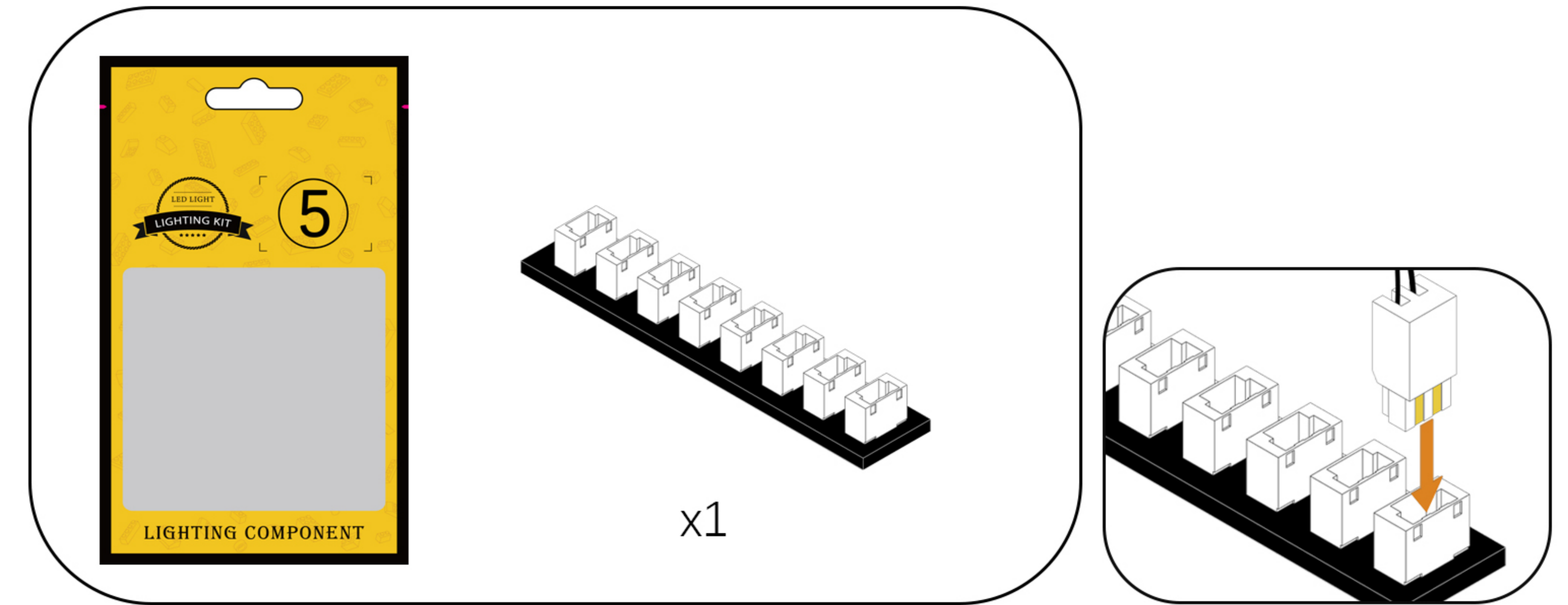

51

EN: Take the USB power cable out of the box and connect it to the expansion board.

DE: Nehmen Sie das USB-Stromkabel aus der Verpackung und schließen Sie es an die Erweiterungskarte an.

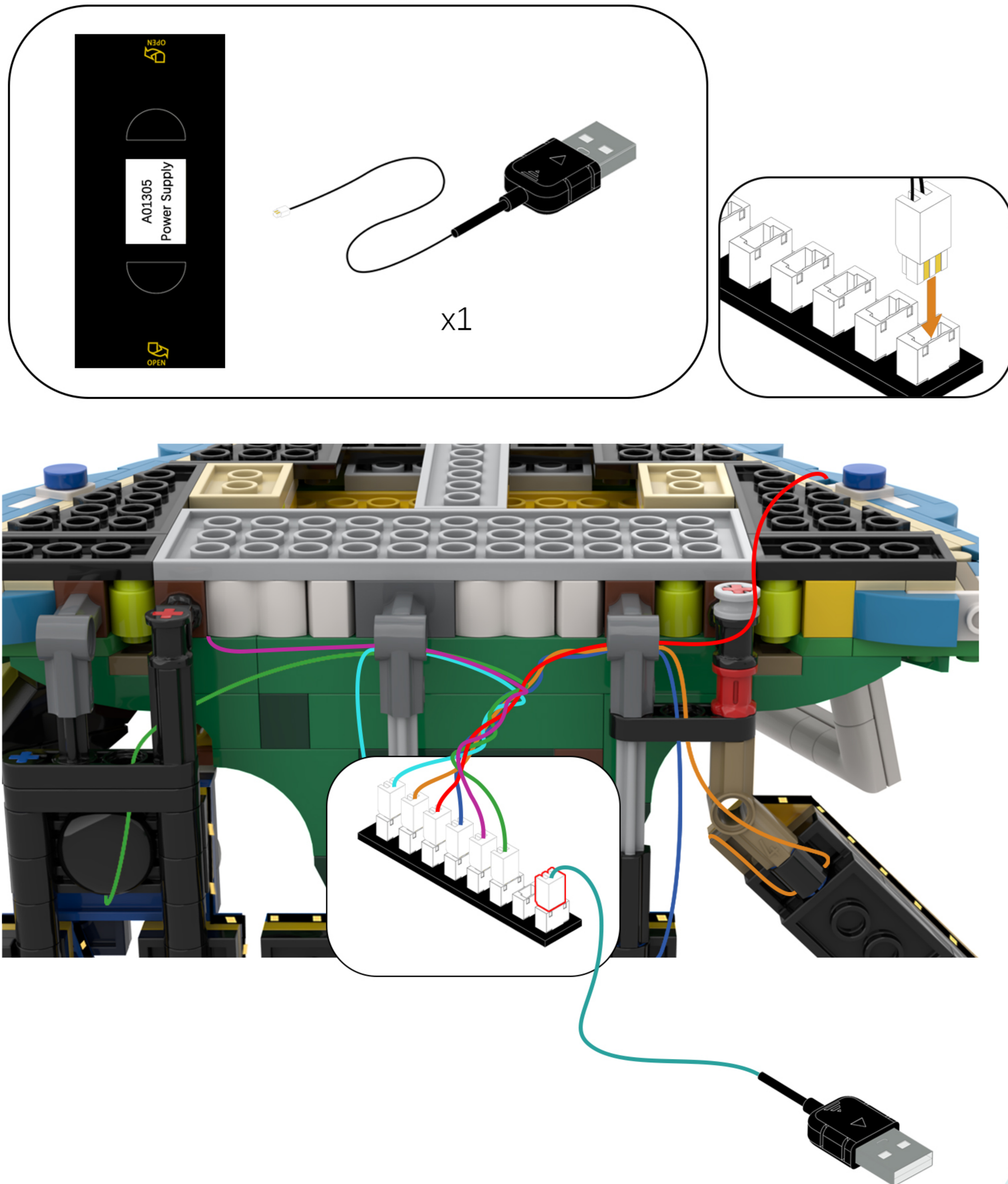

52

EN: Peel off the adhesive backing of the expansion board and attach it to the location shown in the illustration.

DE: Entfernen Sie die Schutzfolie von der Rückseite der Erweiterungsplatte und kleben Sie sie an die in der Abbildung gezeigte Stelle.

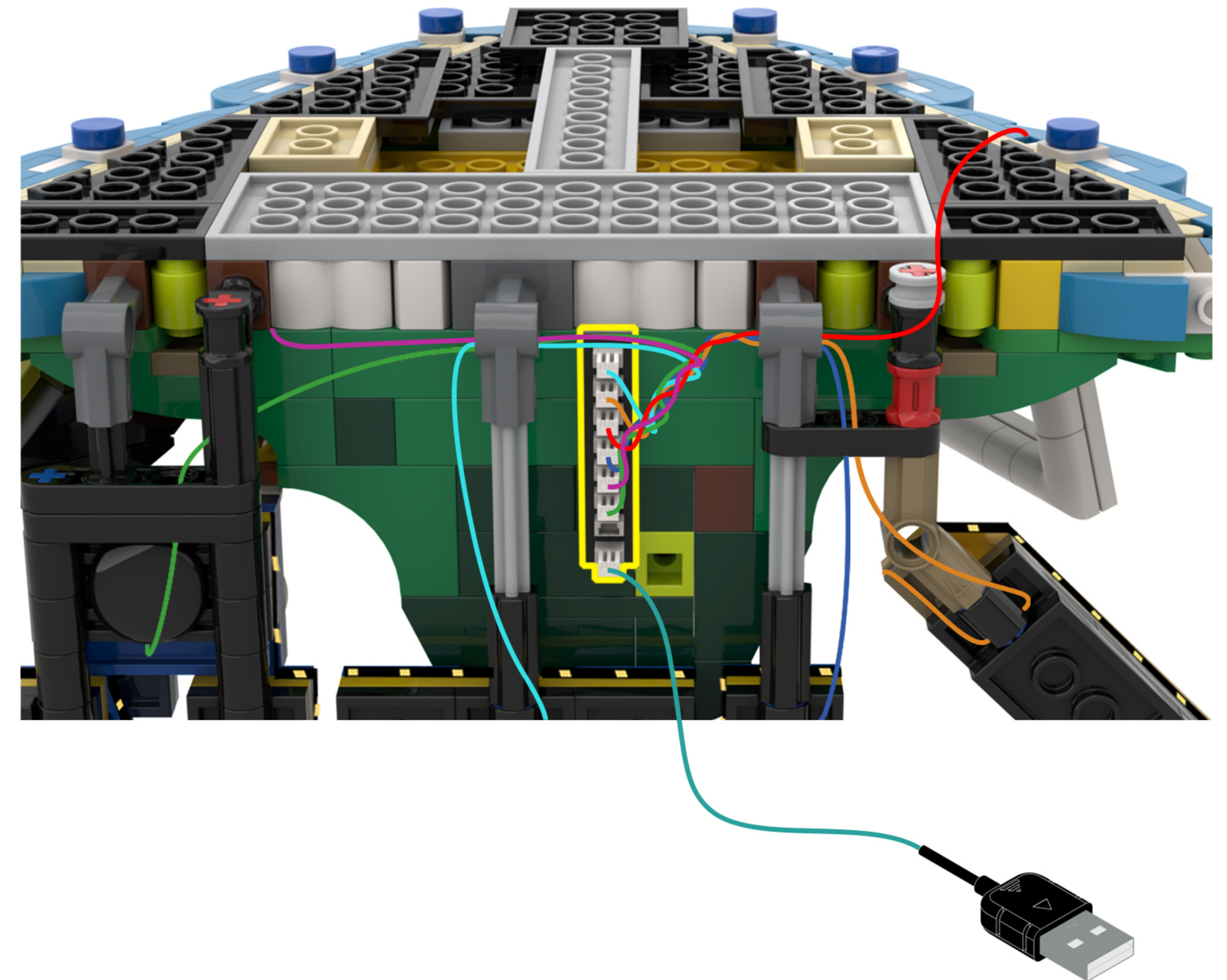

53

EN: Rotate the model to face you, and locate the string of lights from earlier.

DE: Drehen Sie das Modell so, dass es zu Ihnen zeigt, und suchen Sie die Lichterkette von vorhin.

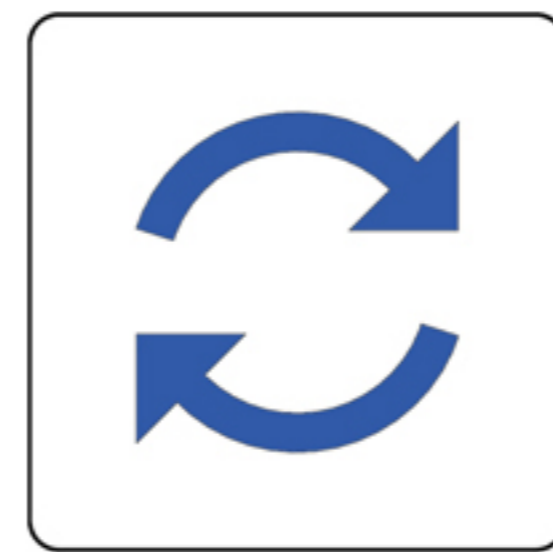

54

EN: Take out the disassembled building blocks and separate them.

DE: Nehmen Sie die zerlegten Bausteine heraus und trennen Sie sie voneinander.

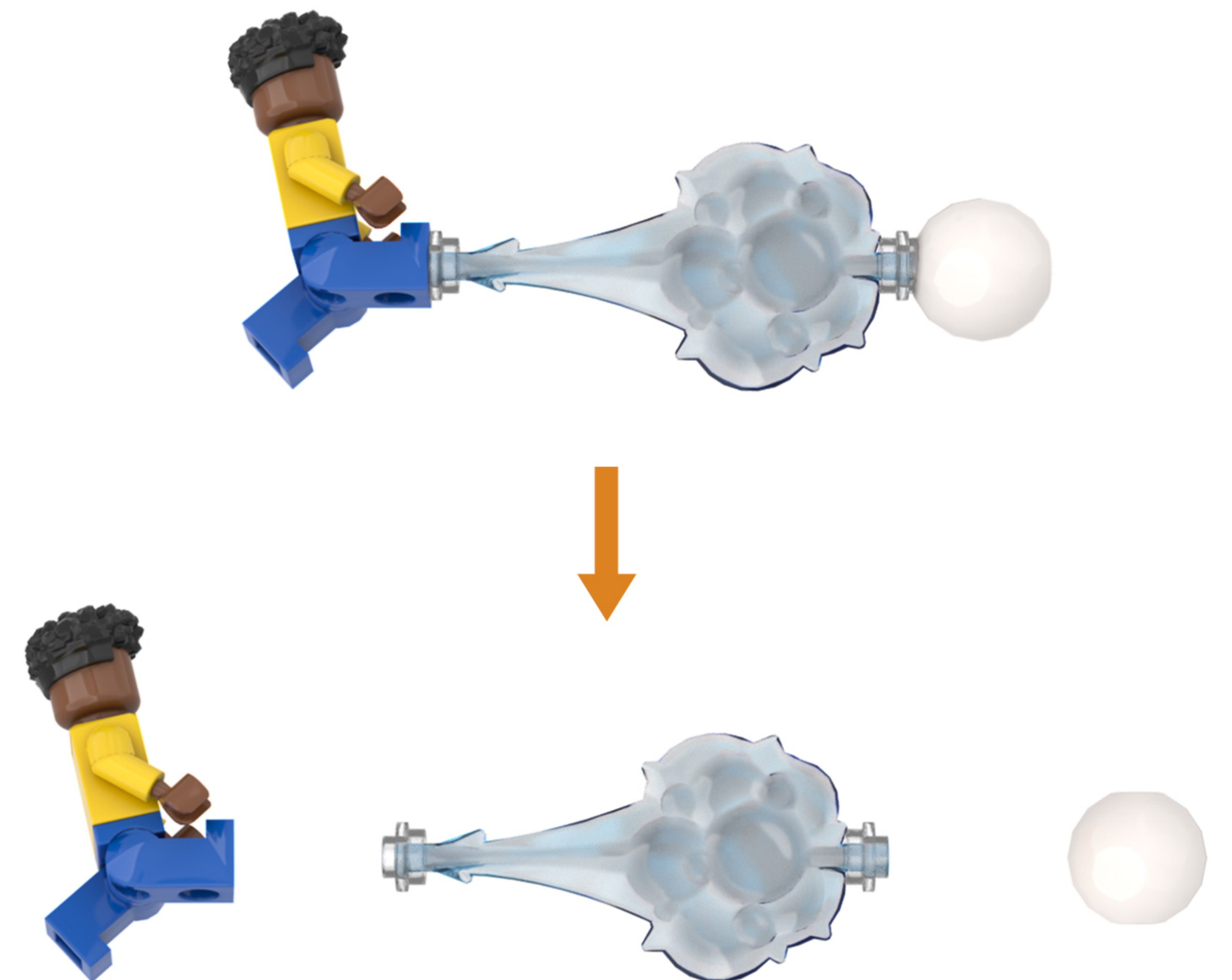
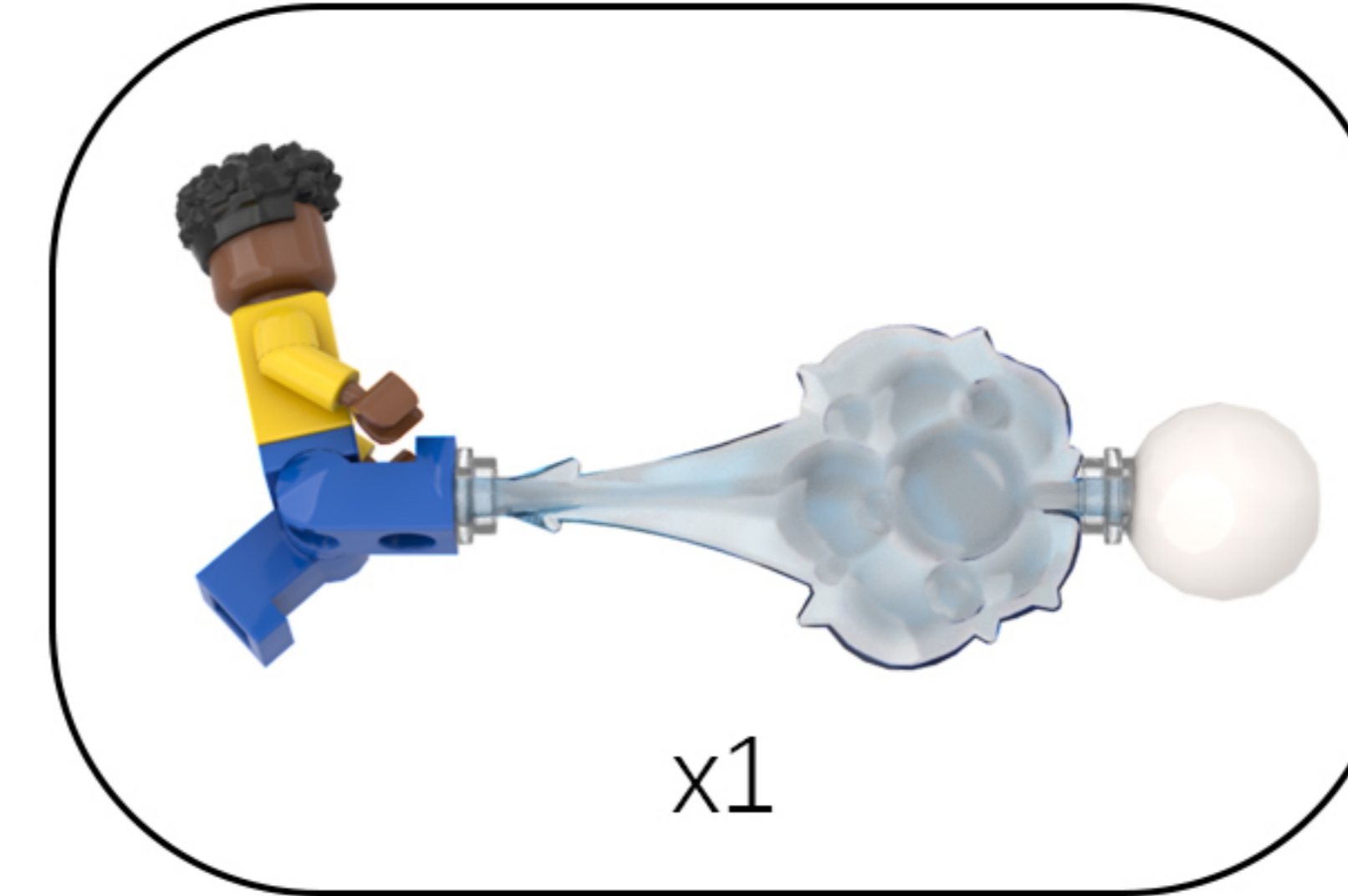

55

EN: Take out the disassembled building blocks and attach the lights from the string one by one to the blocks.

DE: Nimm die zerlegten Bausteine heraus und befestige die Lichter der Lichterkette nacheinander an den Bausteinen.

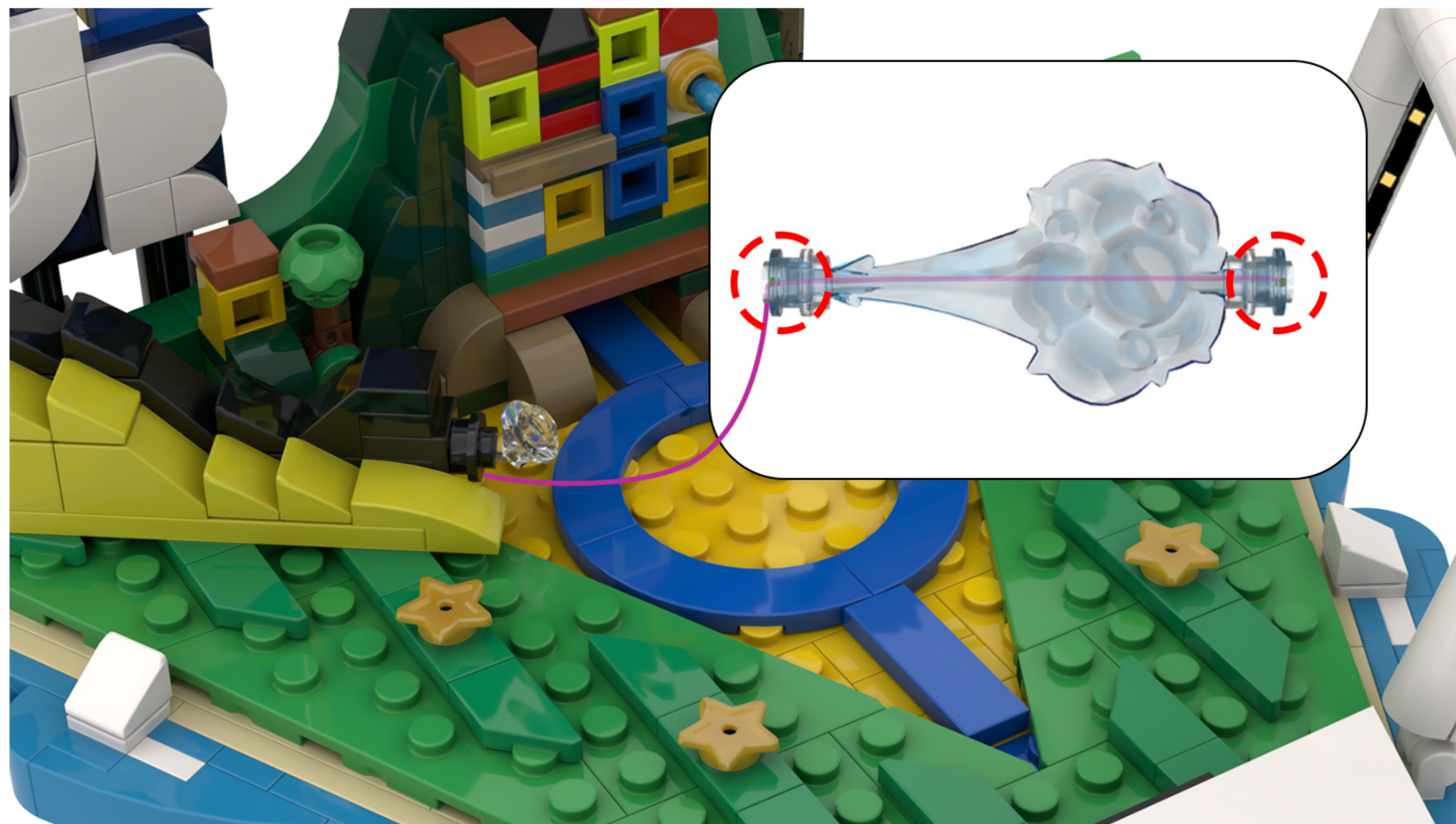
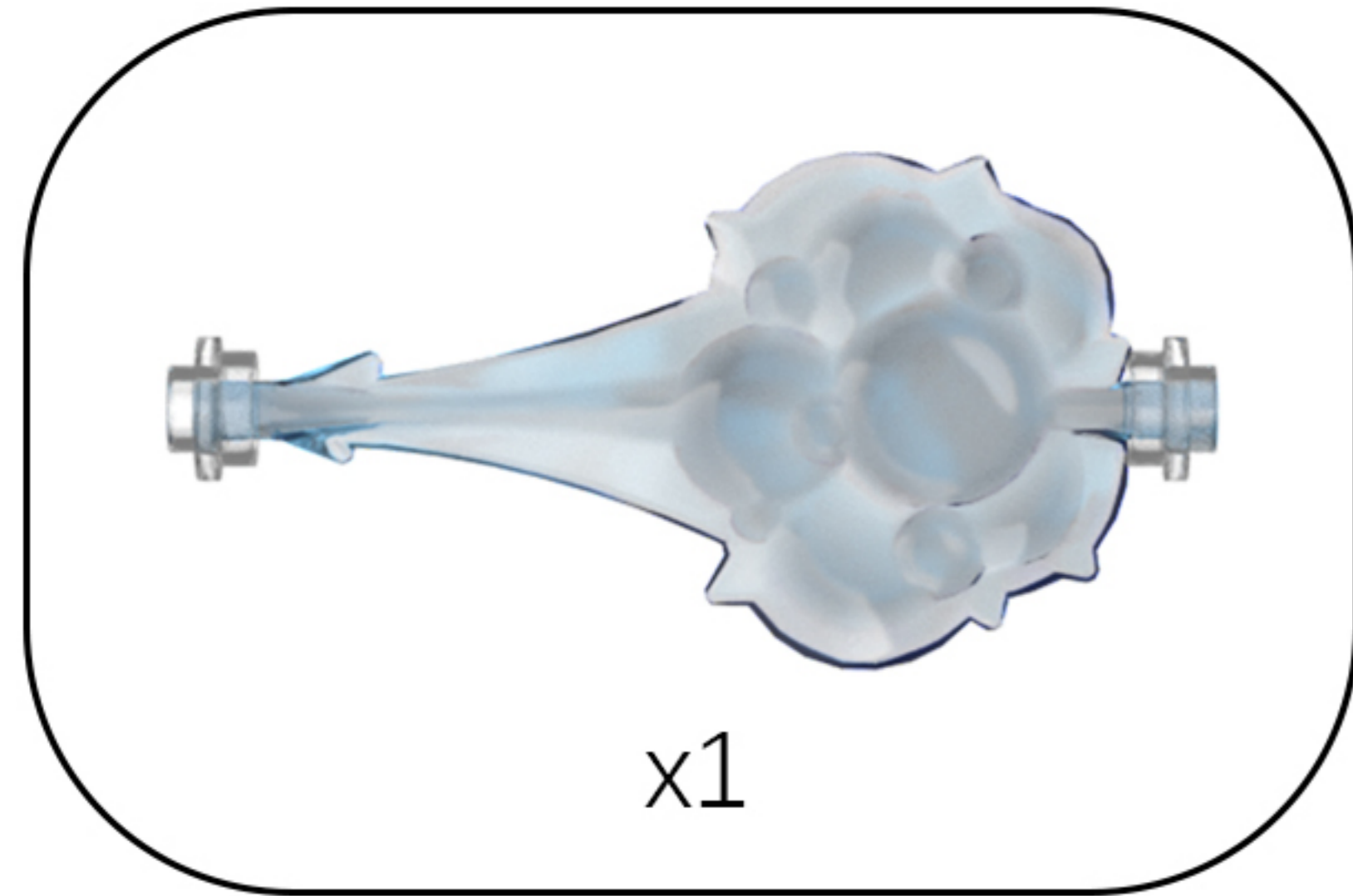

56

EN: Take out the disassembled building blocks and reassemble them.

DE: Nehmen Sie die zerlegten Bausteine heraus und setzen Sie sie wieder zusammen.

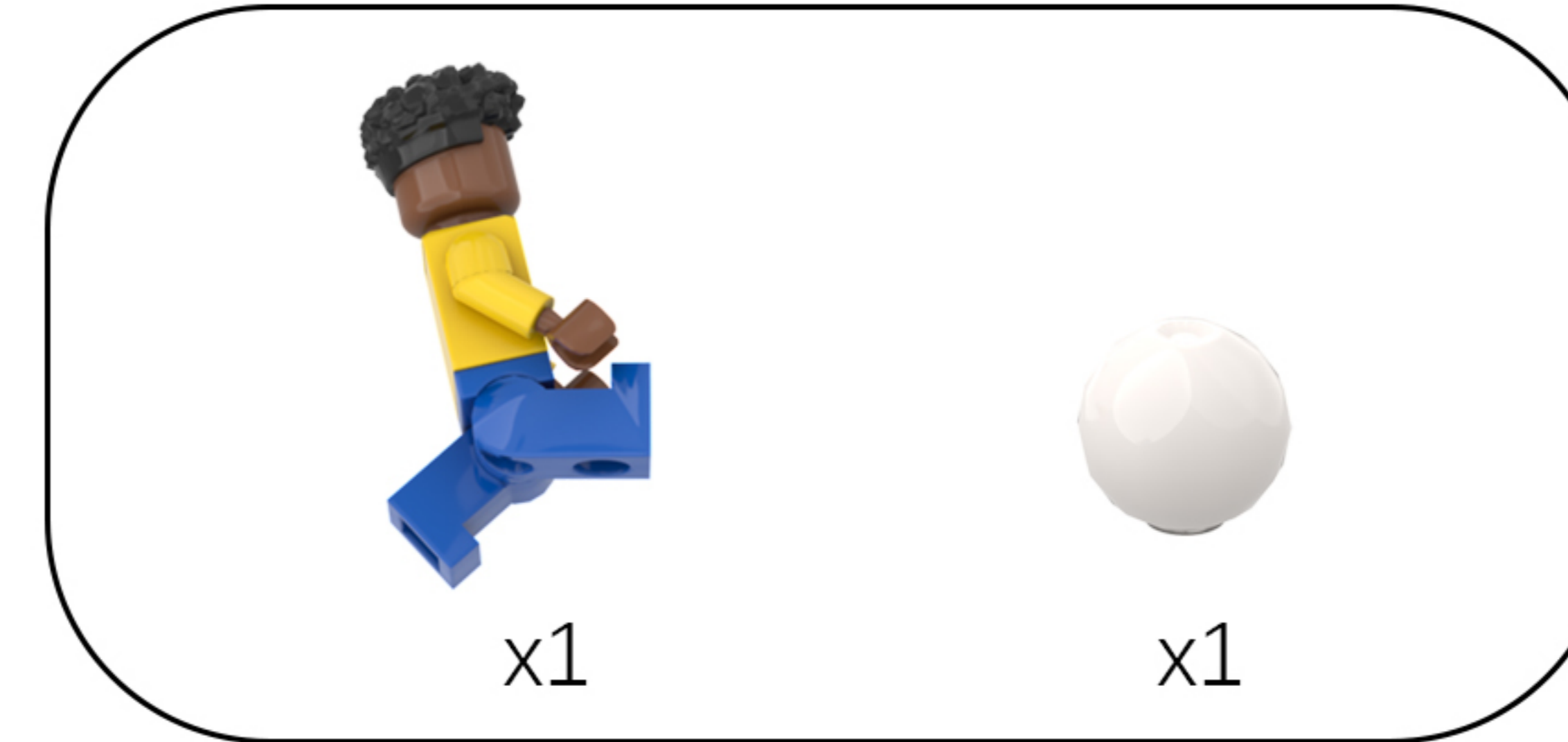

57

EN: Once installed, connect the power supply and give it a try!

DE: Die Installation ist abgeschlossen. Schließen Sie das Gerät an die Stromversorgung an und probieren Sie es aus!





Above our designers to provide the relevant ideas and instructions. But please move to the following:

- 1: about our company this product parts material, product quality do you have comments and suggestions?
- 2: about this product installation instructions and installation of the degree of difficulty do you have views and suggestions?
- 3: if in the operation of the product we provide ideas encountered any problems, please contact us in a timely manner.

Tips

If you encounter any installation problems please contact the seller, we will be happy to help you solve!