

# INSTALLATION GUIDE

75460 New Republic  
X-wing Starfighter  
Remote-controlled model



LED light kit compatible with Lego

# Instructions for installing this kit:

This set includes 6 pouches. (The battery case functions similarly; please select your own power source. This article uses a USB power cable.)

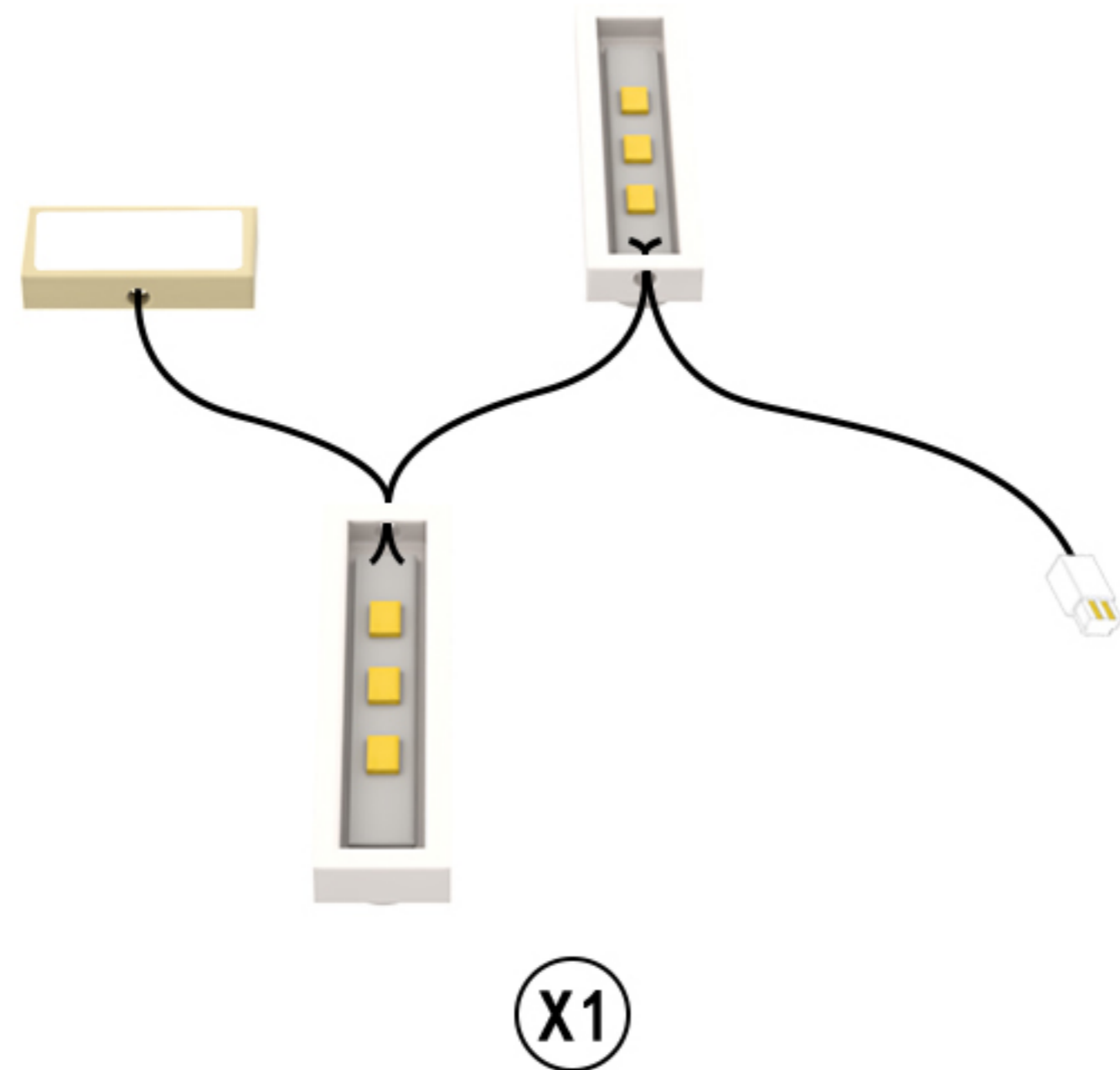
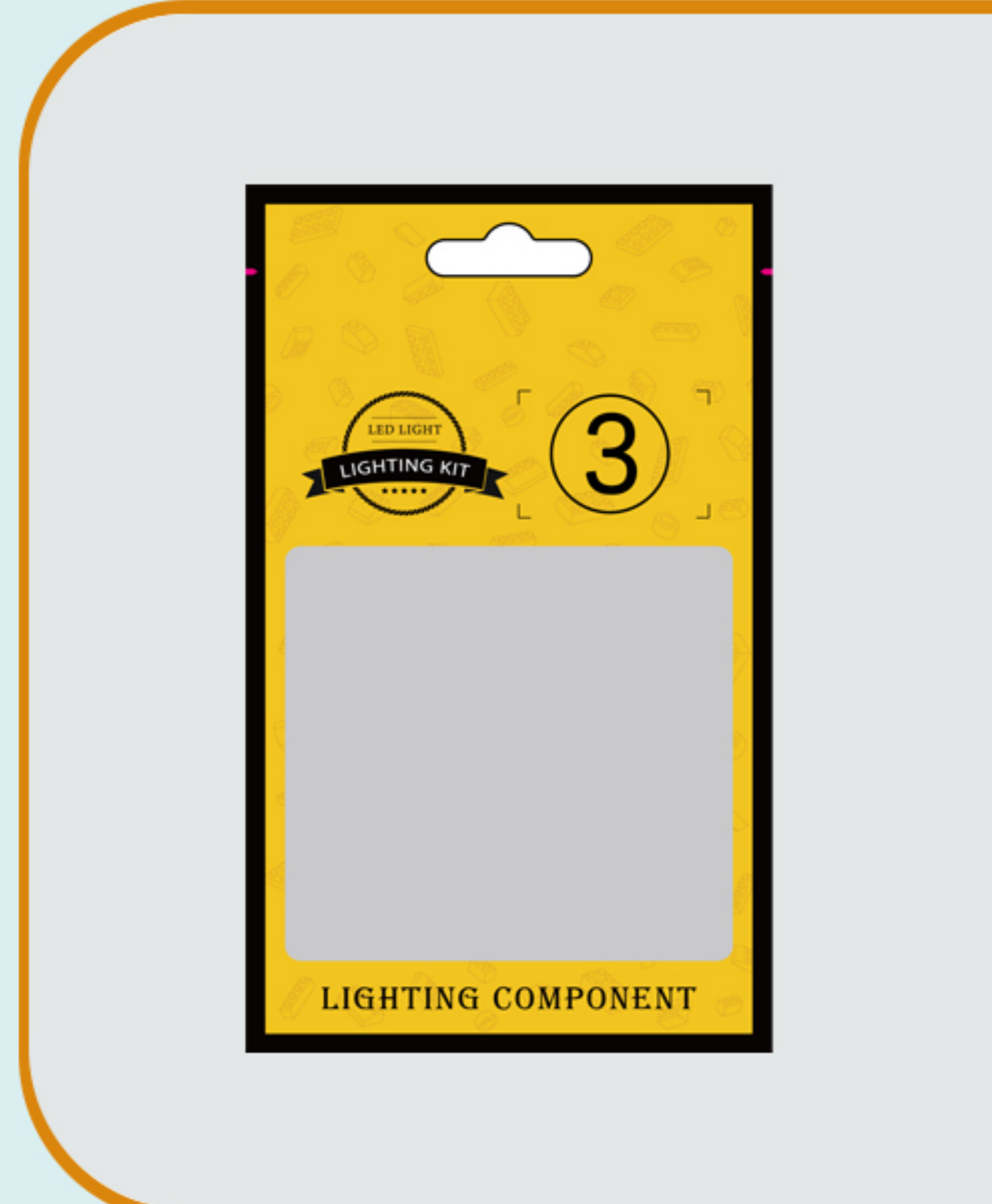
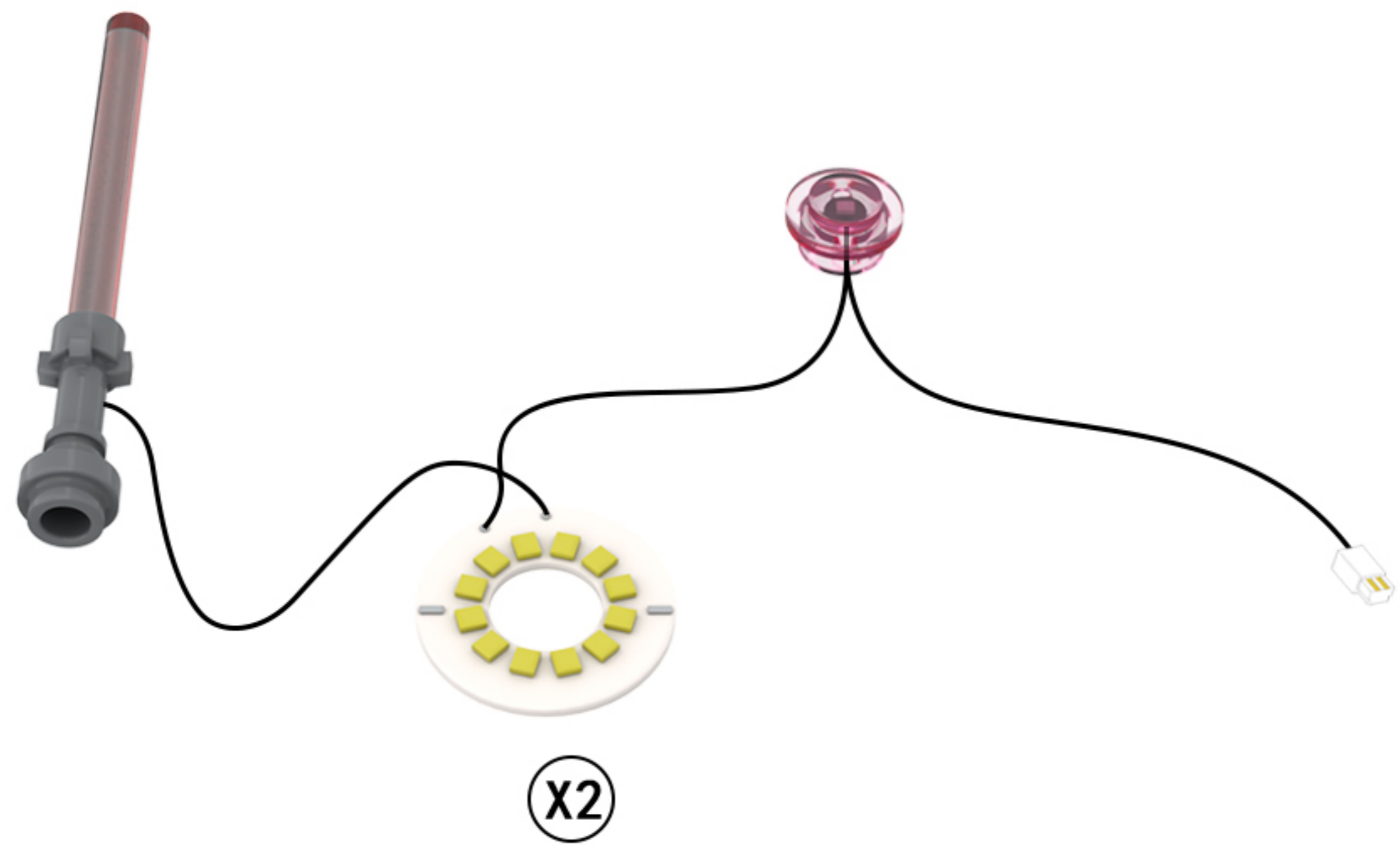
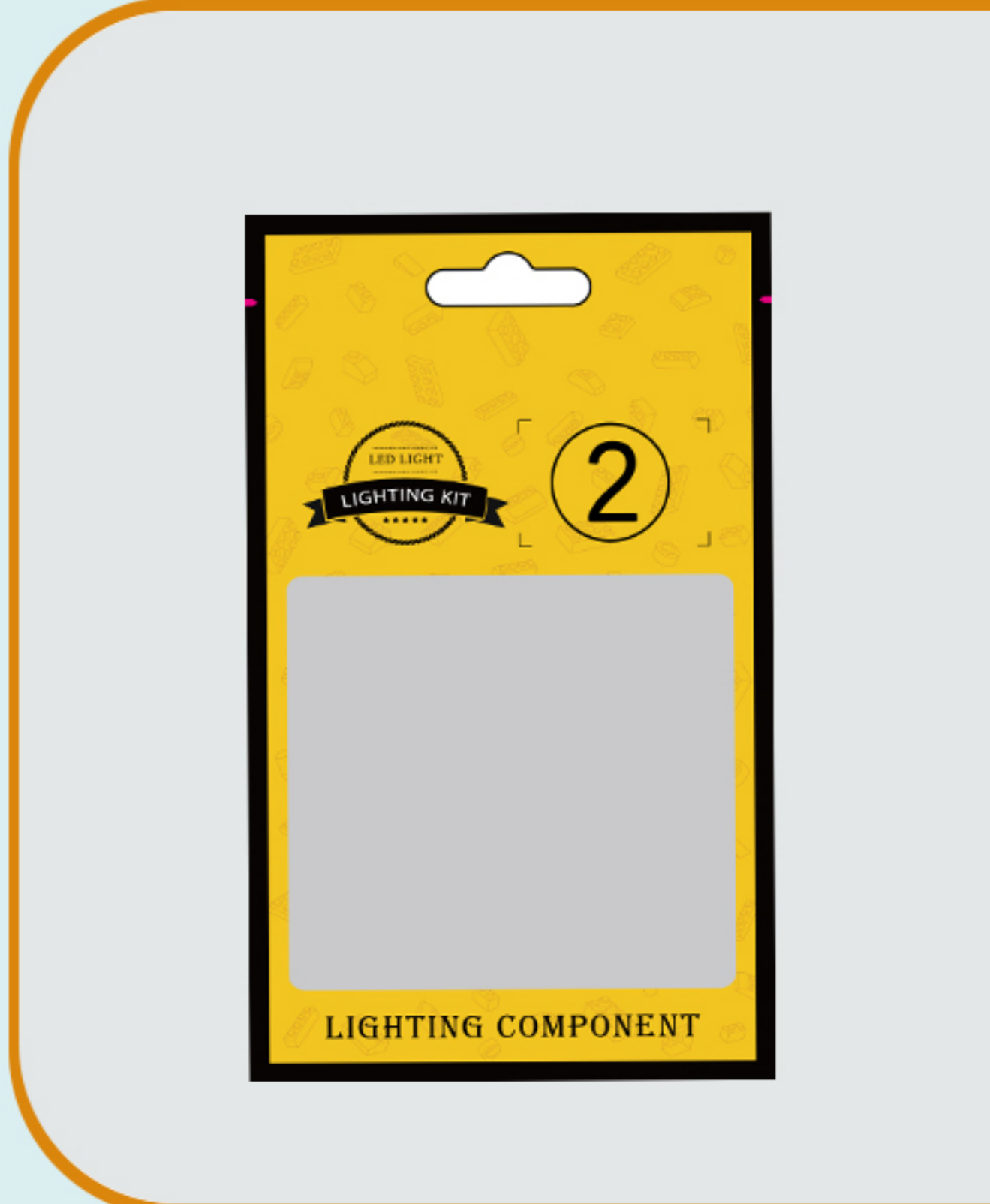
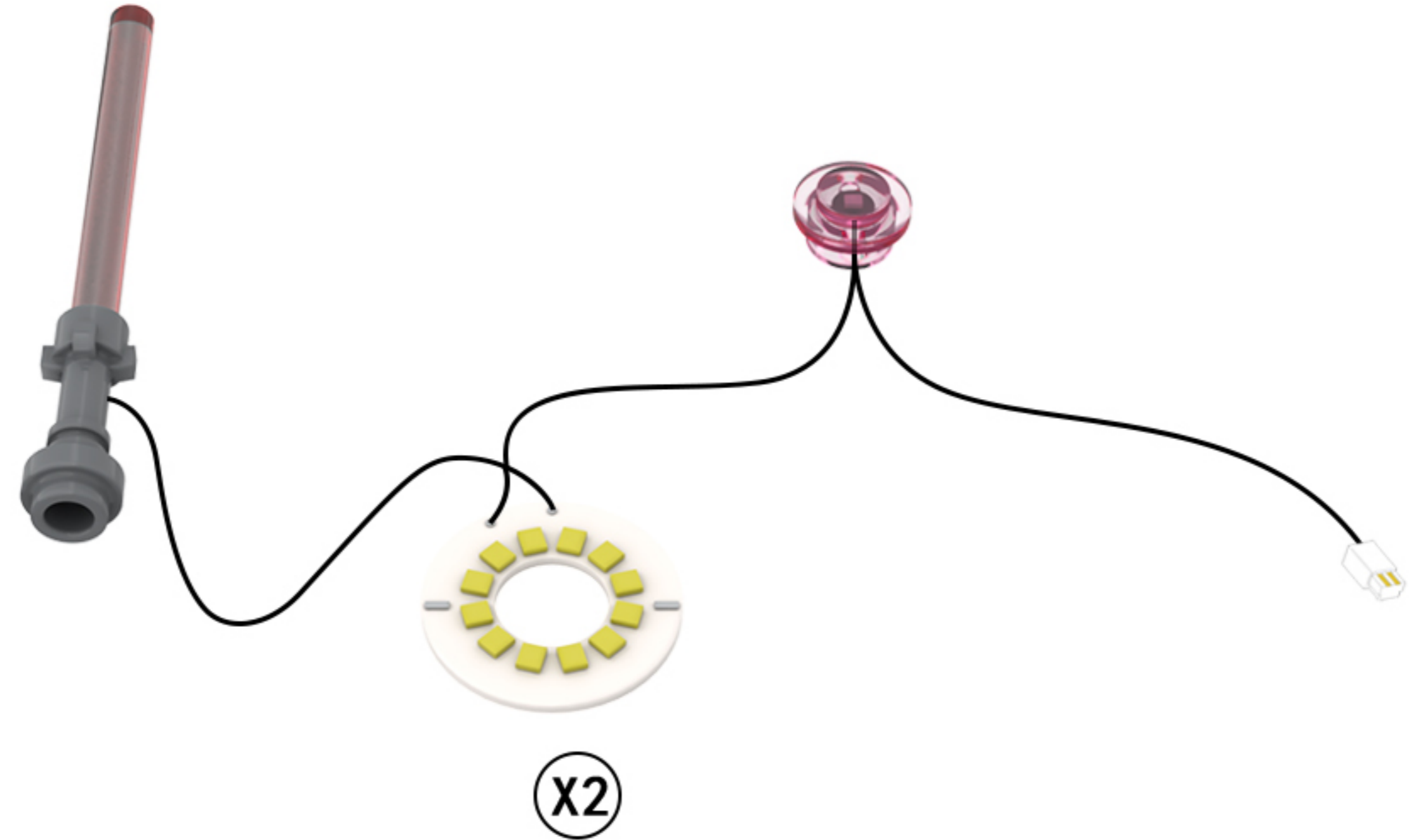
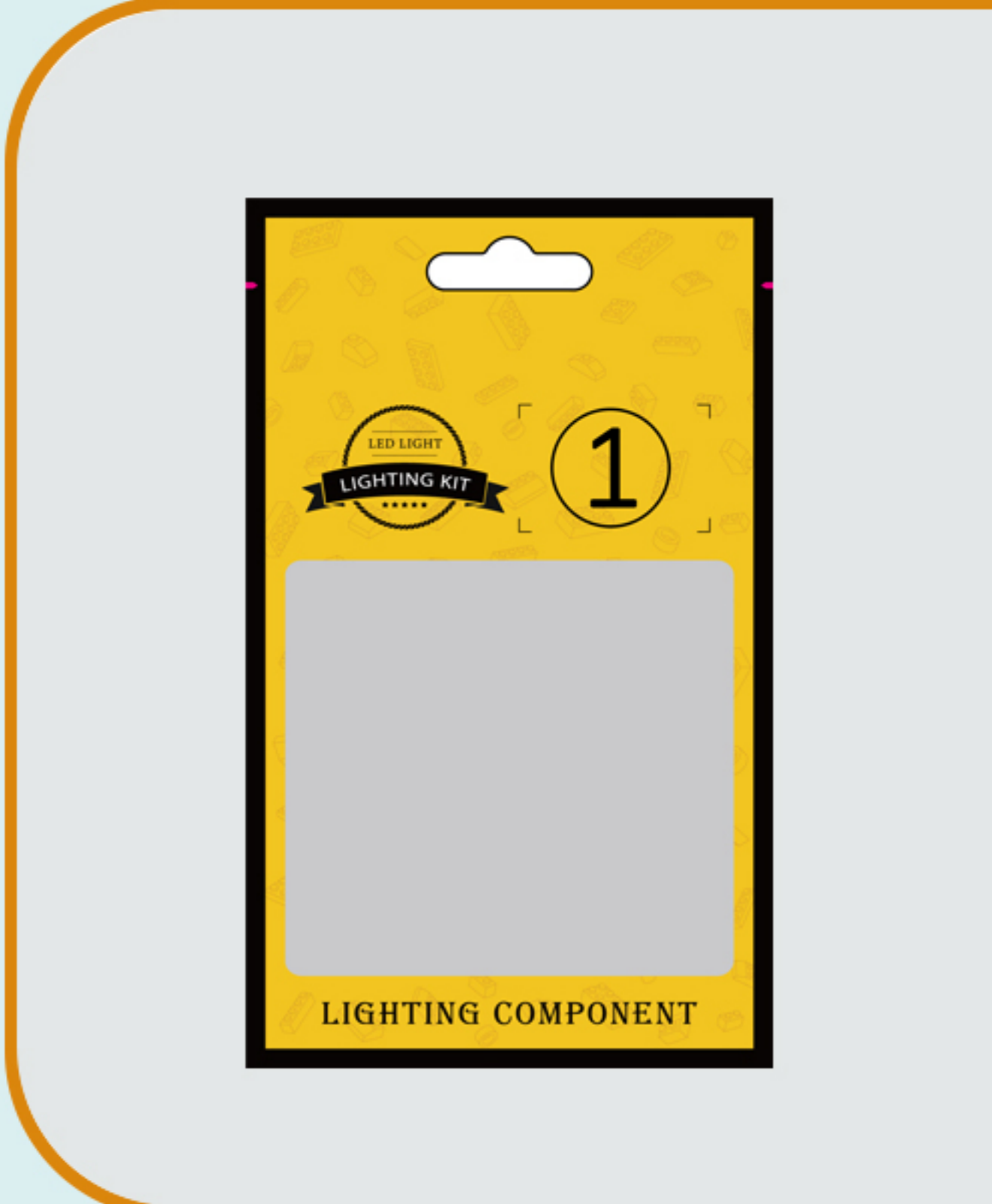

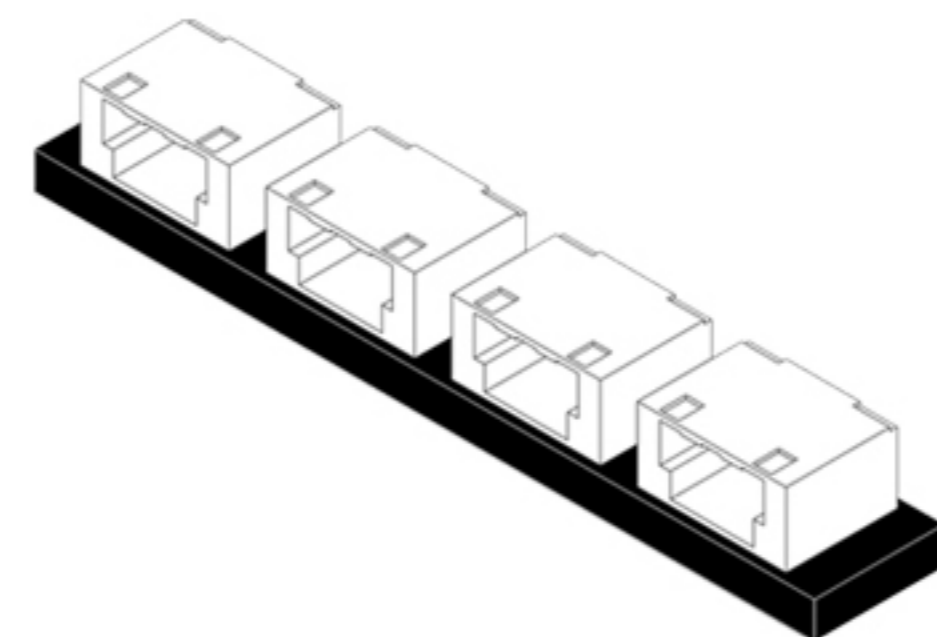

X1

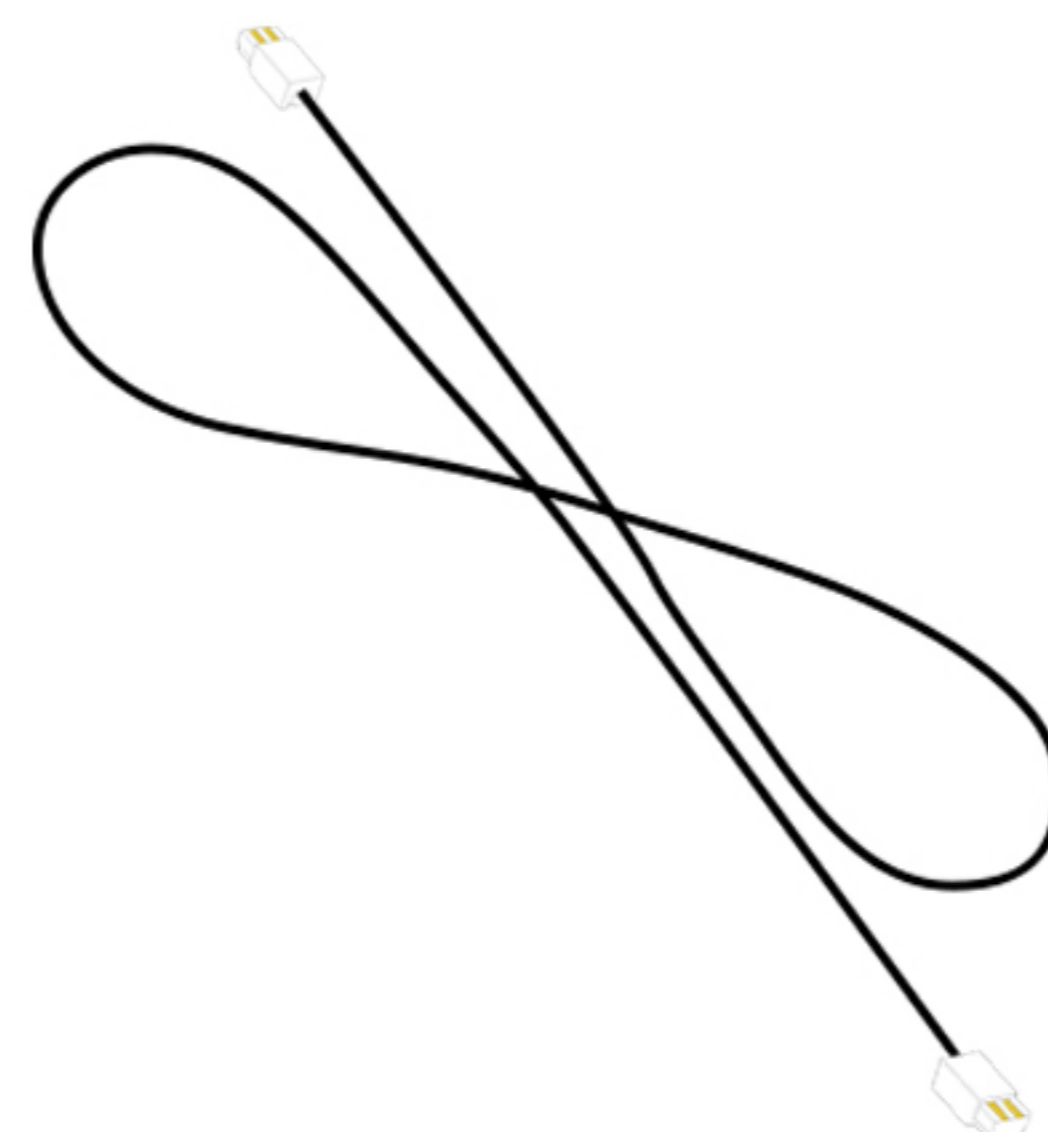

5cm

X1

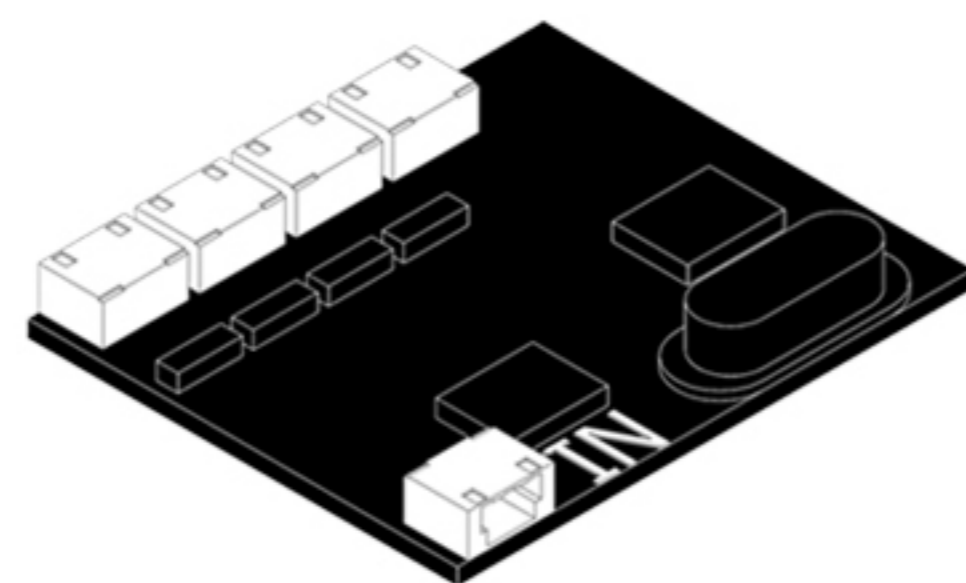

X1

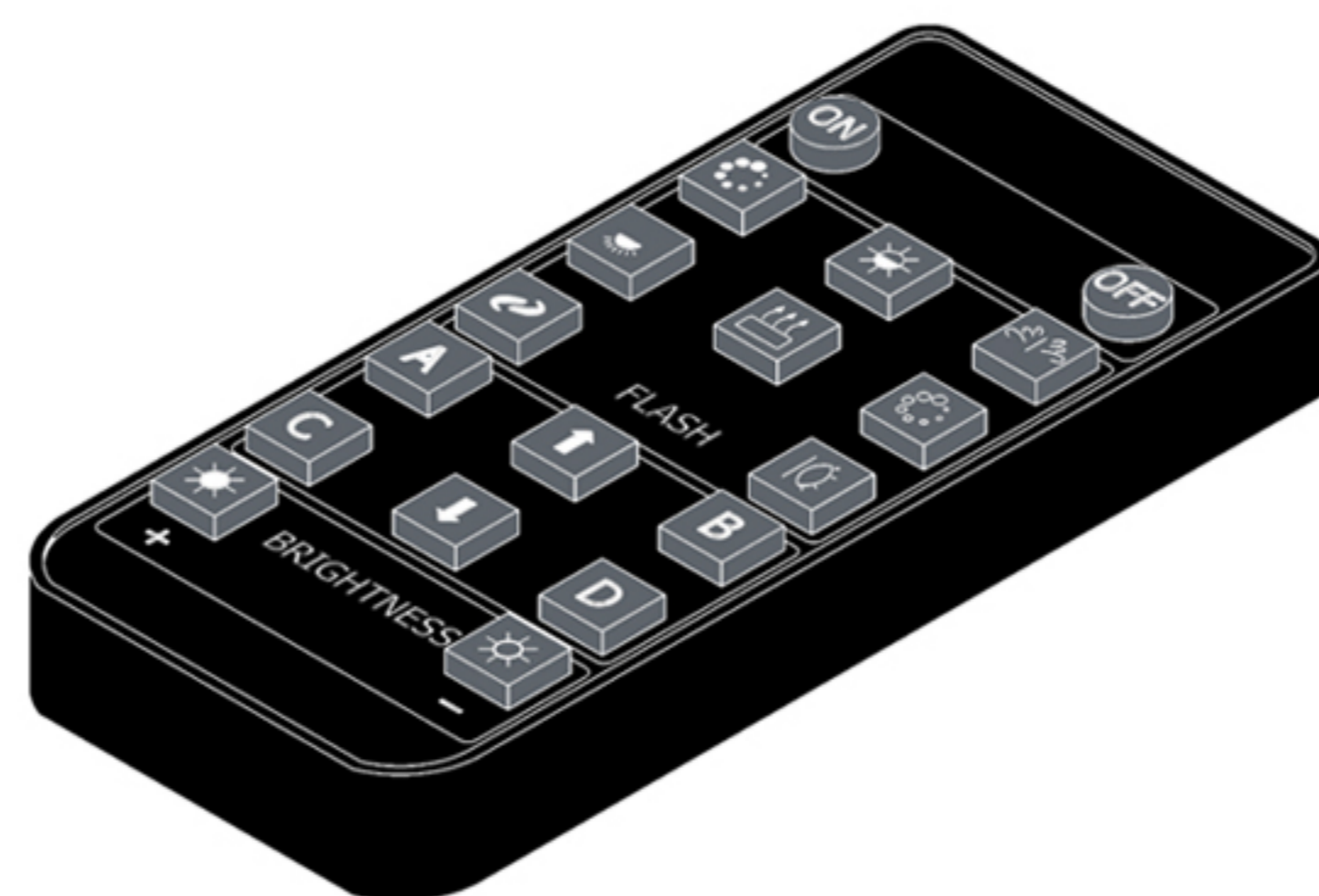

X1

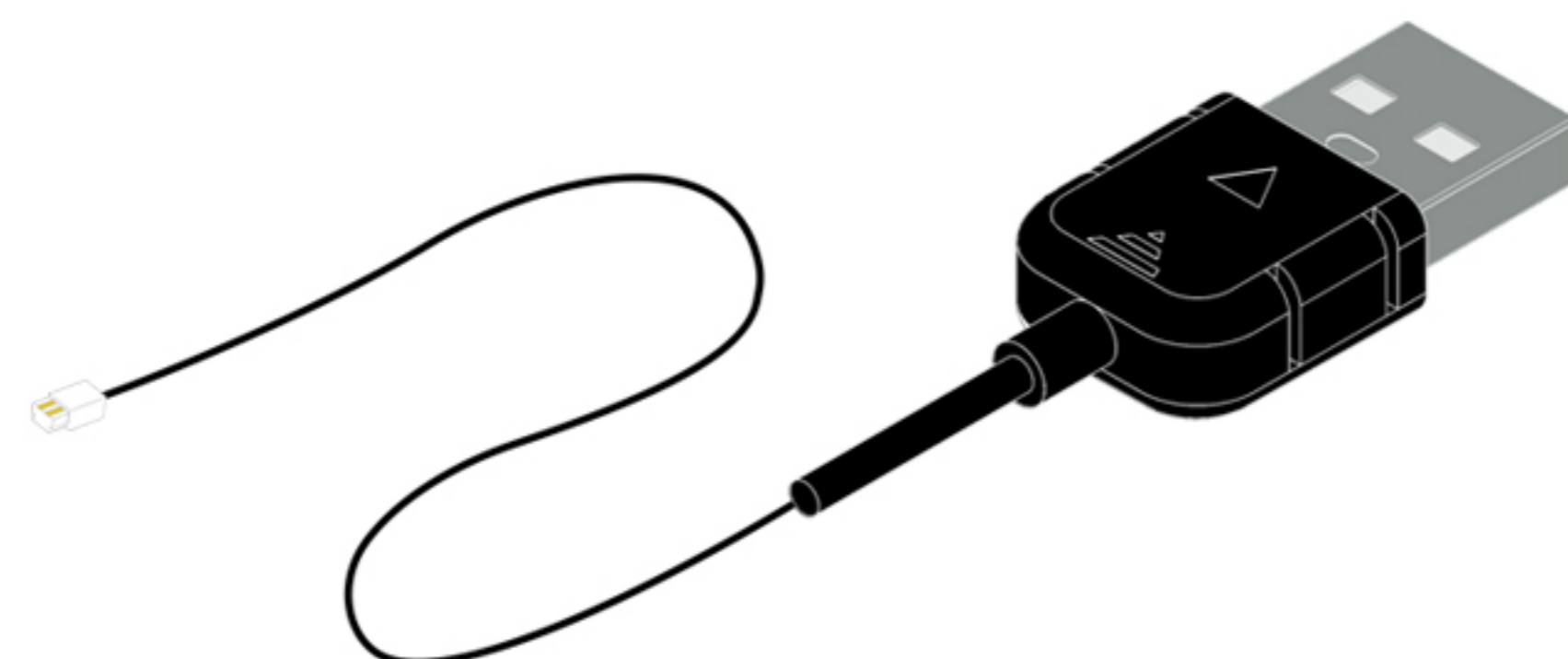
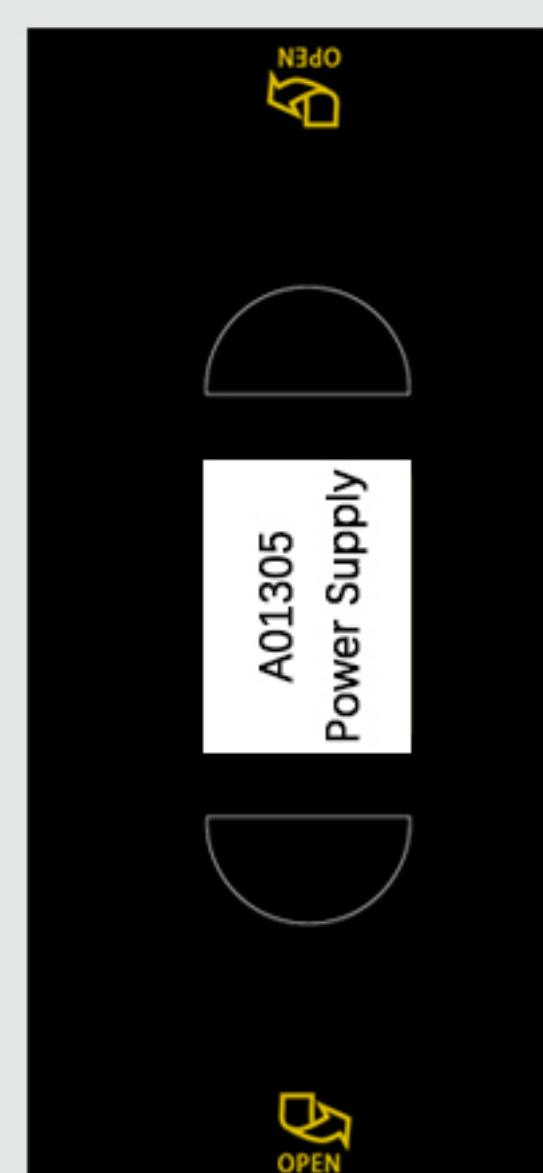

X1

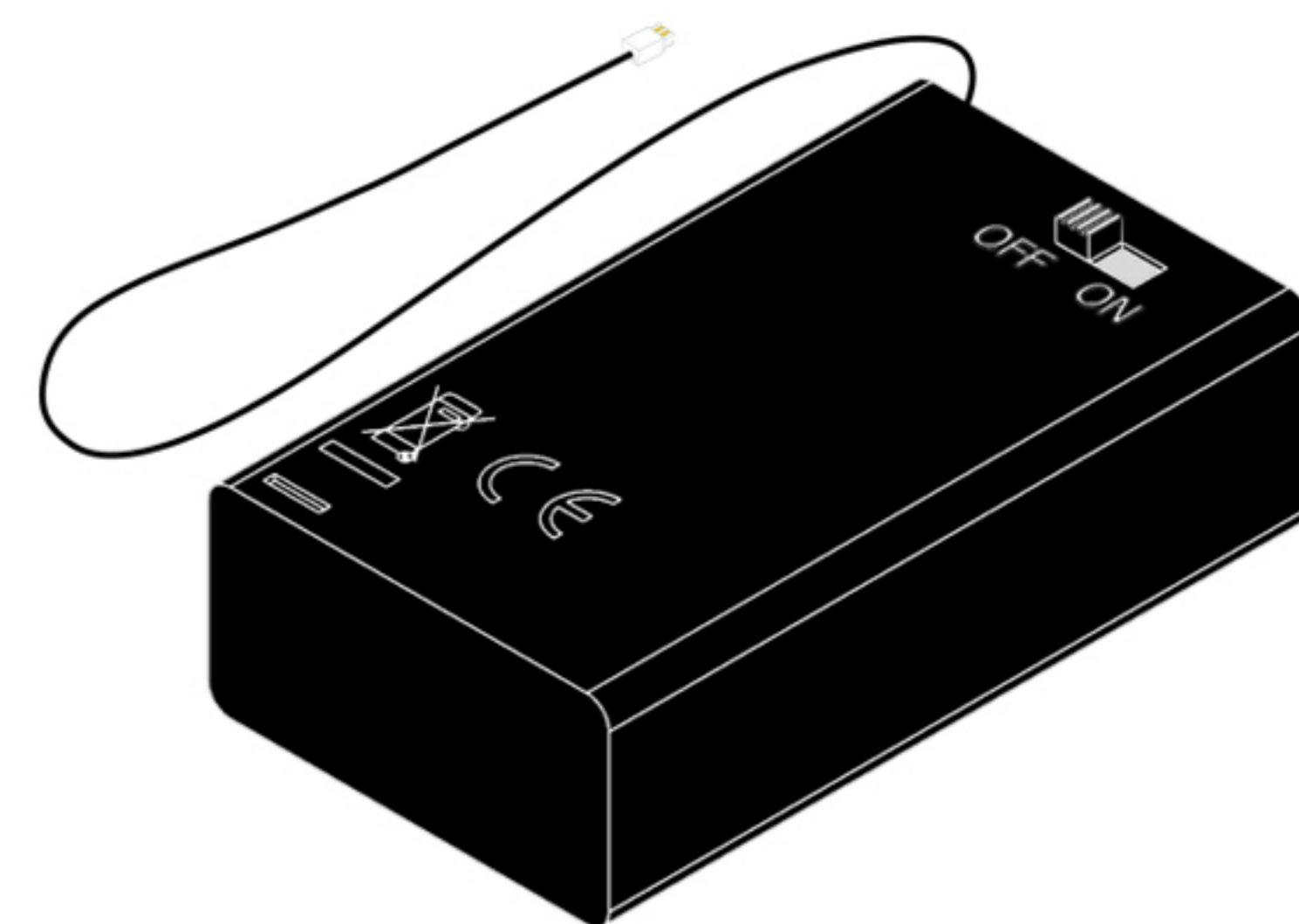

X1

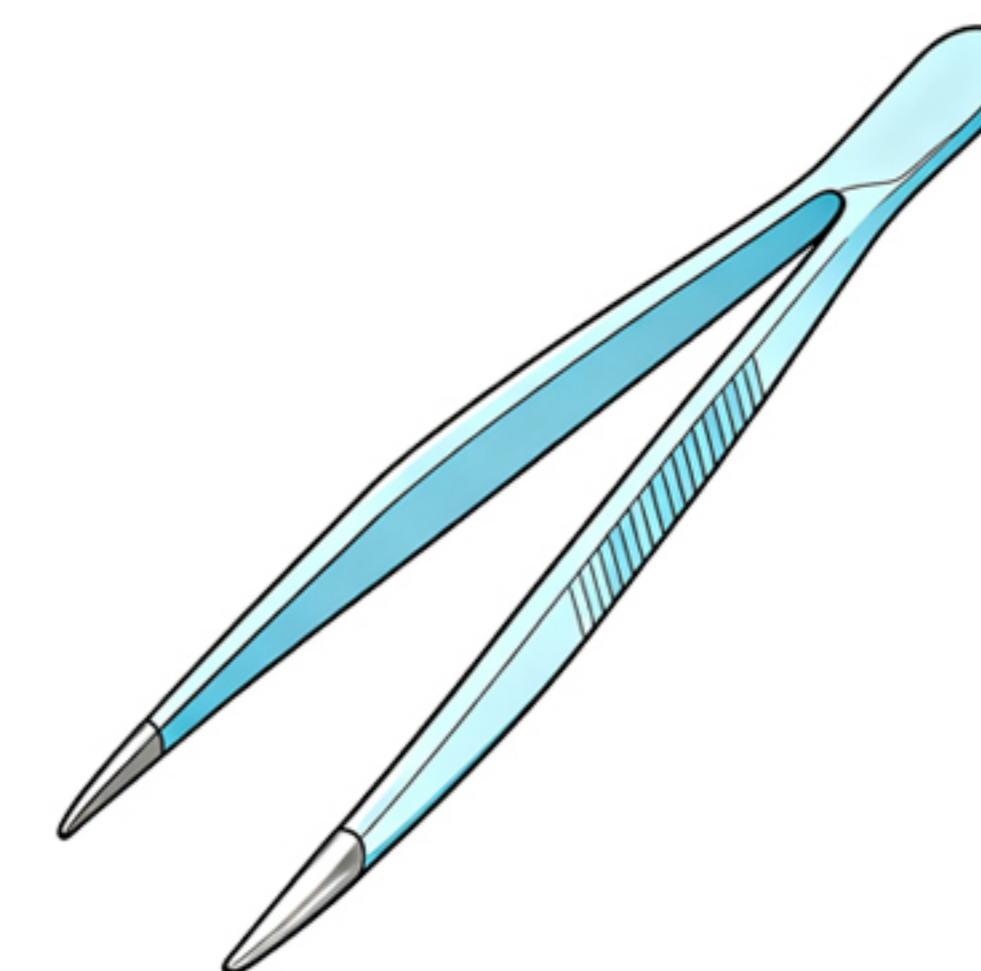

X1

This post will complete the light installation in two main sections.

Step 1-test



Step 2-mounting

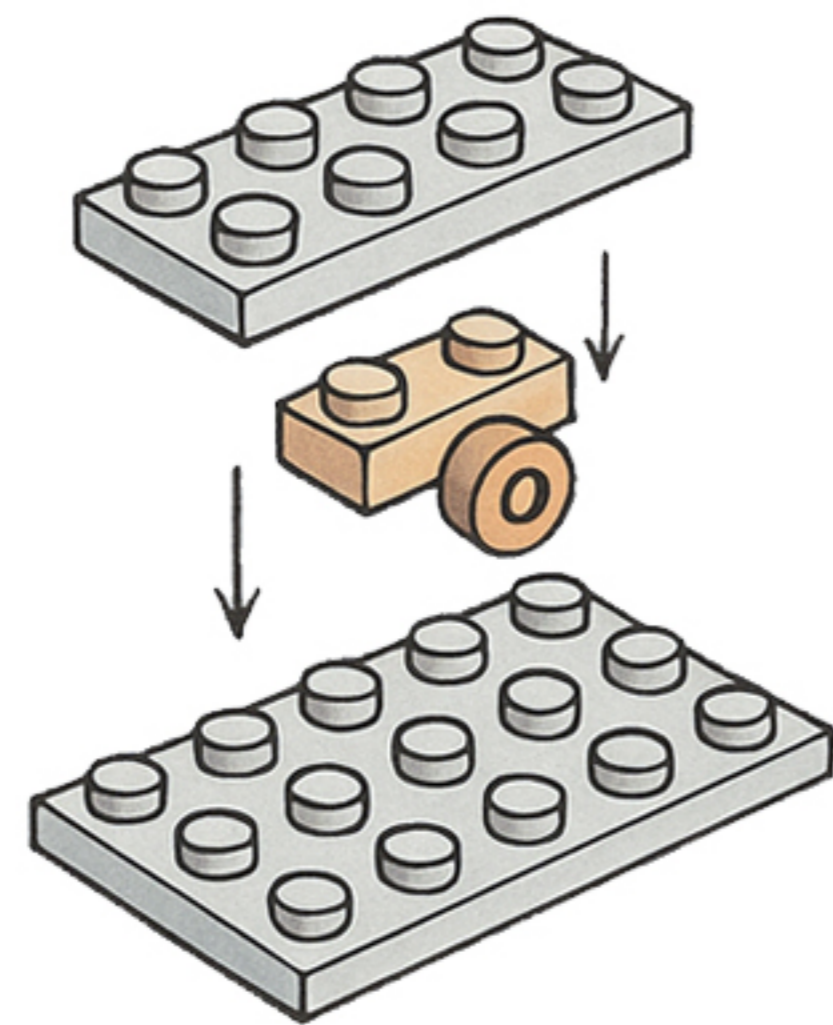

So let's get started!

## Step 1-Test.

- 1** EN: Remove the expansion board from Bag 4.  
DE: Entnehmen Sie die Erweiterungskarte aus Beutel 4.

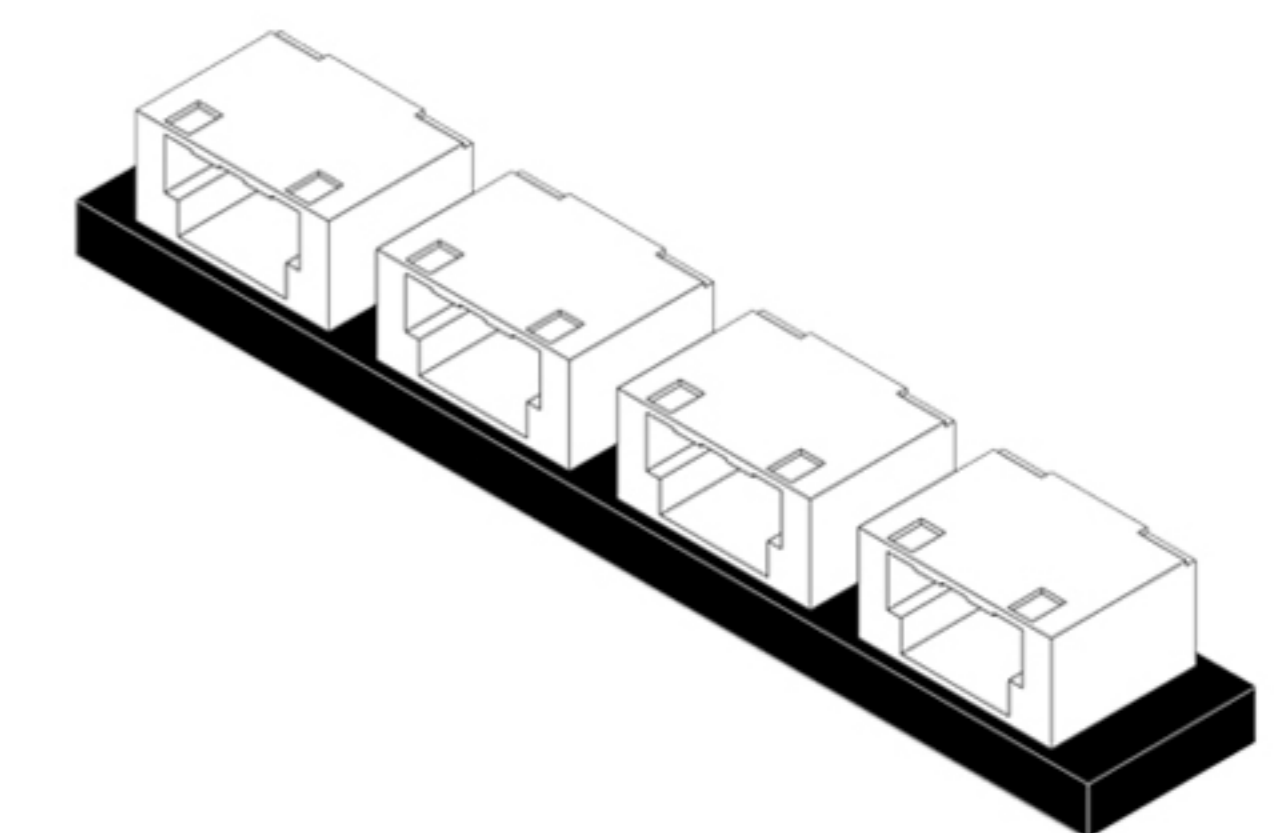

x1

2

EN: Take the USB power cable out of the box and connect it to the expansion board.

DE: Nehmen Sie das USB-Stromkabel aus der Verpackung und schließen Sie es an die Erweiterungskarte an.

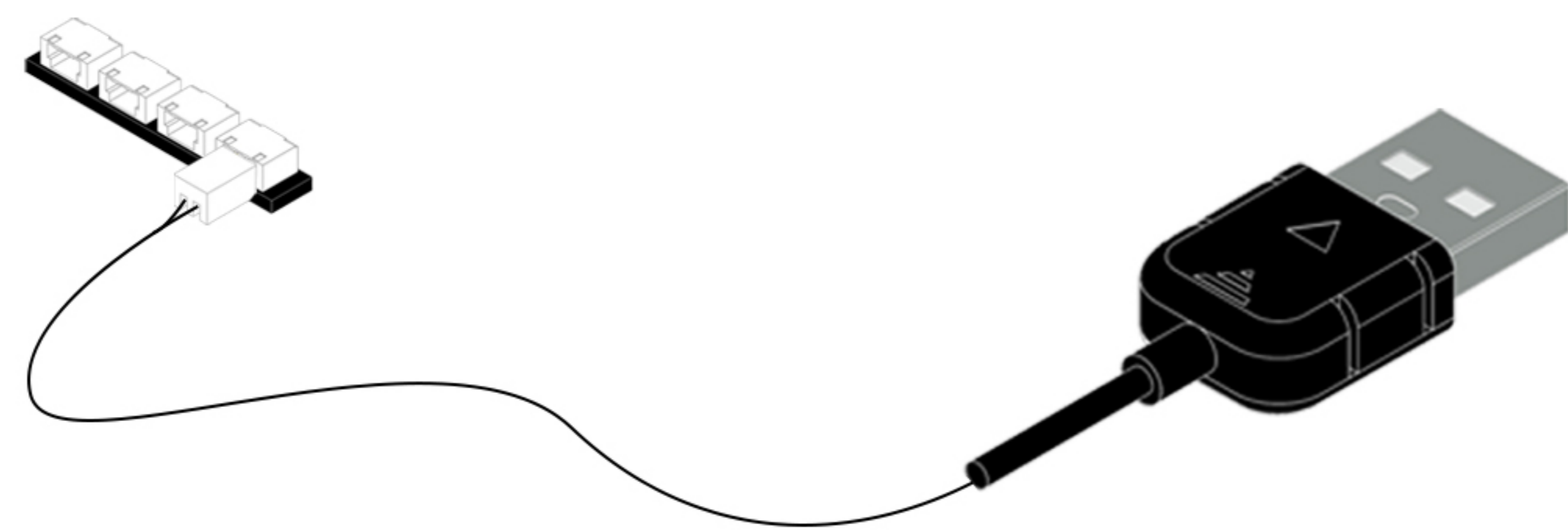
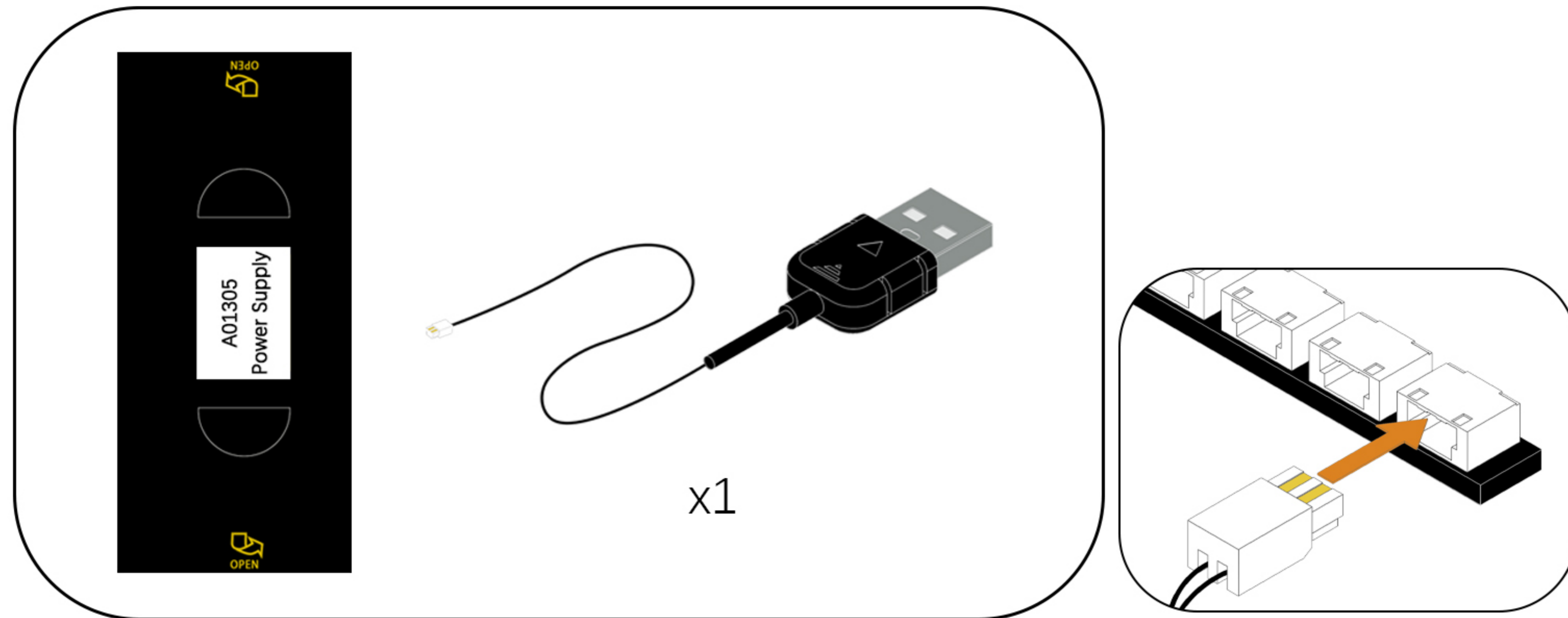

3

EN: Connect the USB power cable to the mobile power supply. (Power supply not included; see the diagram below for power supply options.)

DE: Schließen Sie das USB-Netz-kabel an die mobile Stromversorgung an. (Stromversorgung nicht im Lieferumfang enthalten, siehe Abbildung unten für die Stromversorgungsart.)

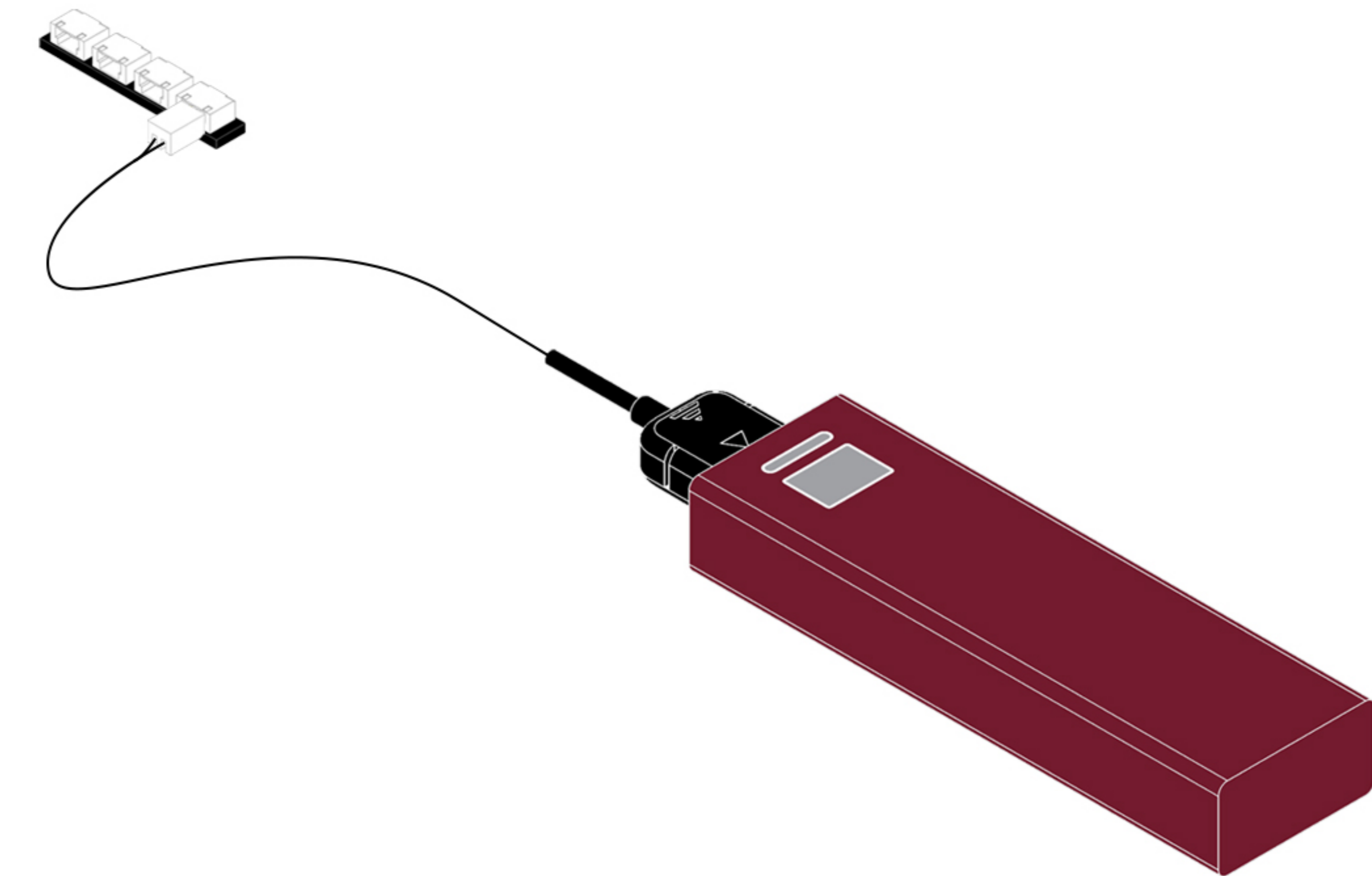

### USB Connectors to Connect Devices

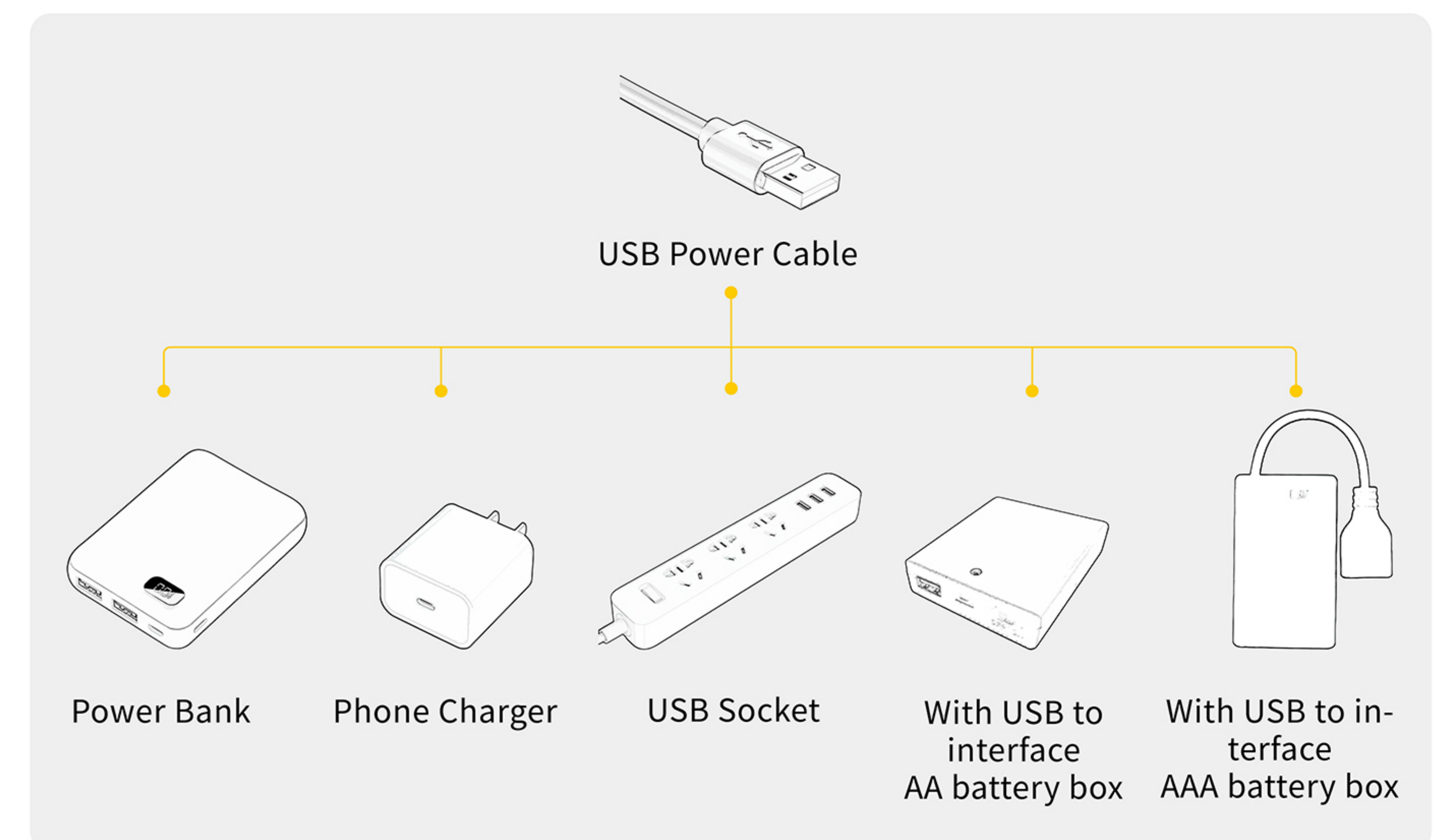

4

EN: Remove the string of lights from Bag 1, connect it to the expansion board, turn on the power, and check that the lights are working properly. If you notice any issues, please contact us immediately.

DE: Nehmen Sie die Lichterkette aus Beutel 1, schließen Sie sie an die Erweiterungskarte an, schalten Sie den Strom ein und überprüfen Sie, ob die Lichter ordnungsgemäß funktionieren. Sollten Sie Probleme feststellen, kontaktieren Sie uns bitte umgehend.

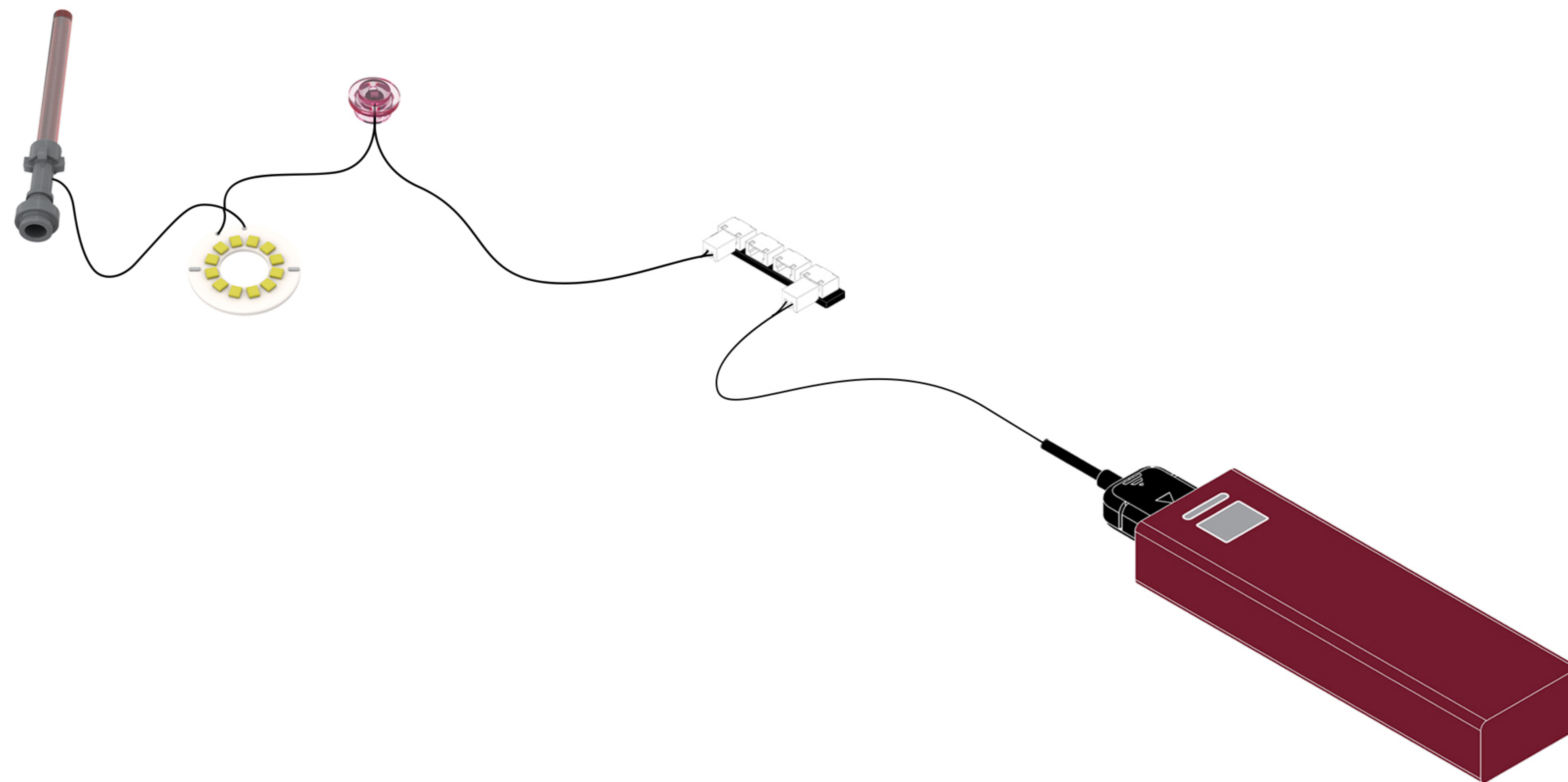
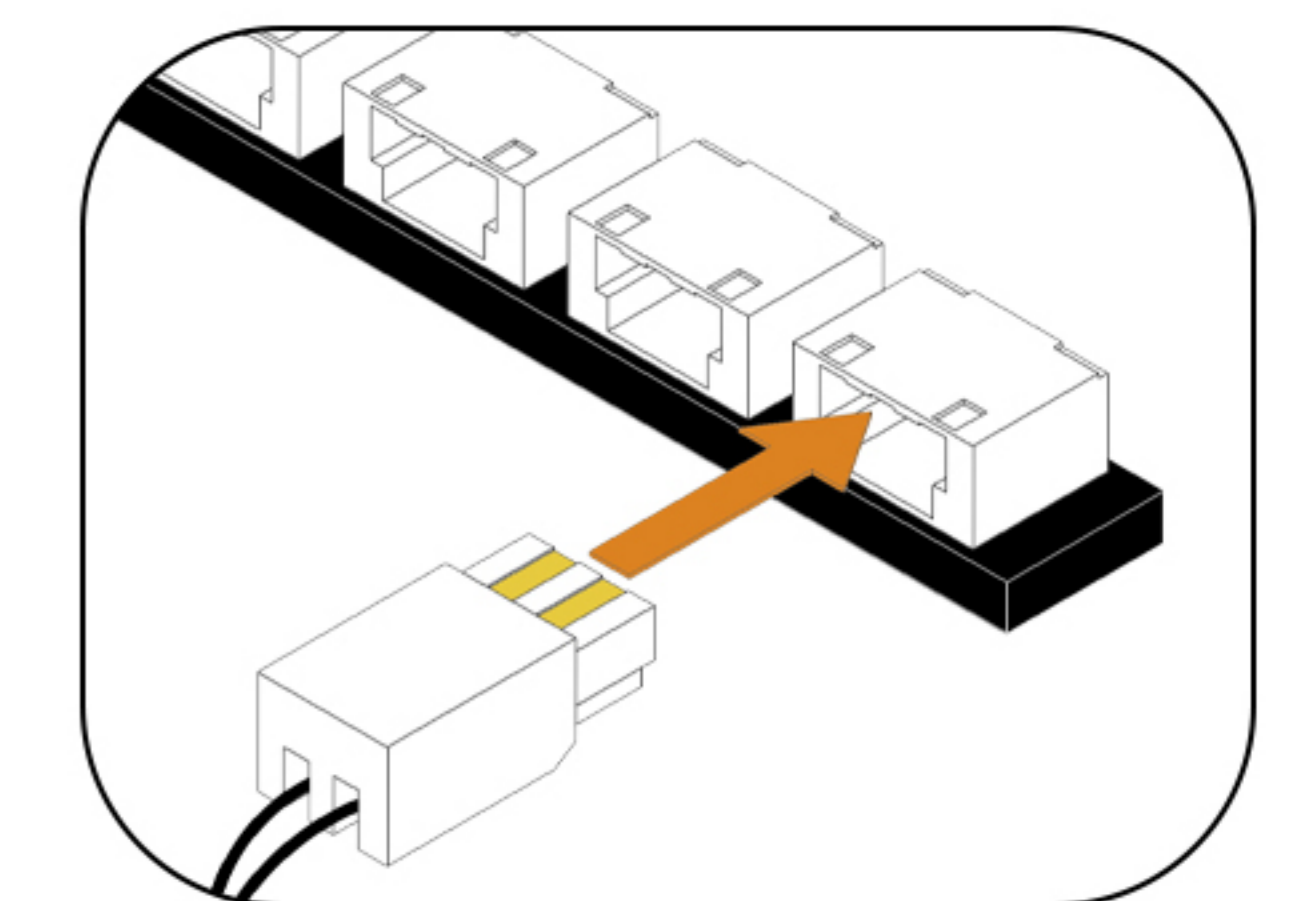
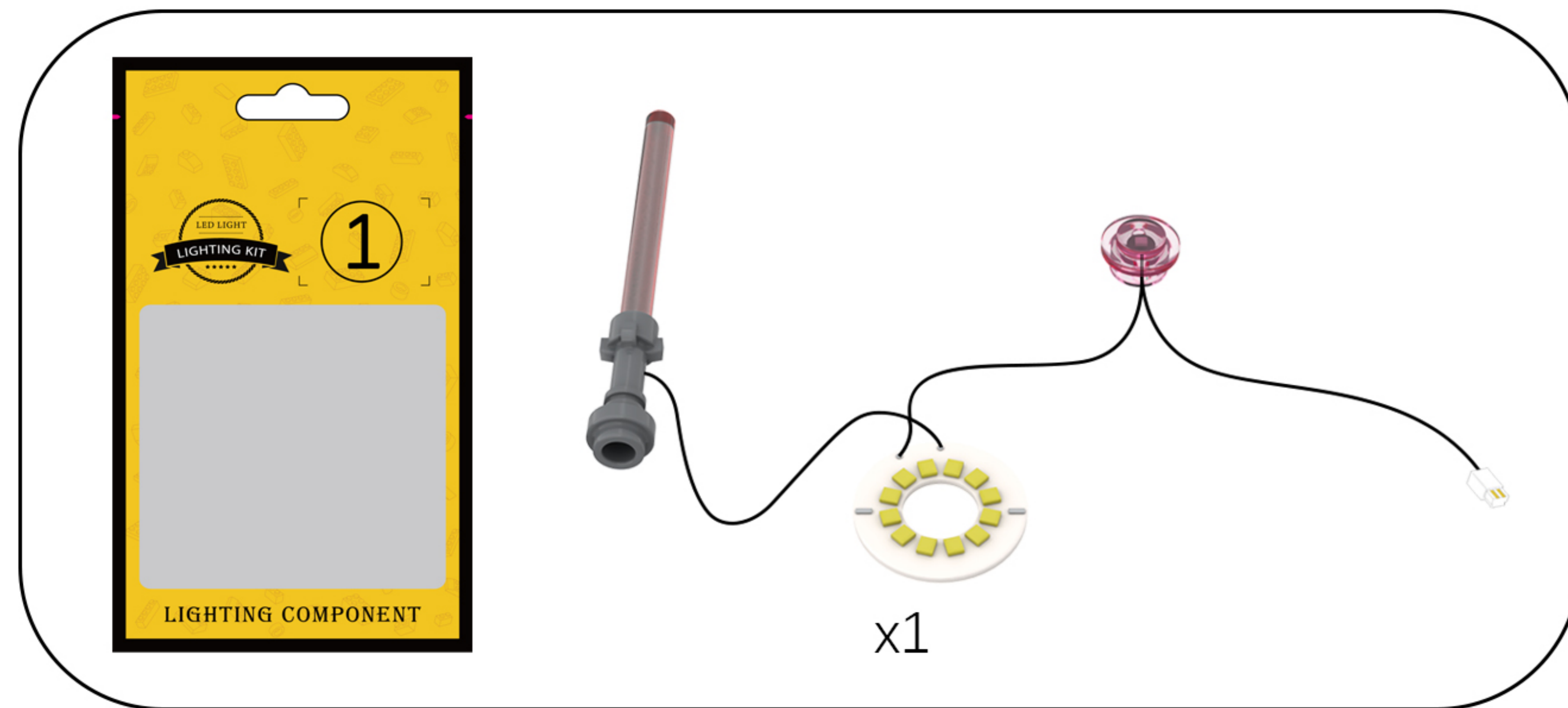

After confirming that there are no abnormalities, temporarily return each part to its original bag.

## Step 2-Mounting.

1

EN: Take out the building block model.

DE: Nimm das Bauklotzmodell heraus.



2

EN: Remove the building blocks one by one.

DE: Entfernen Sie die Bausteine nacheinander.

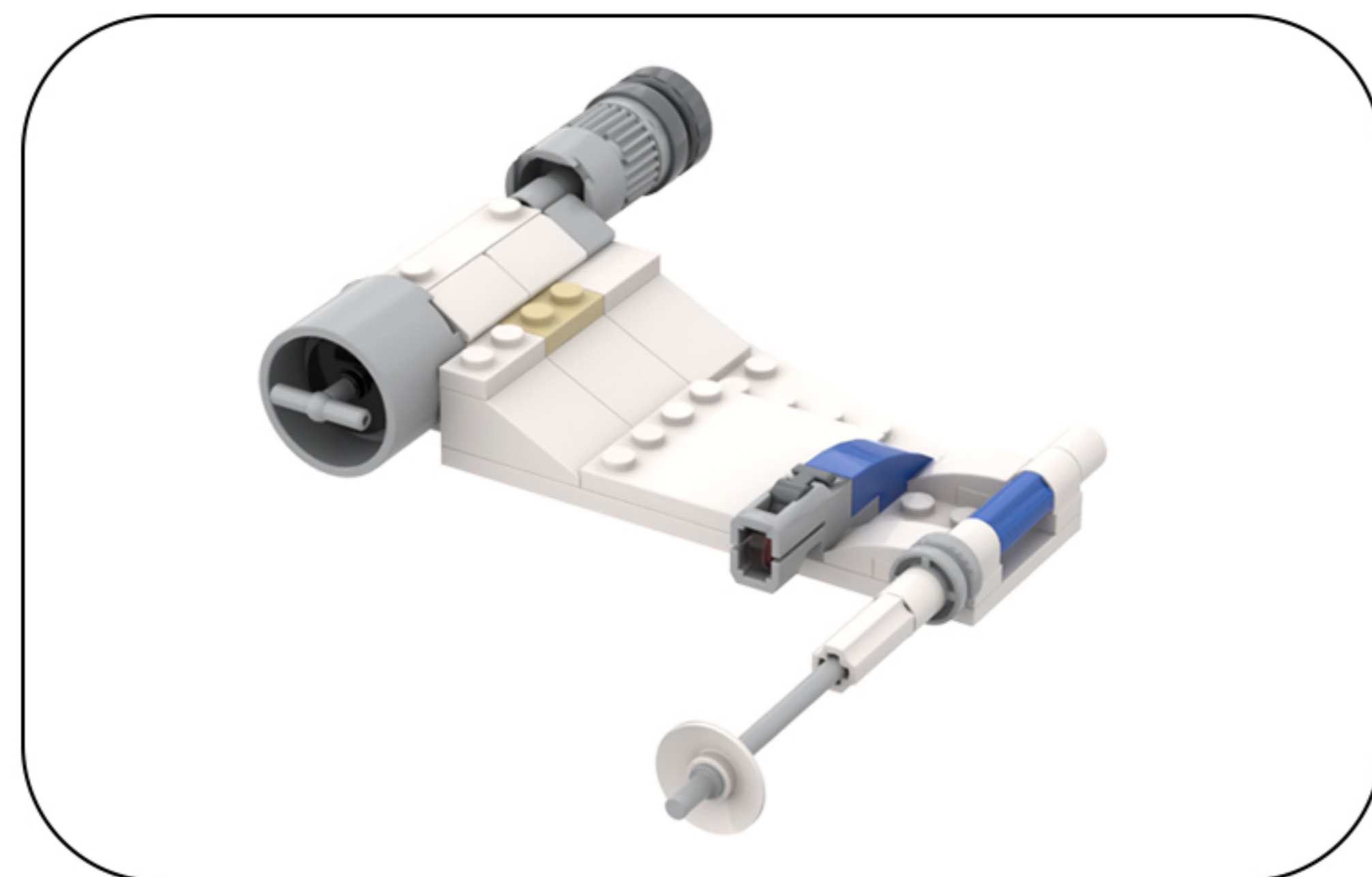
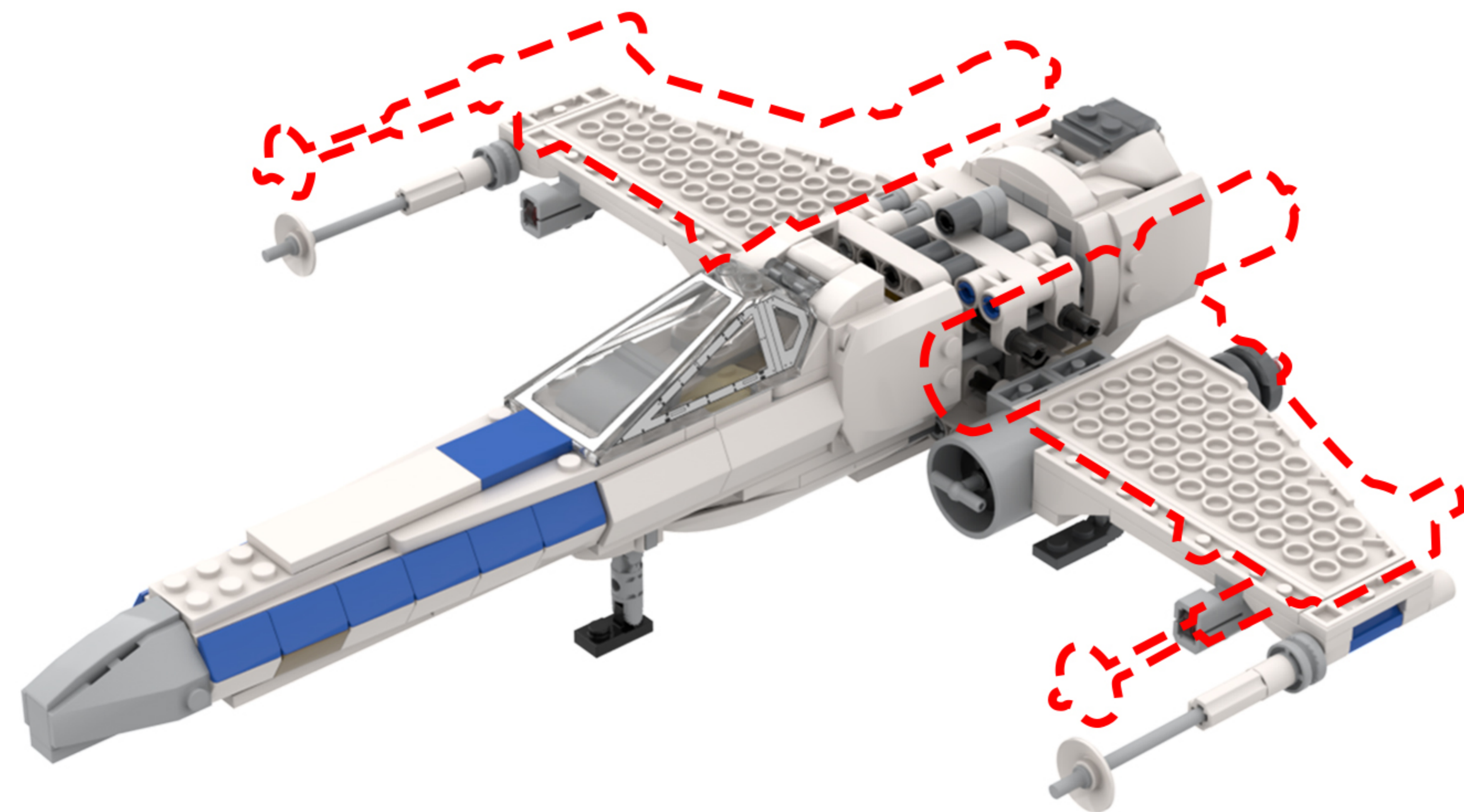
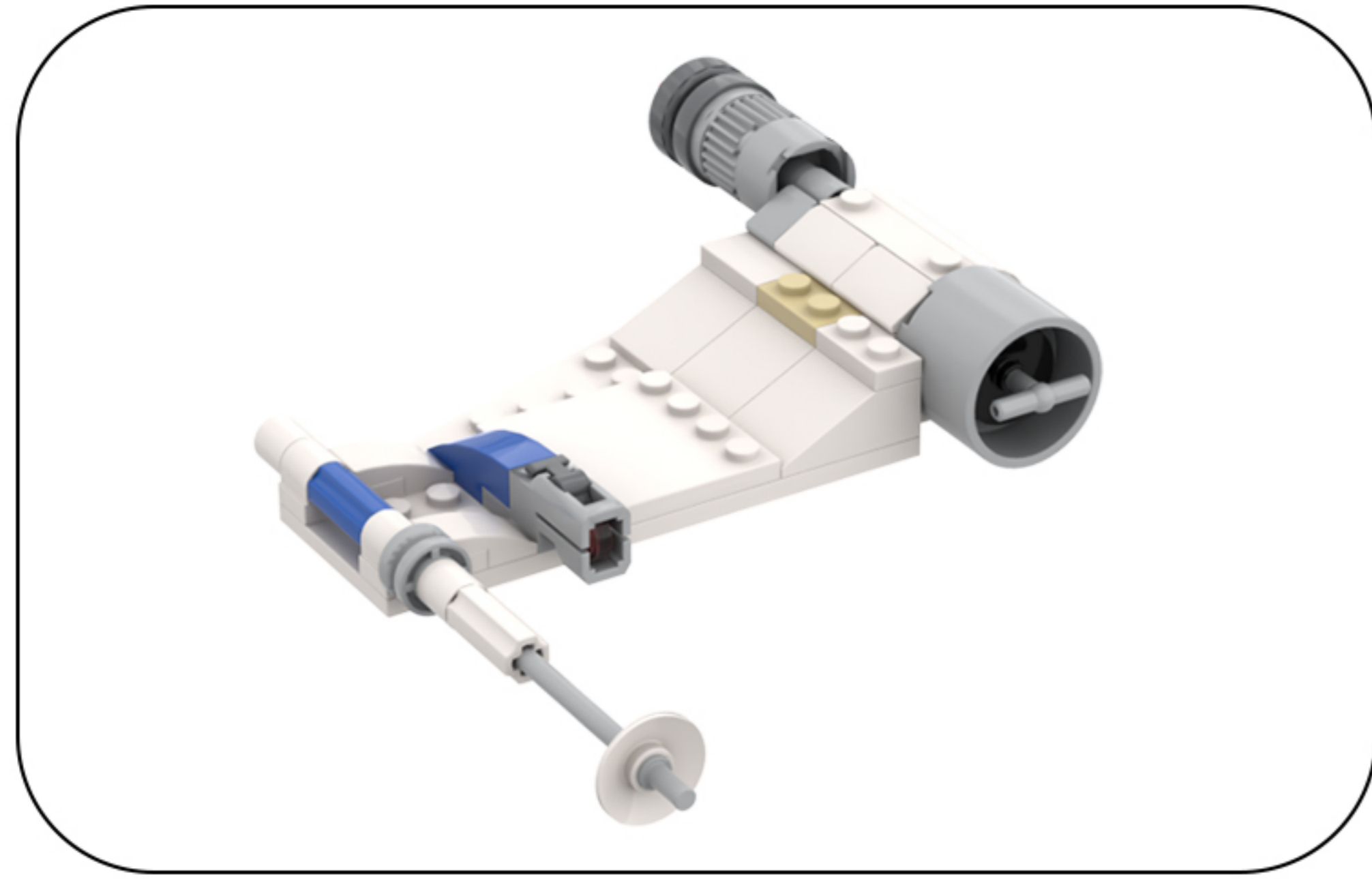

3

EN: Take the two disassembled building blocks; they have the same lighting fixtures. Let's use the block on the left as an example.

DE: Take the two disassembled building blocks; they have the same lighting fixtures. Let's use the block on the left as an example.

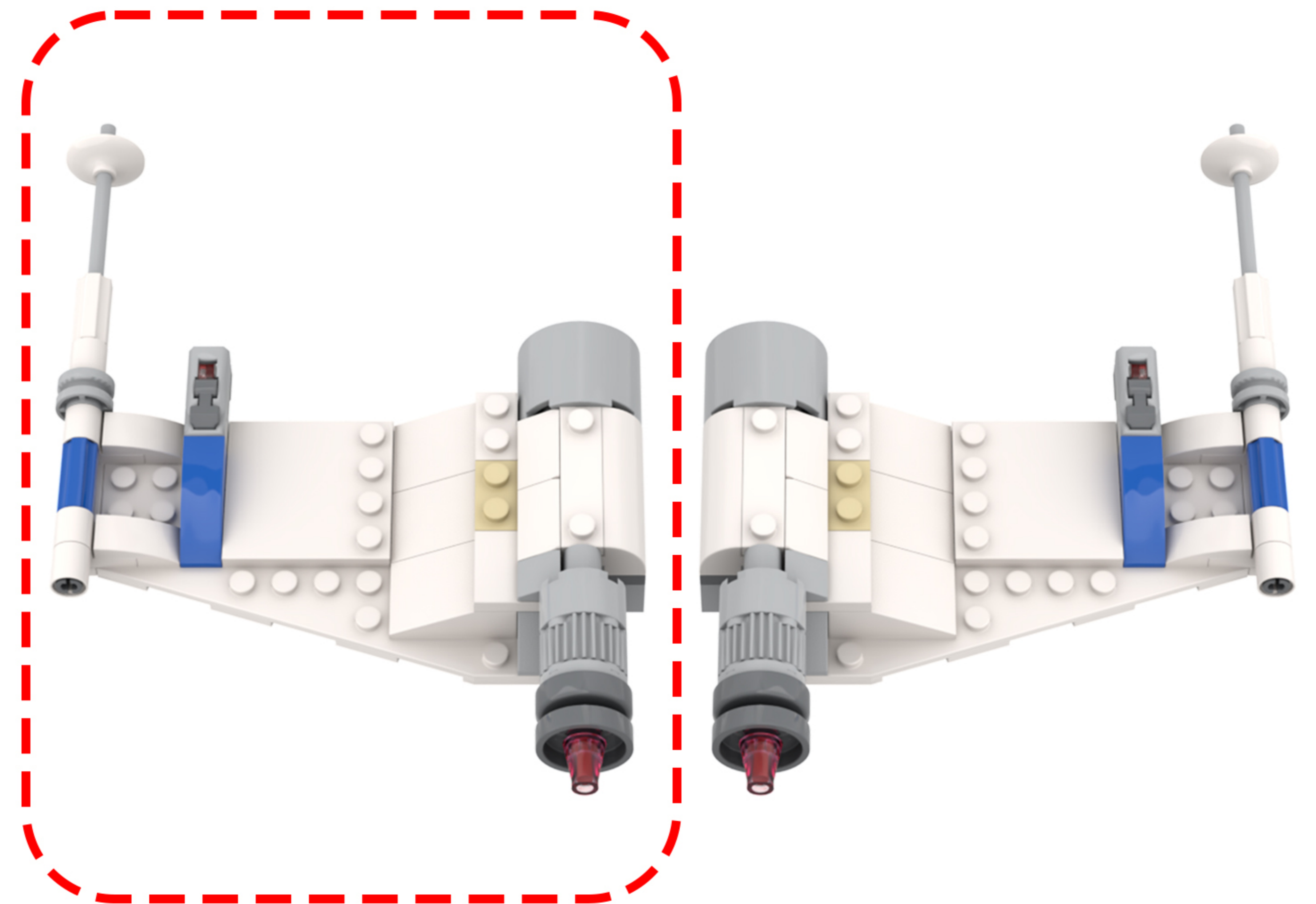

4

EN: Remove the building blocks one by one.  
DE: Entfernen Sie die Bausteine nacheinander.

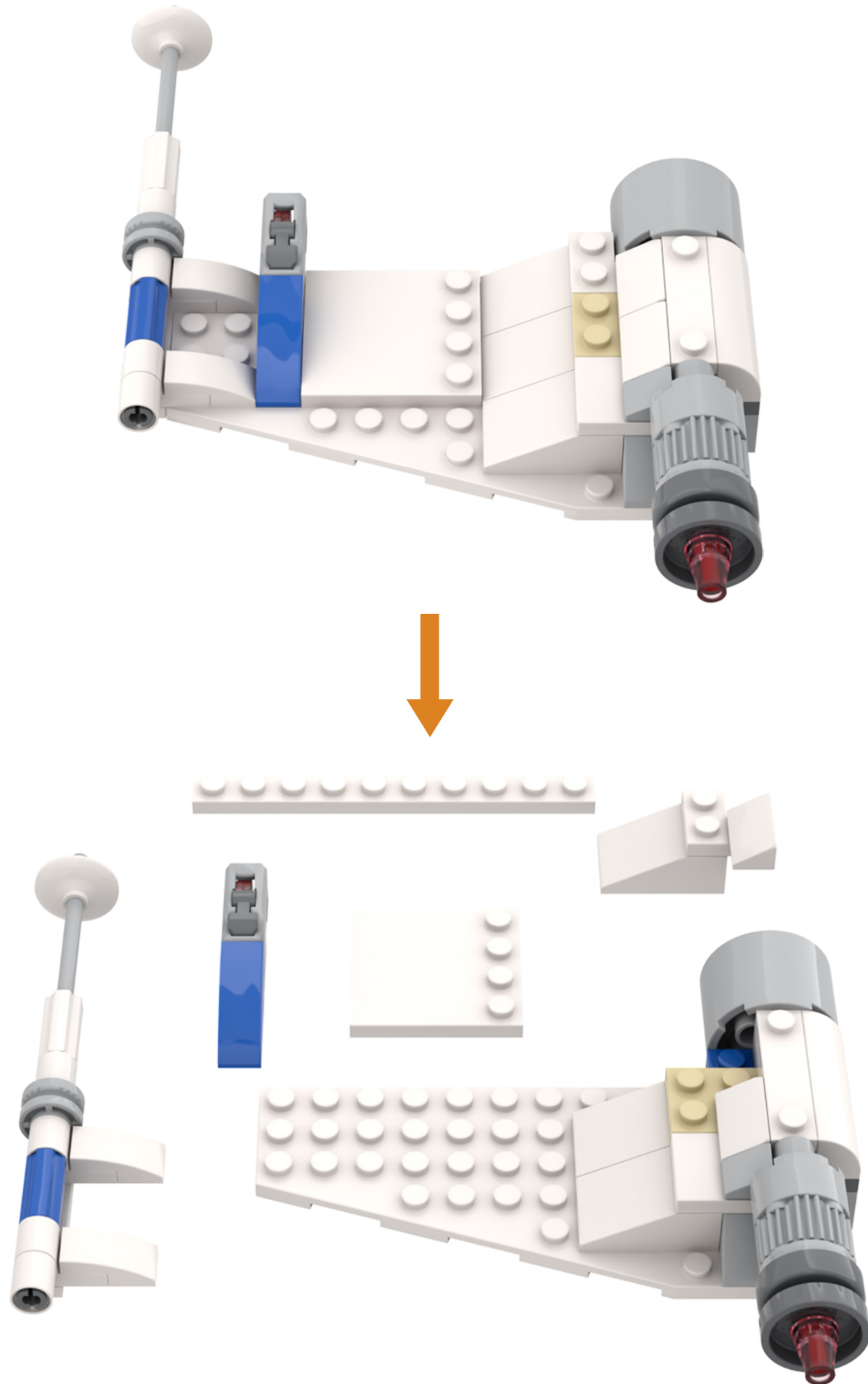

5

EN: Take out the string of lights from Bag 1 and the disassembled building blocks.  
DE: Nimm die Lichterkette aus Beutel 1 und die zerlegten Bausteine heraus.

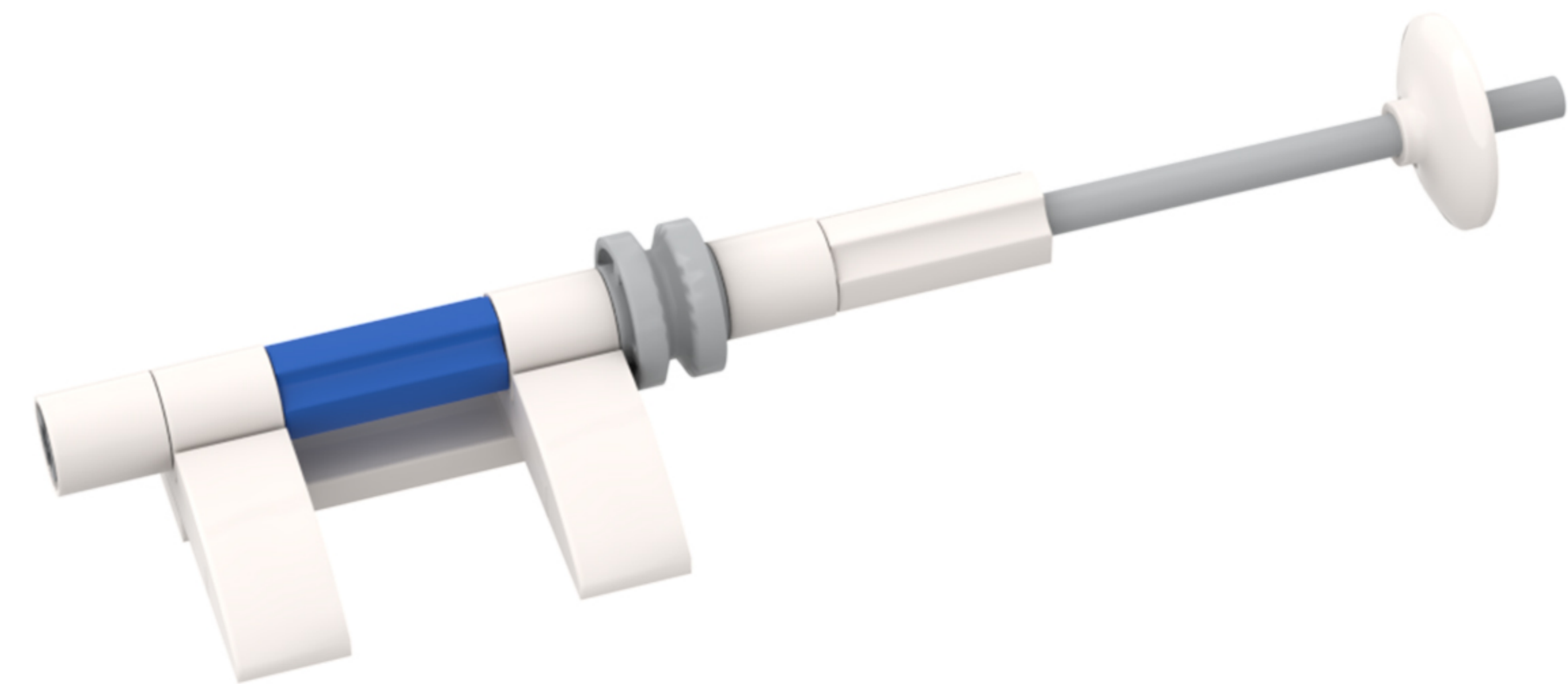
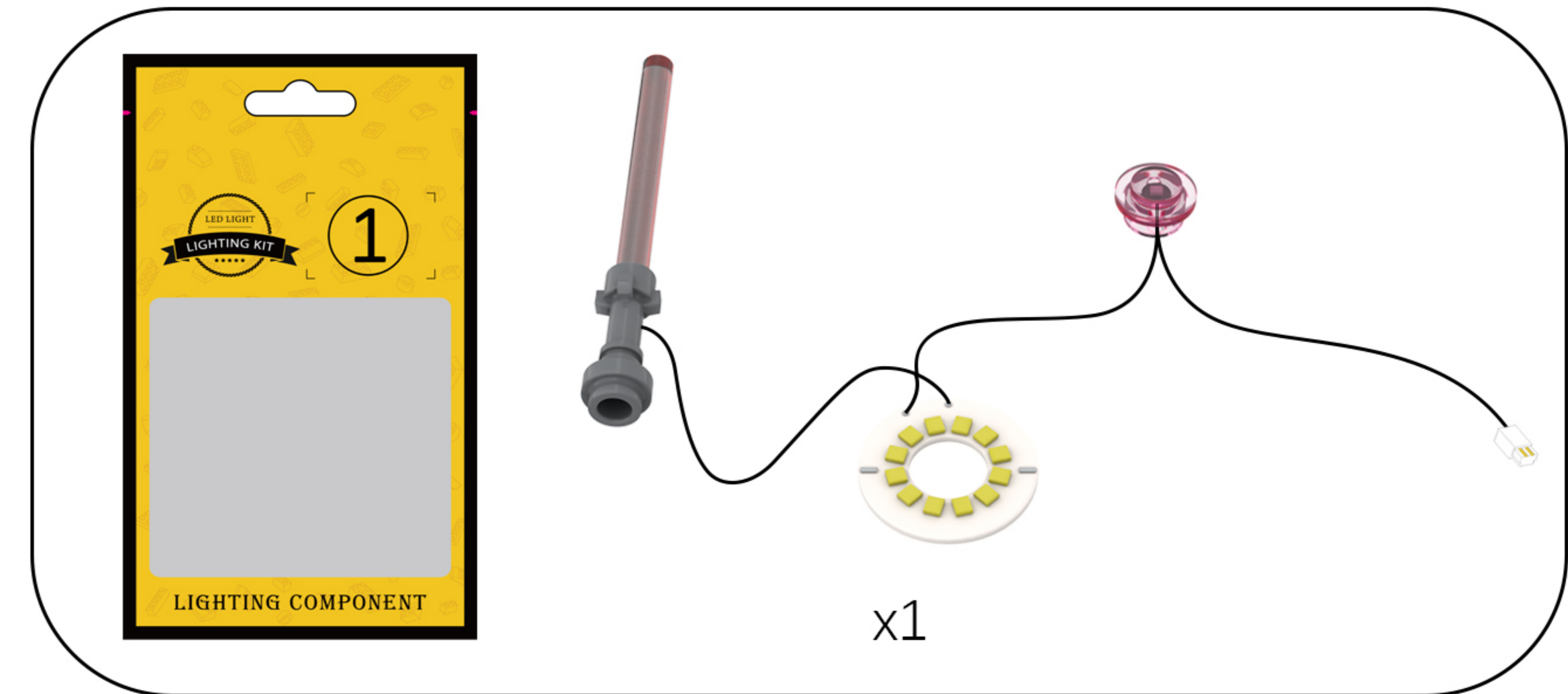

6

EN: Attach the lights from the string to the building blocks.

DE: Befestigen Sie die Lichter der Lichterkette an den Bausteinen.

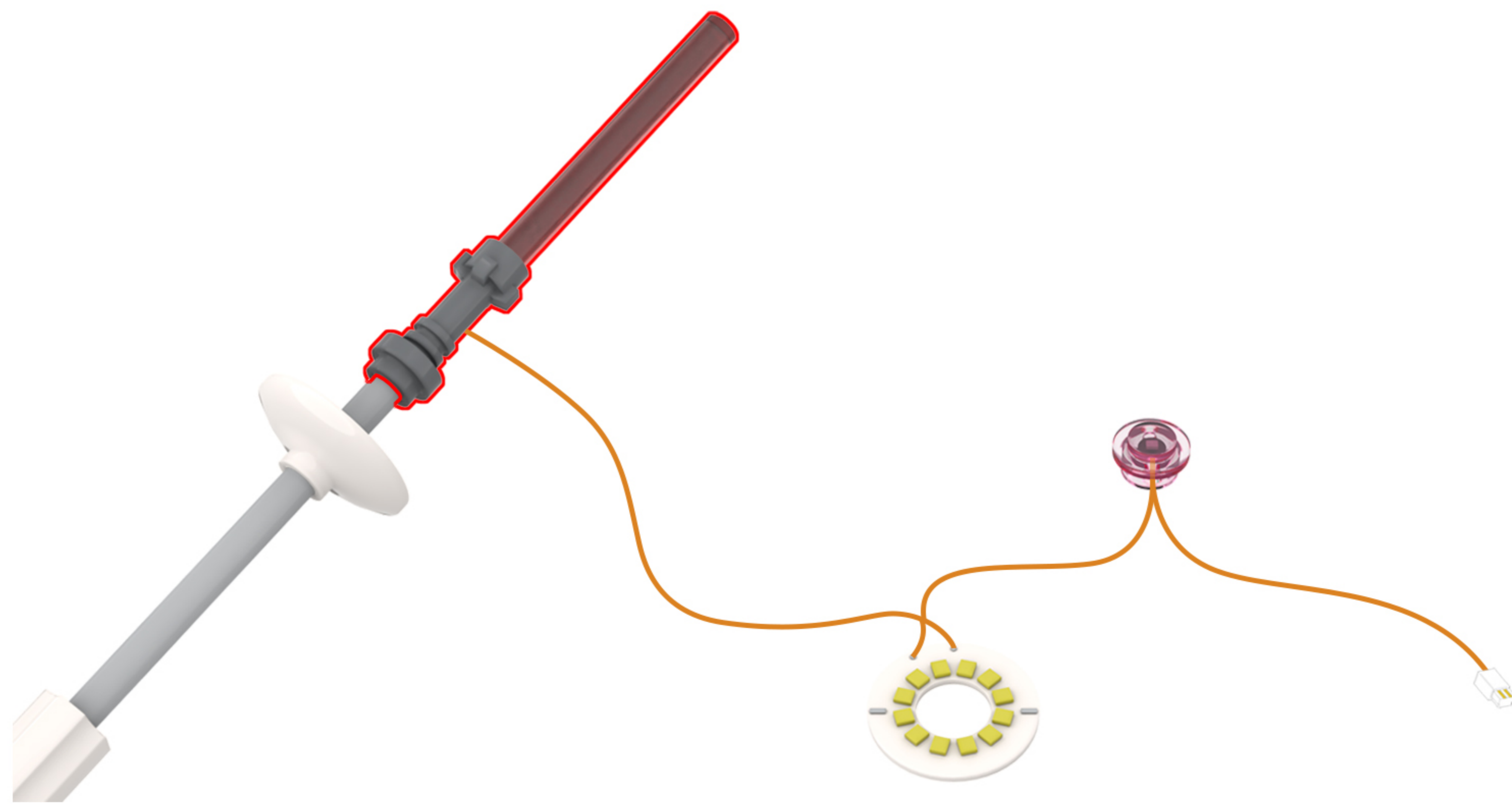

7

EN: Arrange the lighting lines according to the diagram.

DE: Ordnen Sie die Beleuchtungslinien gemäß der Abbildung an.

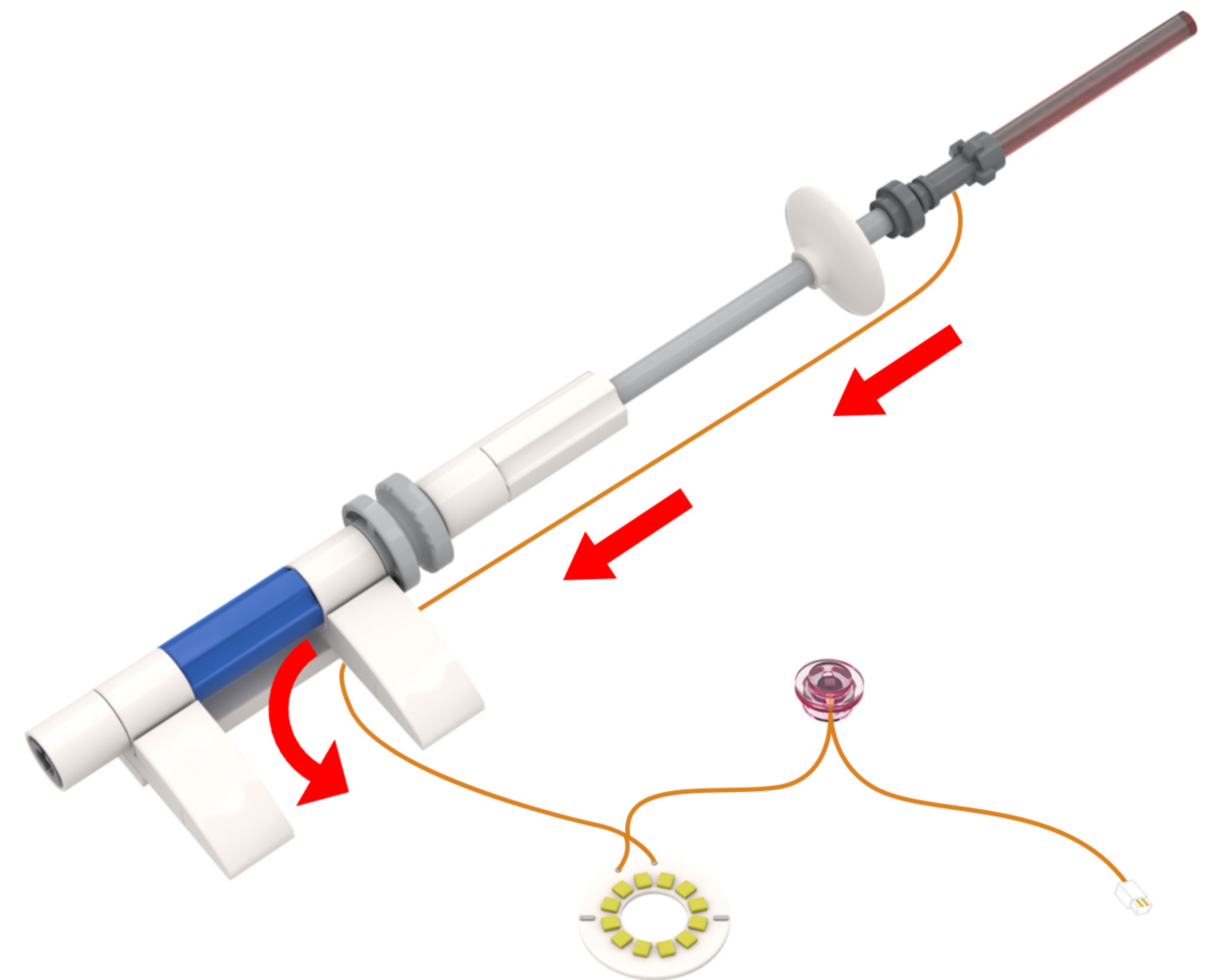

8

EN: Take out the disassembled building blocks, reassemble them, and secure the light cord.

DE: Nehmen Sie die zerlegten Bausteine heraus, setzen Sie sie wieder zusammen und befestigen Sie das Lichtkabel.

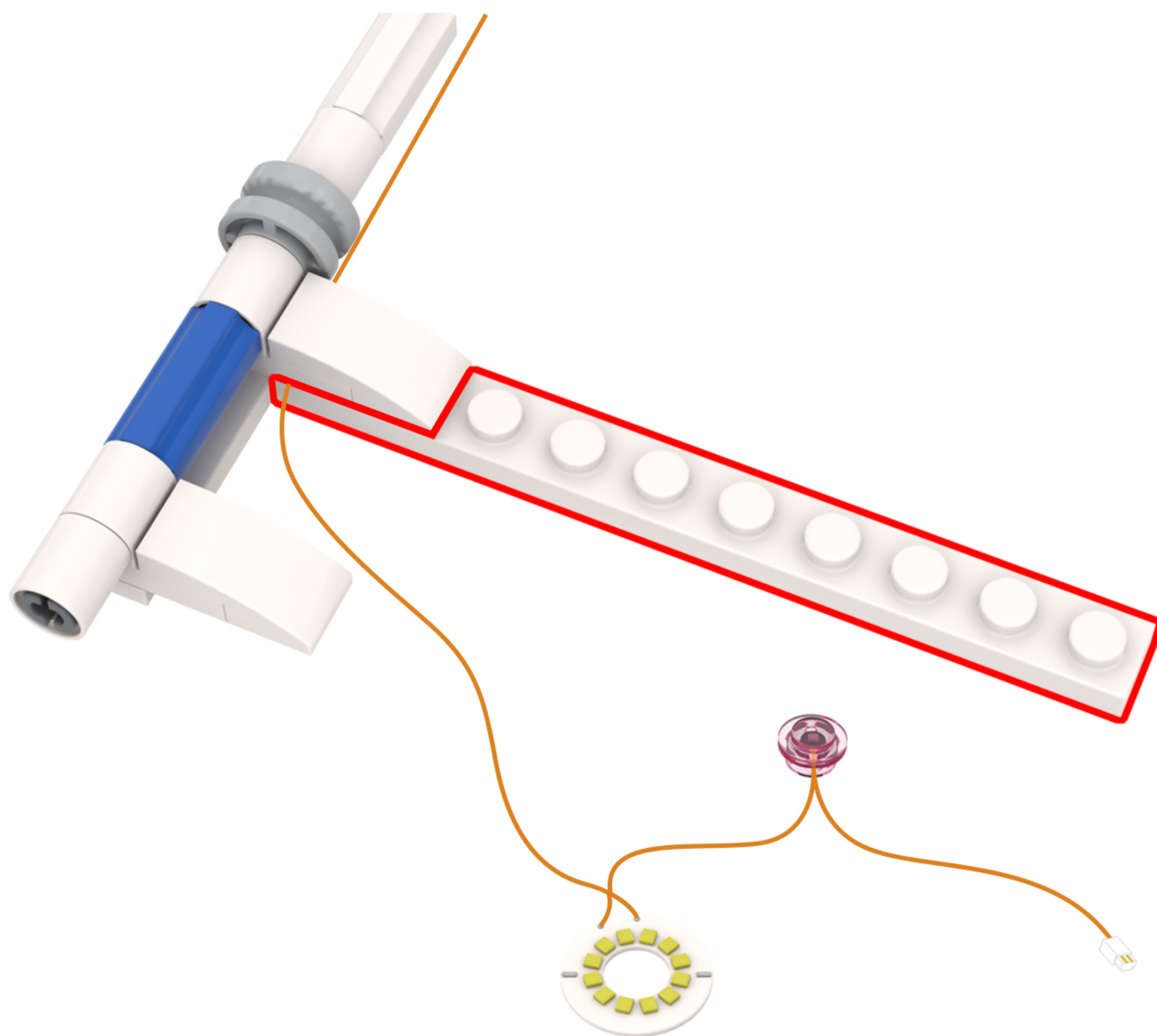
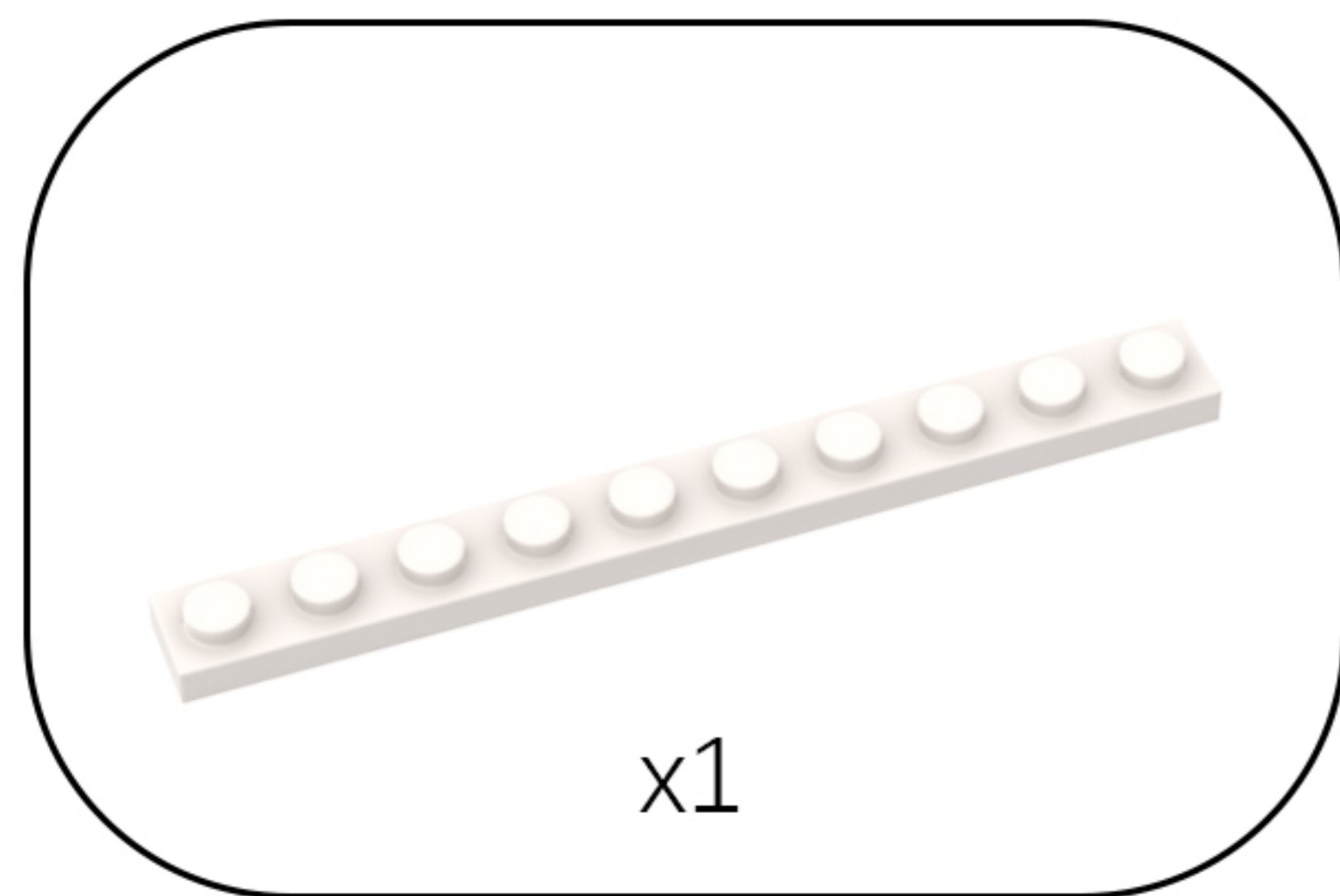

9

EN: Take out the disassembled building blocks and reassemble them.

DE: Nehmen Sie die zerlegten Bausteine heraus und setzen Sie sie wieder zusammen.

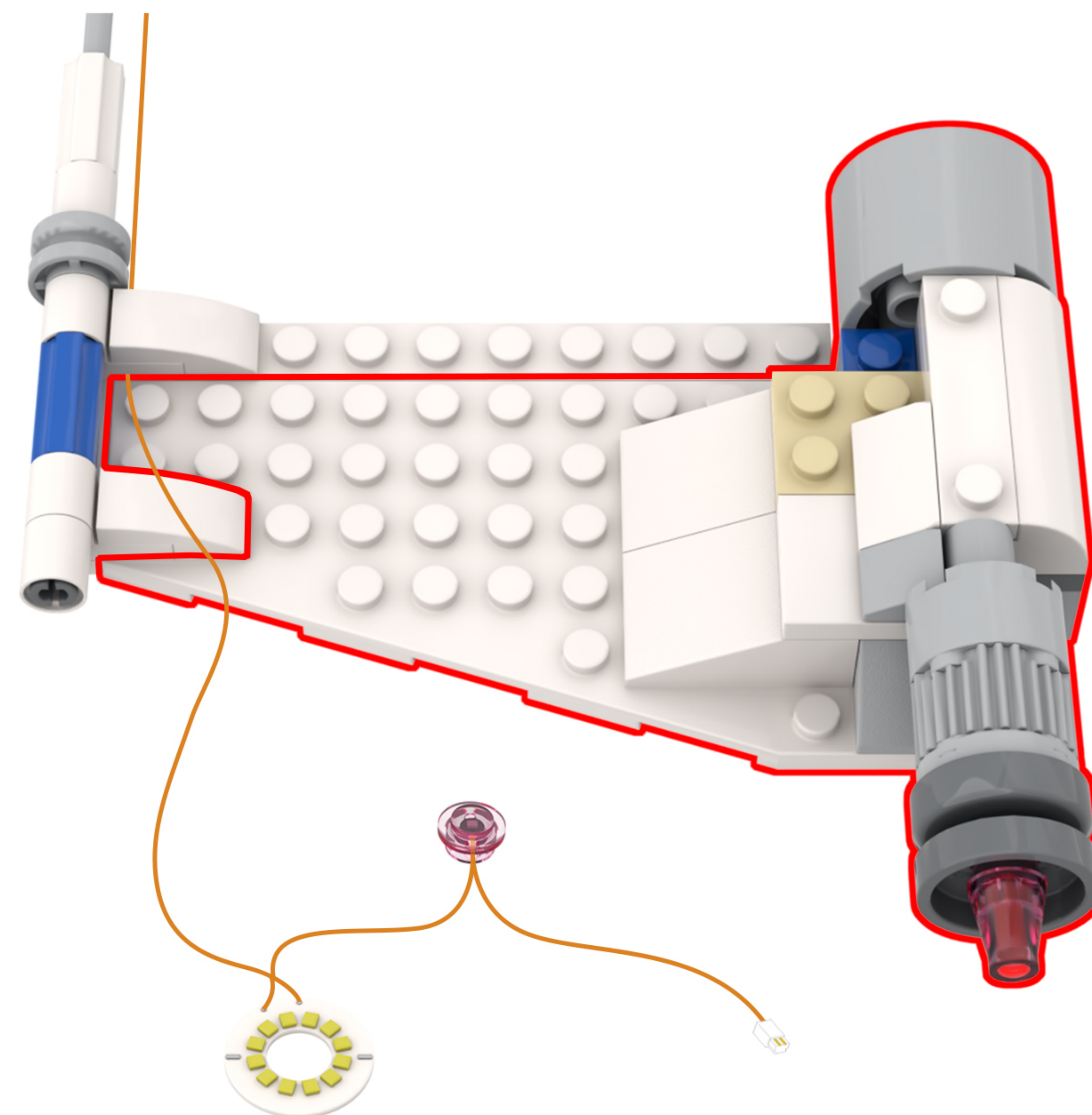
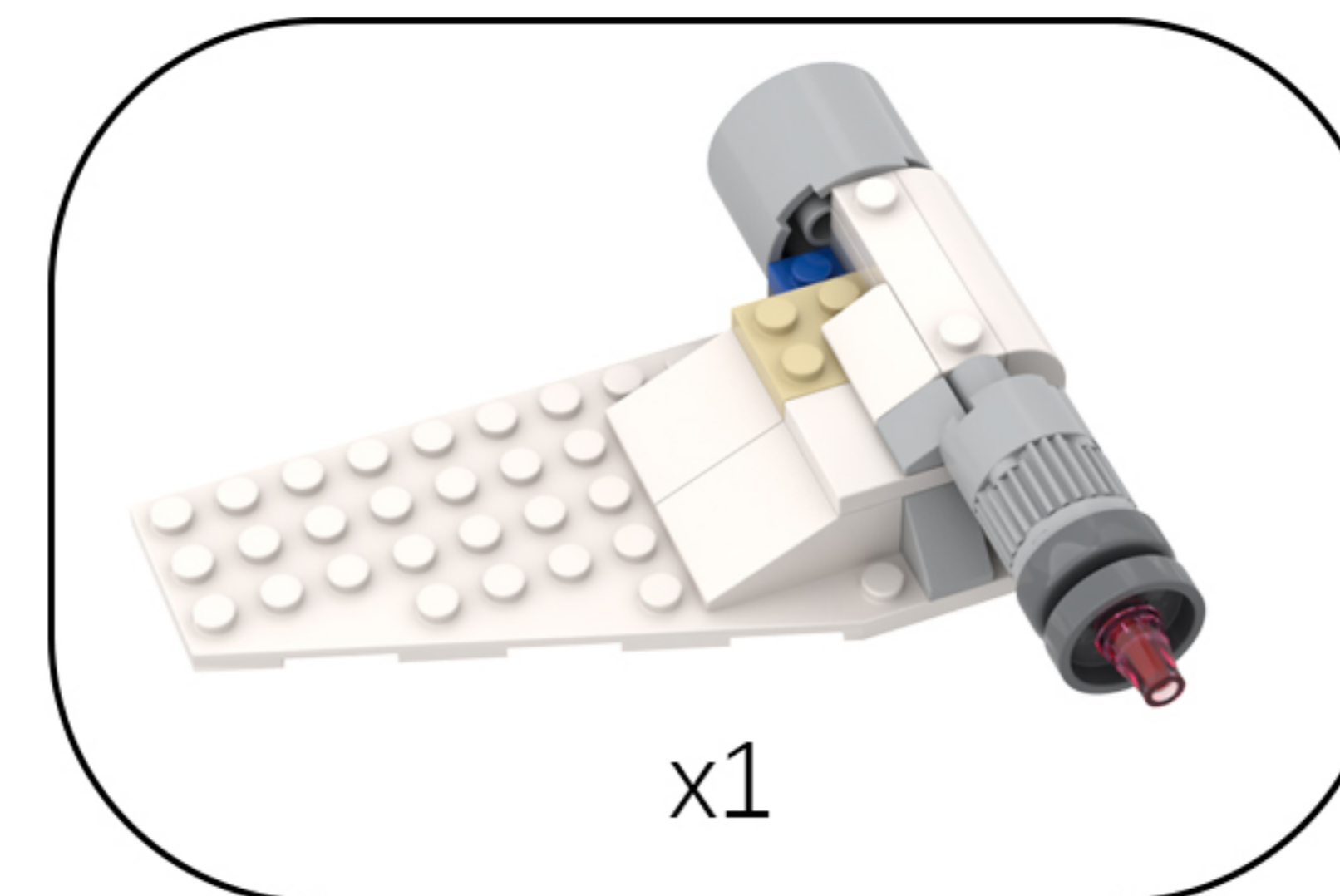

10

EN: Find the wire in the string of lights.

DE: Finde den Draht in der Lichterkette.

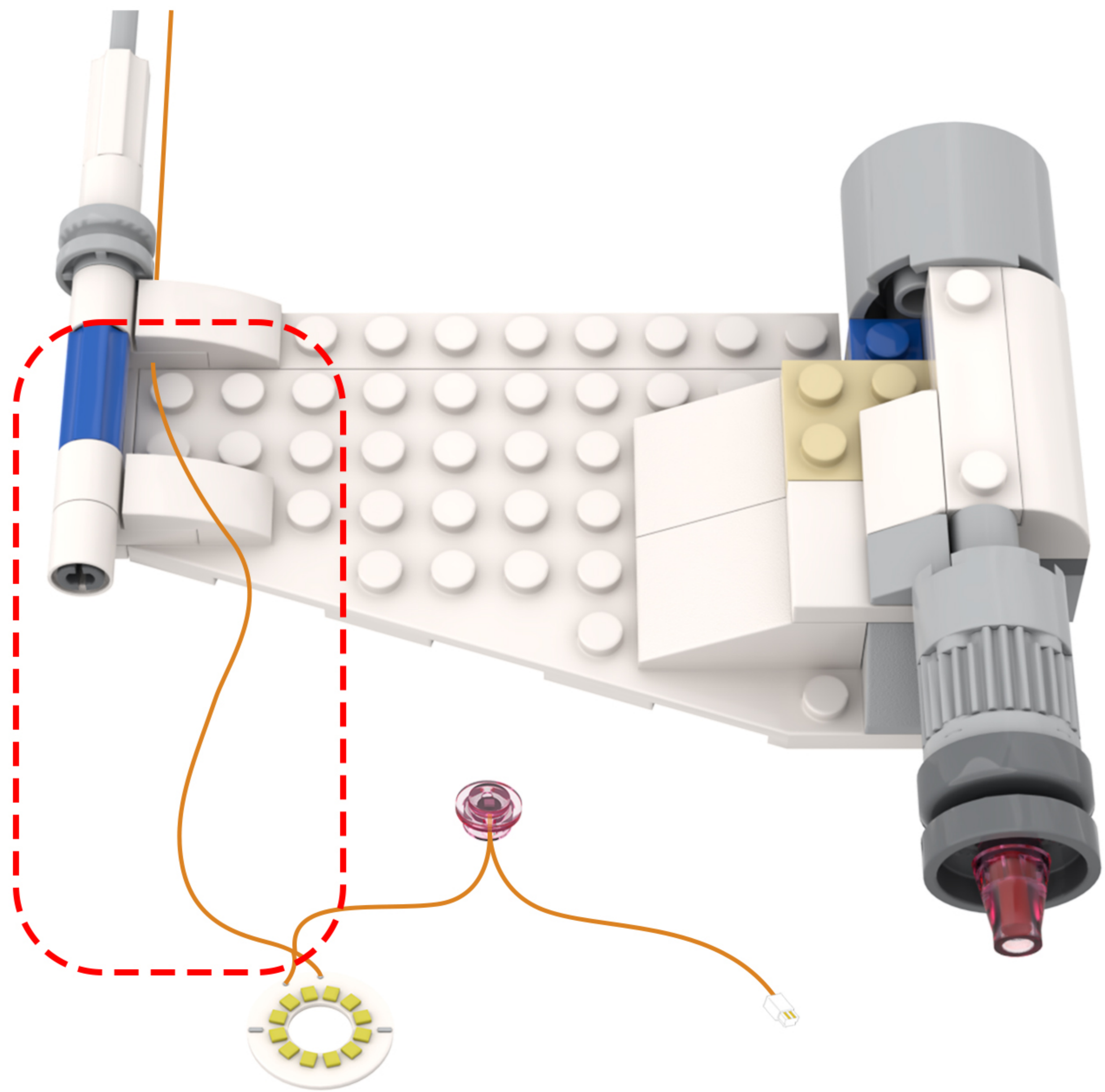

11

EN: Route the light cable to the right, avoiding the protrusions on the building blocks.

DE: Verlegen Sie das Lichtkabel nach rechts und umgehen Sie dabei die Vorsprünge an den Bausteinen.

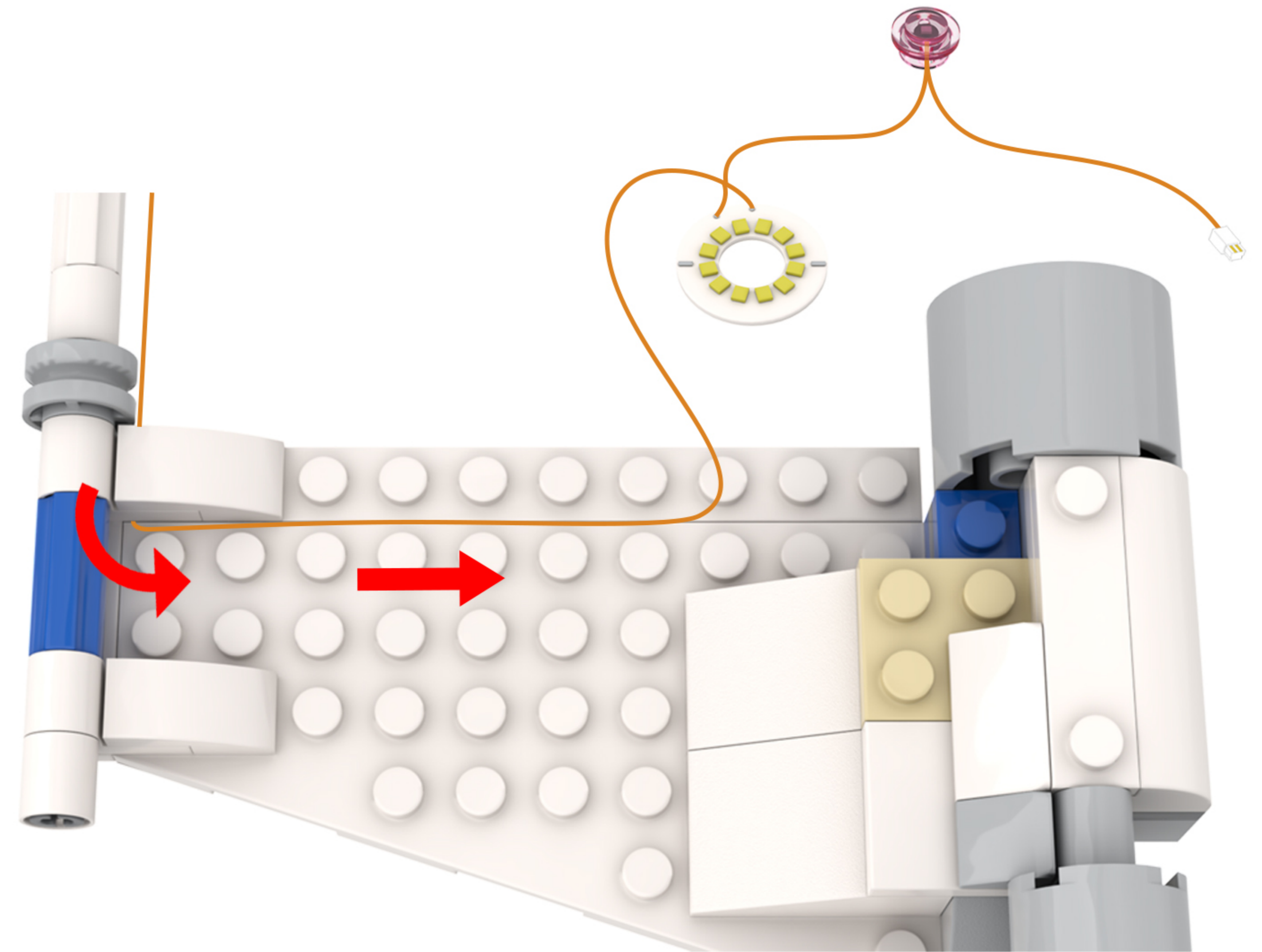

12

EN: Take out the disassembled building blocks, reassemble them, and secure the light cord.

DE: Nehmen Sie die zerlegten Bausteine heraus, setzen Sie sie wieder zusammen und befestigen Sie das Lichtkabel.

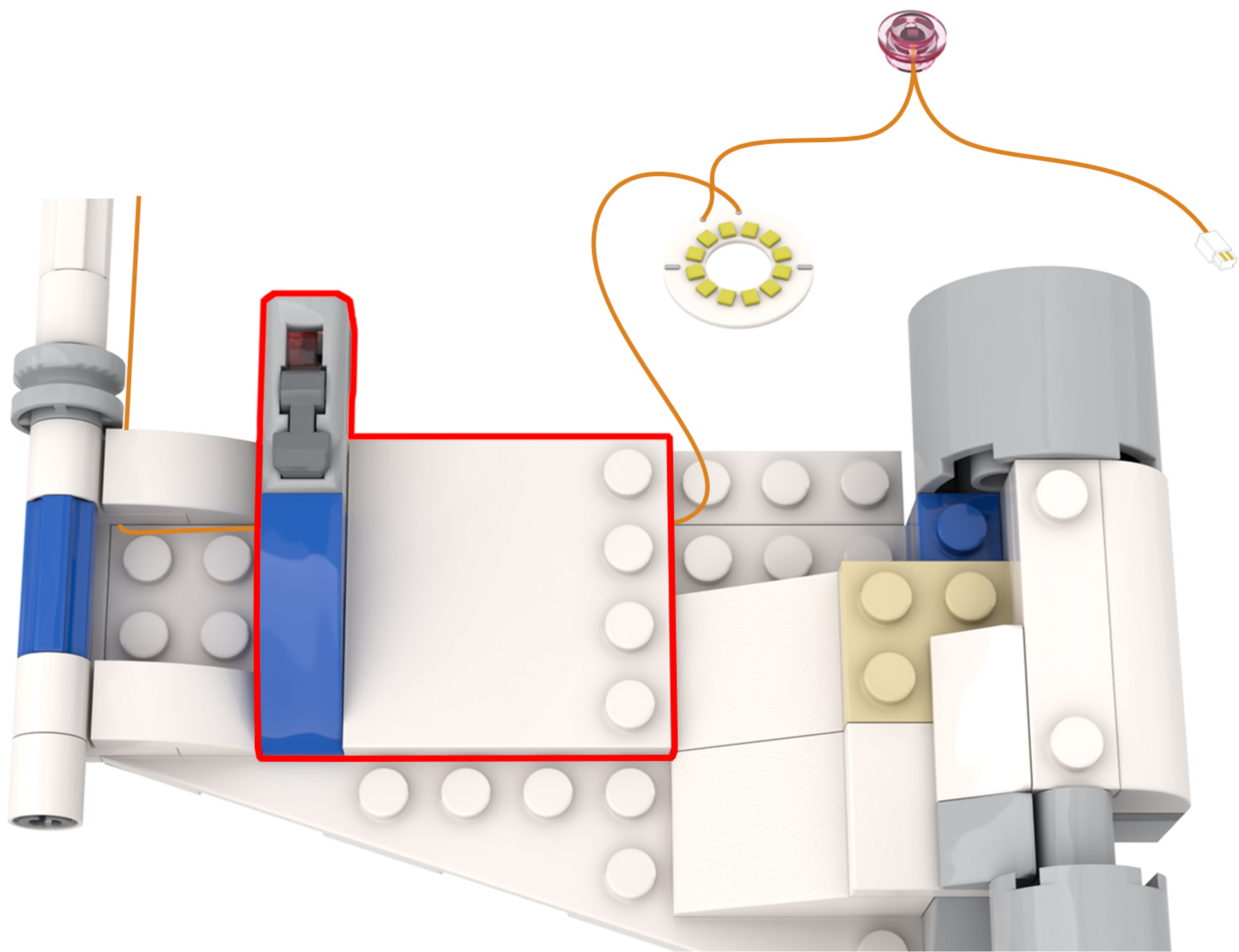
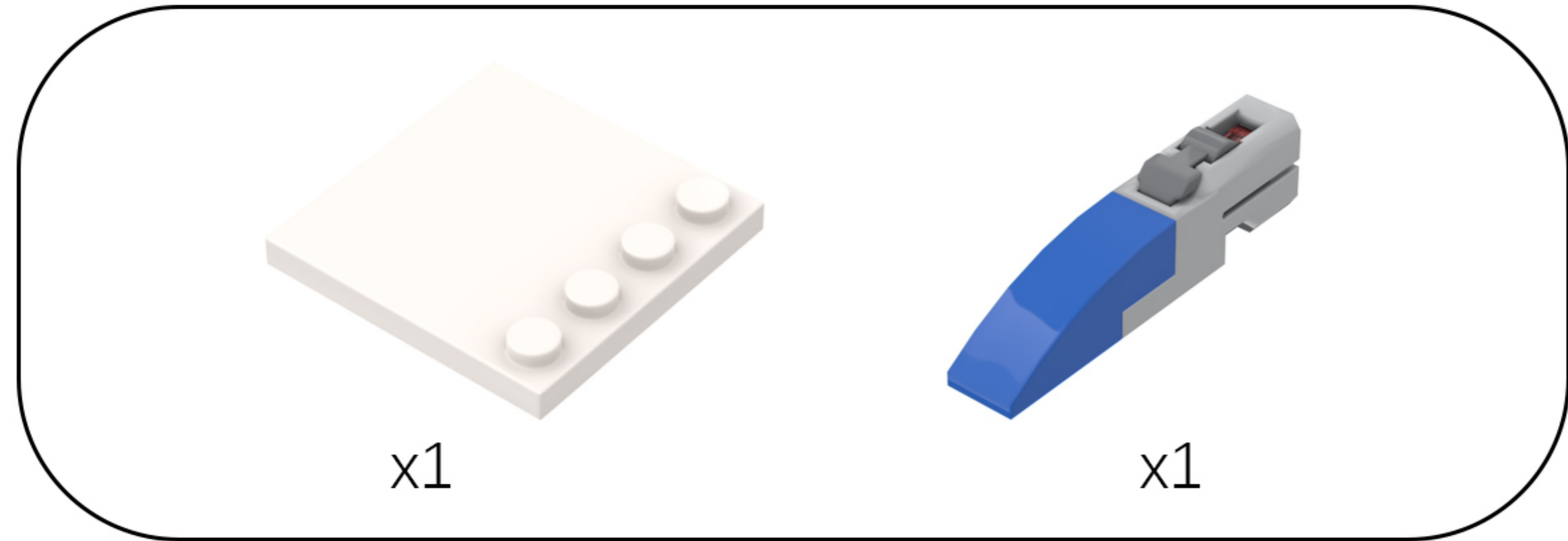

13

EN: Find the building blocks shown in the picture.

DE: Finde die auf dem Bild abgebildeten Bausteine.

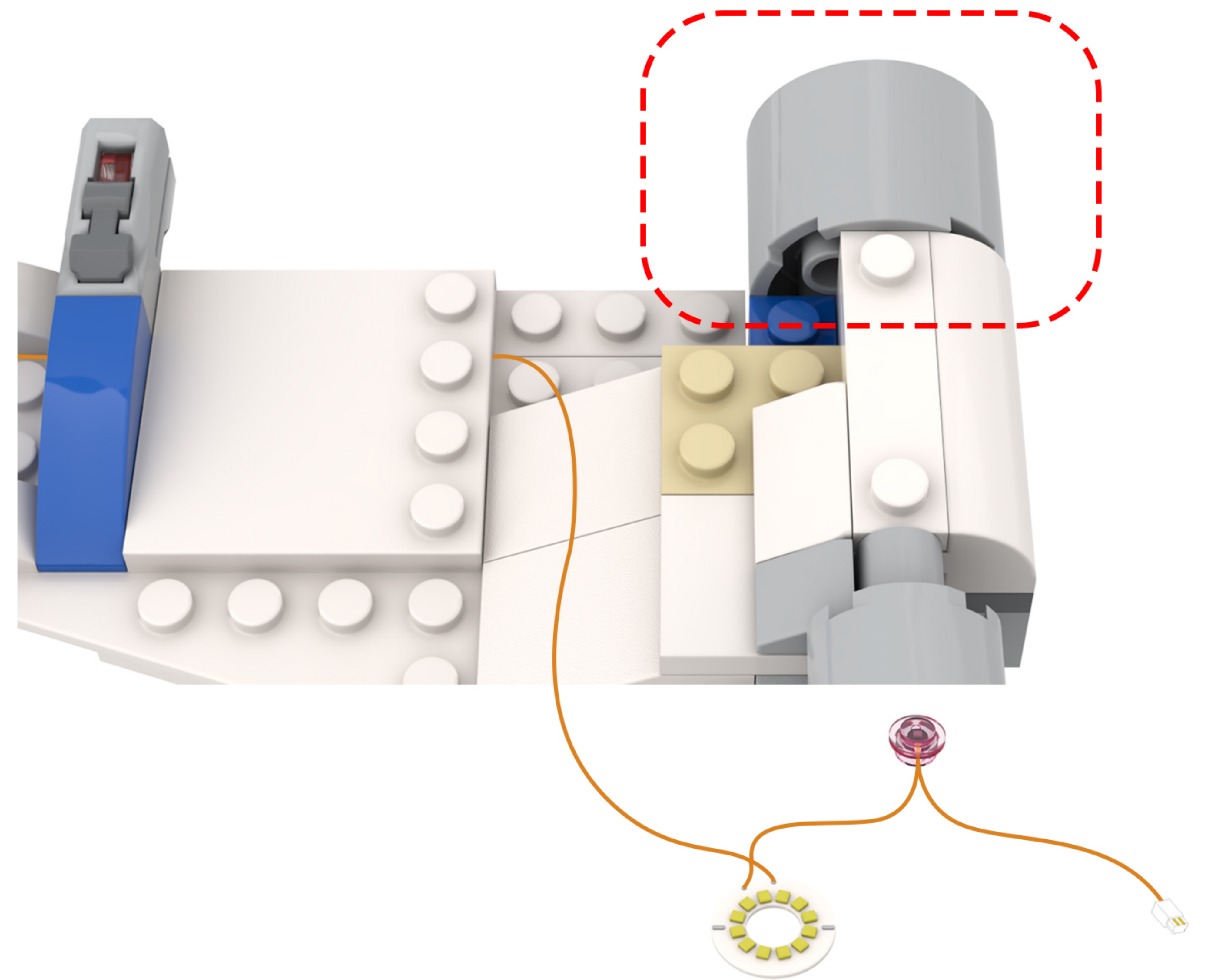

14

EN: Pull the building block out slightly.

DE: Zieh den Baustein ein wenig heraus.

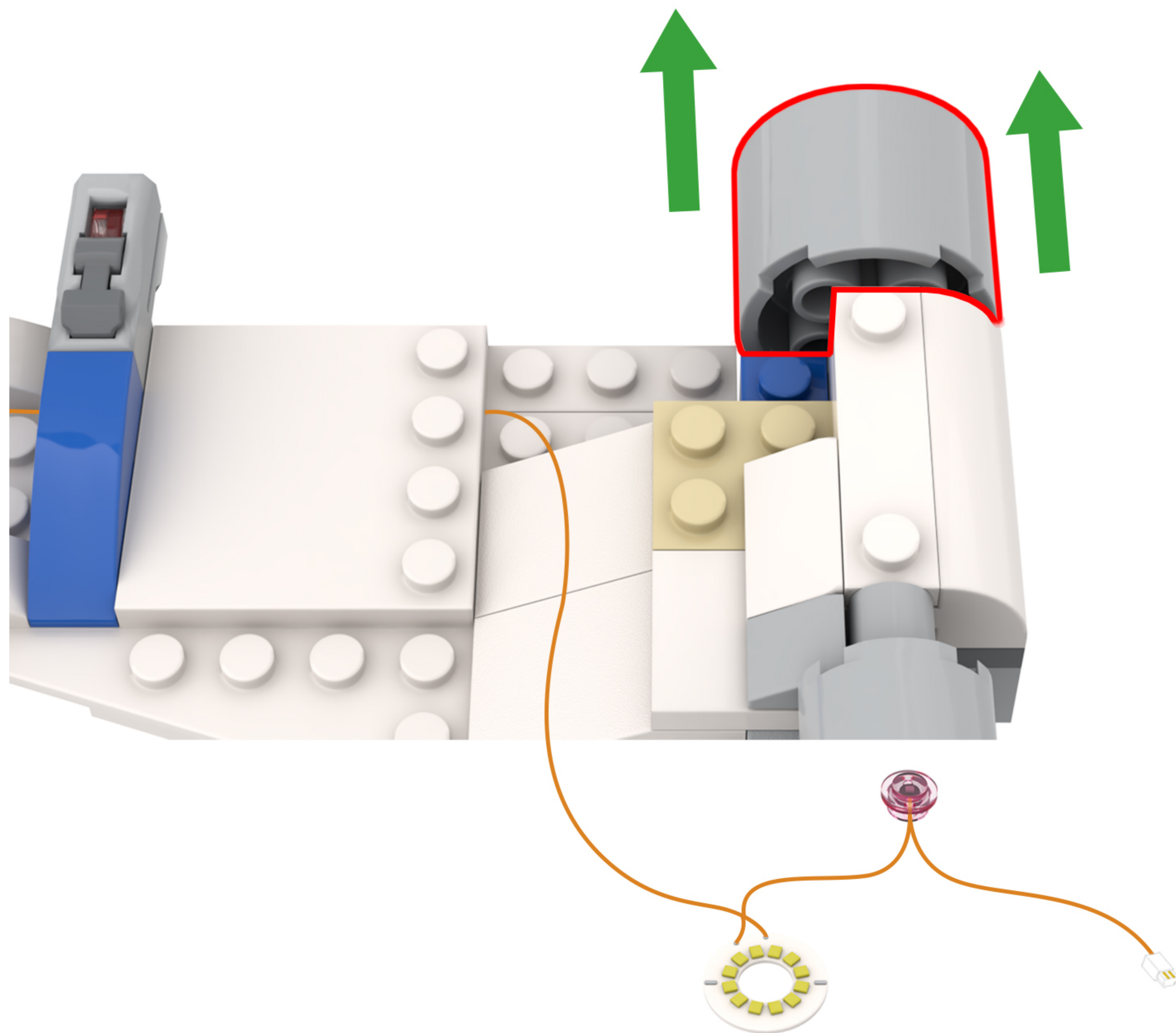

15

EN: Thread the lamp cord through the gaps in the building blocks.

DE: Führen Sie das Lampenkabel durch die Lücken in den Bausteinen.

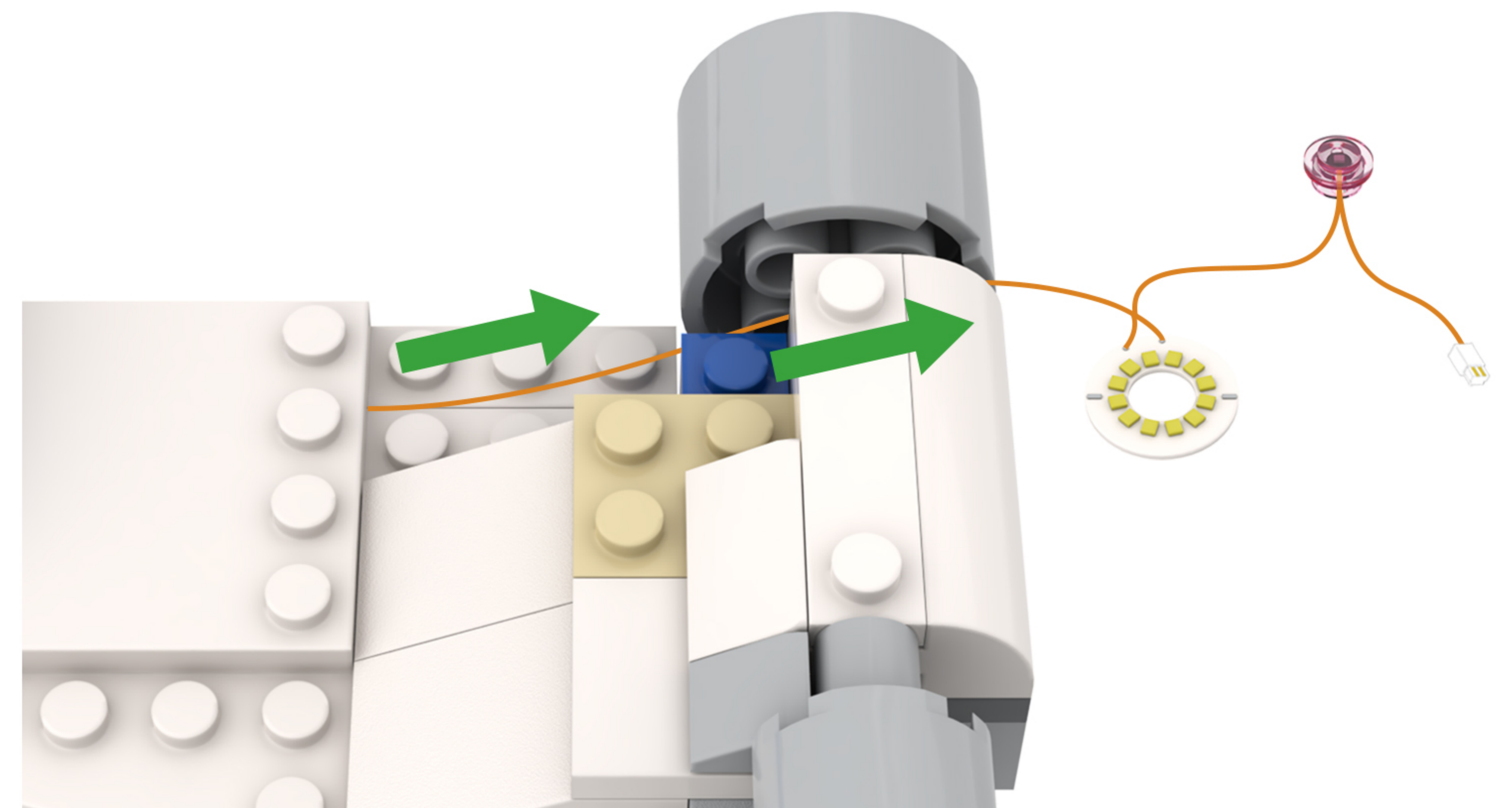

16

EN: Take out the disassembled building blocks, reassemble them, and secure the light cord.

DE: Nehmen Sie die zerlegten Bausteine heraus, setzen Sie sie wieder zusammen und befestigen Sie das Lichtkabel.

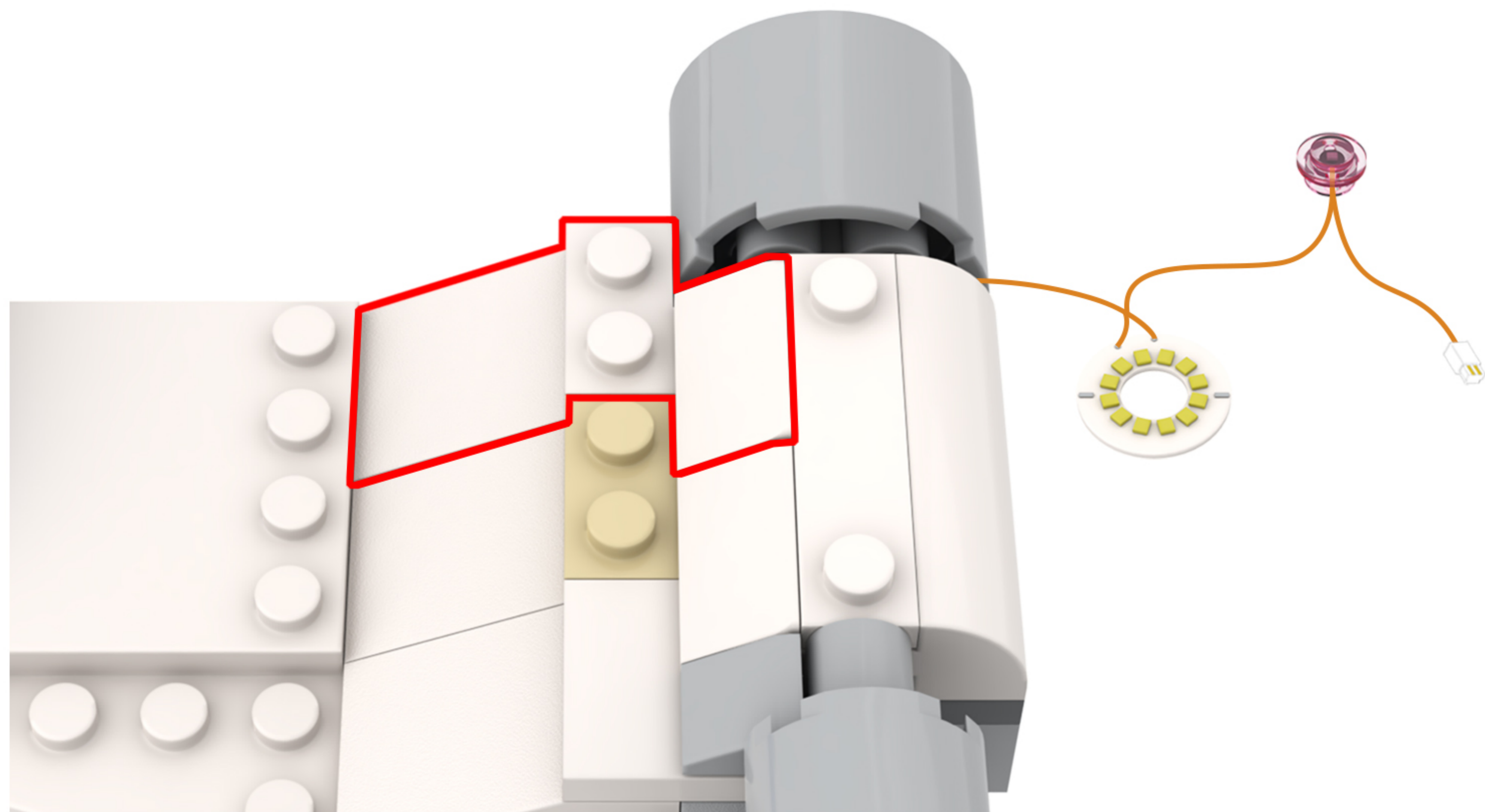
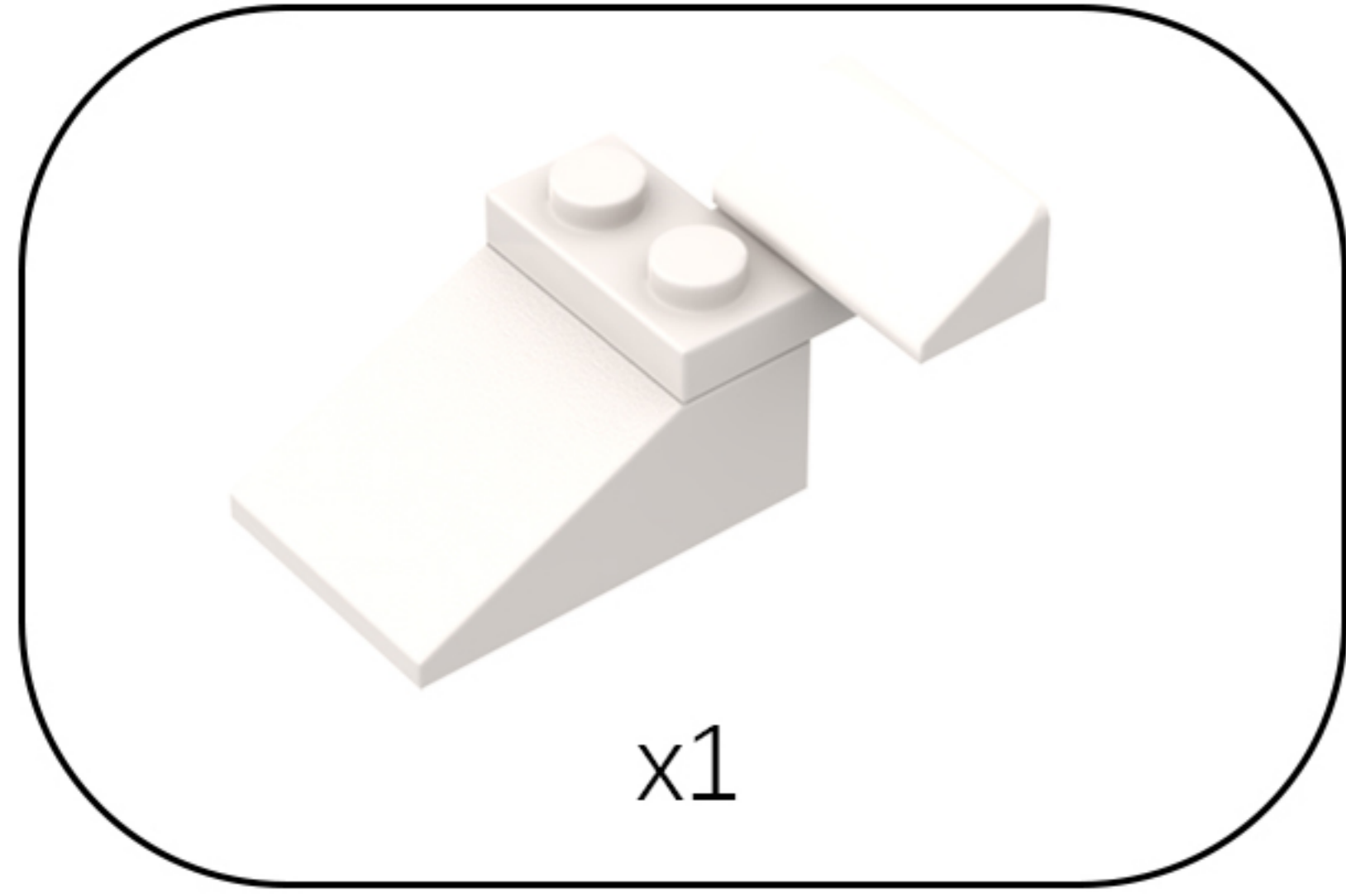

17

EN: Rotate the model to its back side.

DE: Drehen Sie das Modell auf die Rückseite.

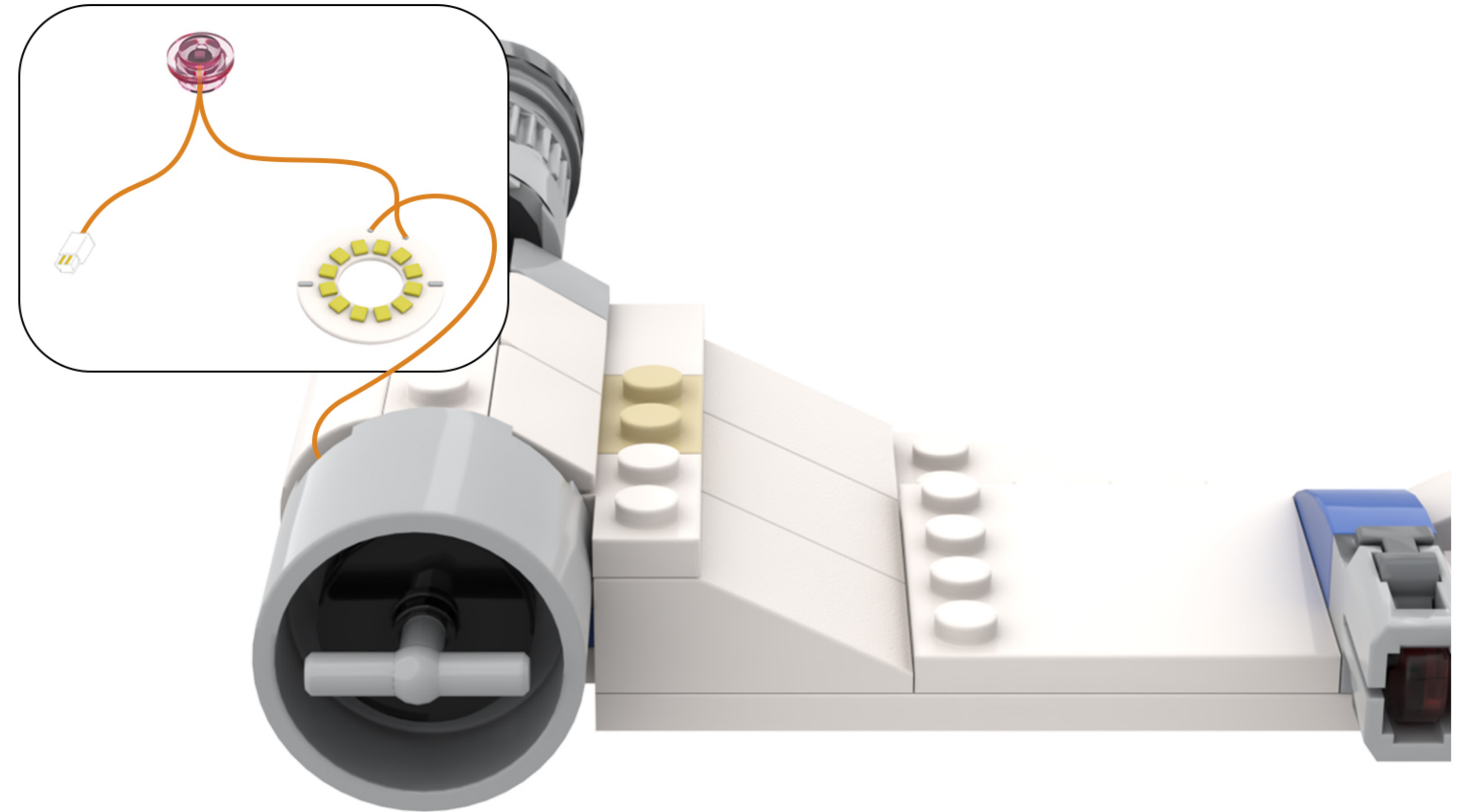

18

EN: Split as shown in the figure.

DE: Wie in der Abbildung gezeigt, teilen Sie es auf.

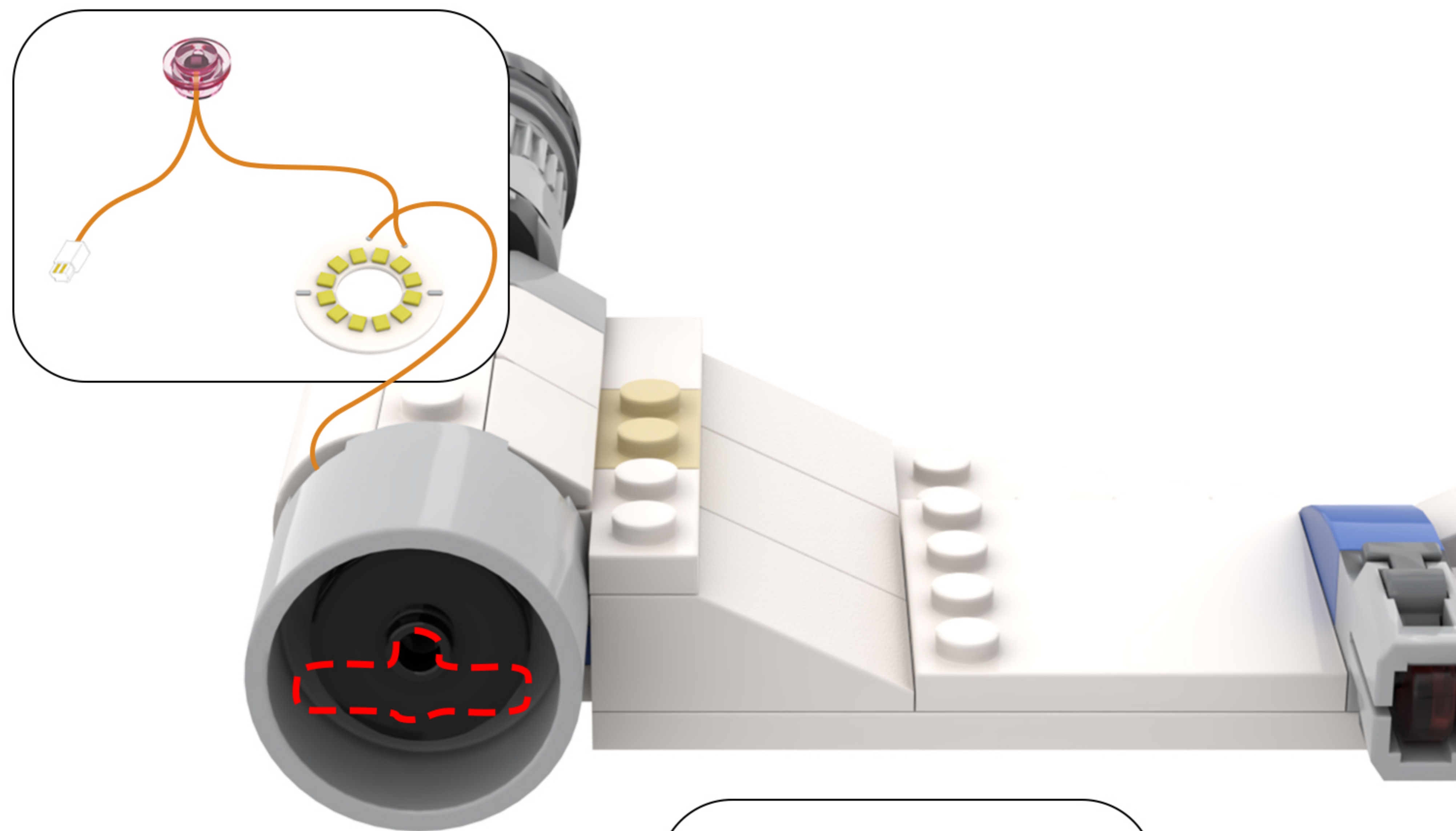

19

EN: Find the disc-shaped lights on the string of lights.

DE: Finde die scheibenförmigen Lichter an der Lichterkette.

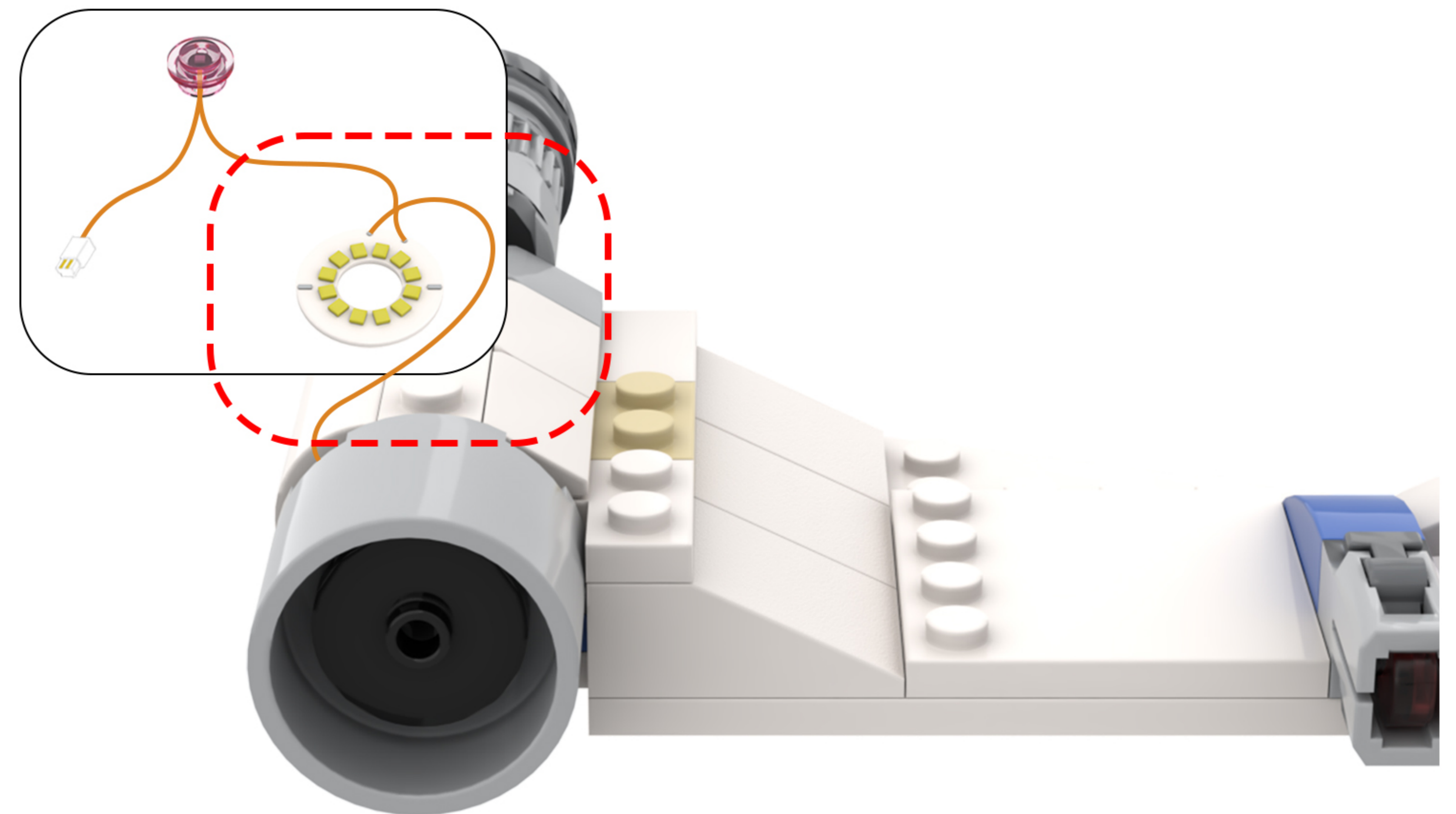

20

EN: Place the disc lights from the string of lights onto the building blocks.

DE: Befestige die runden Lichter der Lichterkette an den Bausteinen.

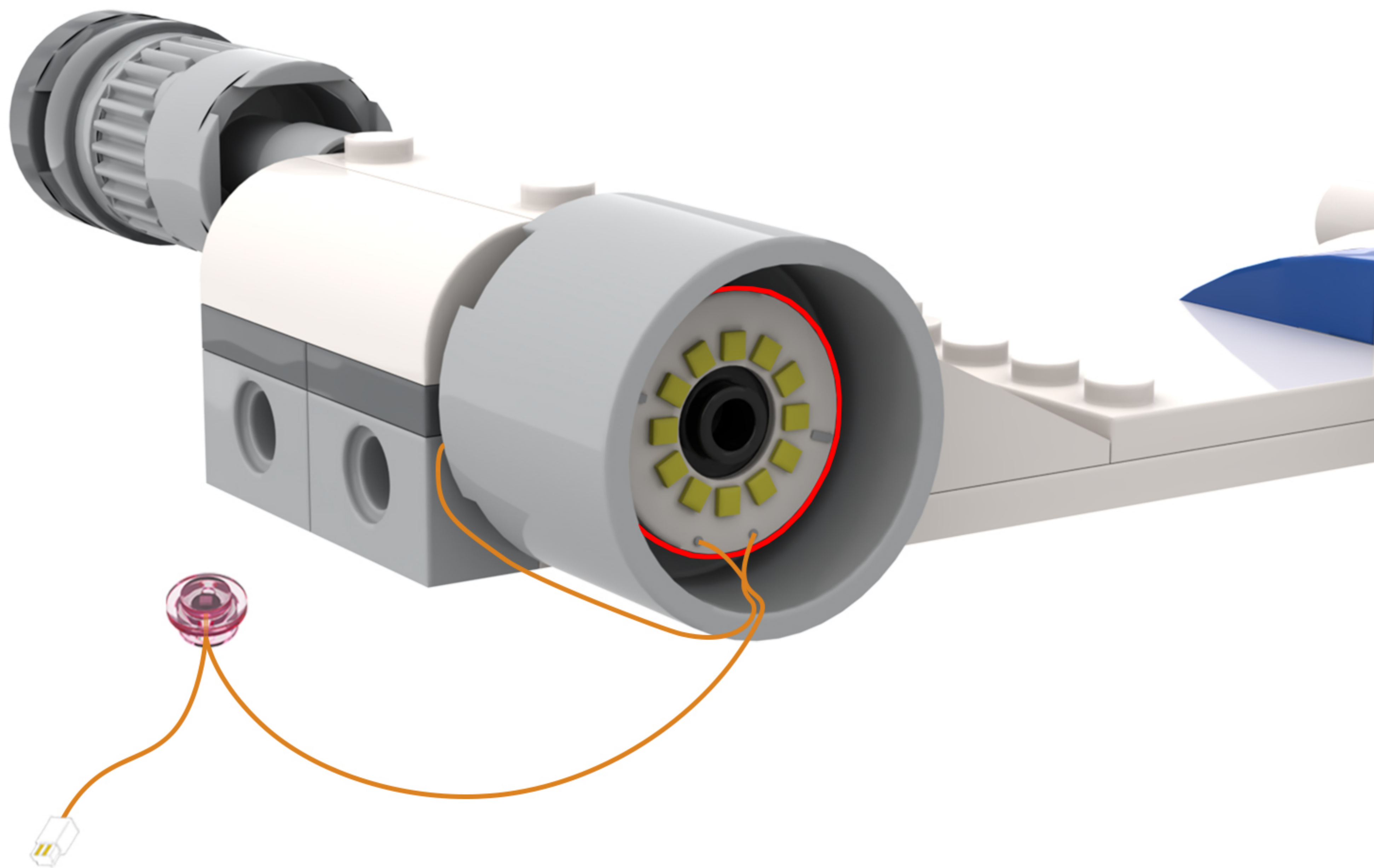

21

EN: Take out the disassembled building blocks and reassemble them.

DE: Nehmen Sie die zerlegten Bausteine heraus und setzen Sie sie wieder zusammen.

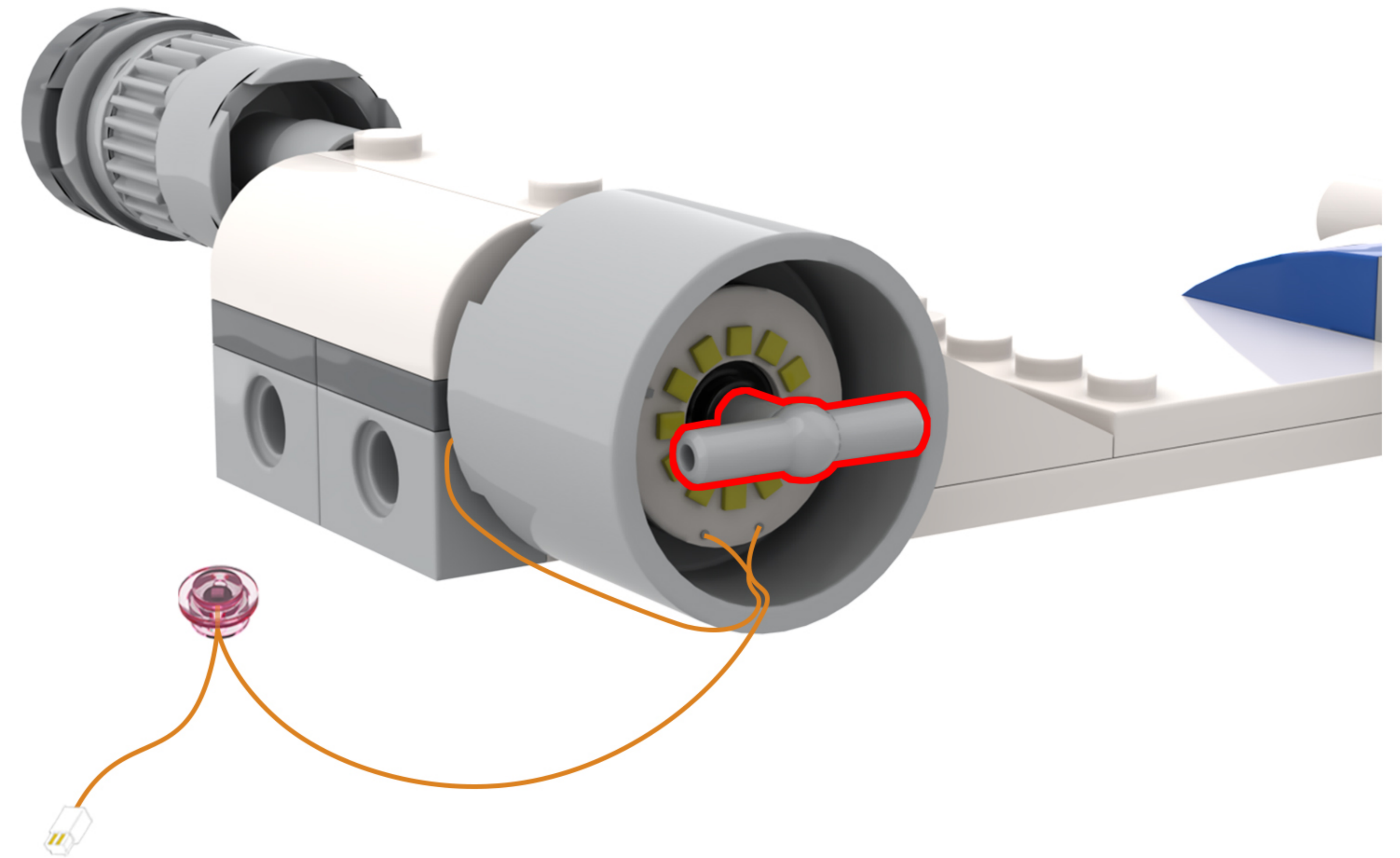
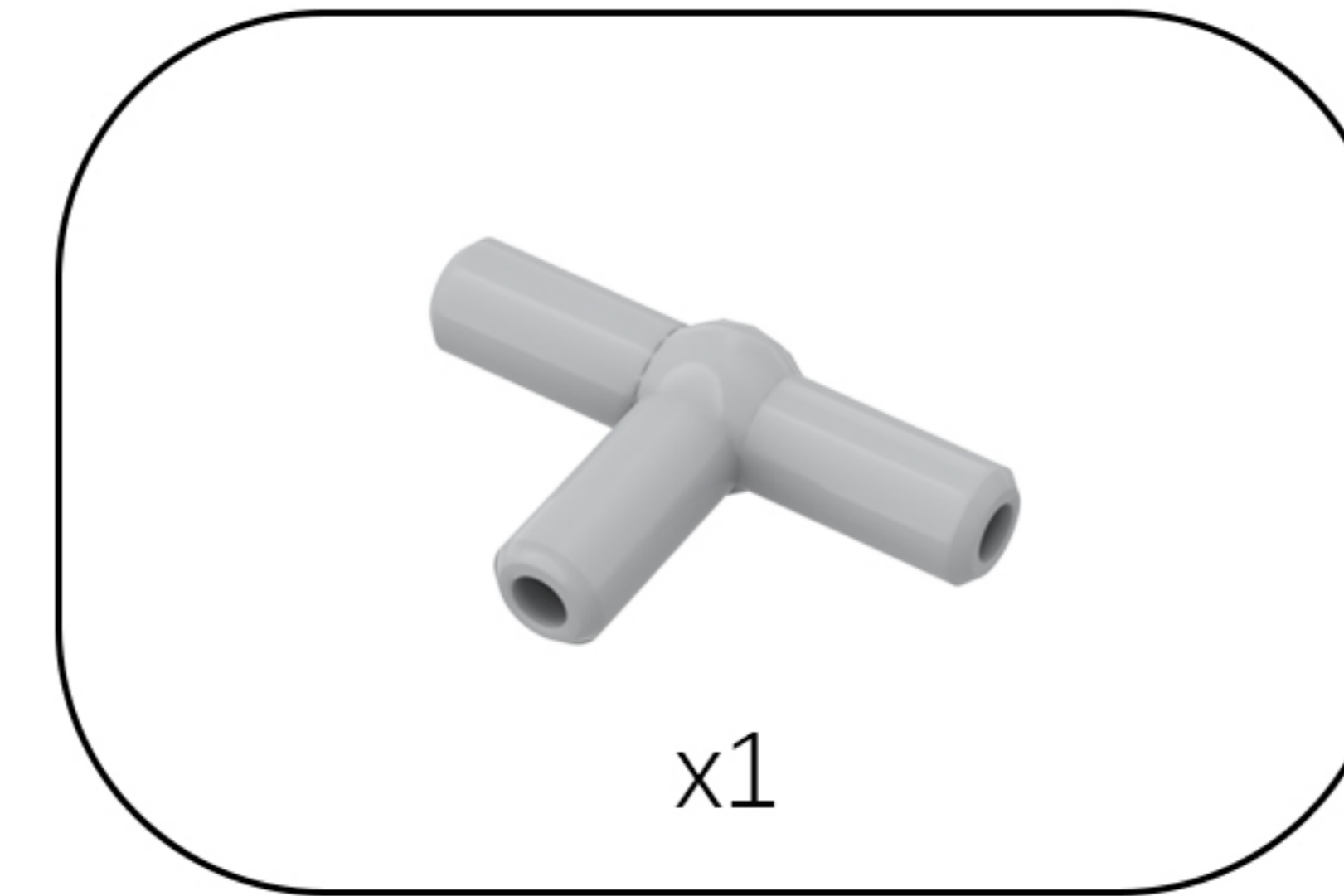

22

EN: Adjust the view and restore the block.

DE: Passen Sie die Ansicht an und stellen Sie den Block wieder her.

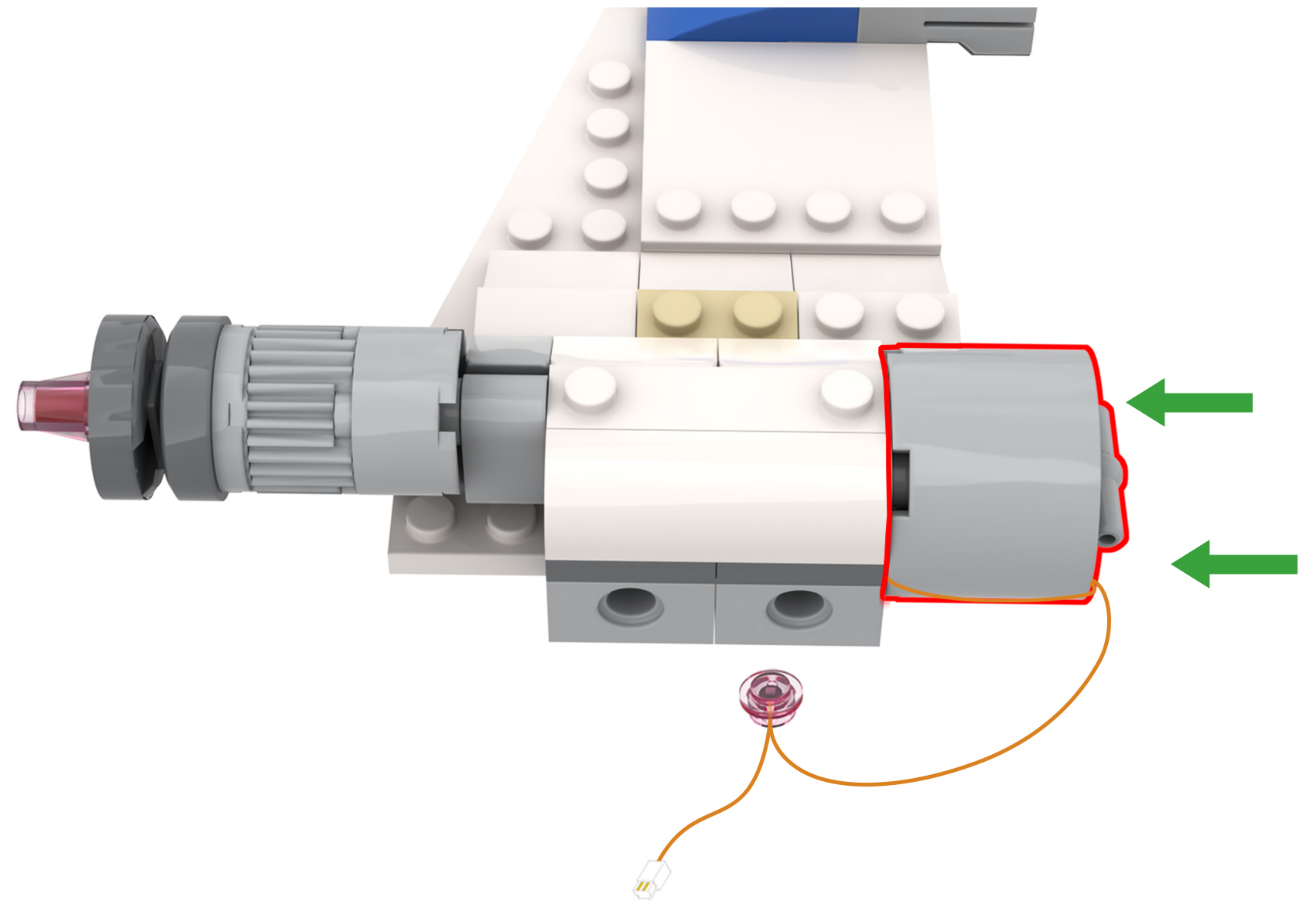
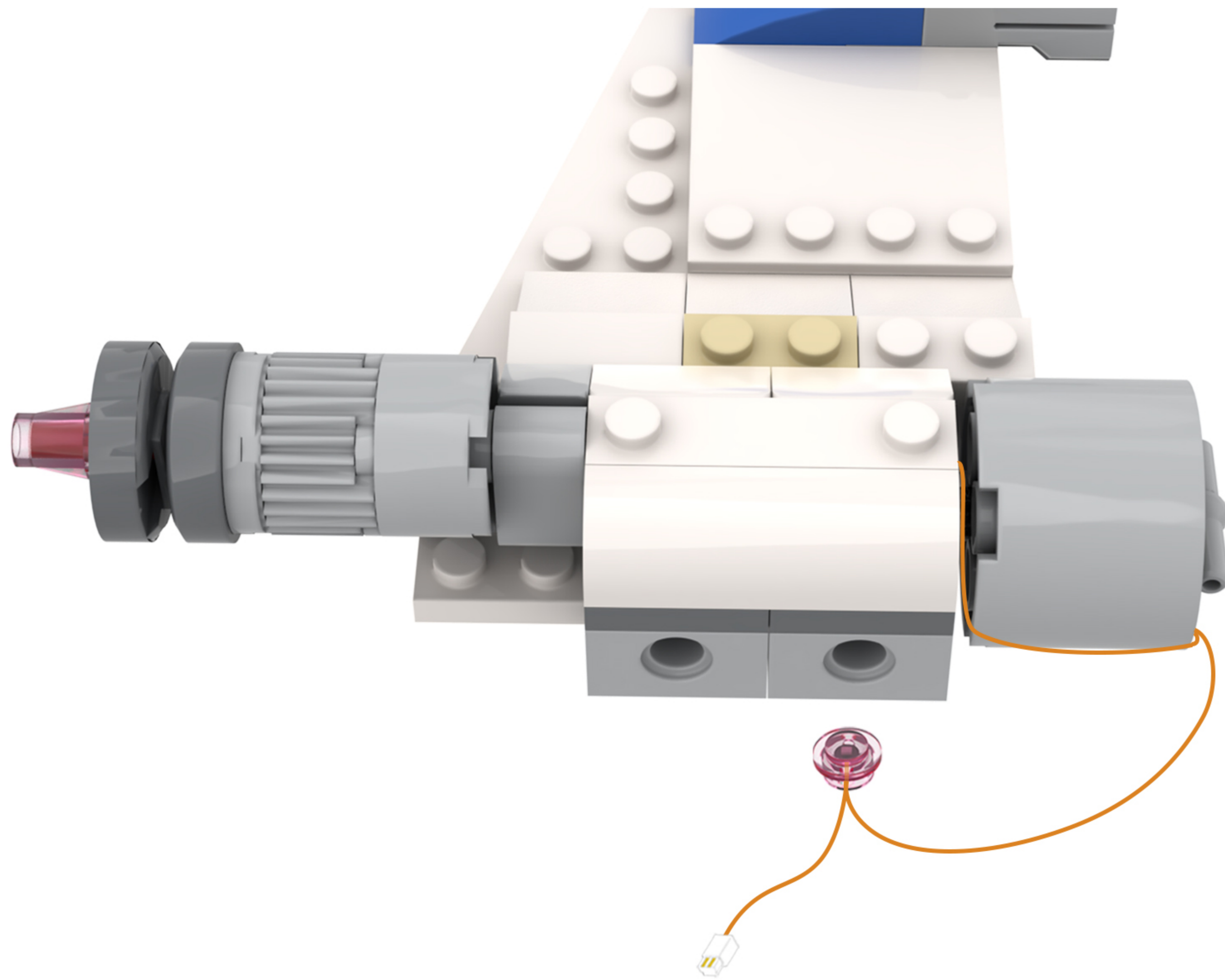

23

EN: Find the wire in the string of lights.

DE: Finde den Draht in der Lichterkette.

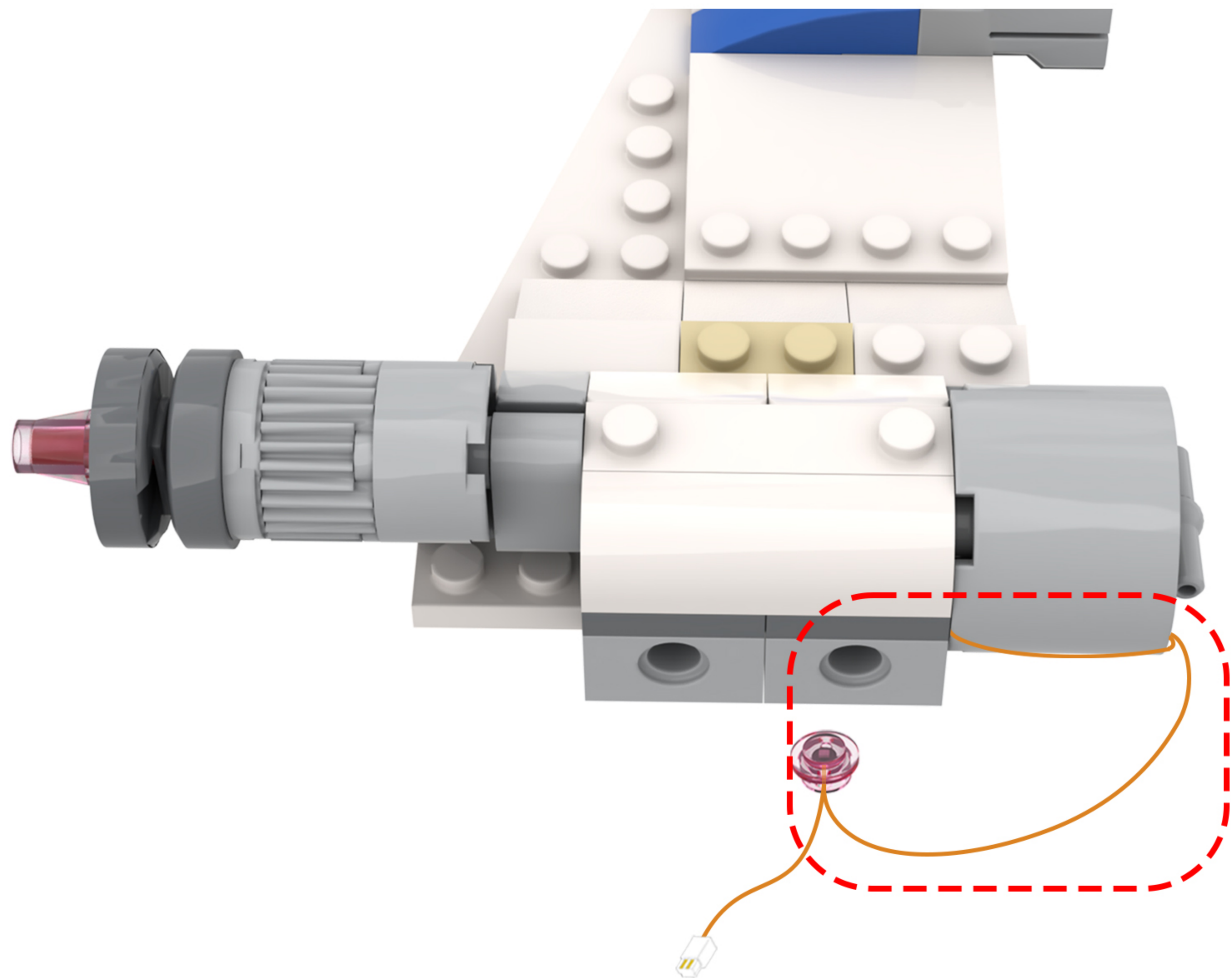

24

EN: Run the light cord from underneath the building block to the left.

DE: Führe das Lichtkabel unterhalb des Bausteins nach links.

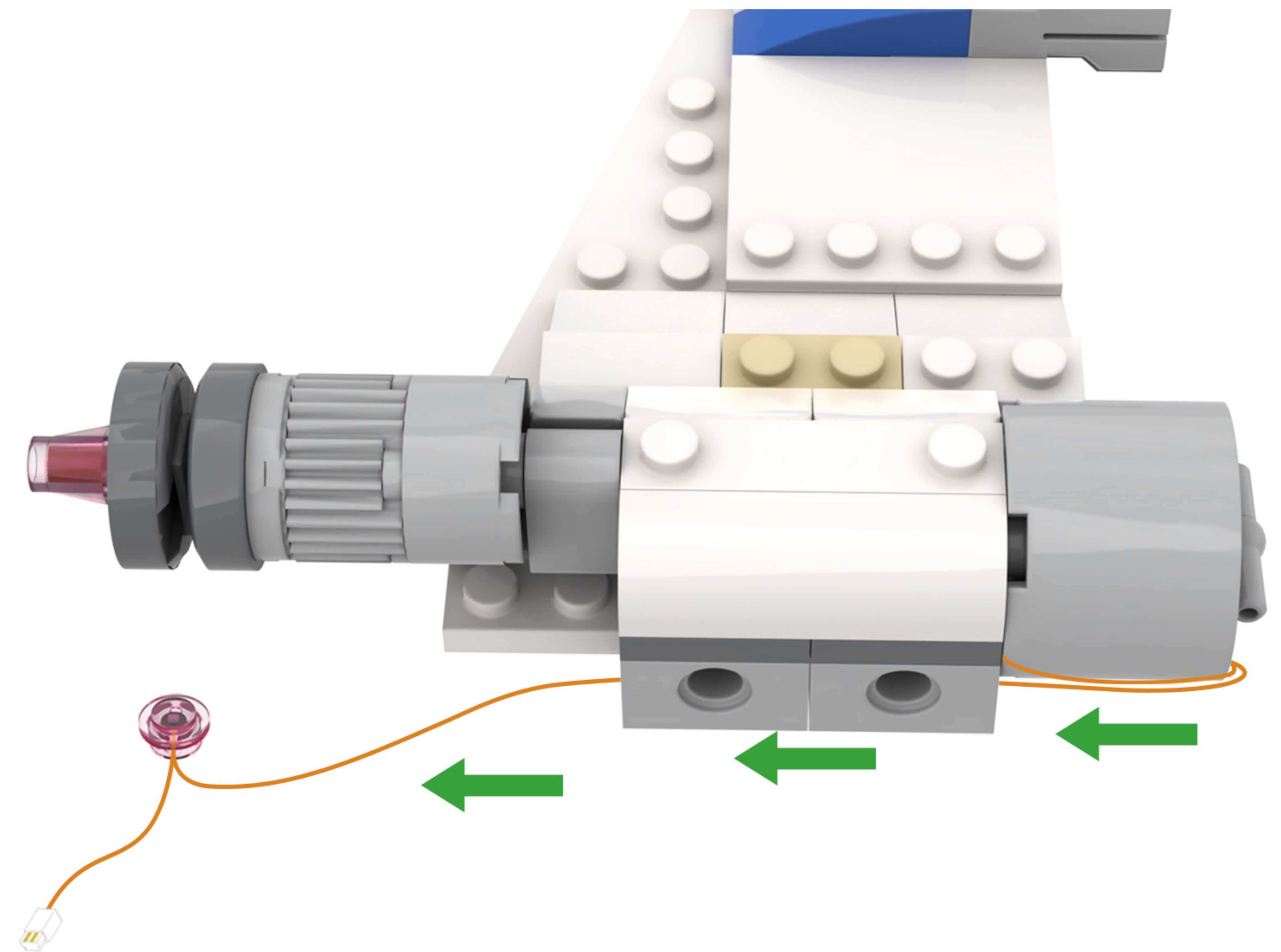

25

EN: Pull the building block out slightly.

DE: Zieh den Baustein ein wenig heraus.

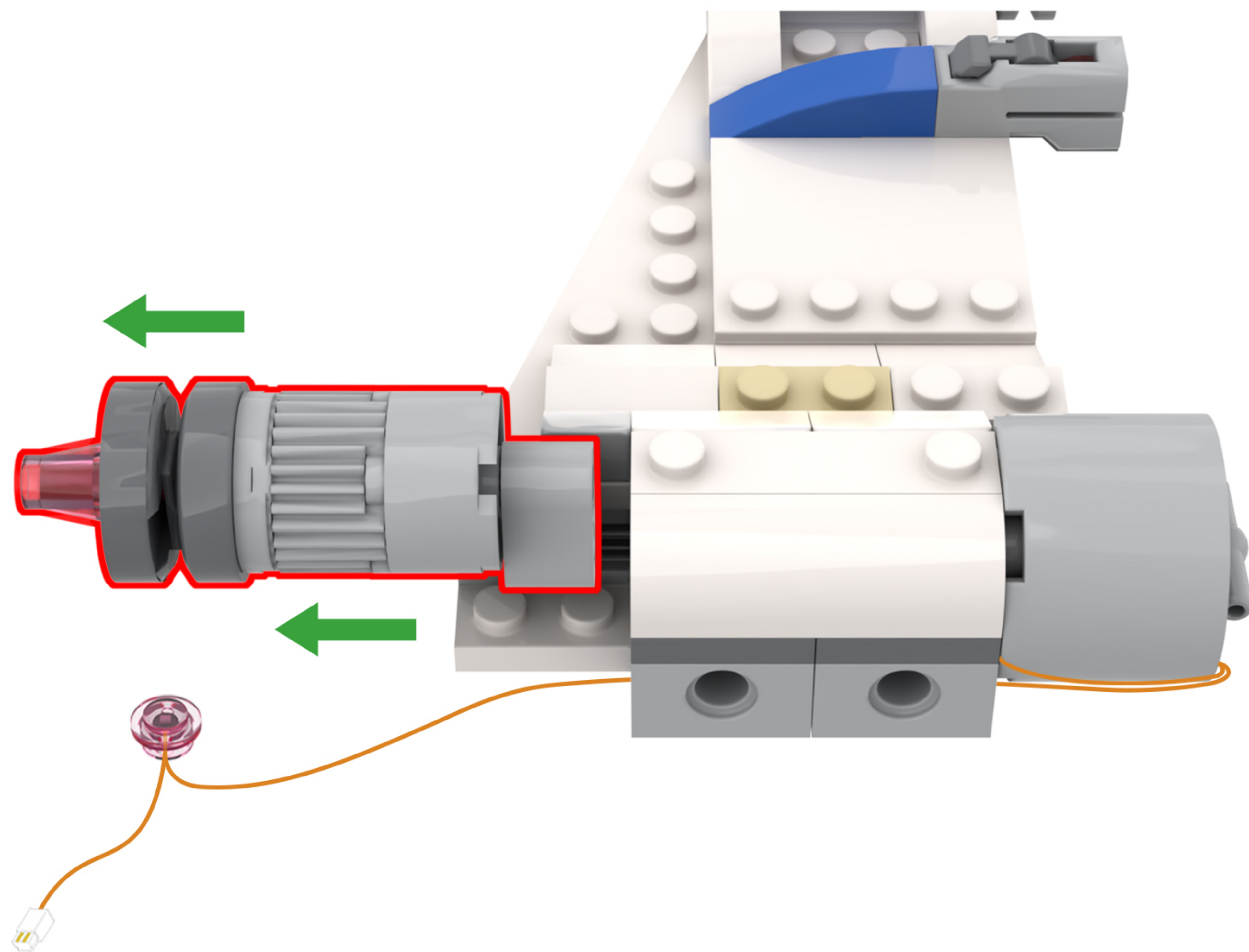

26

EN: Find the wire in the string of lights.

DE: Finde den Draht in der Lichterkette.

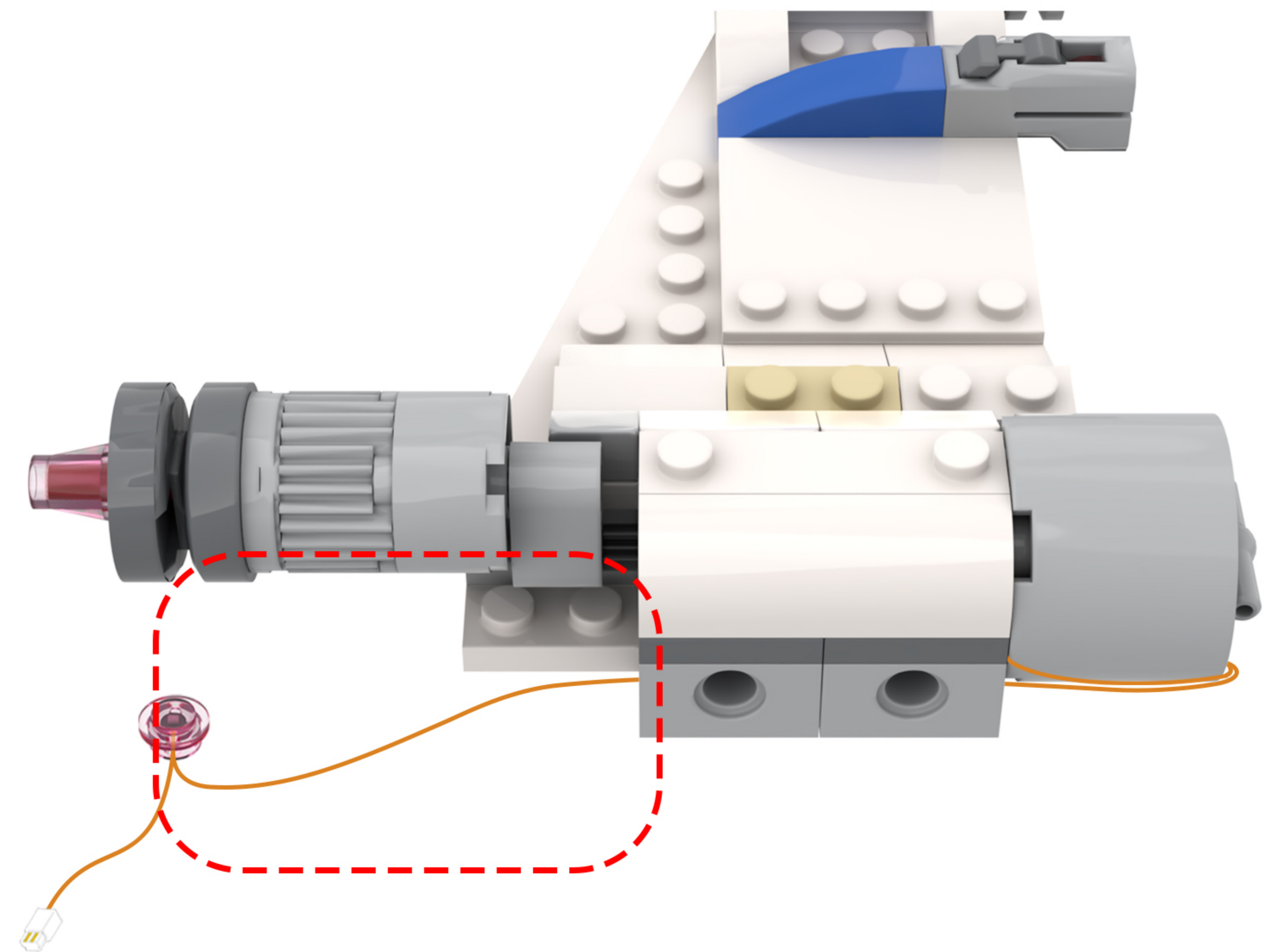

27

EN: Wrap the lamp cord around the crossbar twice.

DE: Wickeln Sie das Lampenkabel zweimal um die Querstange.

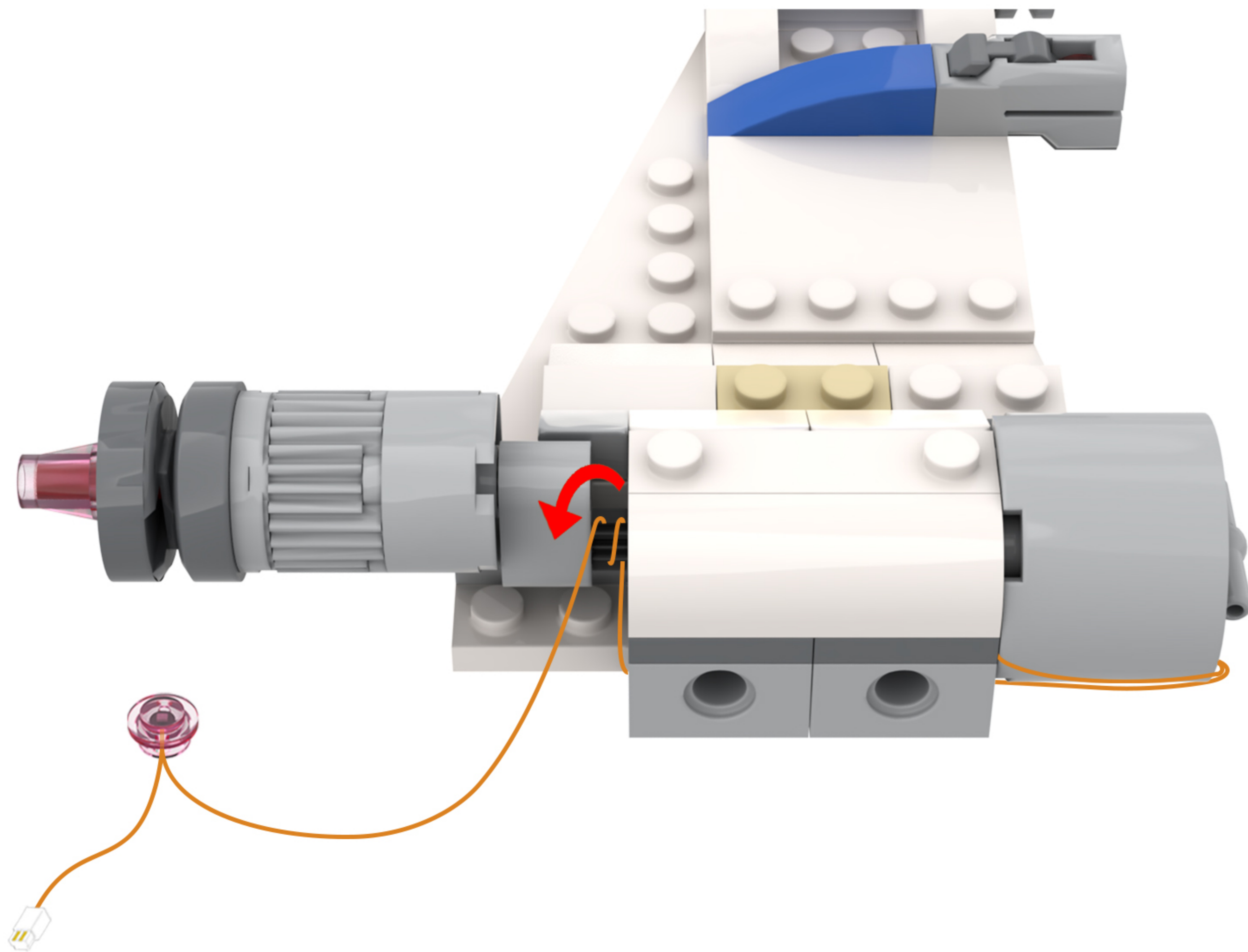

28

EN: Find the lights in the string of lights.

DE: Finde die Lichter in der Lichterkette.

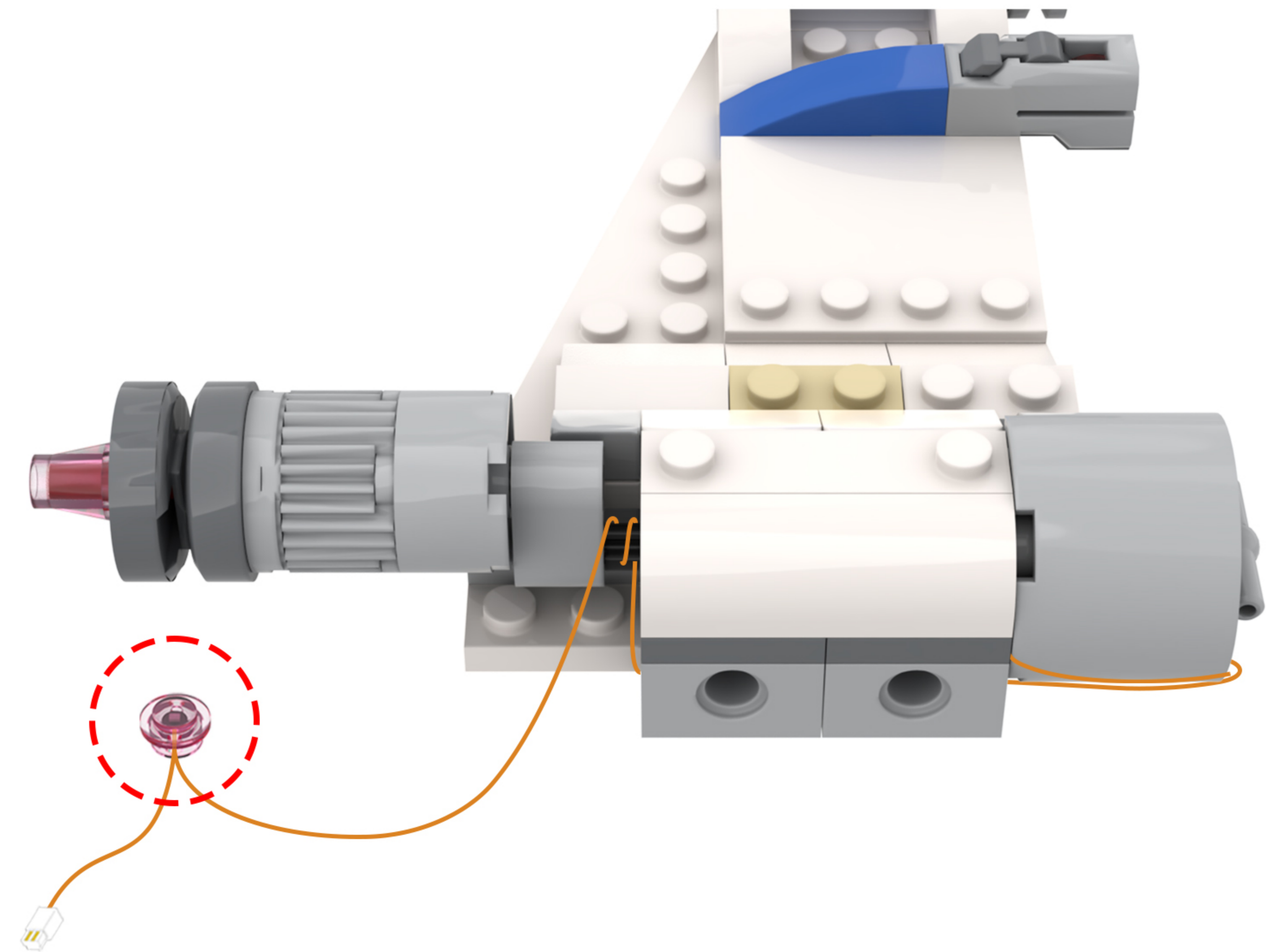

29

EN: Attach the lights from the string to the building blocks.

DE: Befestigen Sie die Lichter der Lichterkette an den Bausteinen.

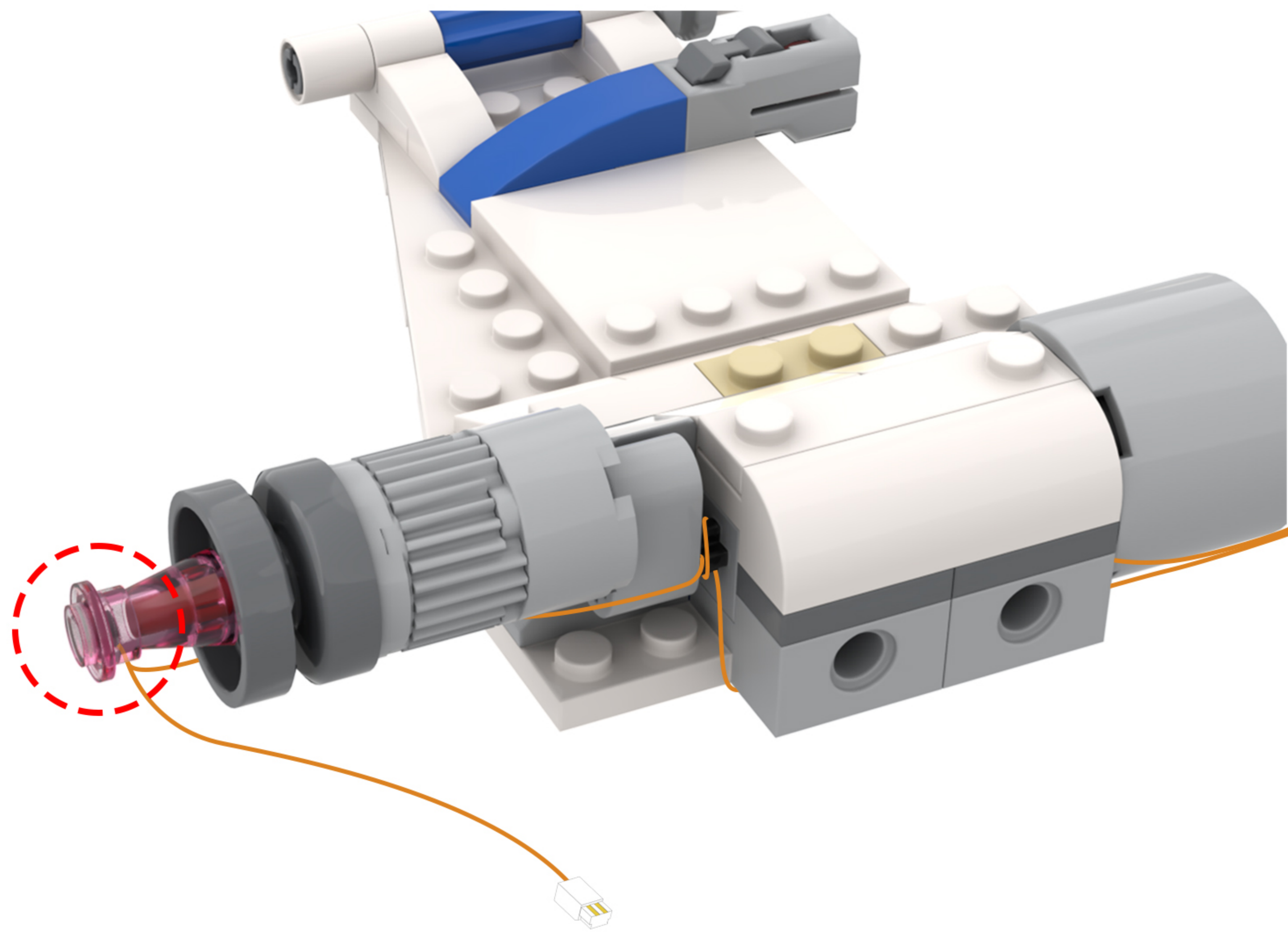

30

EN: Locate this light cord in the diagram.

DE: Suchen Sie dieses Lichtkabel in der Abbildung.

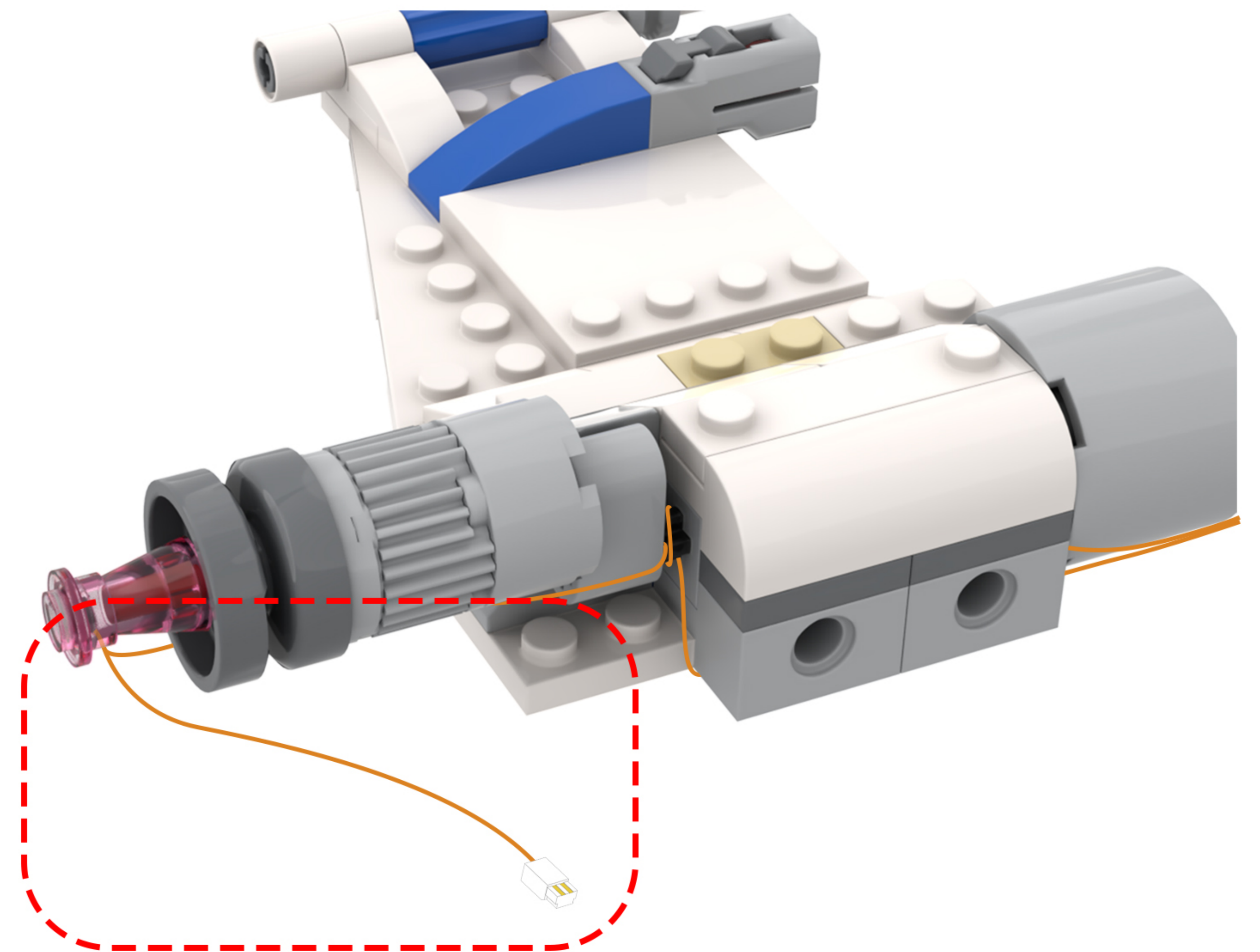

31

EN: Slide the light cord back into the gap in the building block.

DE: Schieben Sie das Lichtkabel wieder in den Spalt im Baustein.

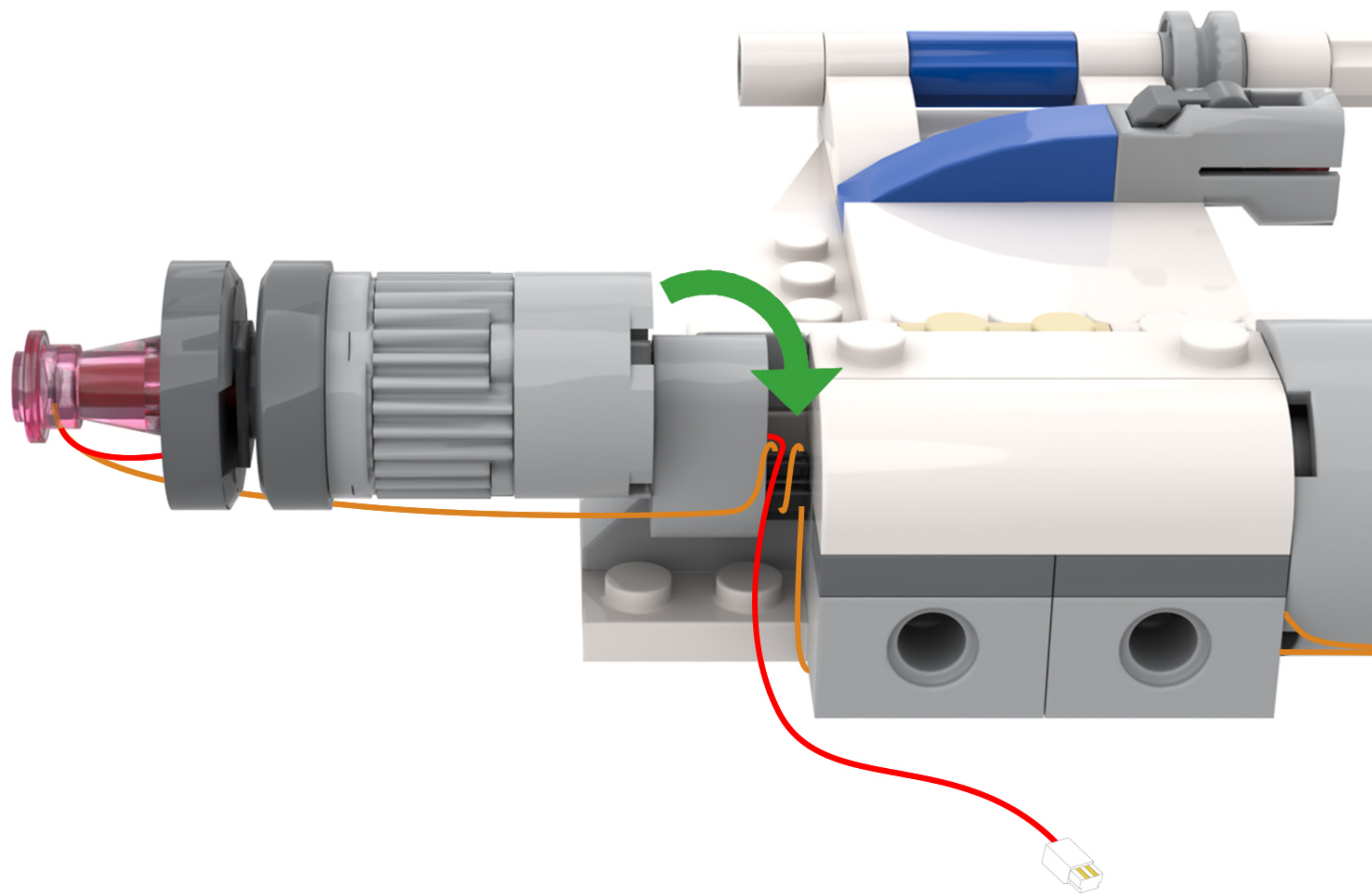

32

EN: Return the building blocks to their original positions so that they press down on the light cord.

DE: Bringen Sie die Bausteine wieder in ihre ursprüngliche Position, sodass sie auf das Lichtkabel drücken.

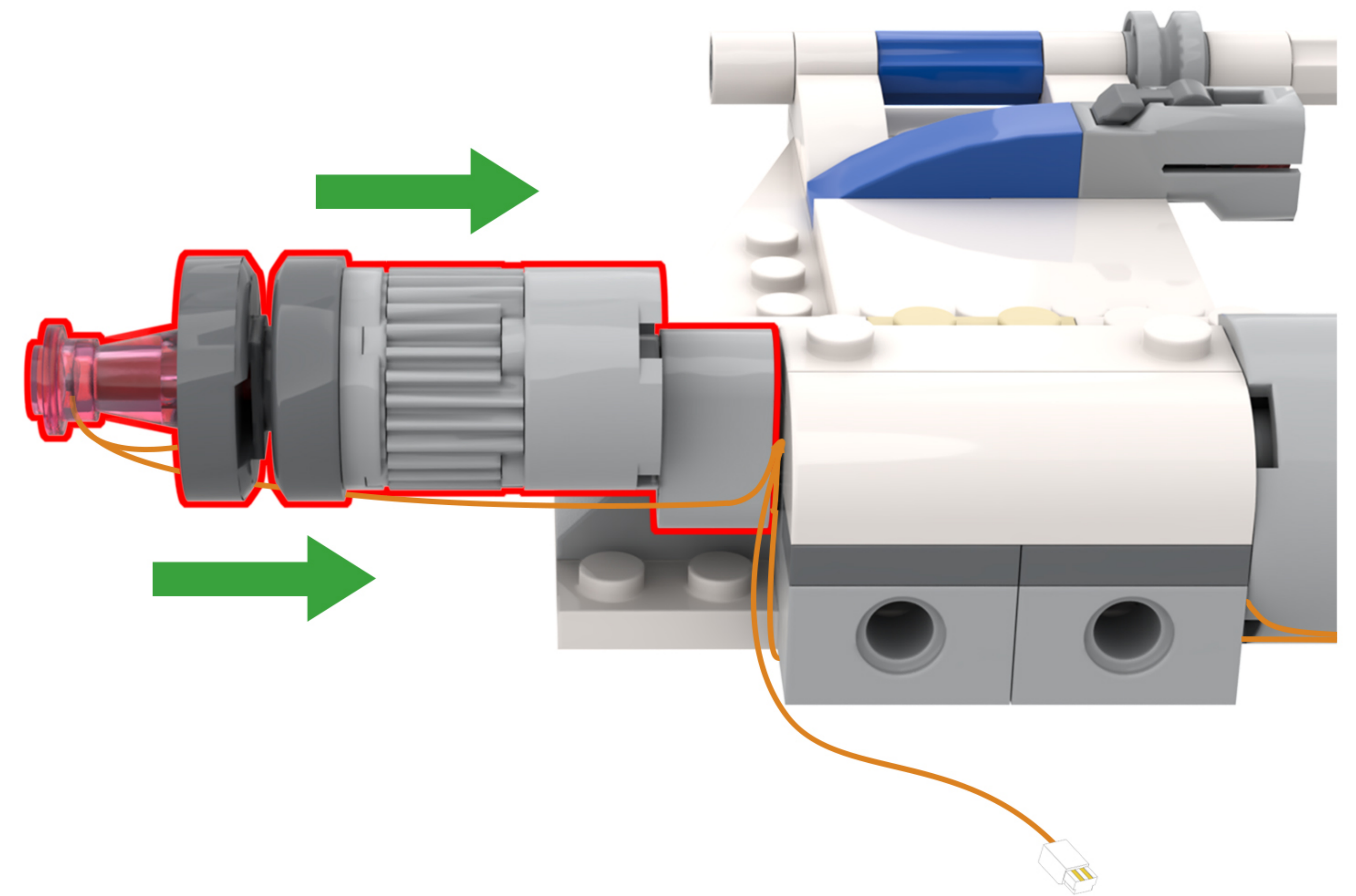

33

EN: The lighting fixtures have been installed on the building blocks.

DE: Die Leuchten wurden an den Gebäudeteilen angebracht.

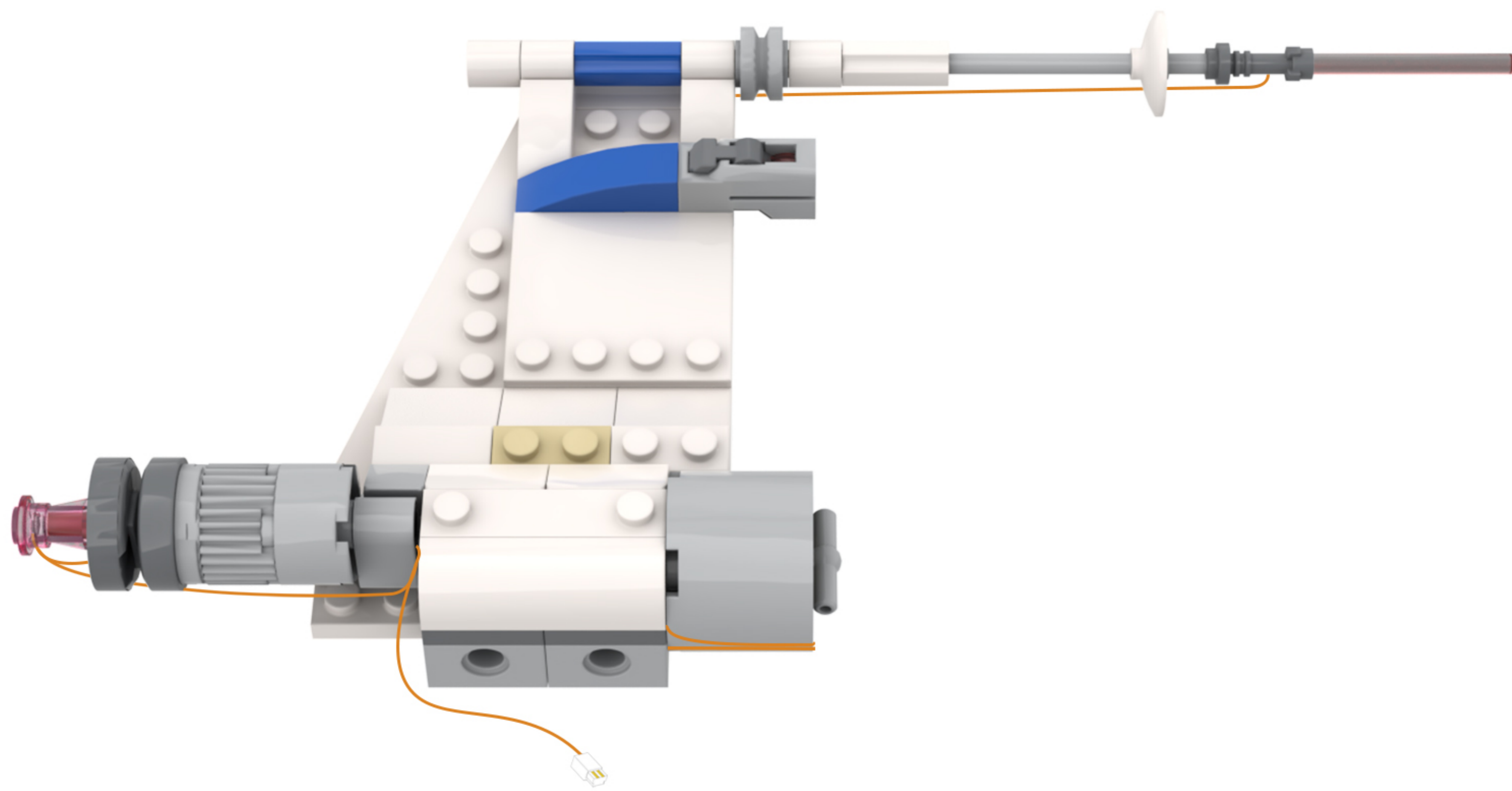

34

EN: Repeat the steps above to install lighting on the other building block.

DE: Wiederholen Sie die oben genannten Schritte, um die Beleuchtung am anderen Baustein anzubringen.

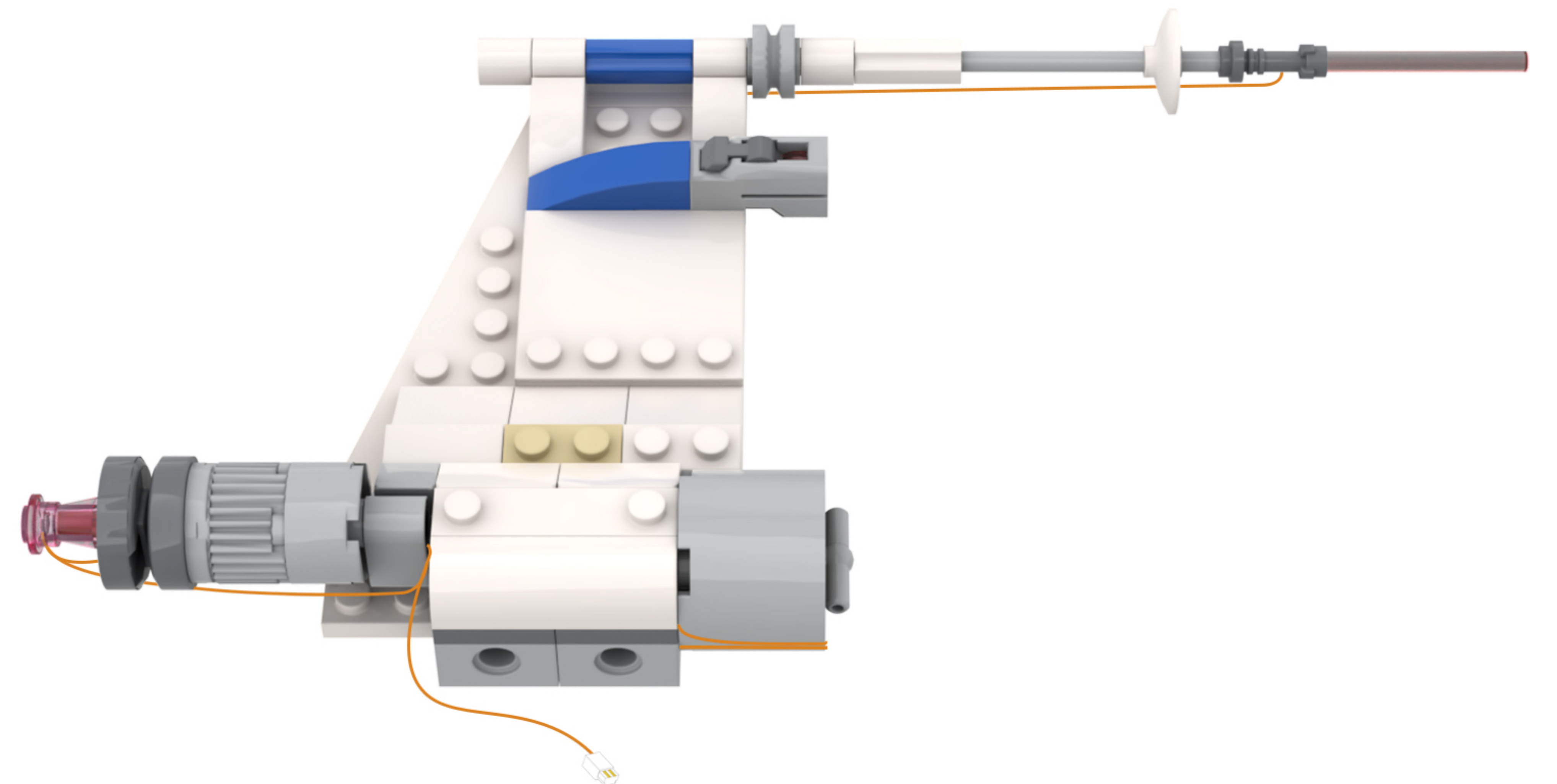
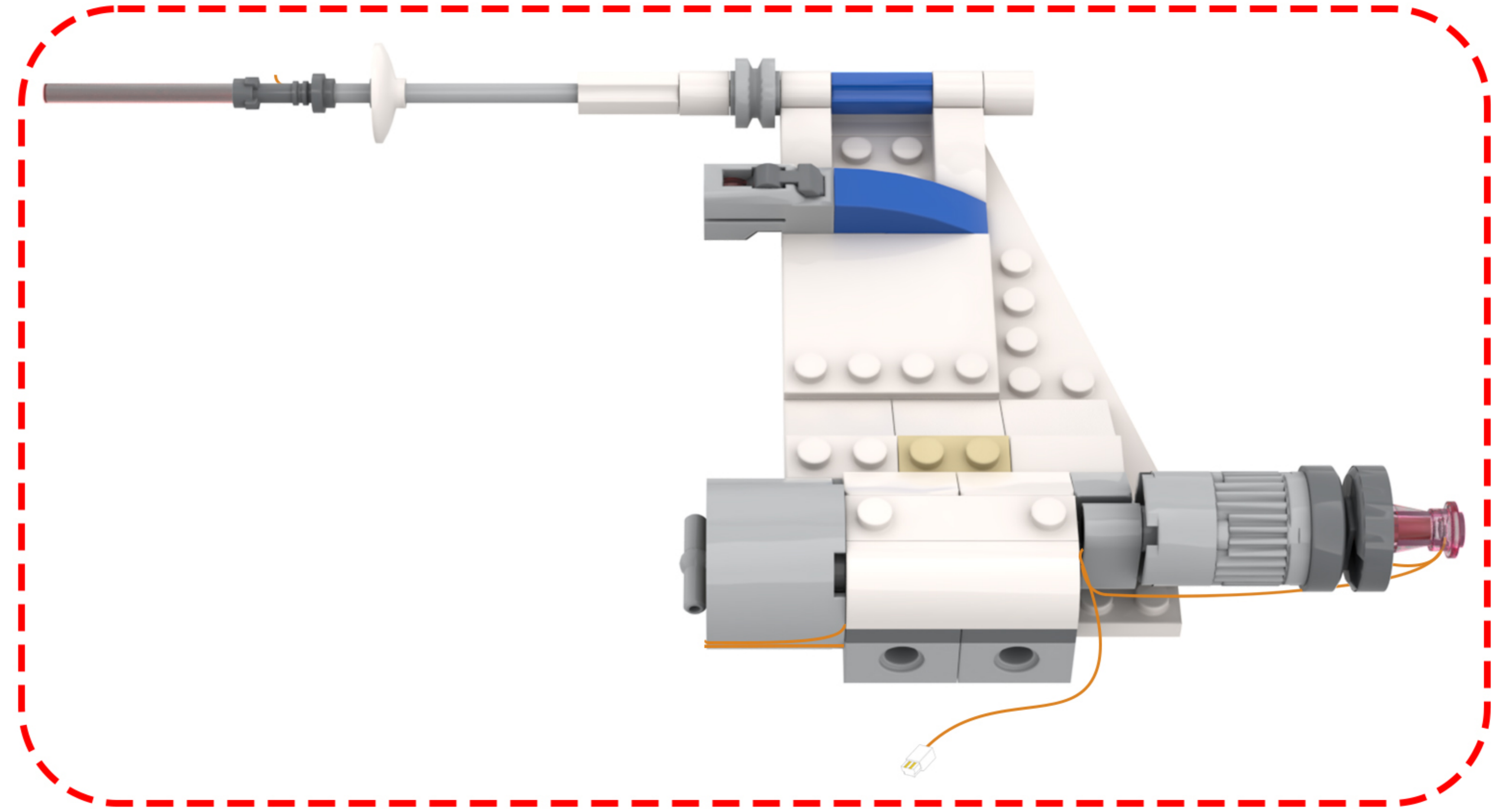

35

EN: Back to the model.

DE: Zurück zum Modell.

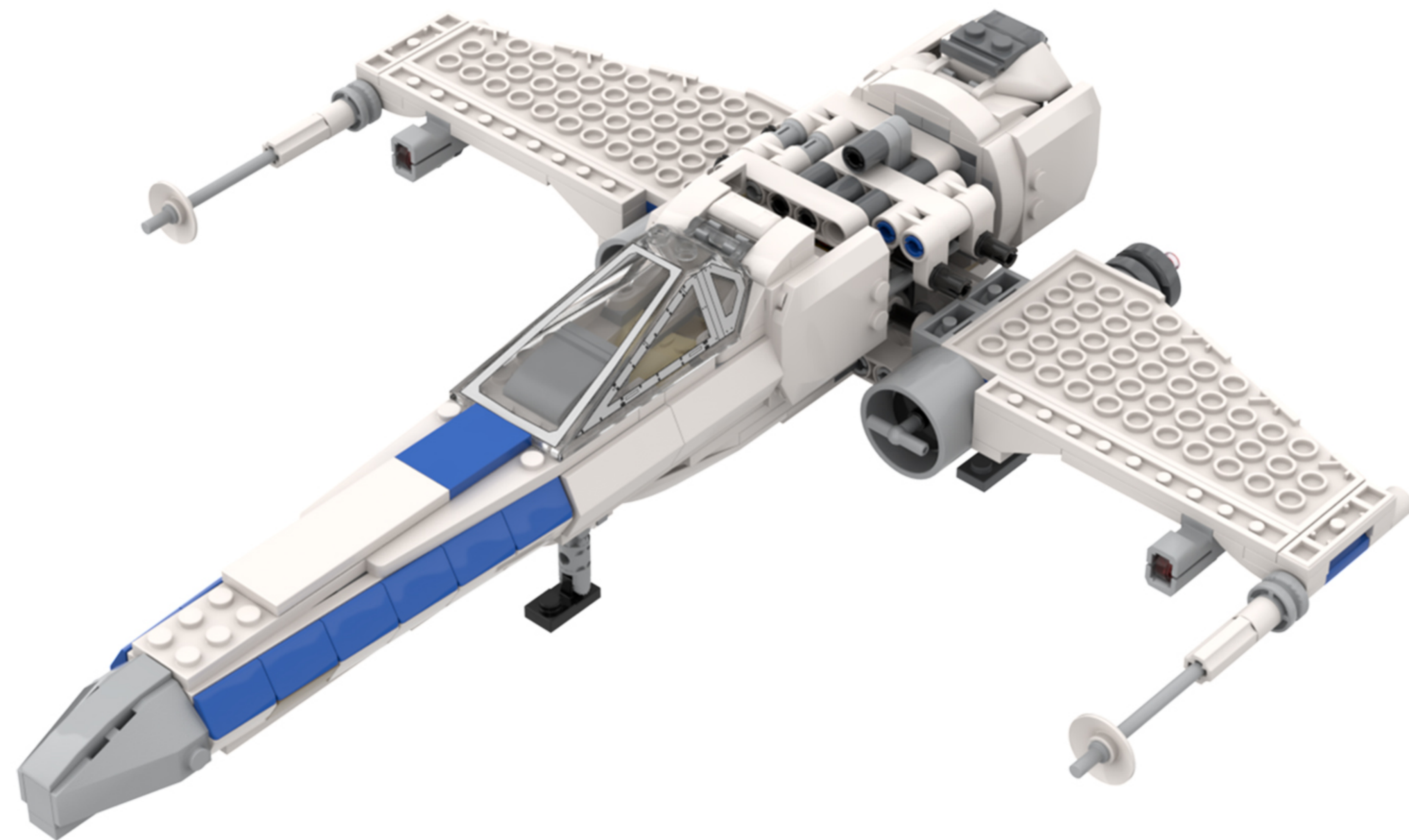

36

EN: Remove the building blocks one by one.

DE: Entfernen Sie die Bausteine nacheinander.

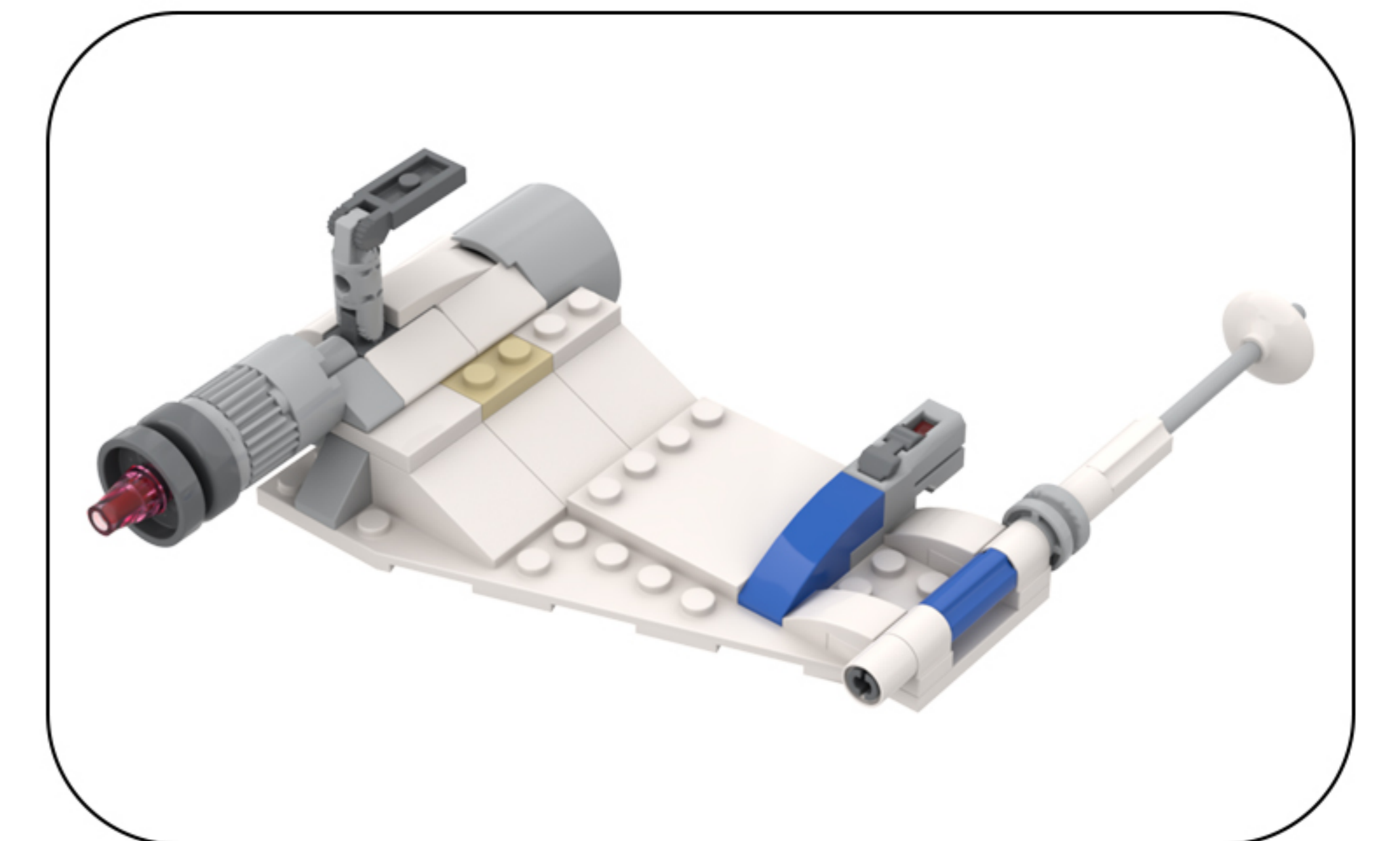
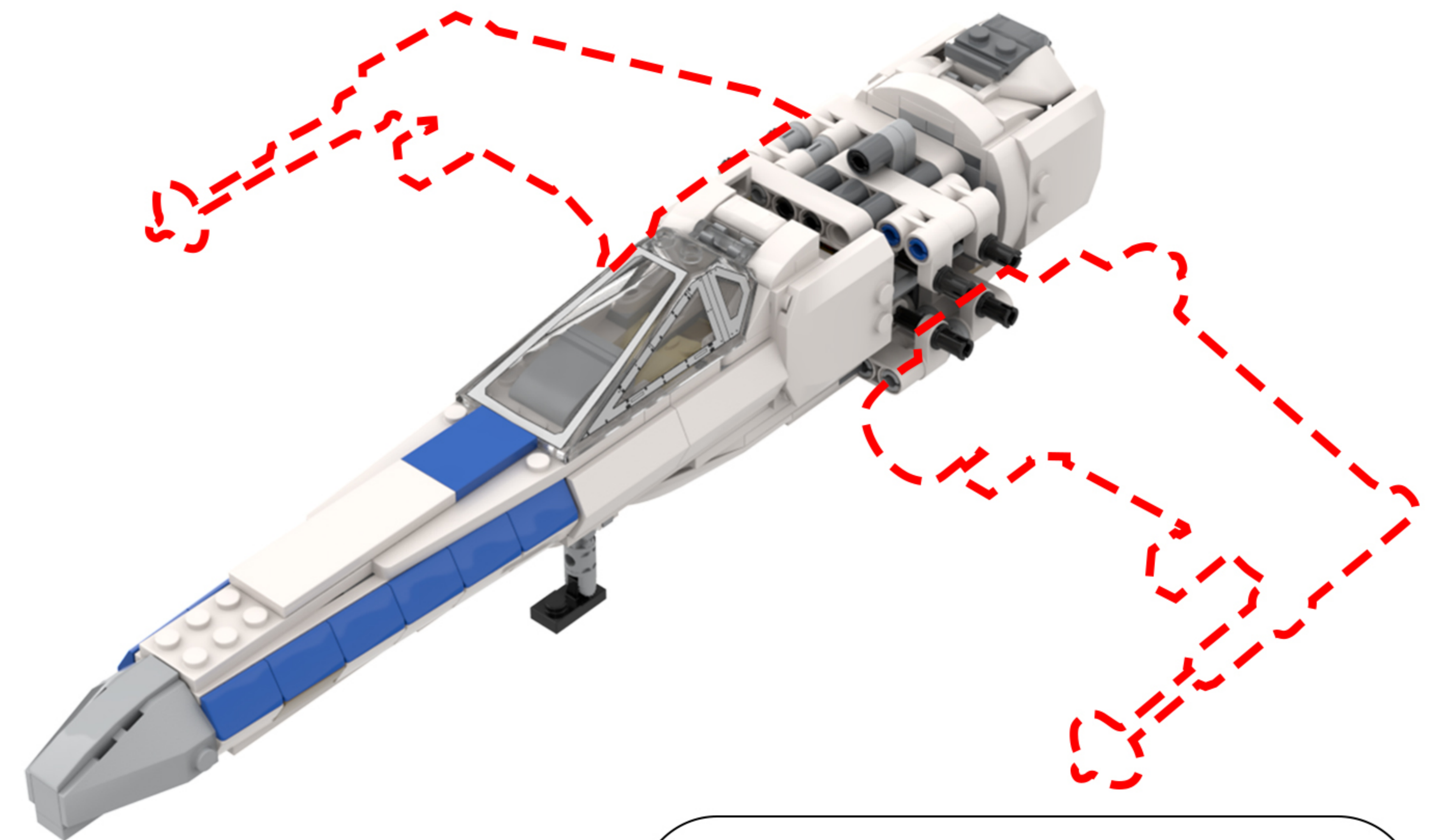
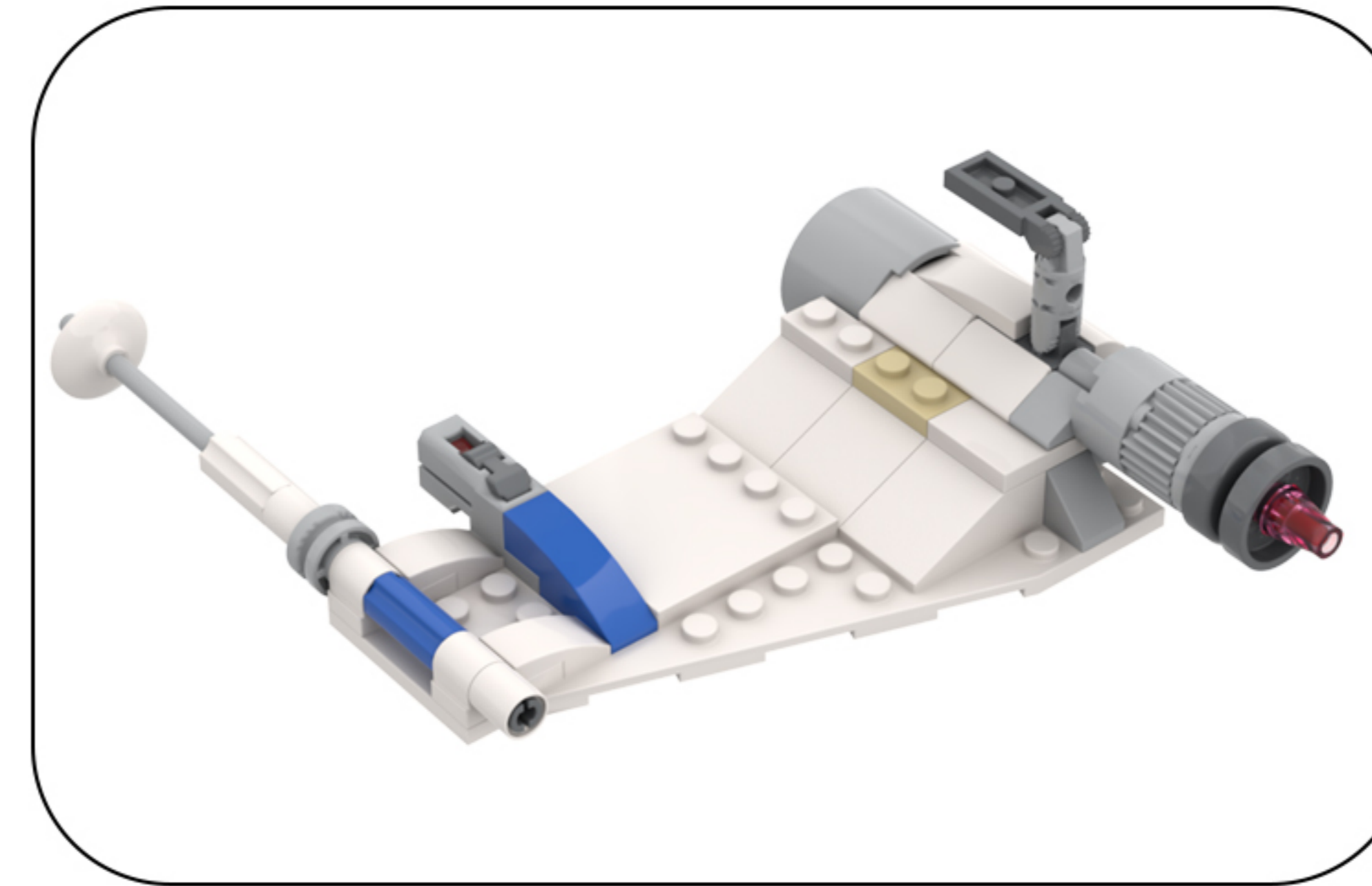

37

EN: Take out the following building blocks and the building blocks with the lights attached.

DE: Nimm die folgenden Bausteine und die Bausteine mit den daran befestigten Lichtern heraus.

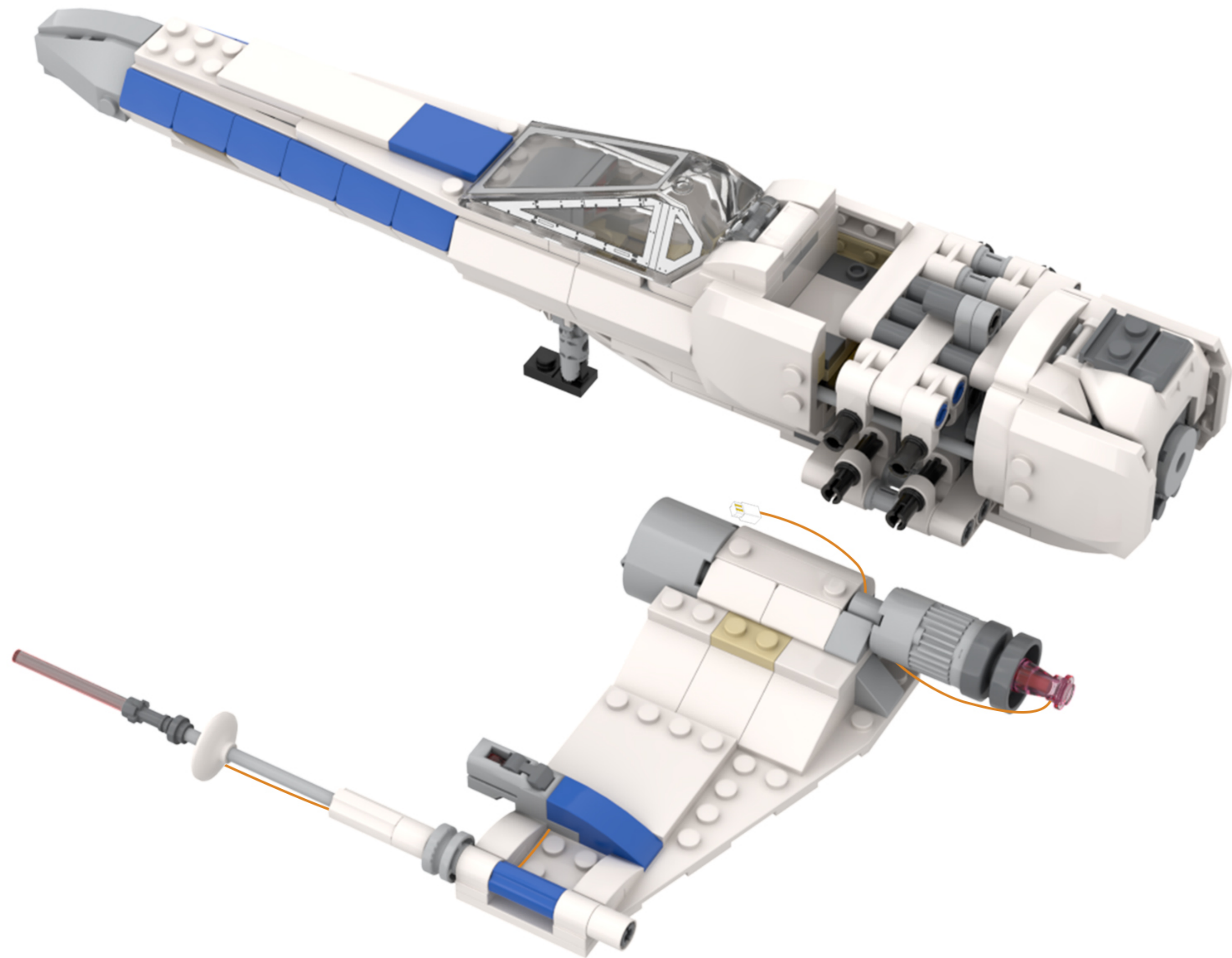

38

EN: Thread the lamp cord through the gaps in the building blocks.

DE: Führen Sie das Lampenkabel durch die Lücken in den Bausteinen.

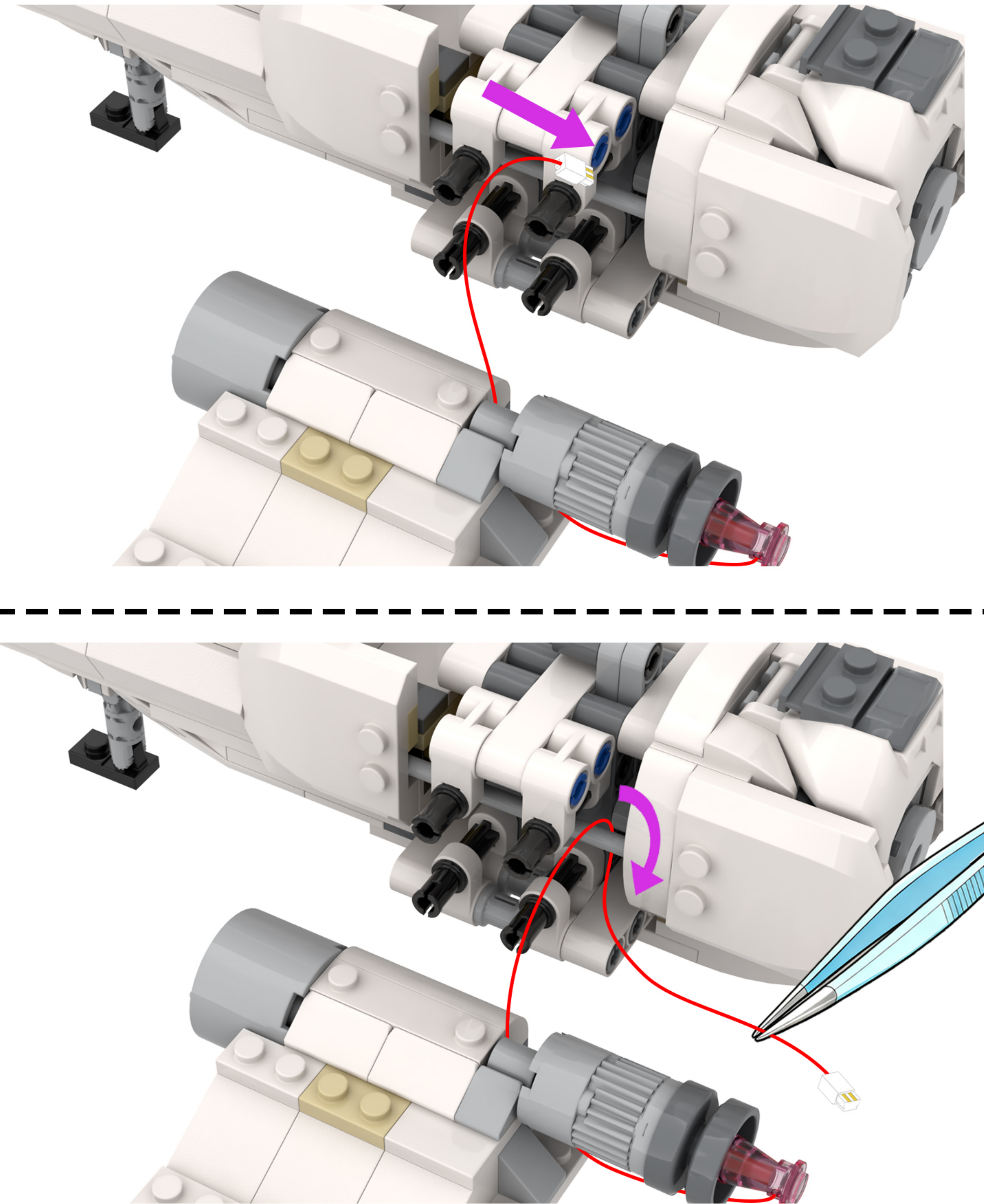

39

EN: Restore the building blocks.

DE: Stellen Sie die Bausteine wieder her.

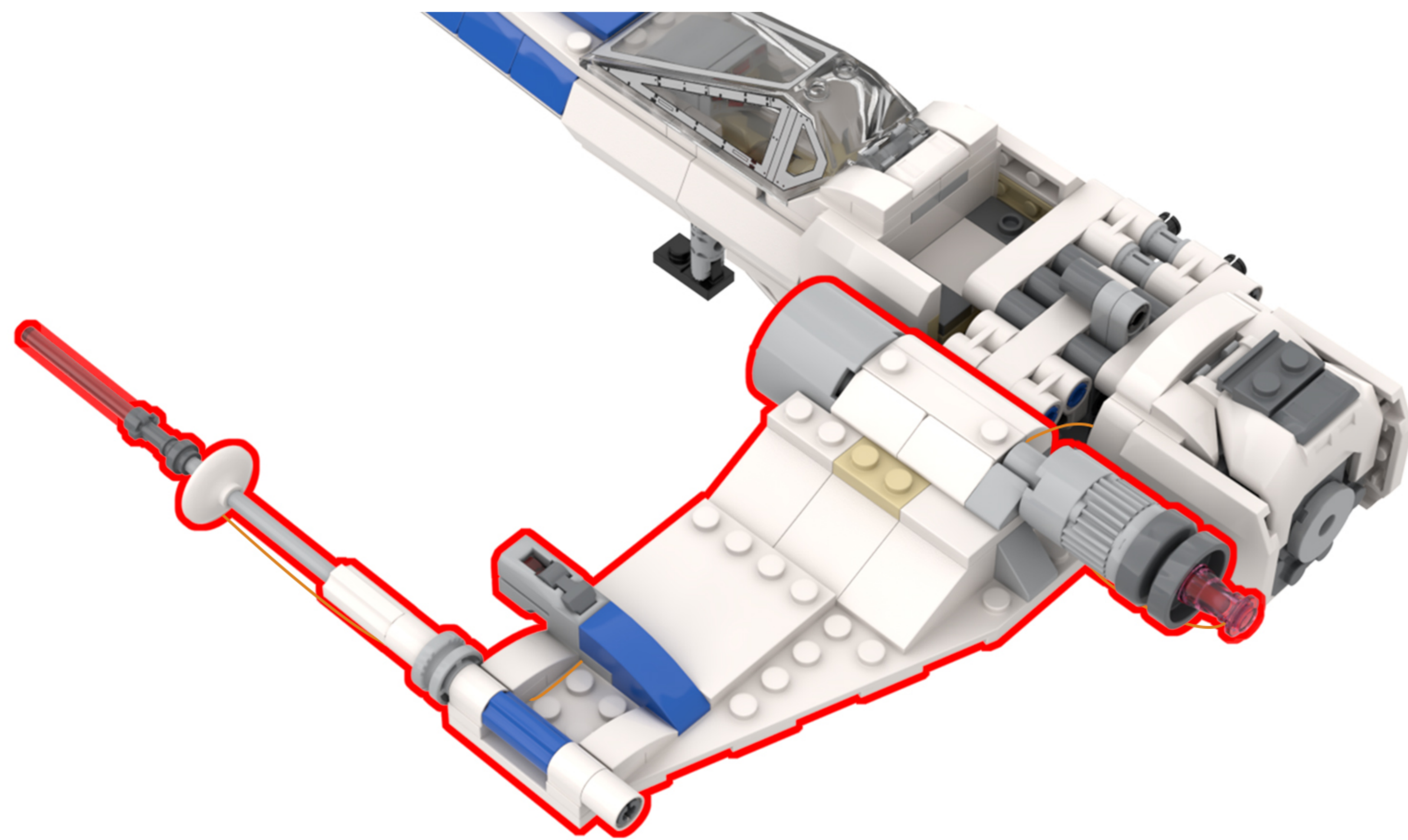

40

EN: Go to the other side of the model and take out another brick with the lights attached.

DE: Geh auf die andere Seite des Modells und nimm einen weiteren Baustein mit den daran befestigten Lichtern heraus.

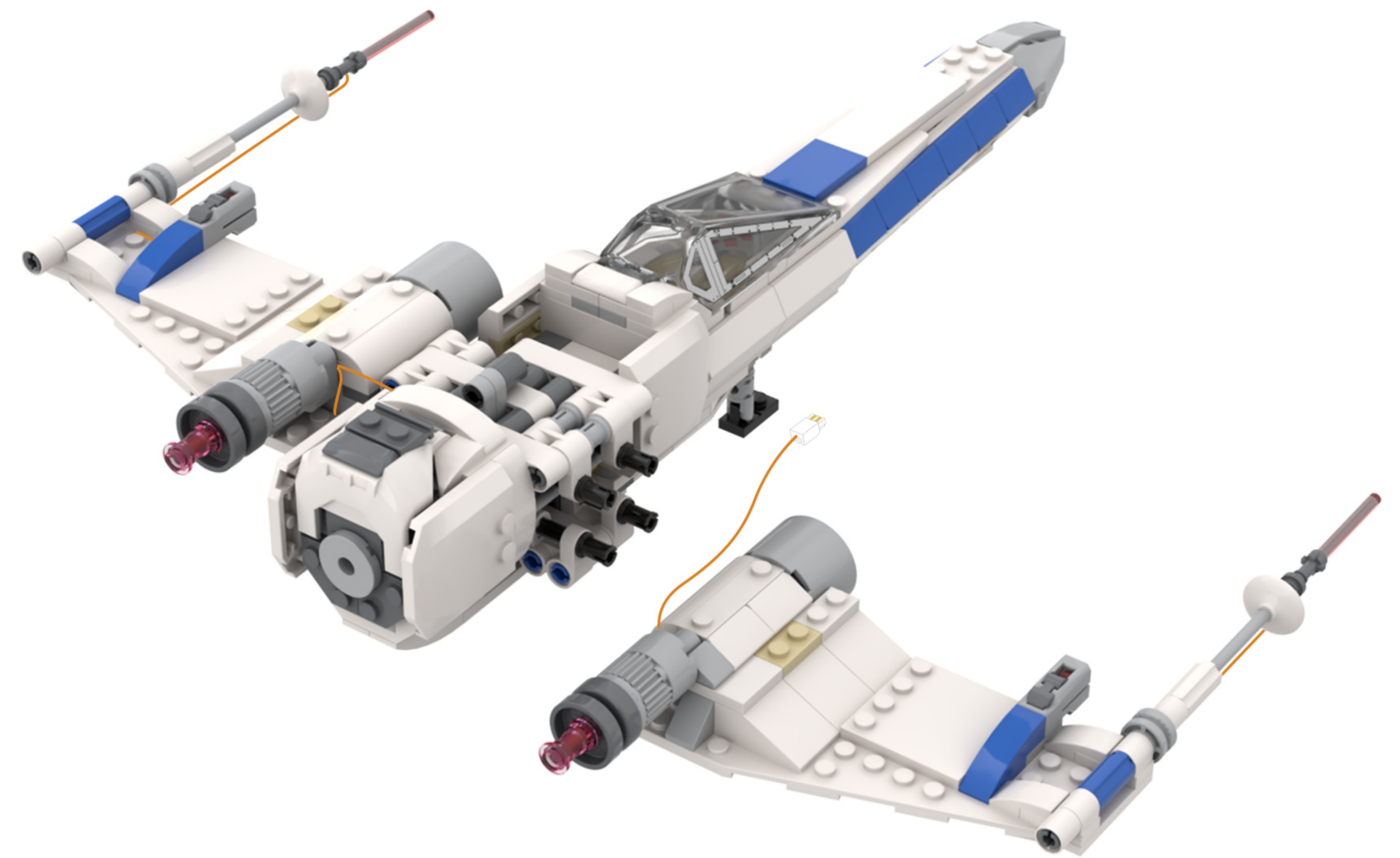

41

EN: Thread the lamp cord through the gaps in the building blocks.

DE: Führen Sie das Lampenkabel durch die Lücken in den Bausteinen.

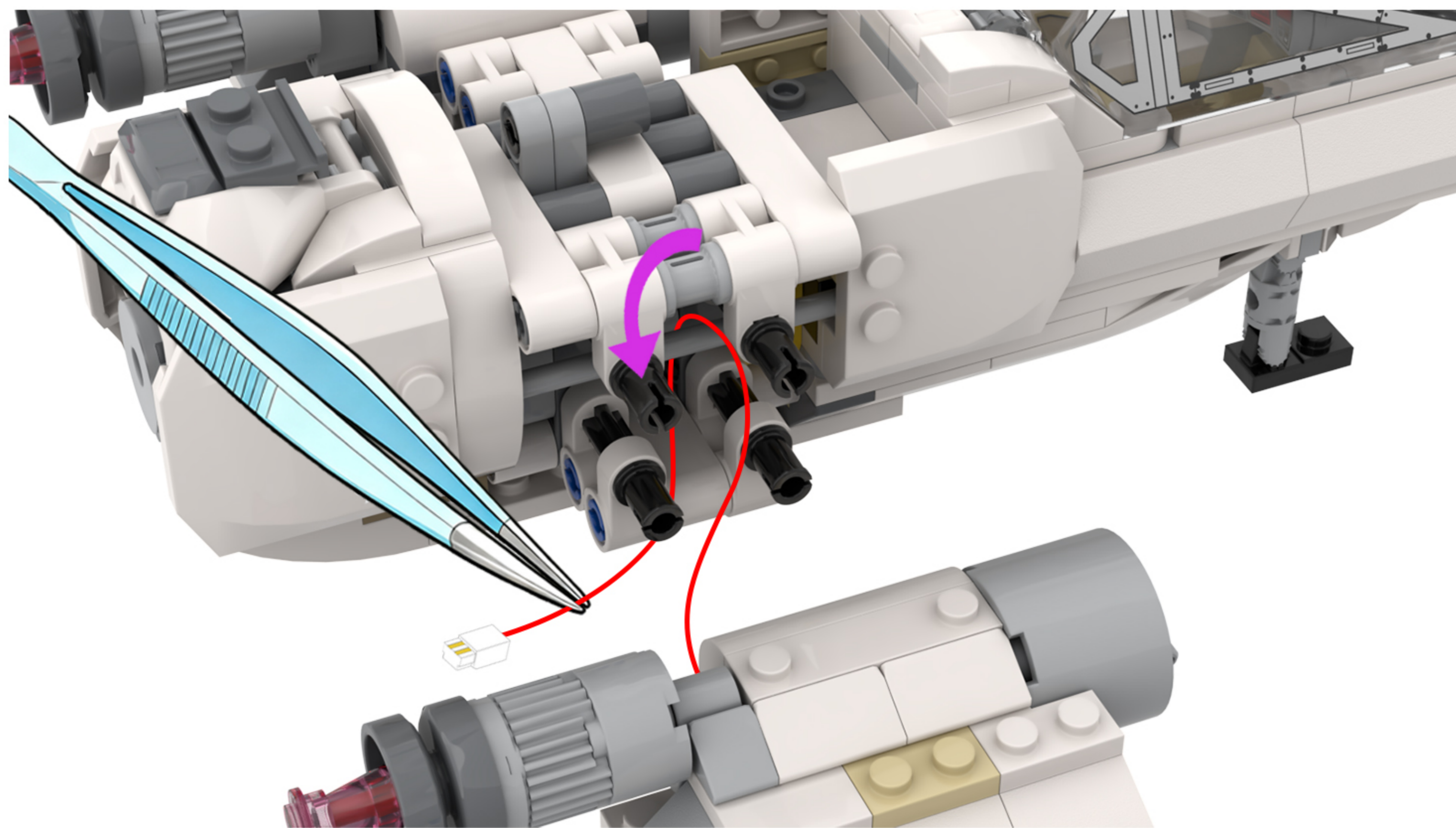
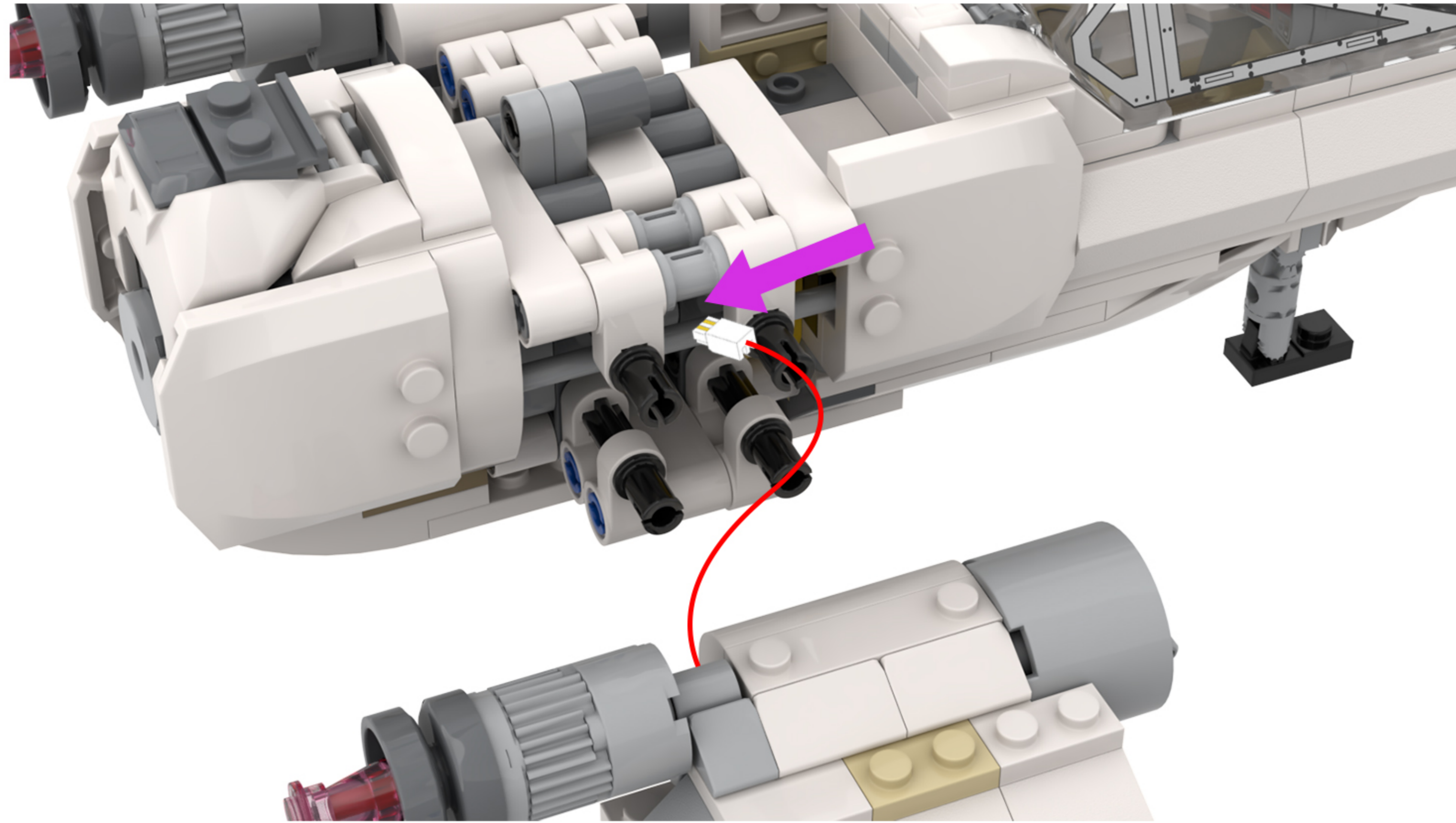

42

EN: Restore the building blocks.

DE: Stellen Sie die Bausteine wieder her.

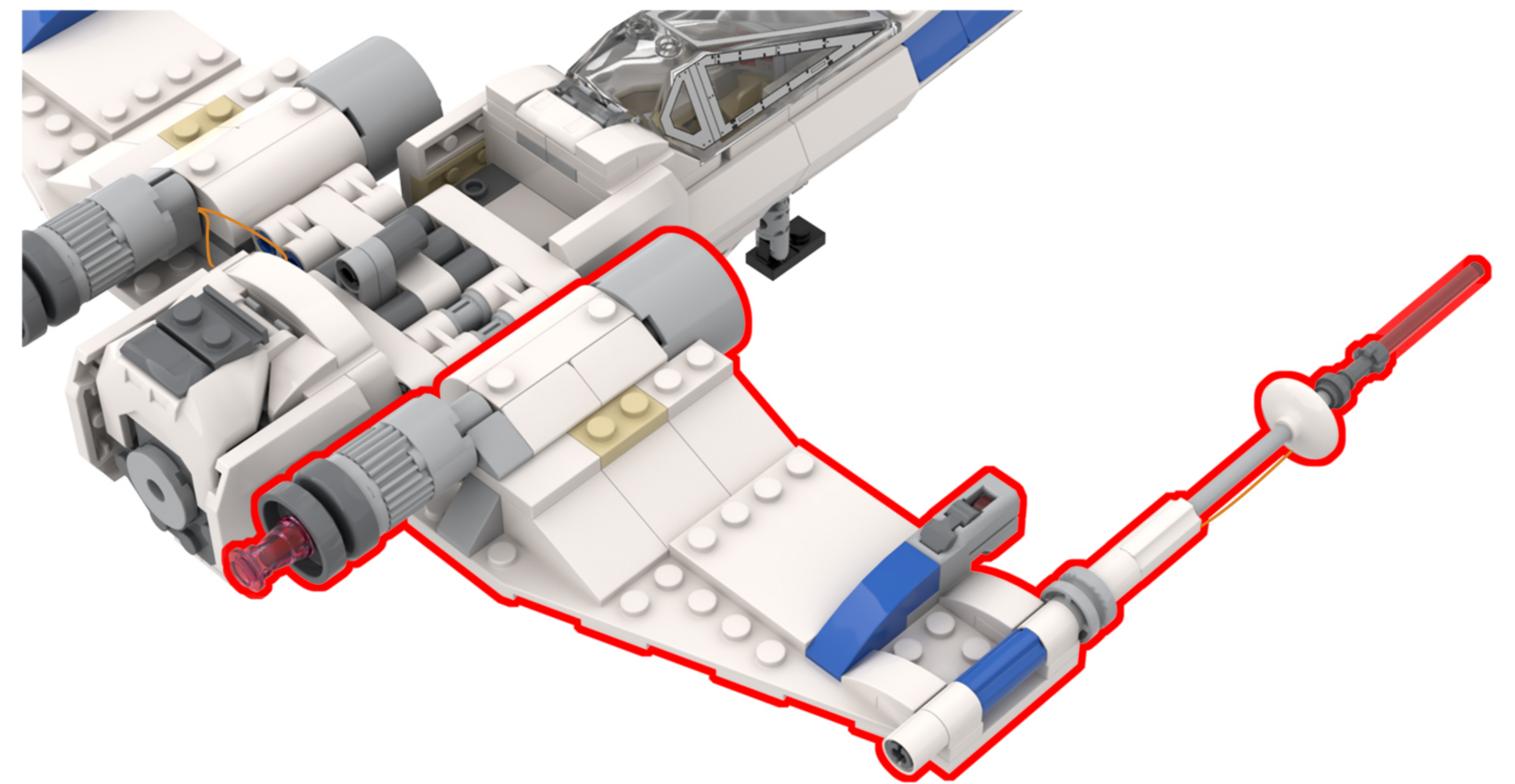

**43**

EN: Take the two disassembled building blocks; they have the same lighting fixtures. Let's use the one on the right as an example.

DE: Nehmen Sie die beiden zerlegten Bausteine; sie verfügen über die gleichen Beleuchtungskörper. Nehmen wir den rechten als Beispiel.

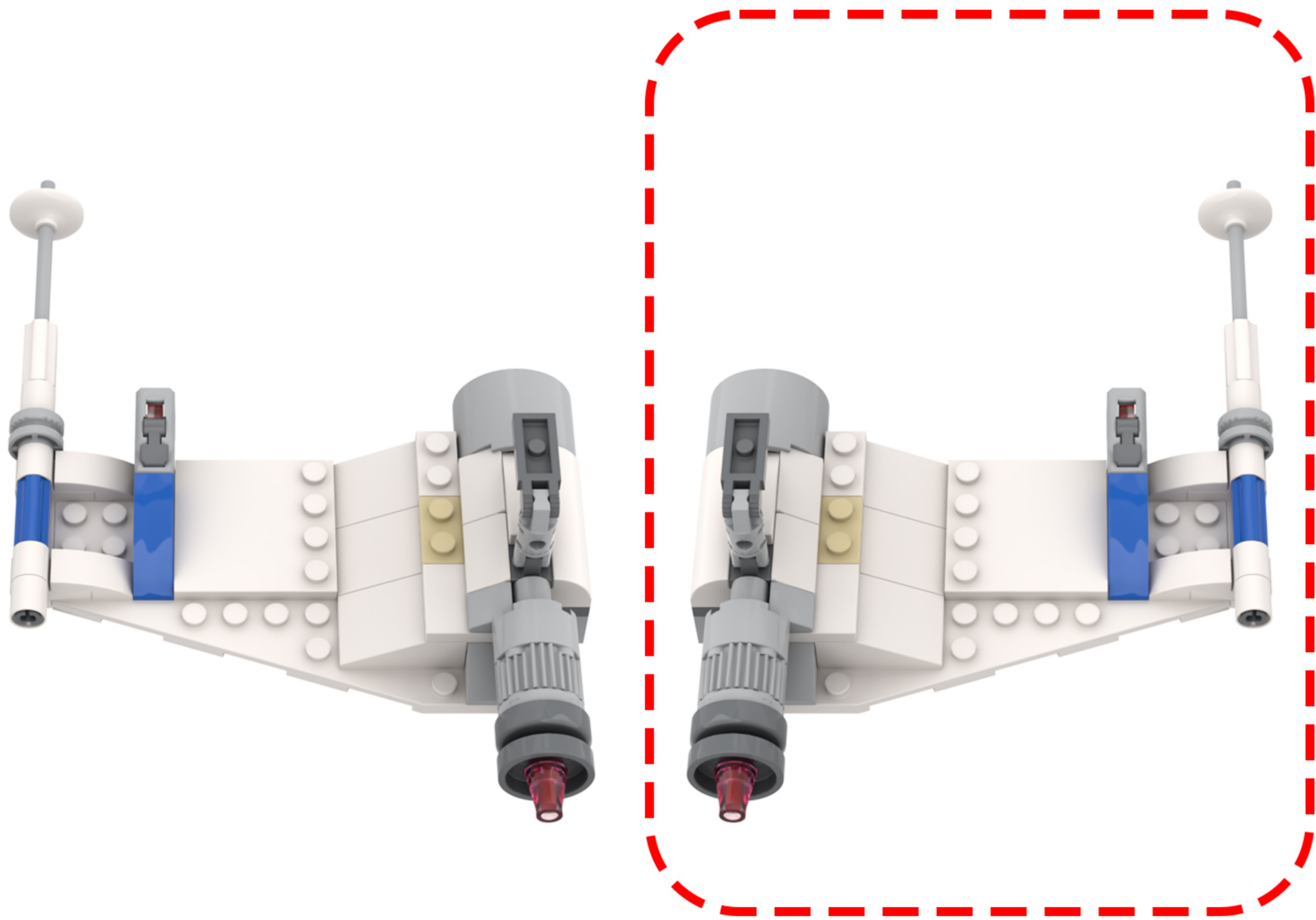
**44**

EN: Remove the building blocks one by one.

DE: Entfernen Sie die Bausteine nacheinander.

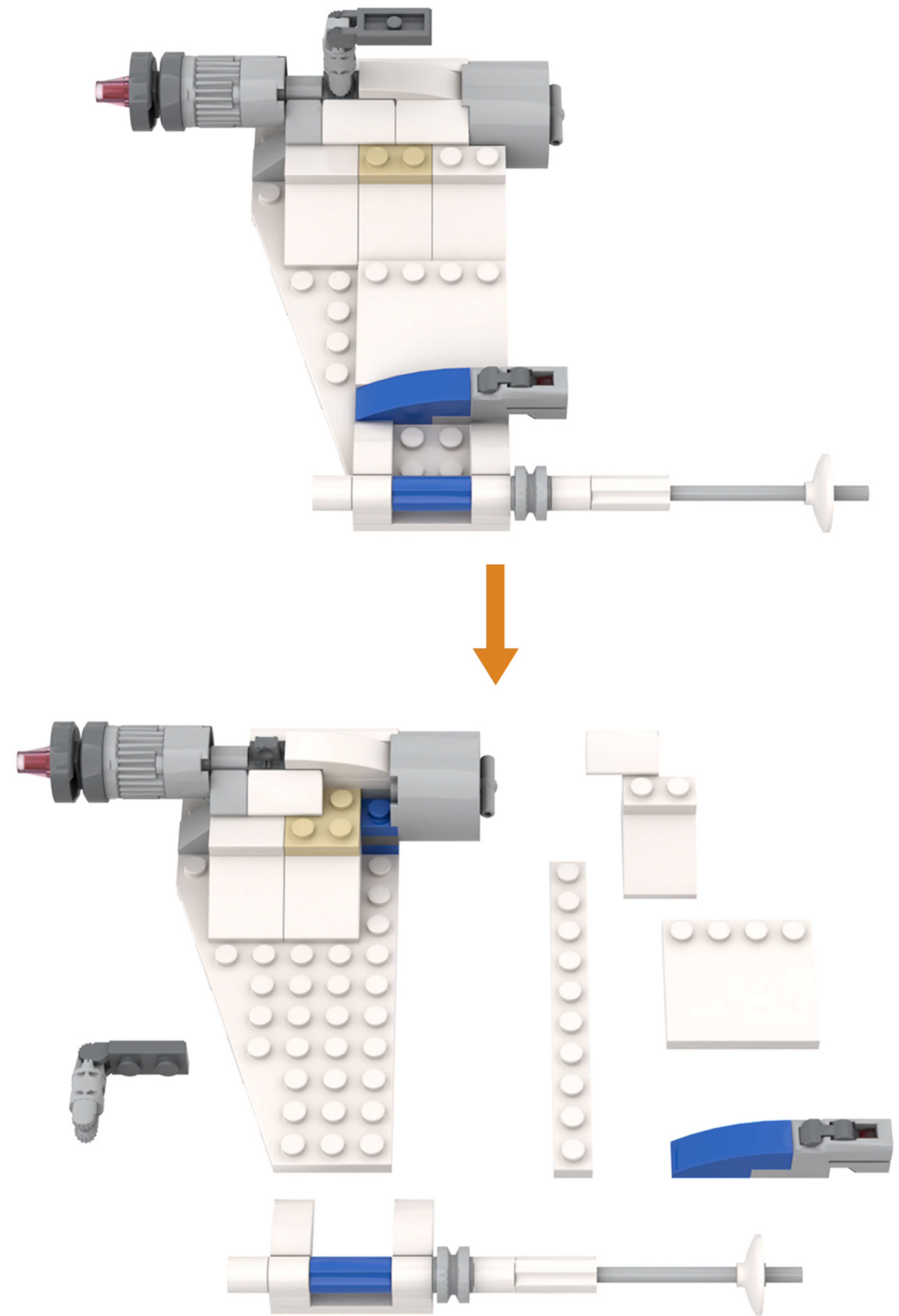

45

EN: Take out the string of lights from Bag 2 and the disassembled building blocks.

DE: Nimm die Lichterkette aus Beutel 2 und die zerlegten Bausteine heraus.

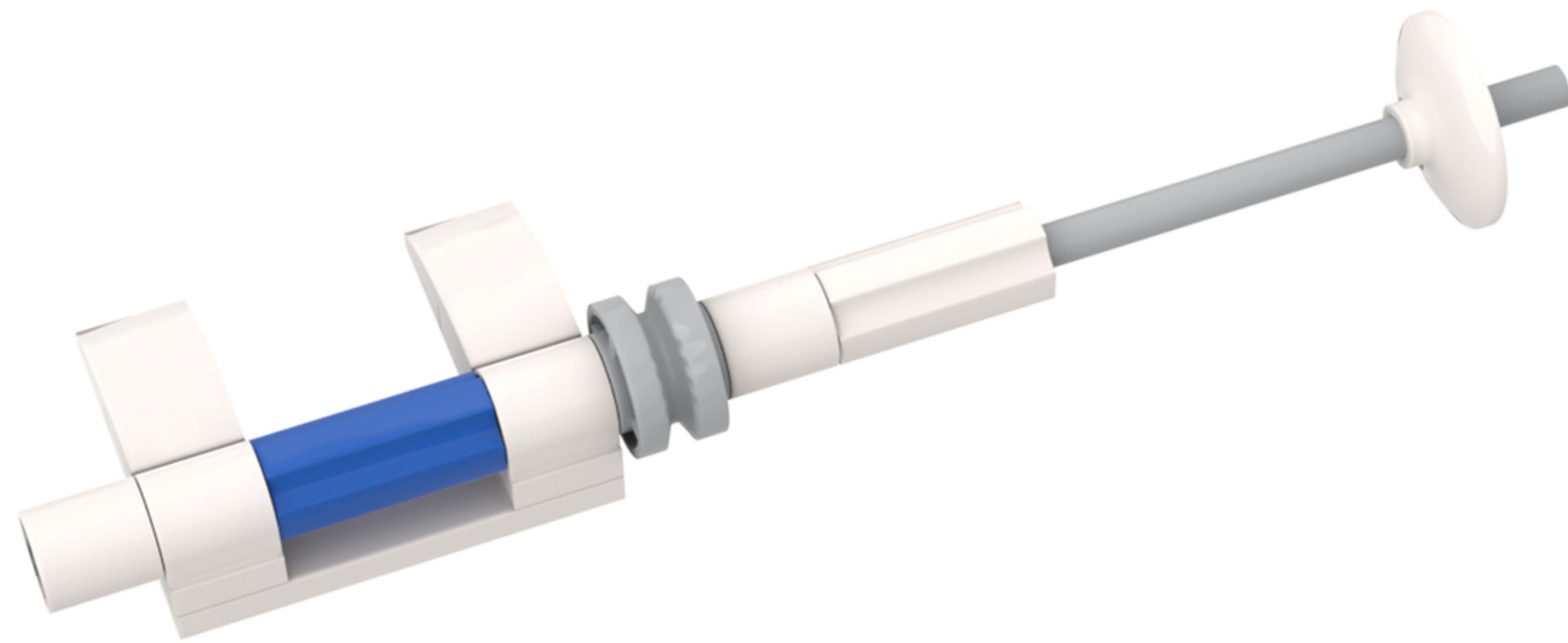
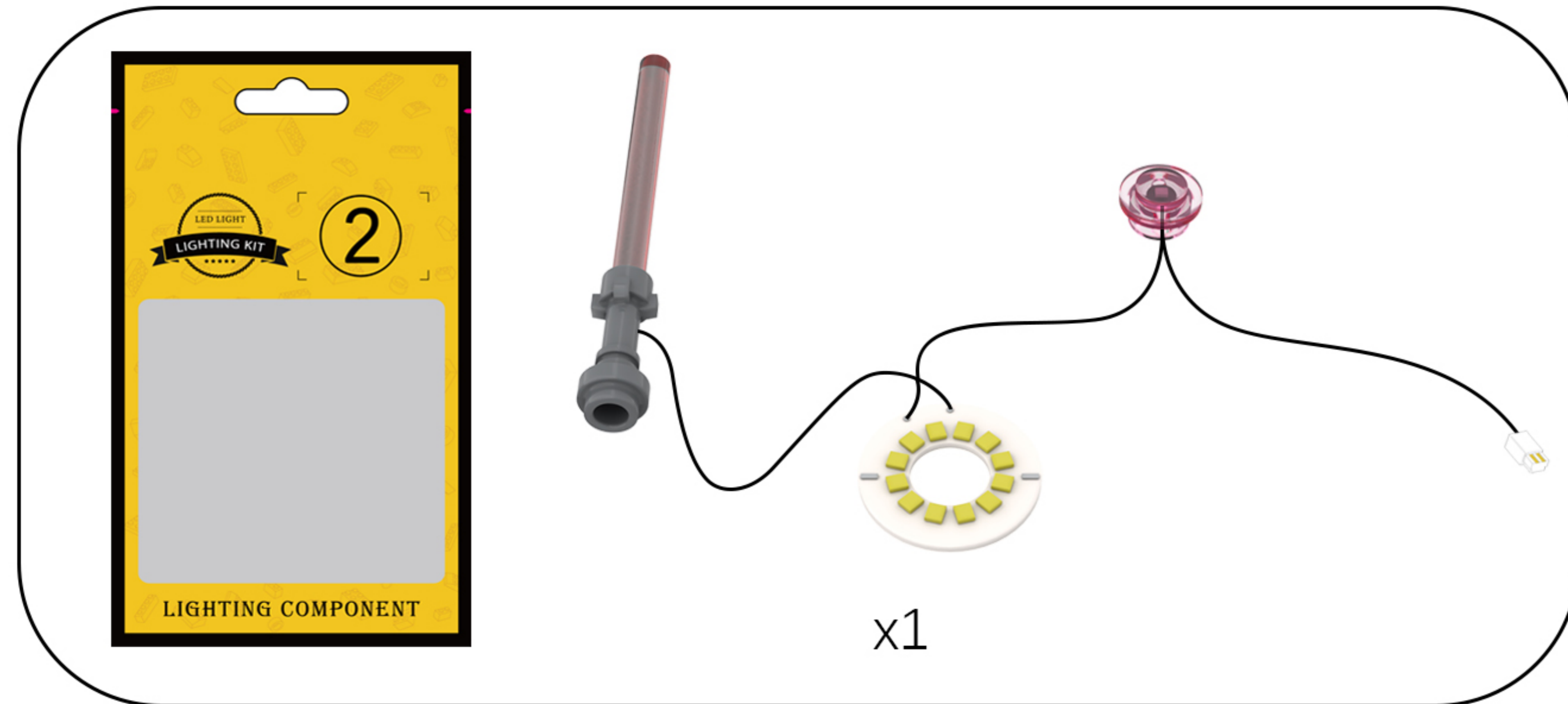

46

EN: Attach the lights from the string to the building blocks.

DE: Befestigen Sie die Lichter der Lichterkette an den Bausteinen.

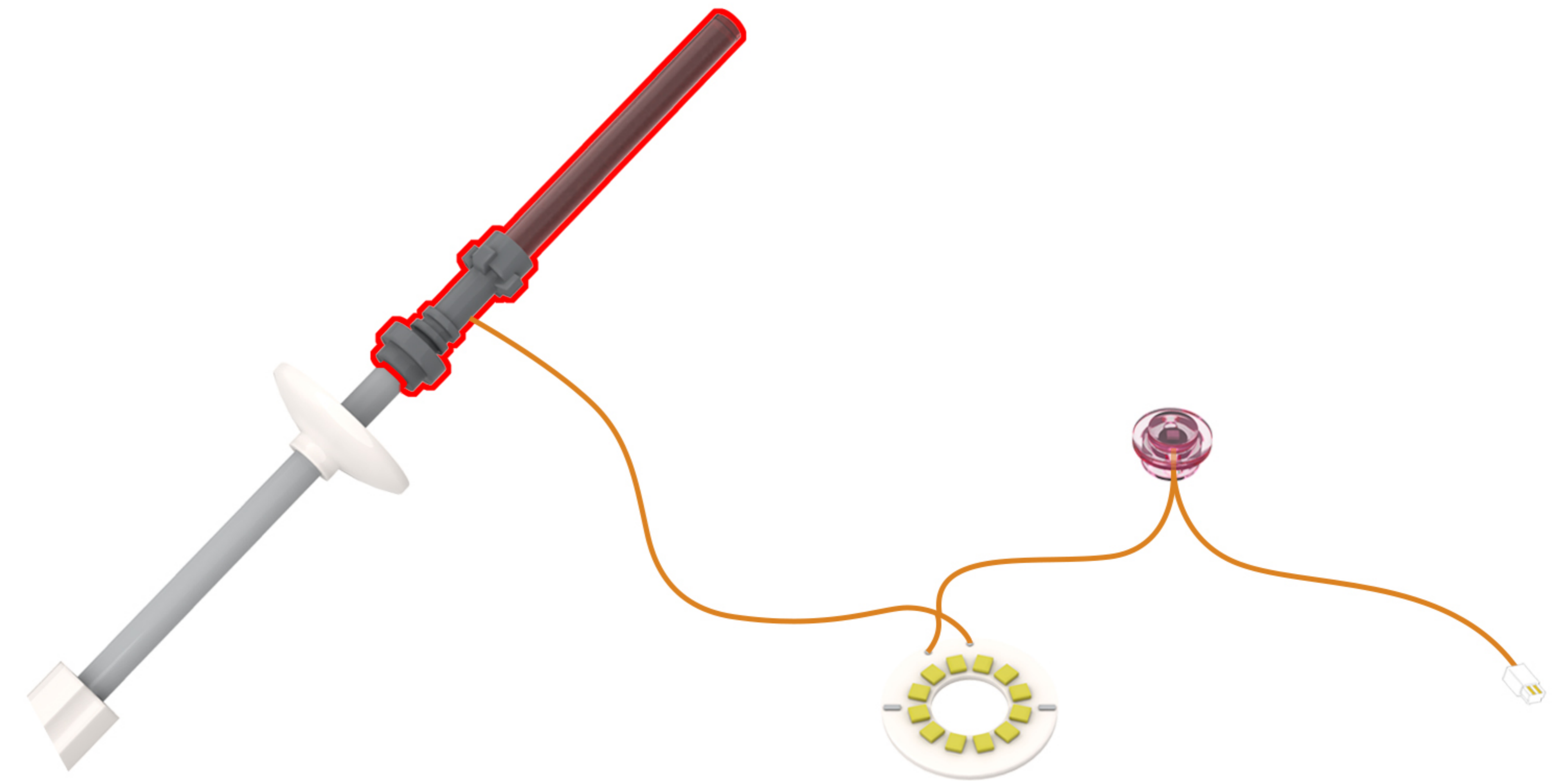

47

EN: Arrange the lighting lines according to the diagram.

DE: Ordnen Sie die Beleuchtungslinien gemäß der Abbildung an.

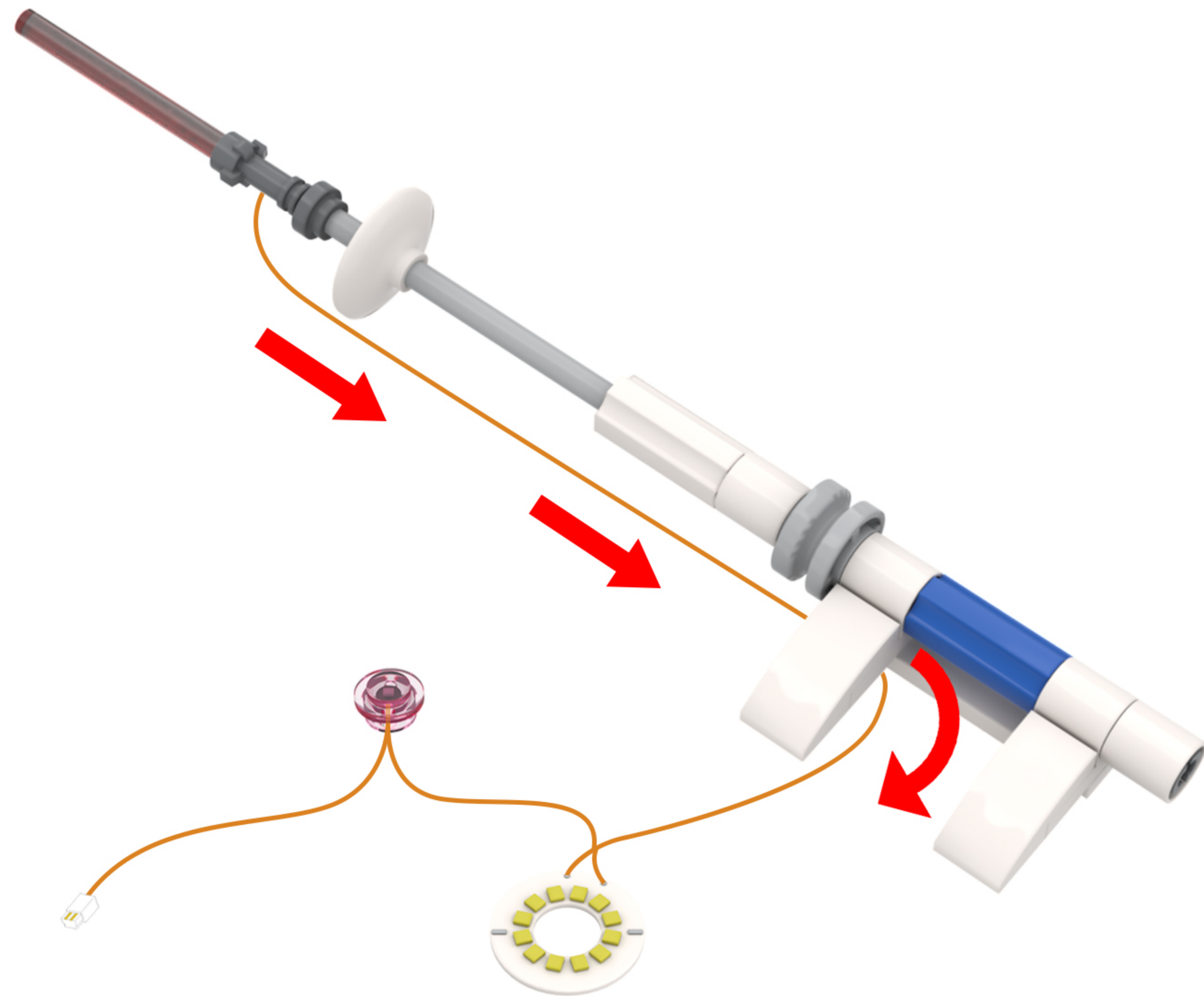

48

EN: Take out the disassembled building blocks, reassemble them, and secure the light cord.

DE: Nehmen Sie die zerlegten Bausteine heraus, setzen Sie sie wieder zusammen und befestigen Sie das Lichtkabel.

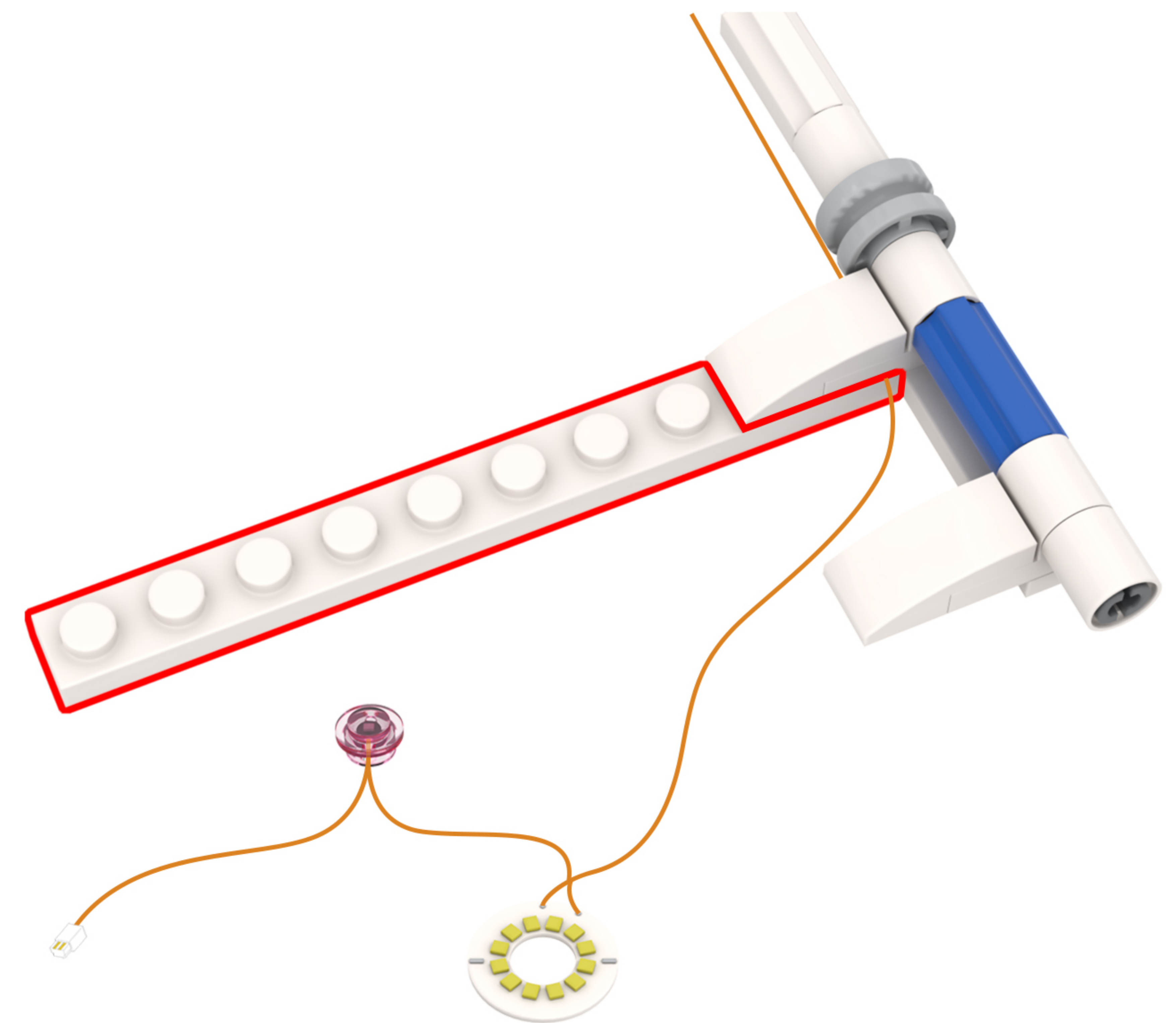
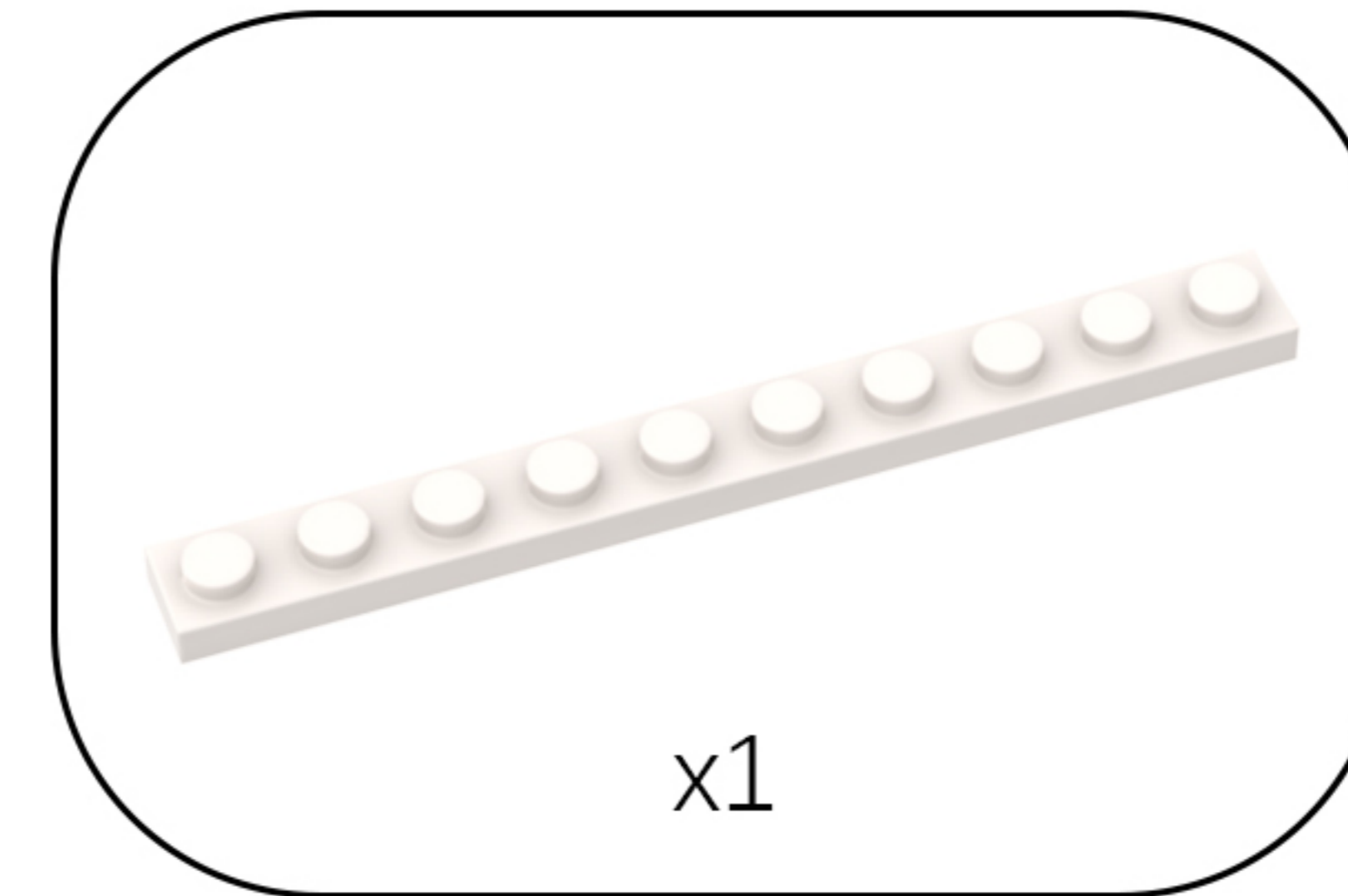

49

EN: Take out the disassembled building blocks and reassemble them.

DE: Nehmen Sie die zerlegten Bausteine heraus und setzen Sie sie wieder zusammen.

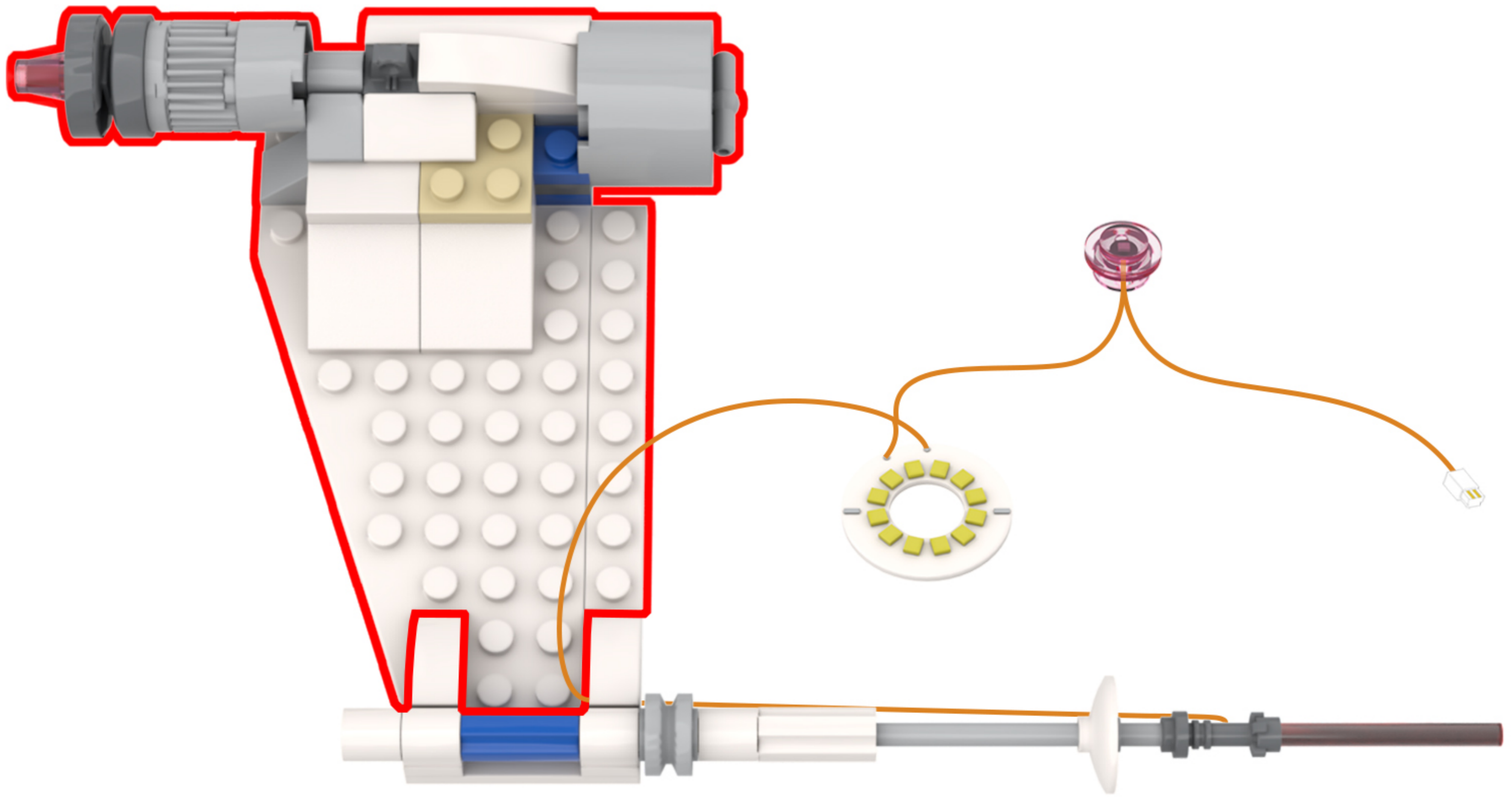
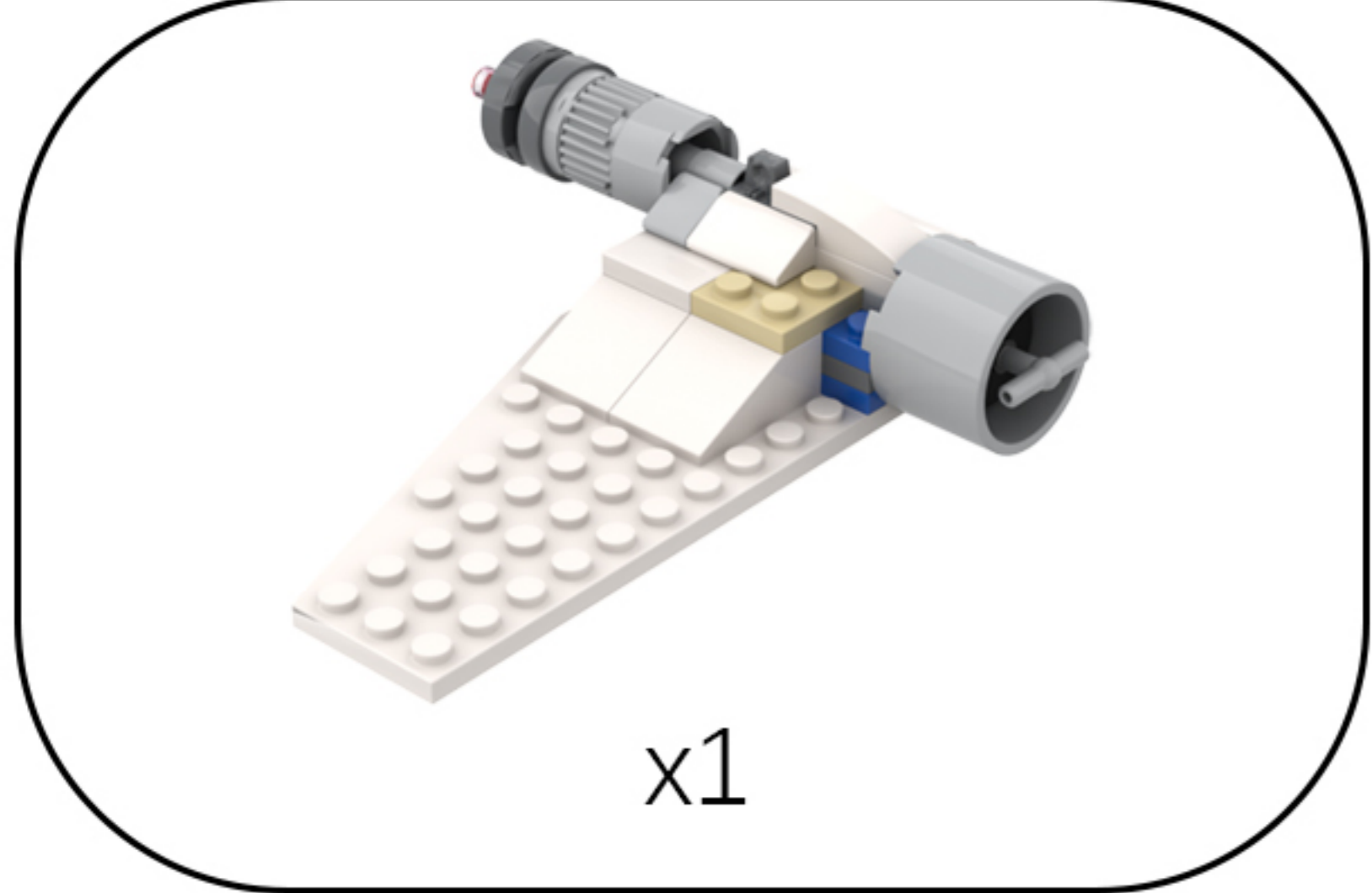

50

EN: Find the wire in the string of lights.

DE: Finde den Draht in der Lichterkette.

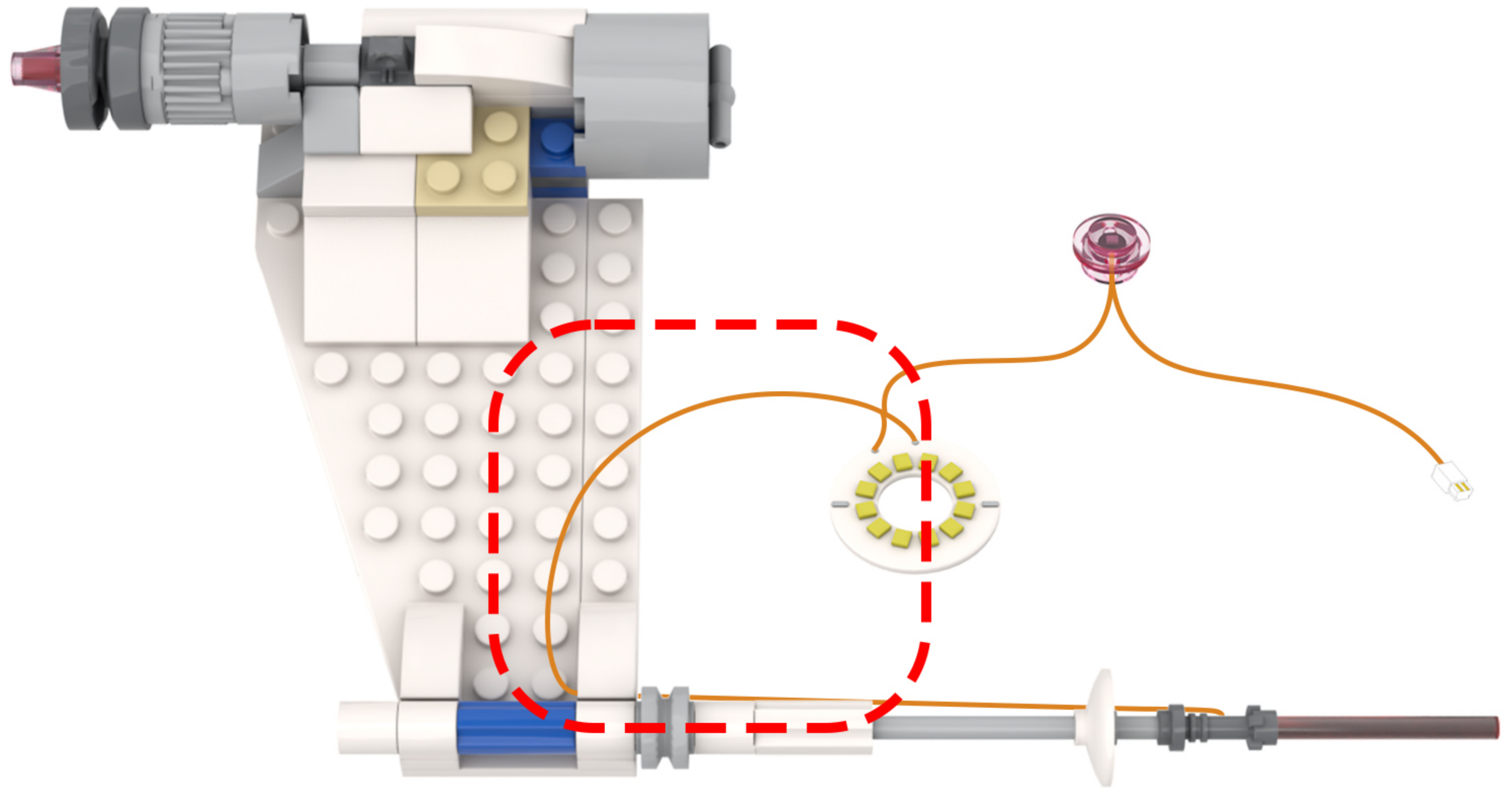

51

EN: Route the light cable around the protrusions on the building blocks and toward the other side.

DE: Führen Sie das Lichtkabel um die Vorsprünge an den Bausteinen herum und zur anderen Seite.

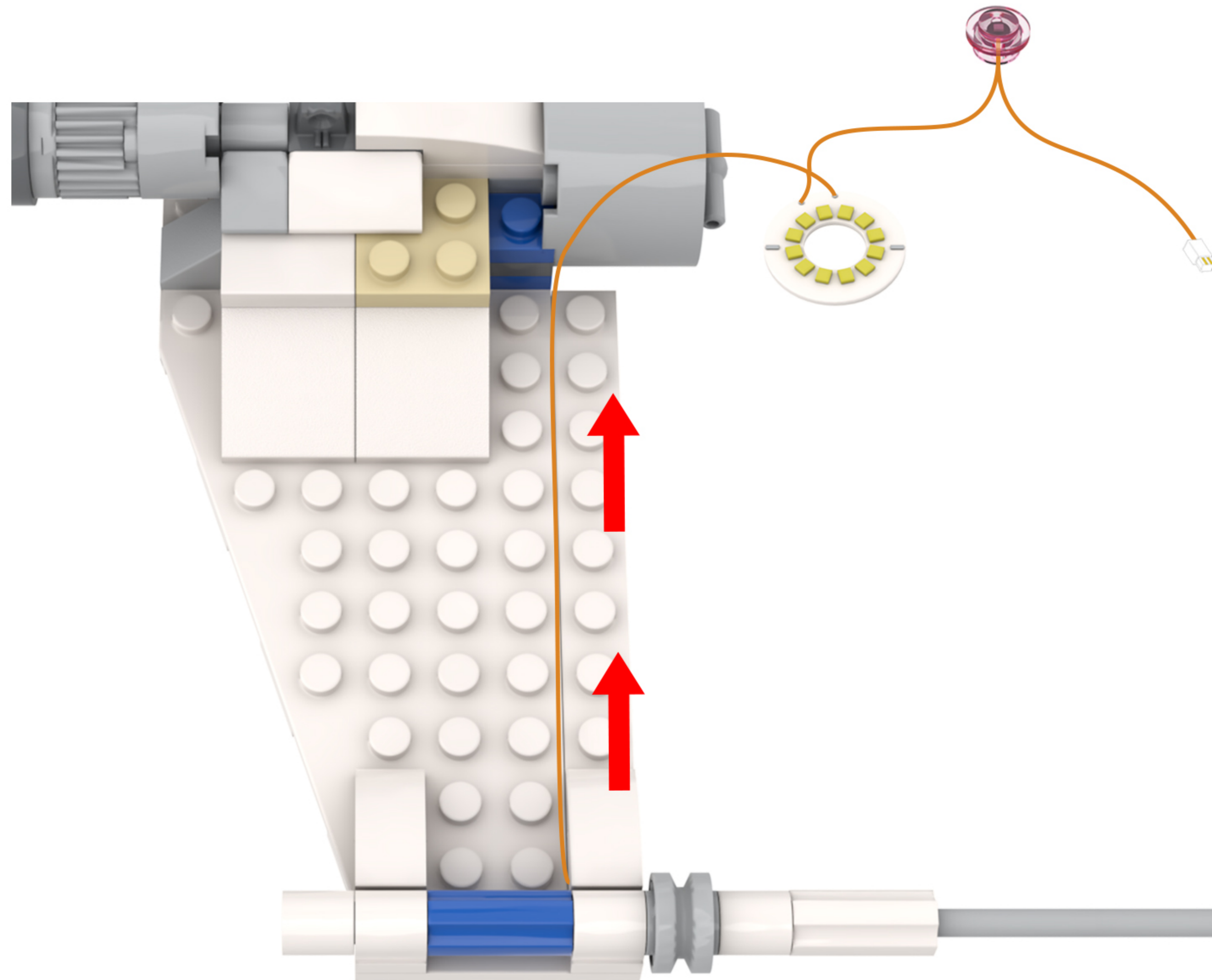

52

EN: Take out the disassembled building blocks, reassemble them, and secure the light cord.

DE: Nehmen Sie die zerlegten Bausteine heraus, setzen Sie sie wieder zusammen und befestigen Sie das Lichtkabel.

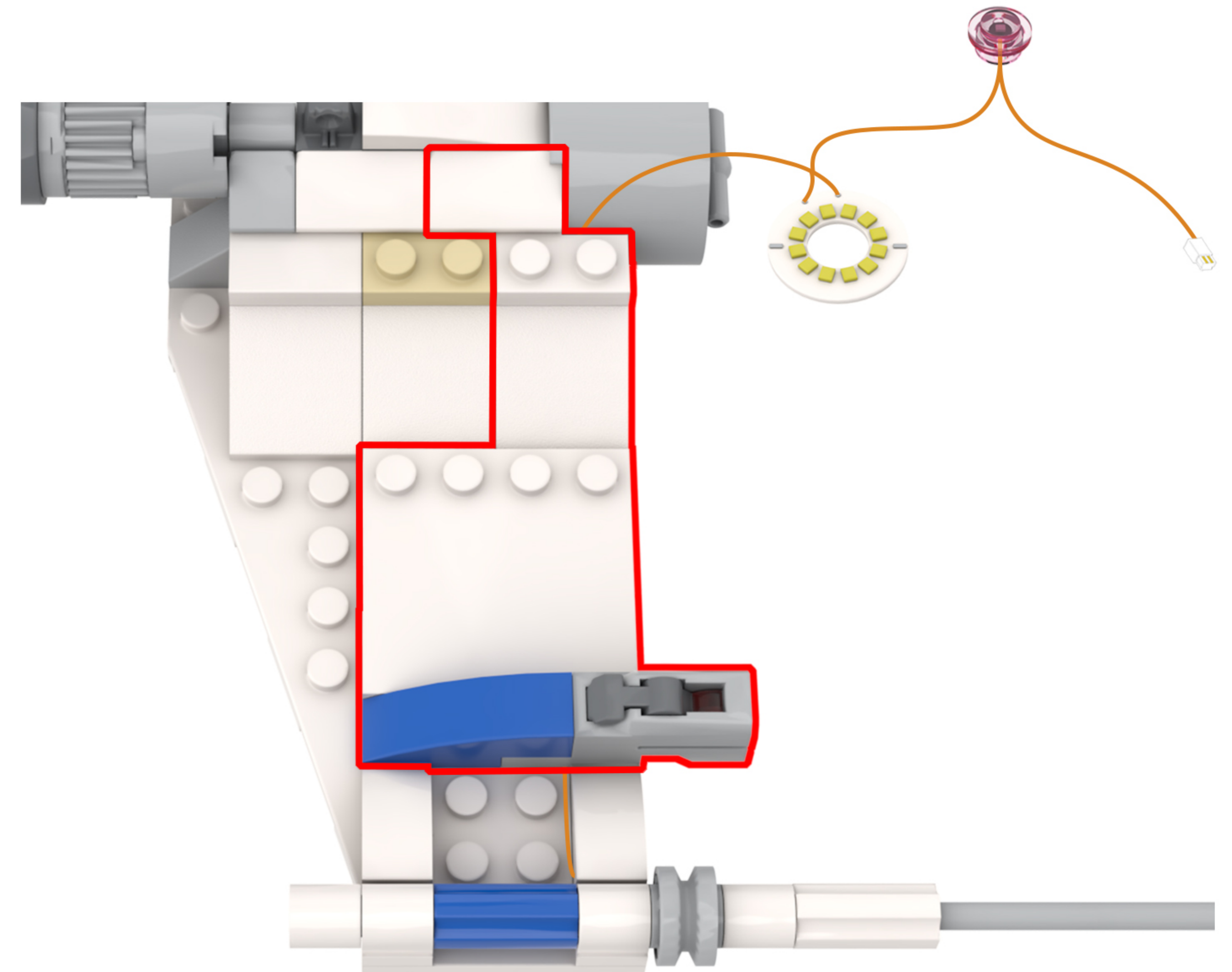
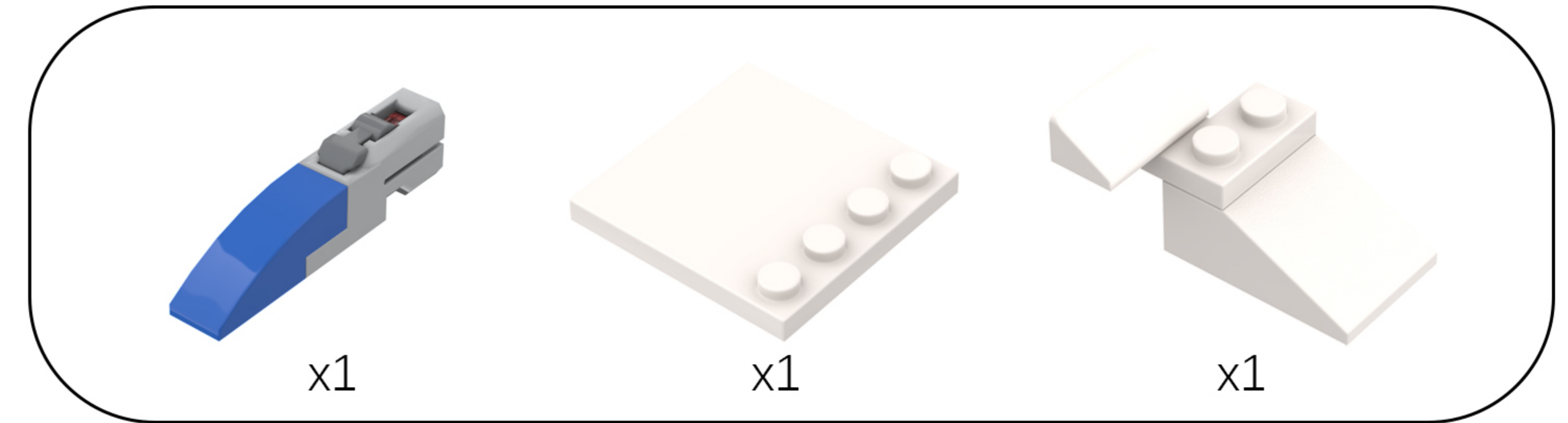

53

EN: Adjust your perspective.

DE: Ändern Sie Ihre Perspektive.

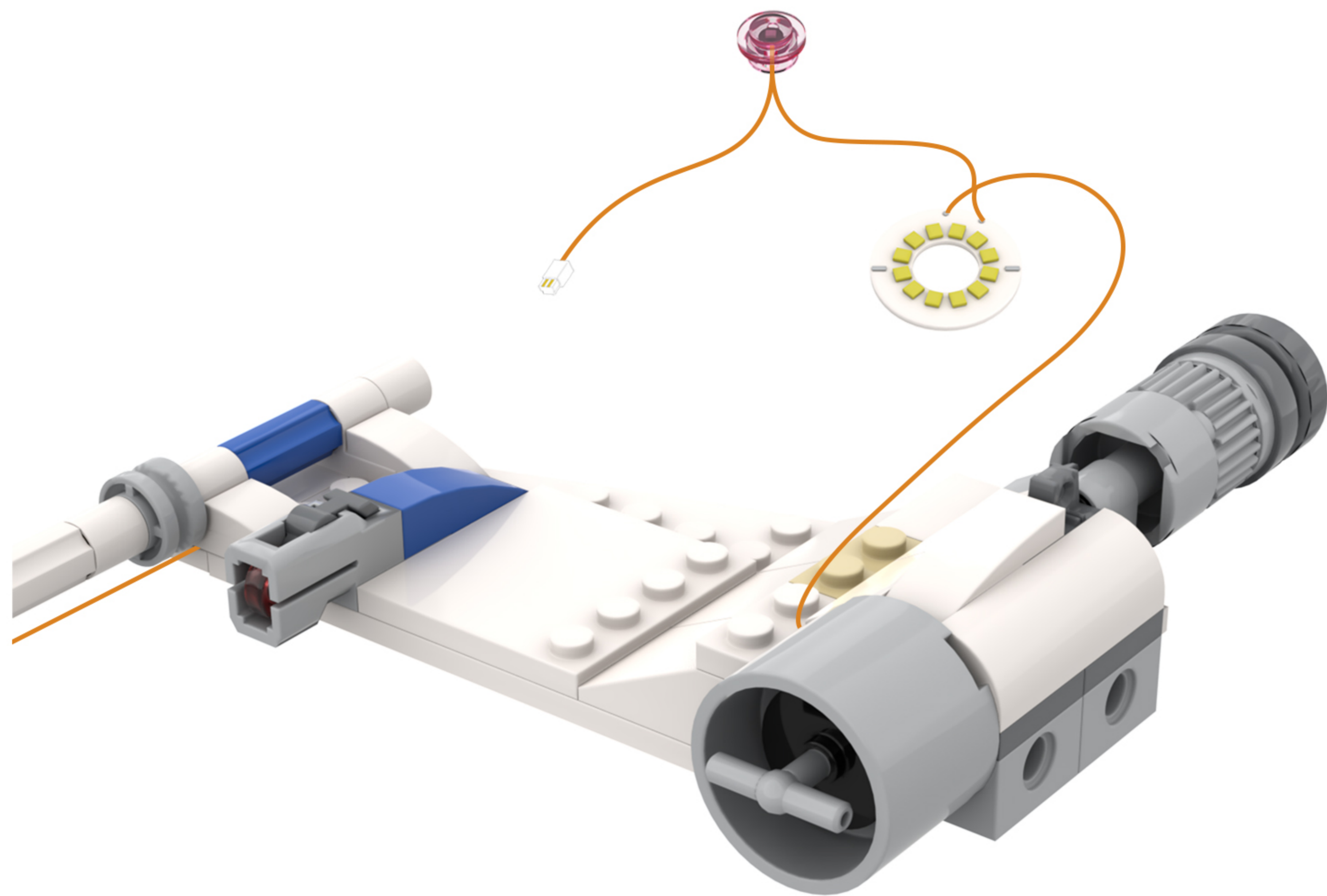

54

EN: Split as shown in the figure.

DE: Wie in der Abbildung gezeigt, teilen Sie es auf.

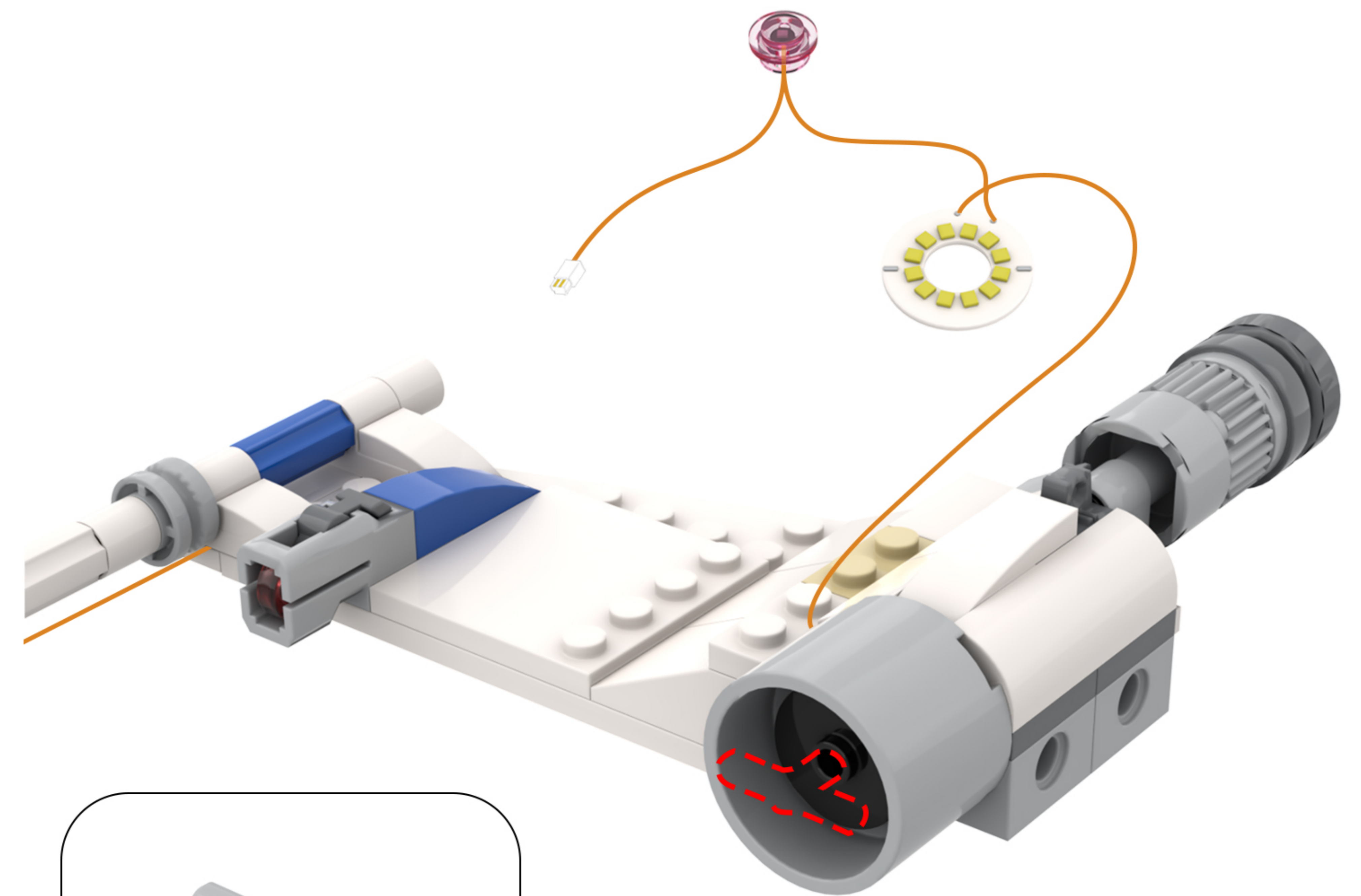

55

EN: Rotate the model to the side and locate the block shown in the figure.

DE: Drehen Sie das Modell zur Seite und suchen Sie den in der Abbildung gezeigten Block.

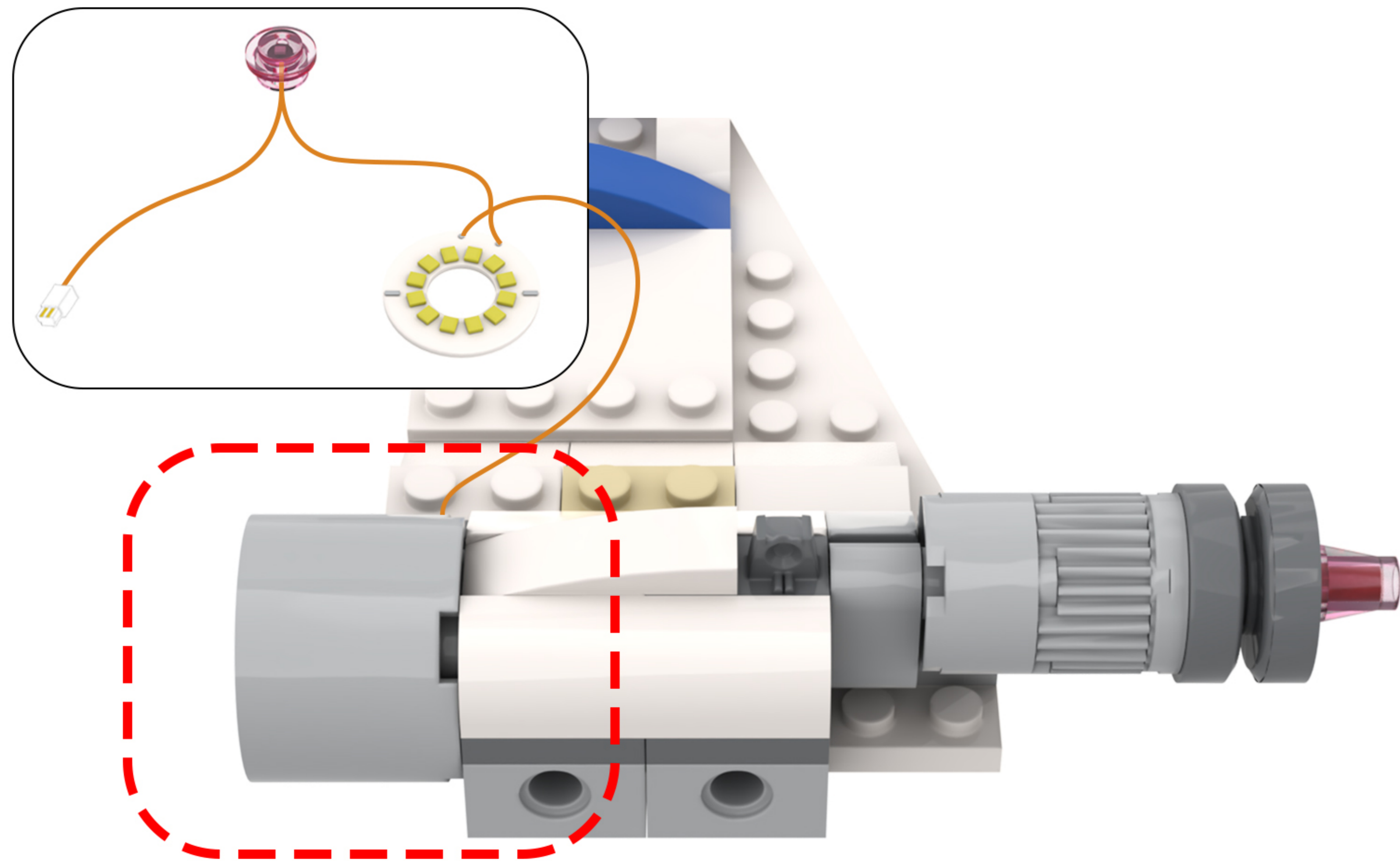

56

EN: Pull the building block out slightly.

DE: Zieh den Baustein ein wenig heraus.

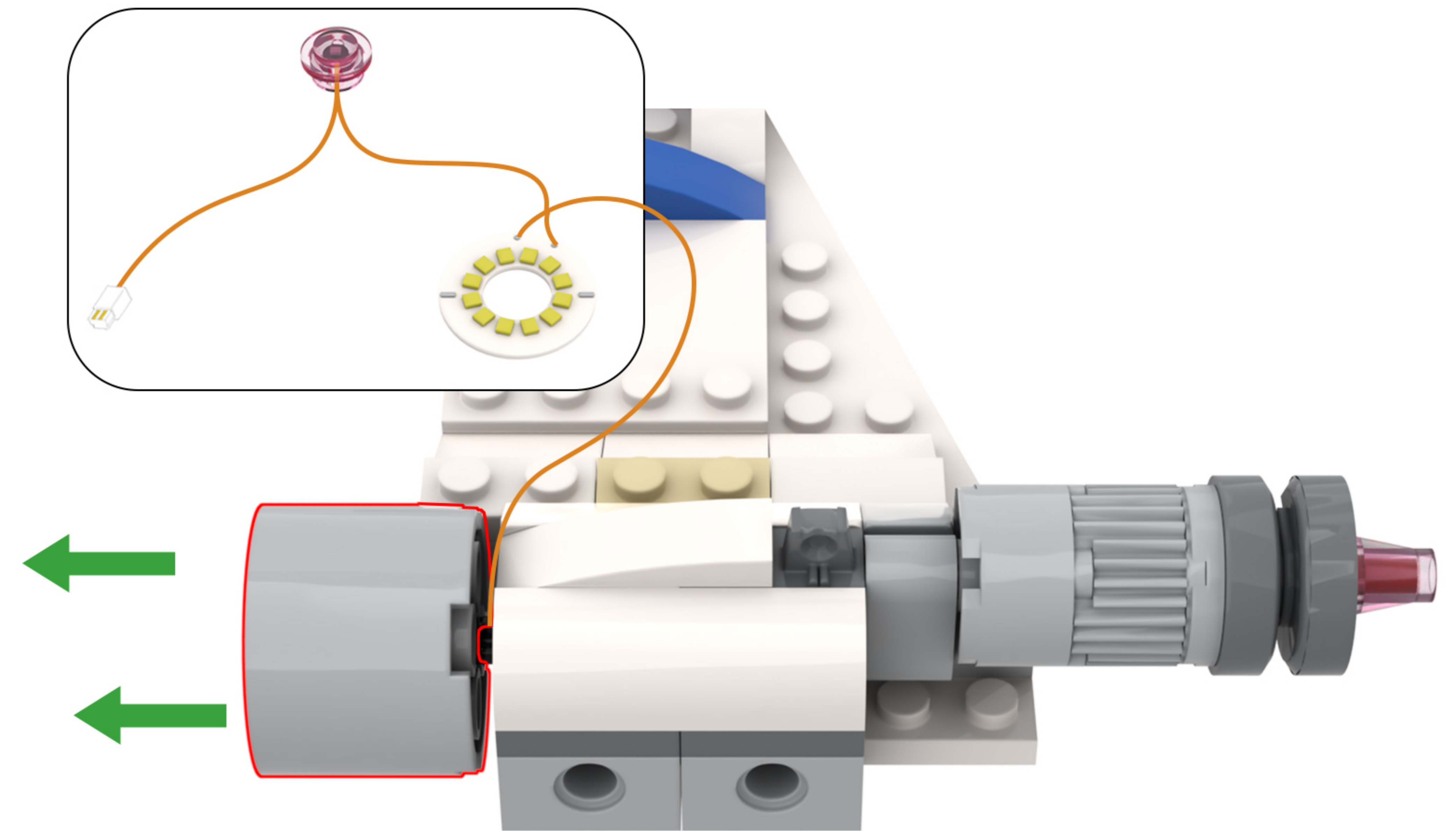

57

EN: Find the wire in the string of lights.

DE: Finde den Draht in der Lichterkette.

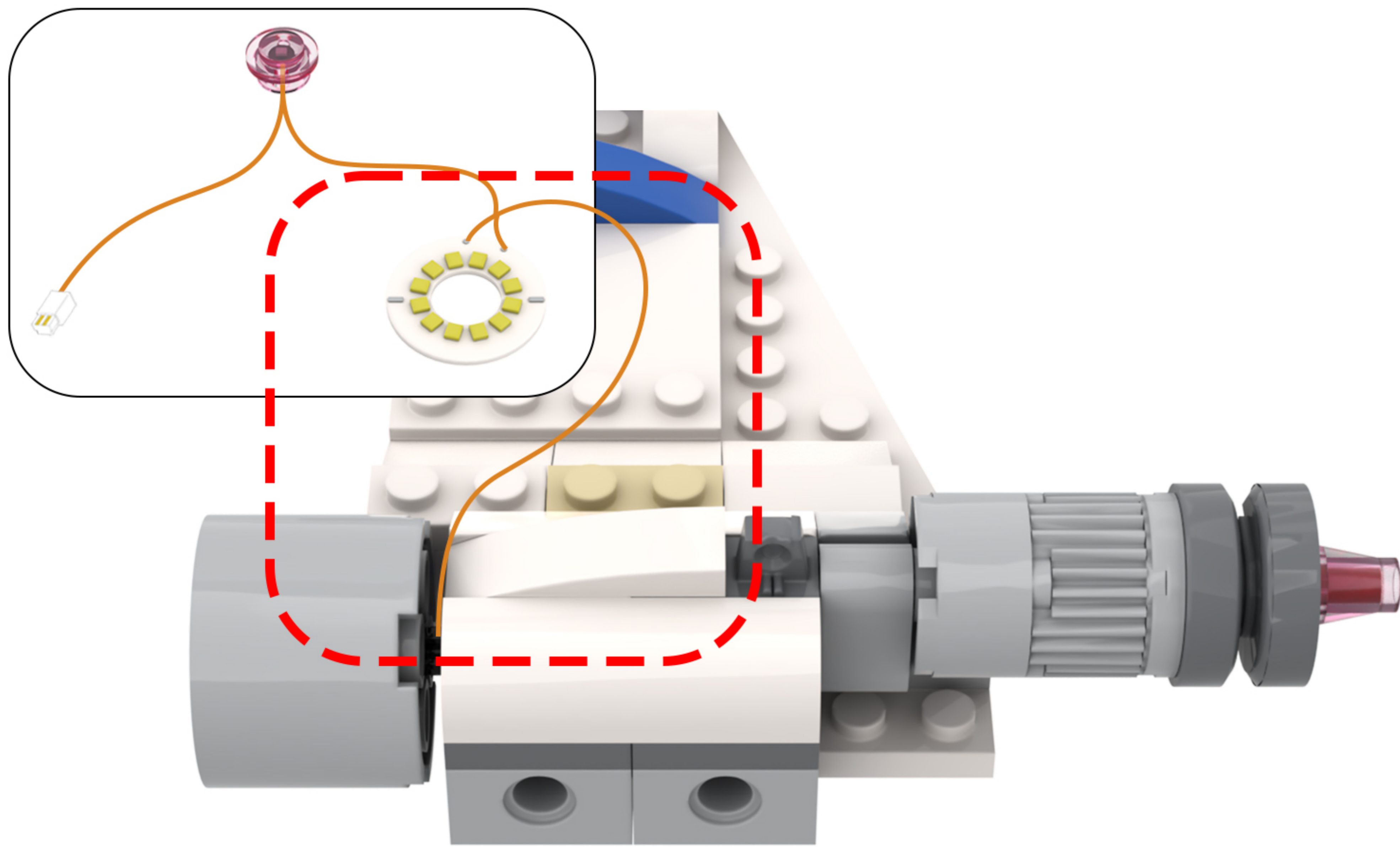

58

EN: Wrap the lamp cord around the crossbar once.

DE: Wickeln Sie das Lampenkabel einmal um die Querstange.

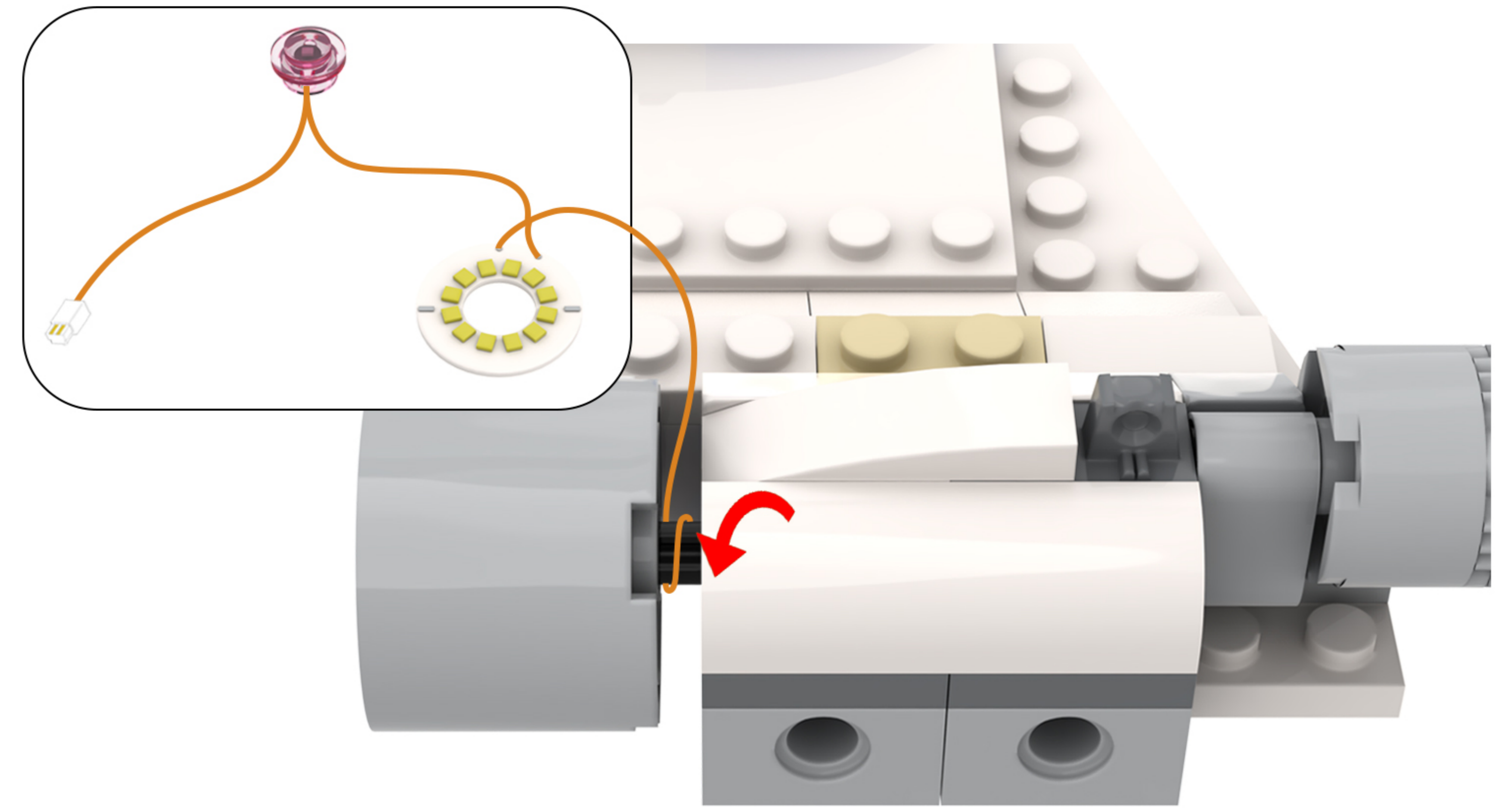

59

EN: Place the lights from the string on the building blocks.

DE: Befestige die Lichter der Lichterkette an den Bausteinen.

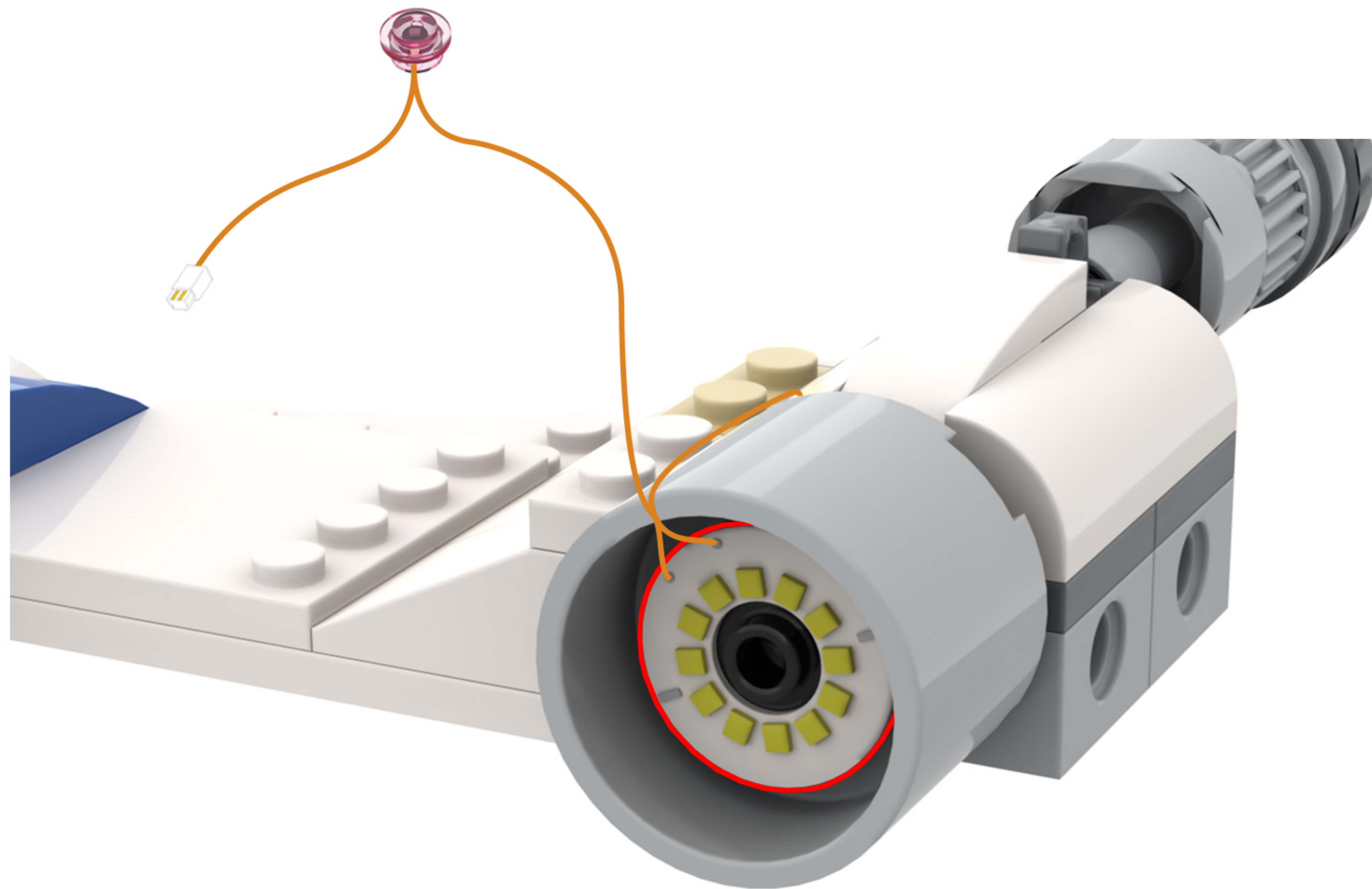

60

EN: Take out the disassembled building blocks and reassemble them.

DE: Nehmen Sie die zerlegten Bausteine heraus und setzen Sie sie wieder zusammen.

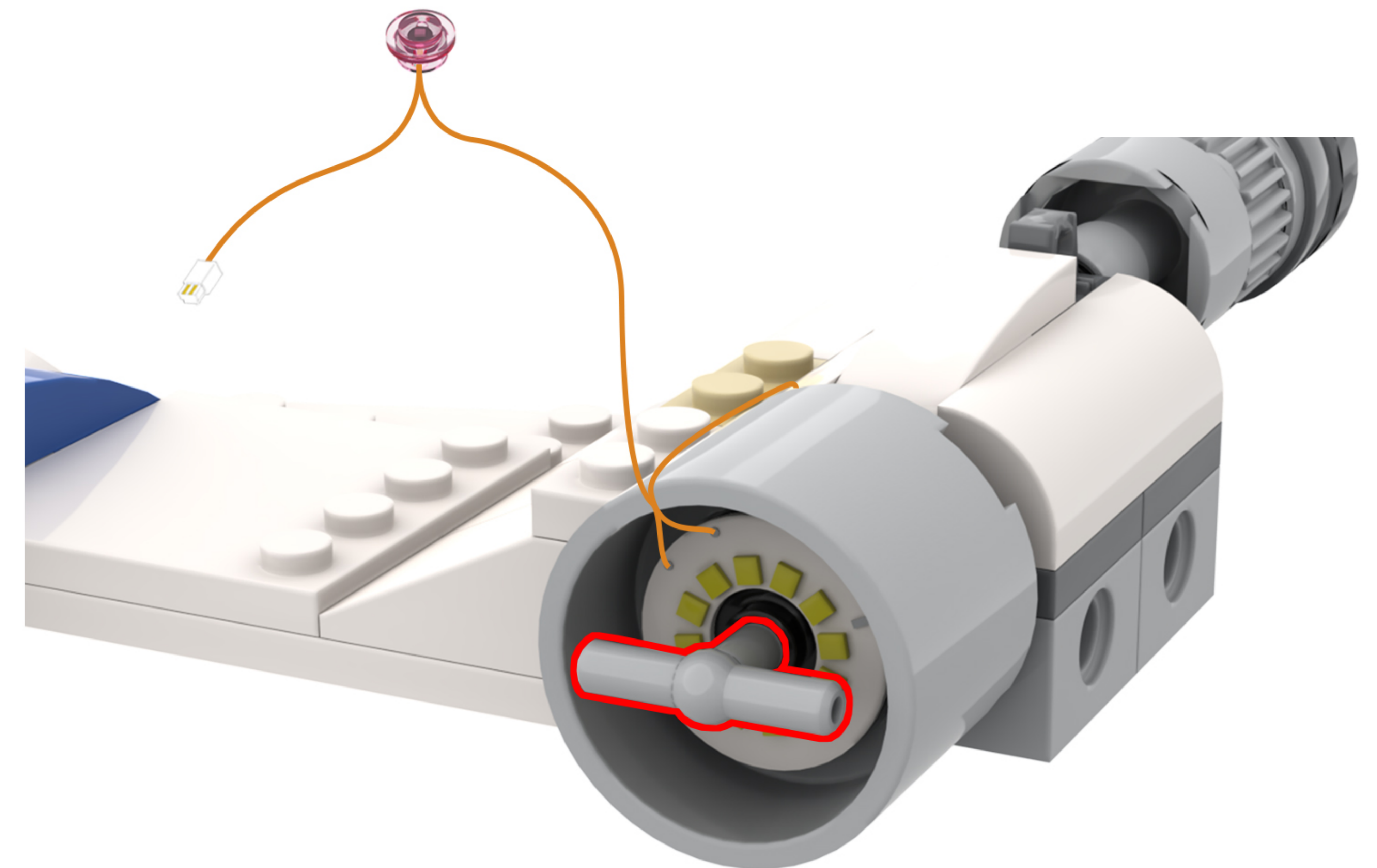
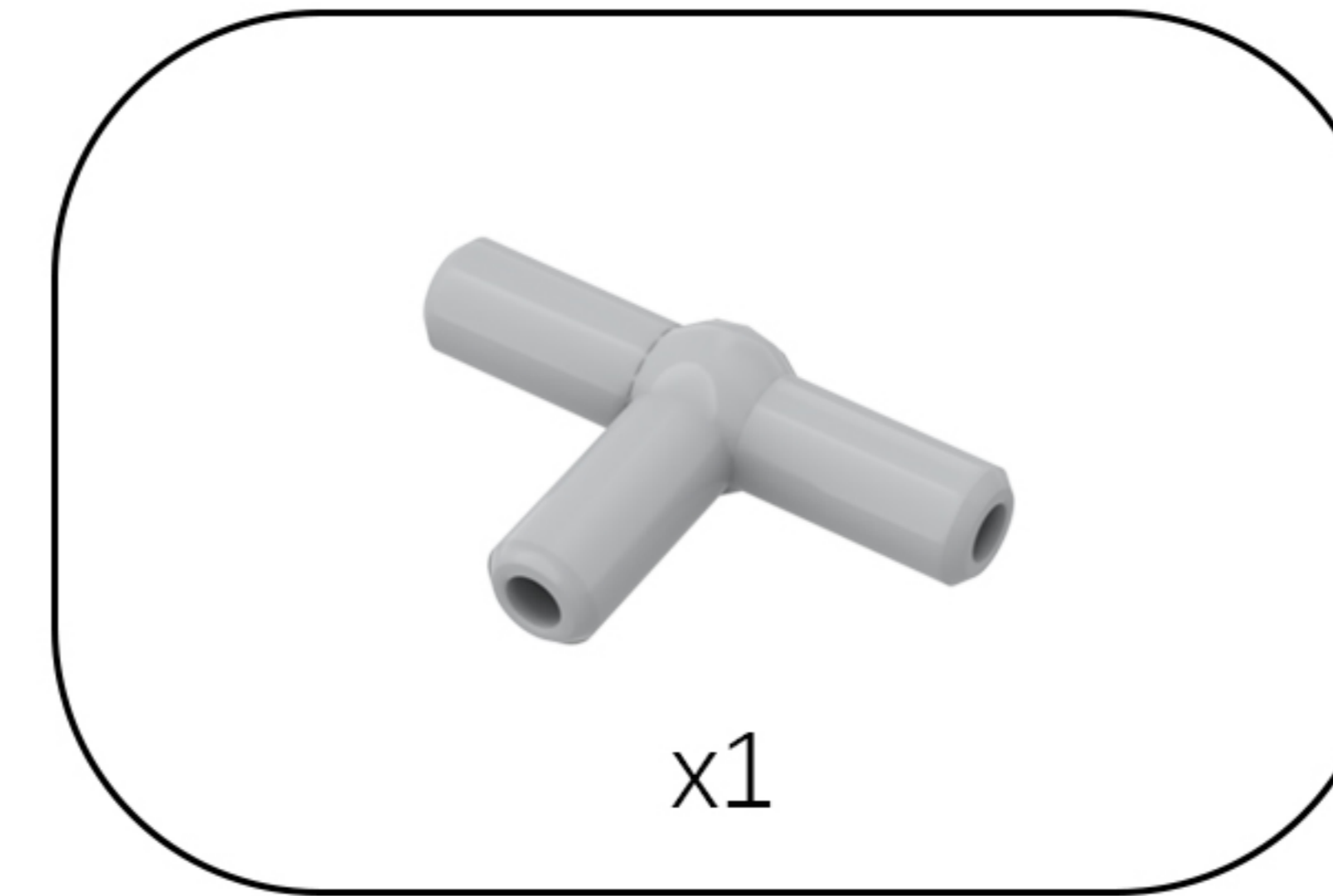

61

EN: Locate this light cord in the diagram.

DE: Suchen Sie dieses Lichtkabel in der Abbildung.

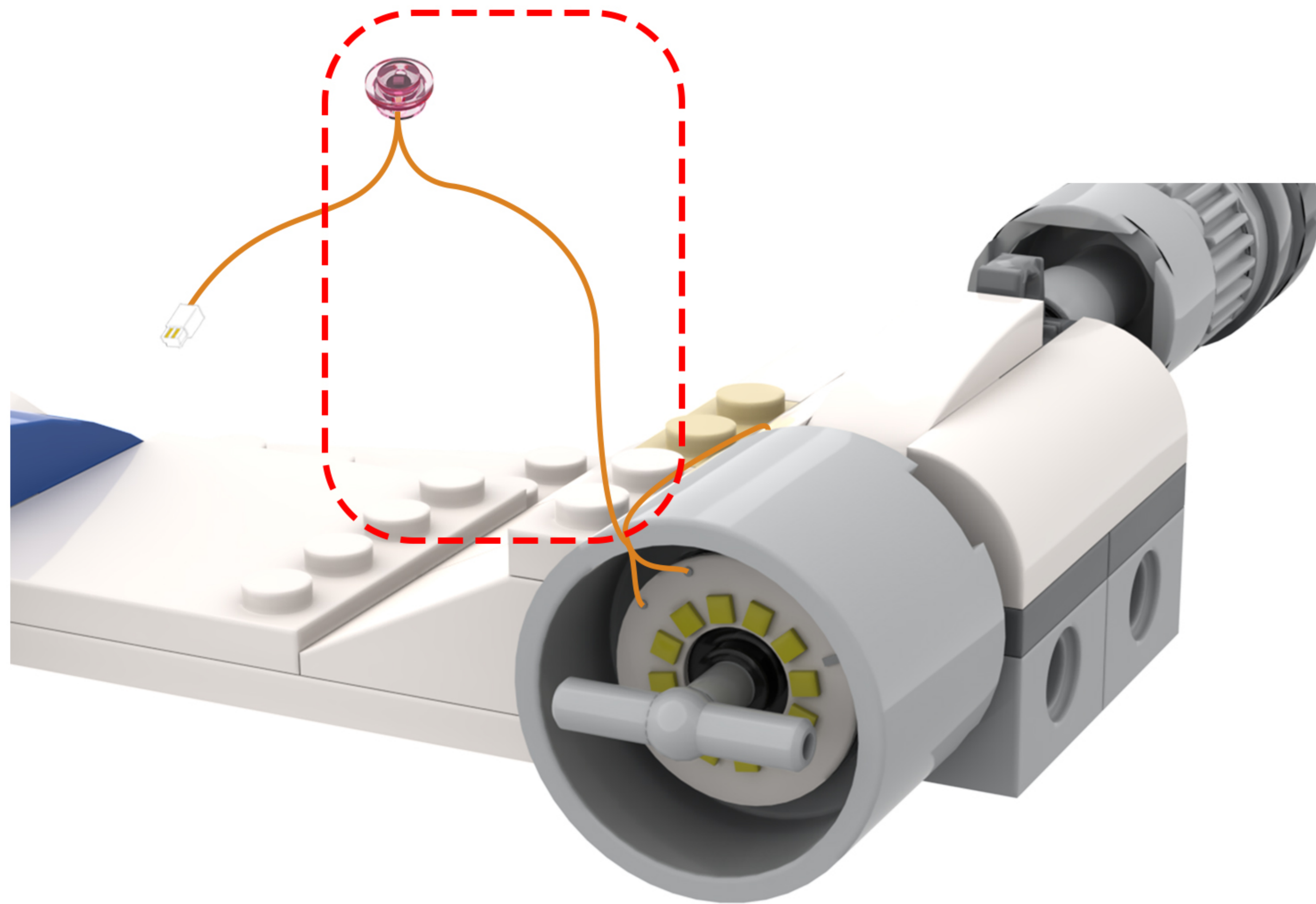

62

EN: Return the building blocks to their original positions so that they press down on the light cord.

DE: Bringen Sie die Bausteine wieder in ihre ursprüngliche Position, sodass sie auf das Lichtkabel drücken.

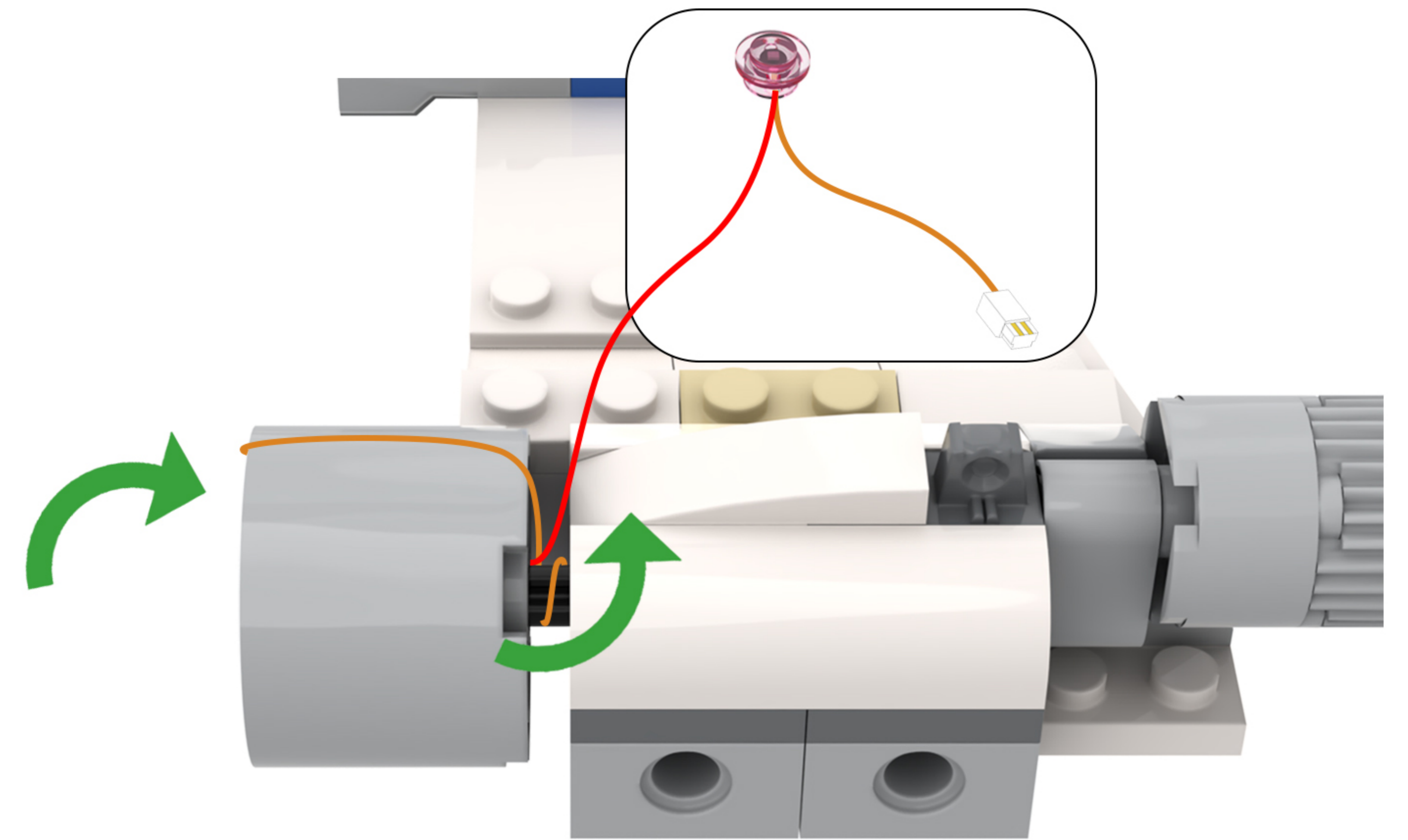

63

EN: Return the building blocks to their original positions so that they press down on the light cord.

DE: Bringen Sie die Bausteine wieder in ihre ursprüngliche Position, sodass sie auf das Lichtkabel drücken.

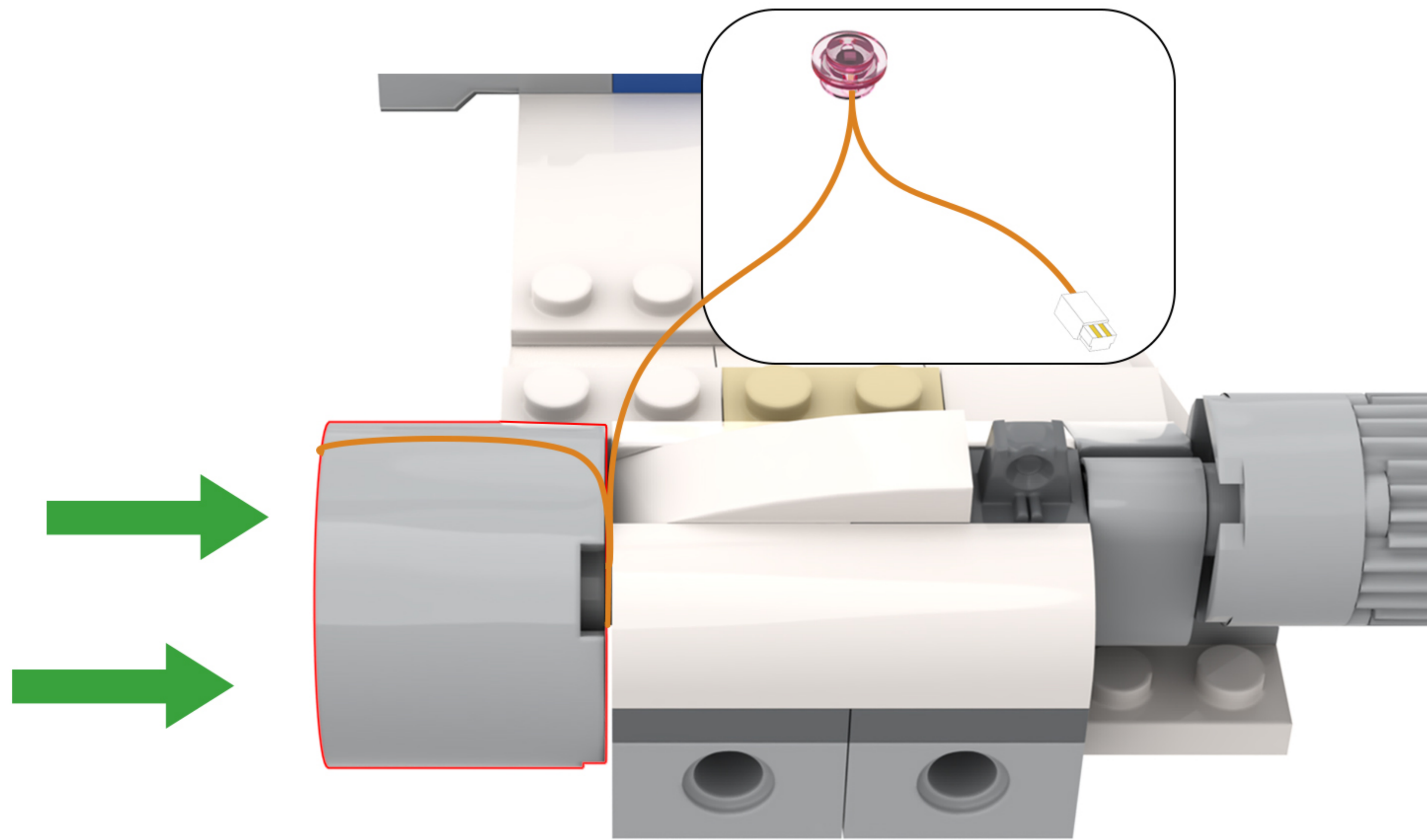

64

EN: Adjust your perspective.

DE: Ändern Sie Ihre Perspektive.

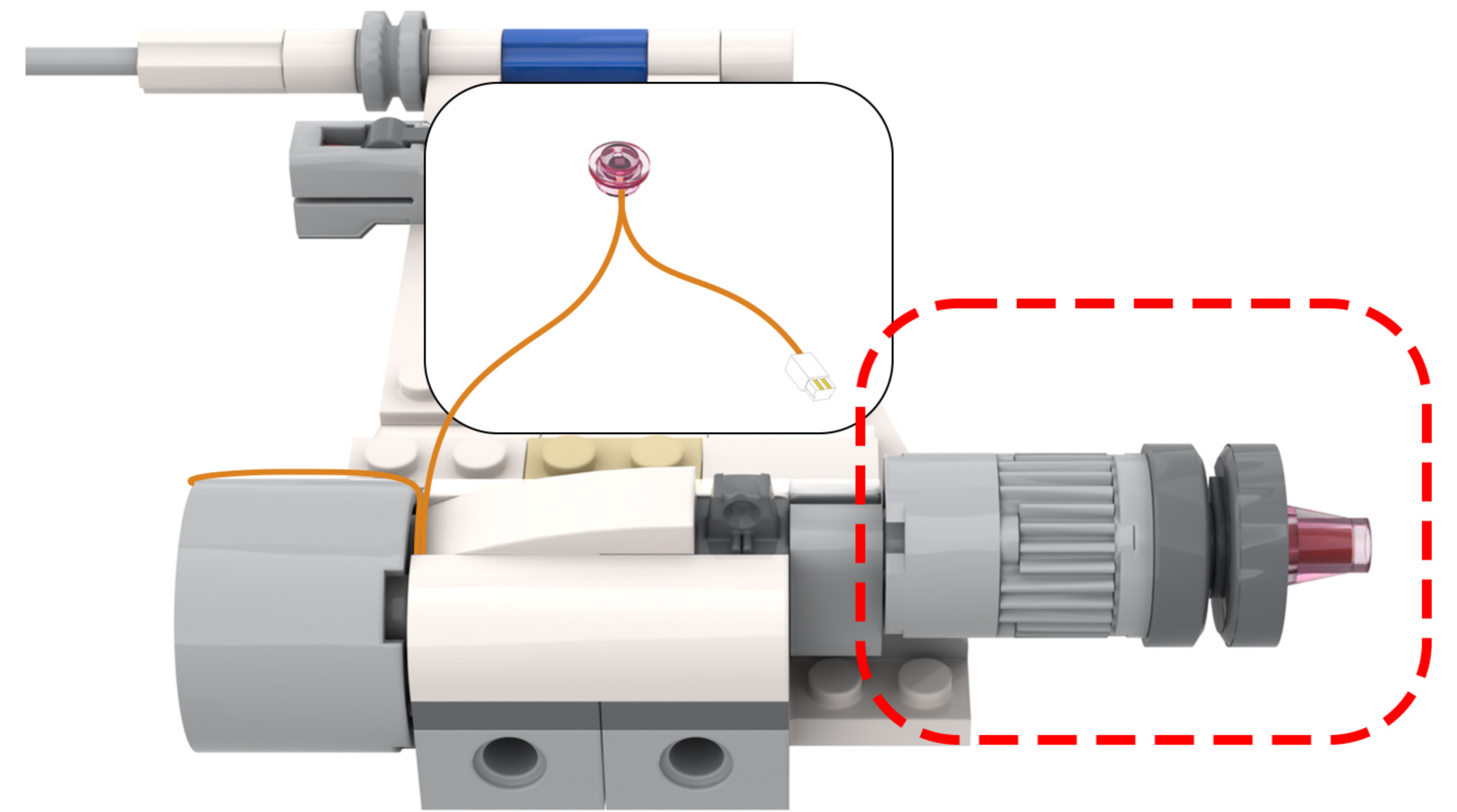

65

EN: Pull the building block out slightly.

DE: Zieh den Baustein ein wenig heraus.

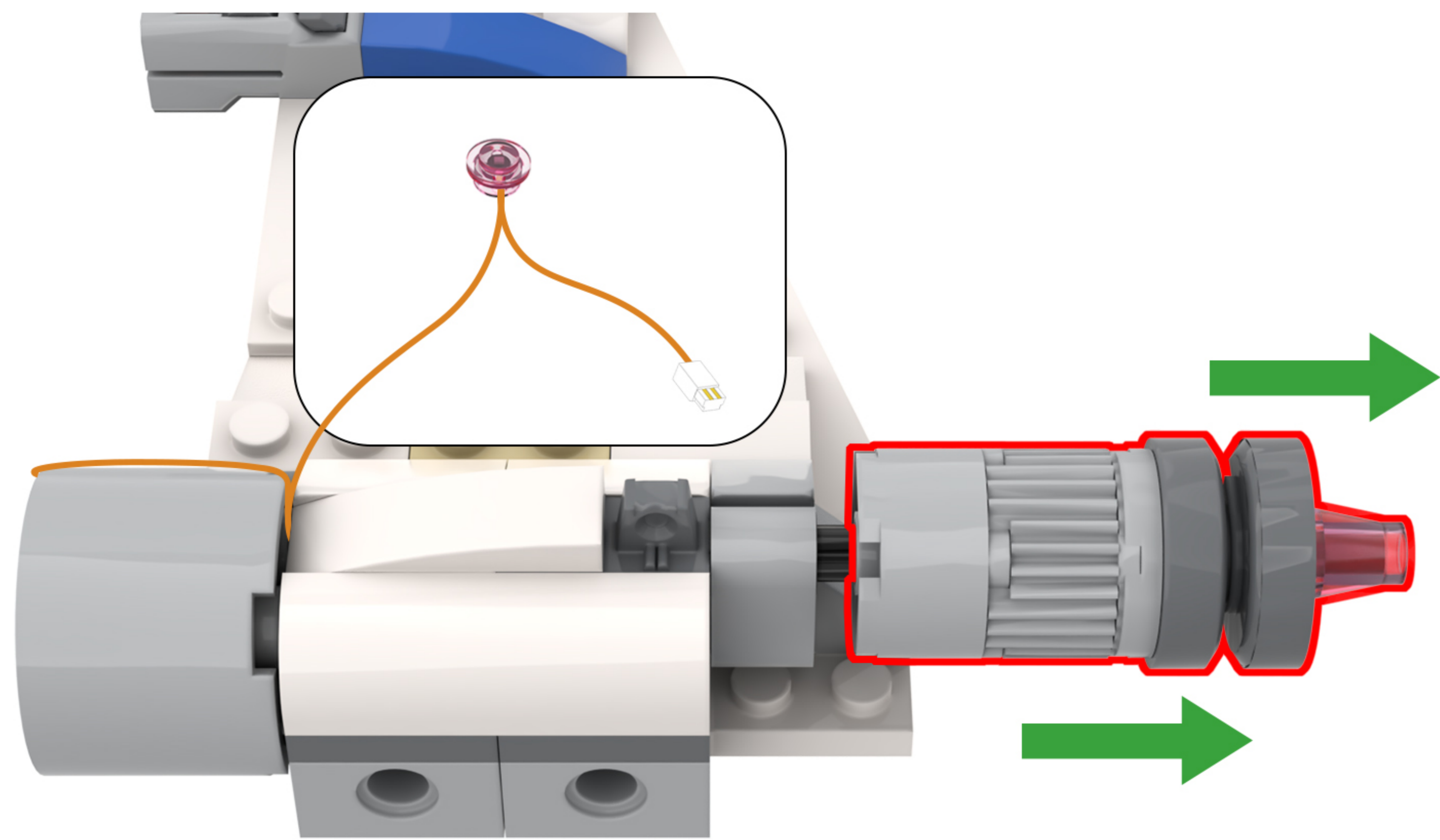

66

EN: Wrap the light cord around the building block once.

DE: Wickle das Lichterkabel einmal um den Baustein.

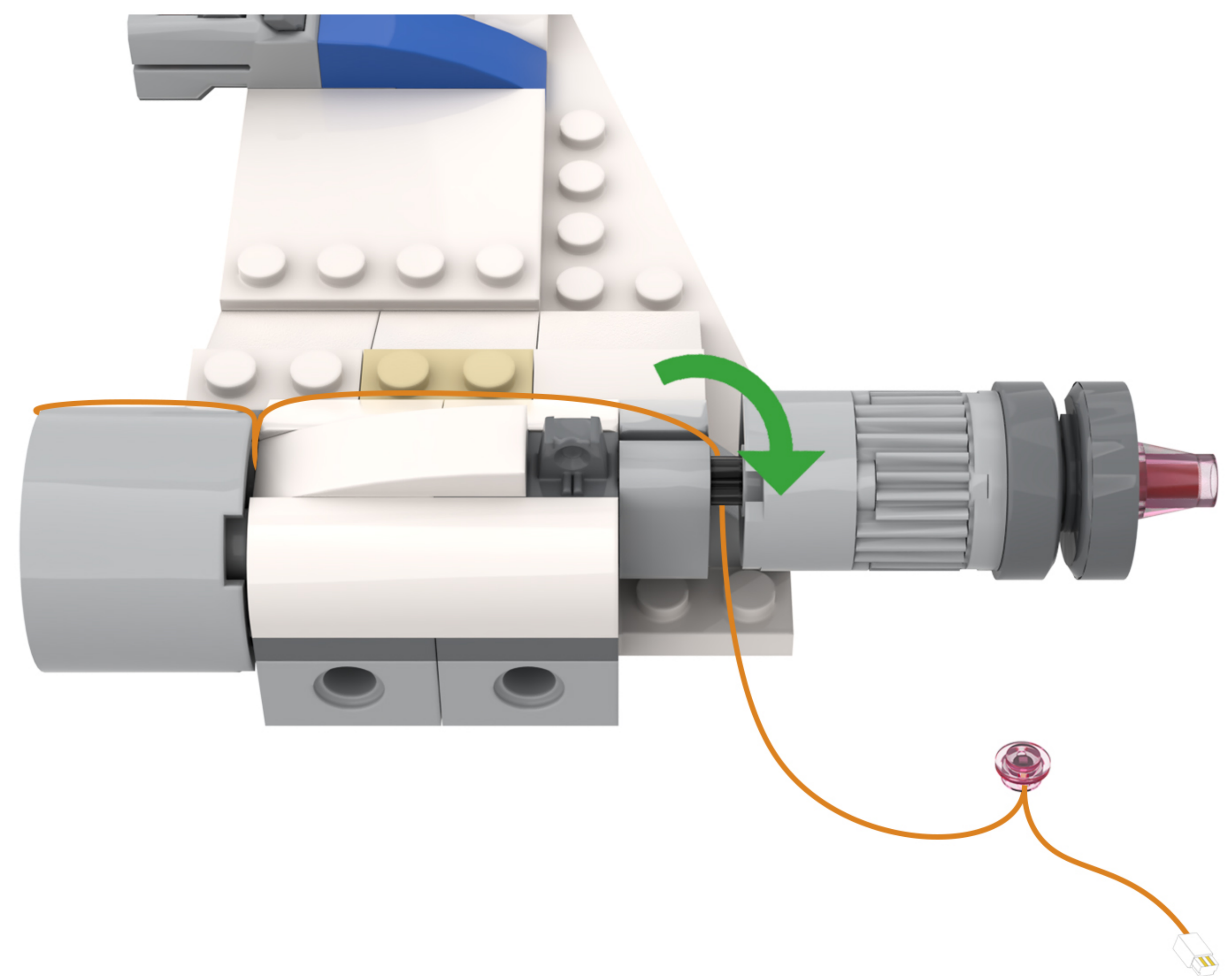

67

EN: Attach the lights from the string to the building blocks.

DE: Befestigen Sie die Lichter der Lichterkette an den Bausteinen.

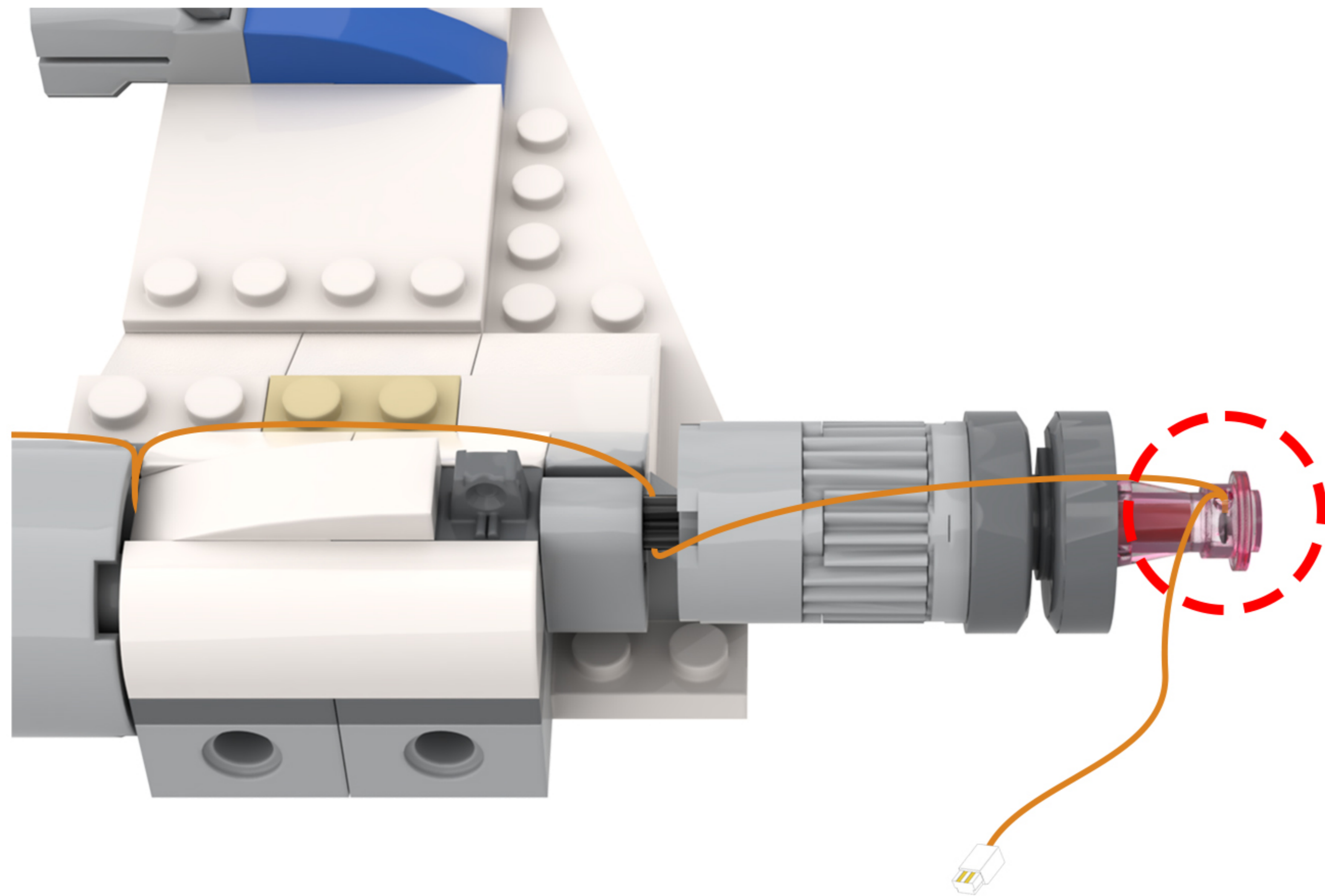

68

EN: Locate this light cord in the diagram.

DE: Suchen Sie dieses Lichtkabel in der Abbildung.

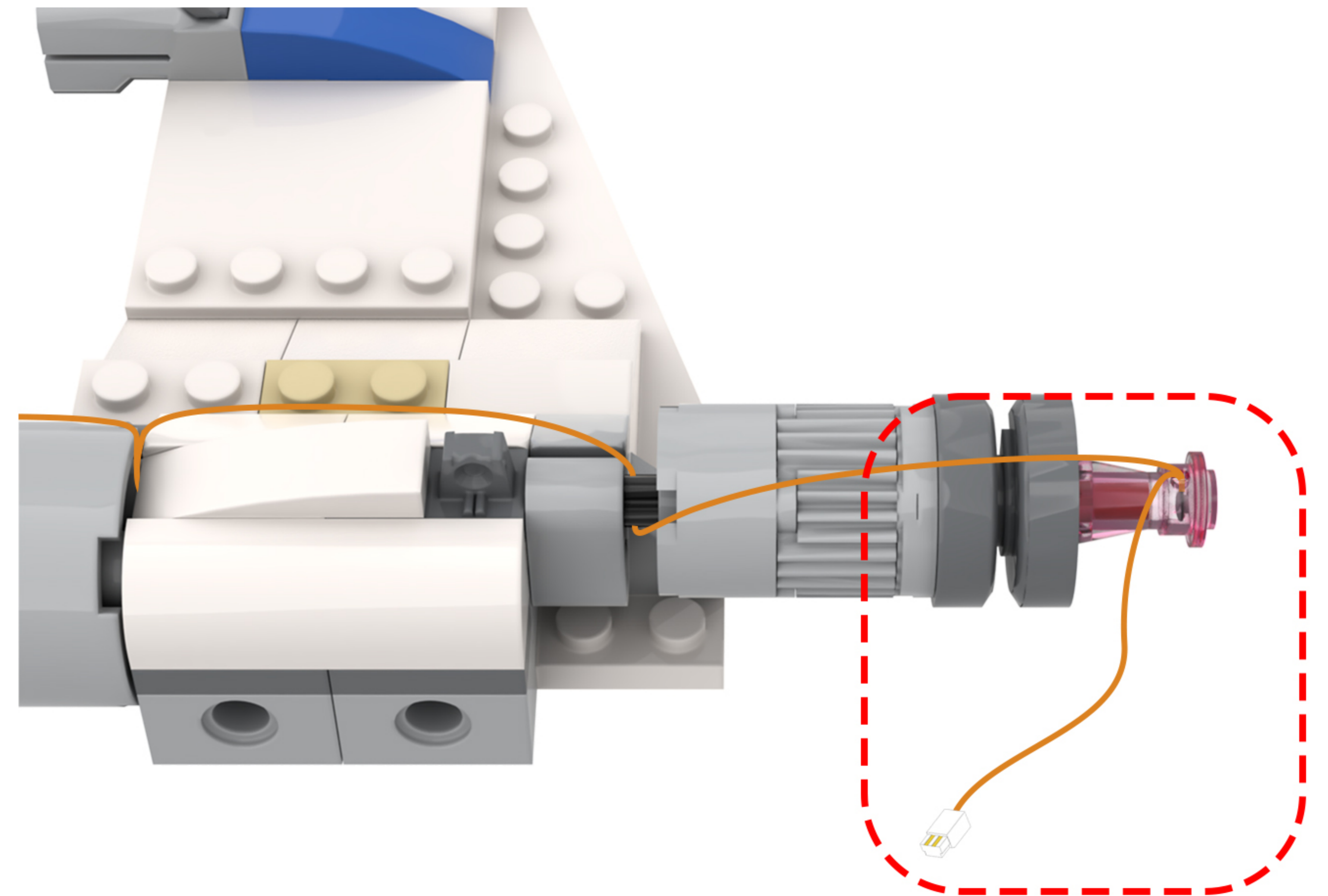

69

EN: Slide the light cord back into the gap in the building block.

DE: Schieben Sie das Lichtkabel wieder in den Spalt im Baustein.

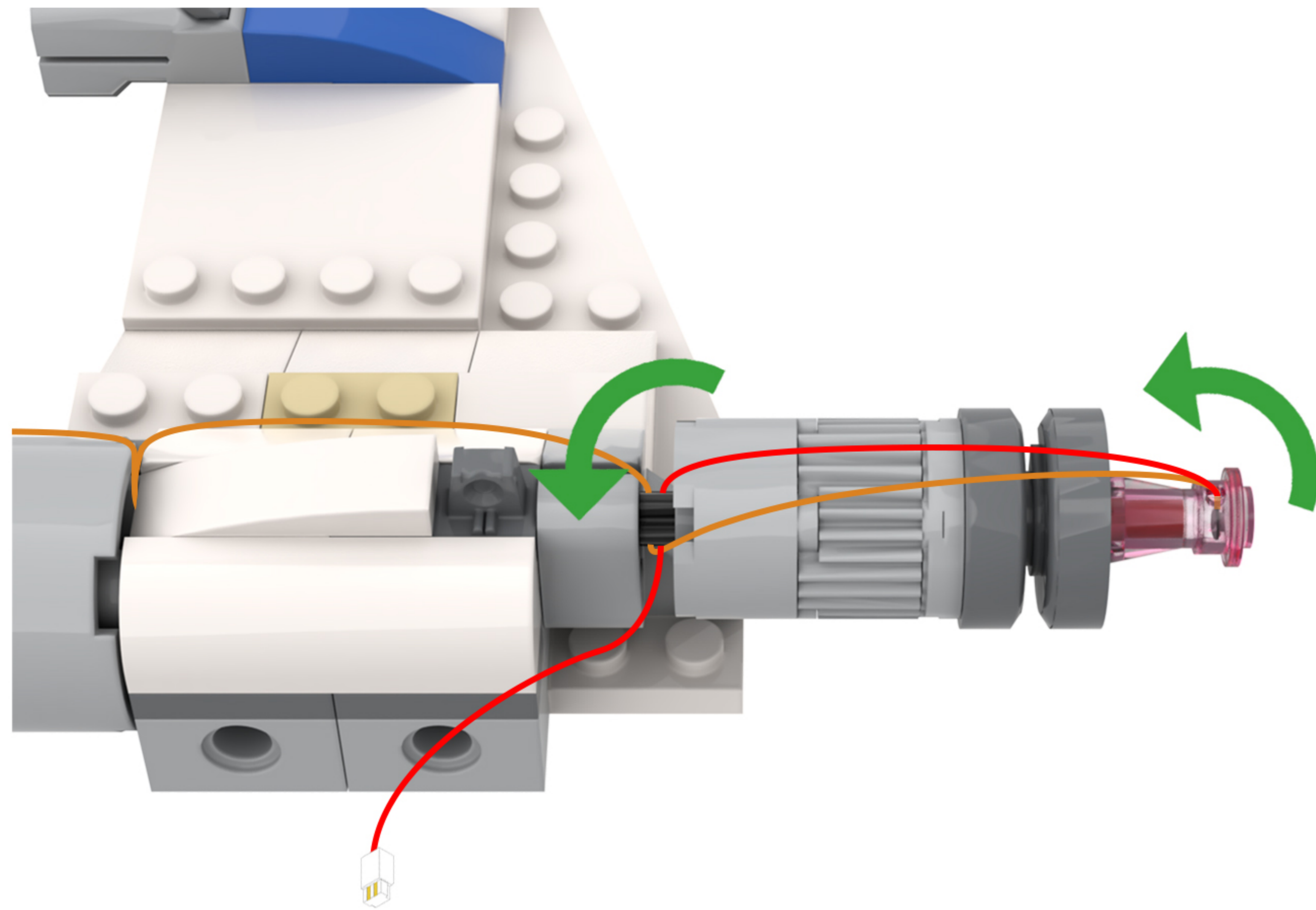

70

EN: Return the building blocks to their original positions so that they press down on the light cord.

DE: Bringen Sie die Bausteine wieder in ihre ursprüngliche Position, sodass sie auf das Lichtkabel drücken.

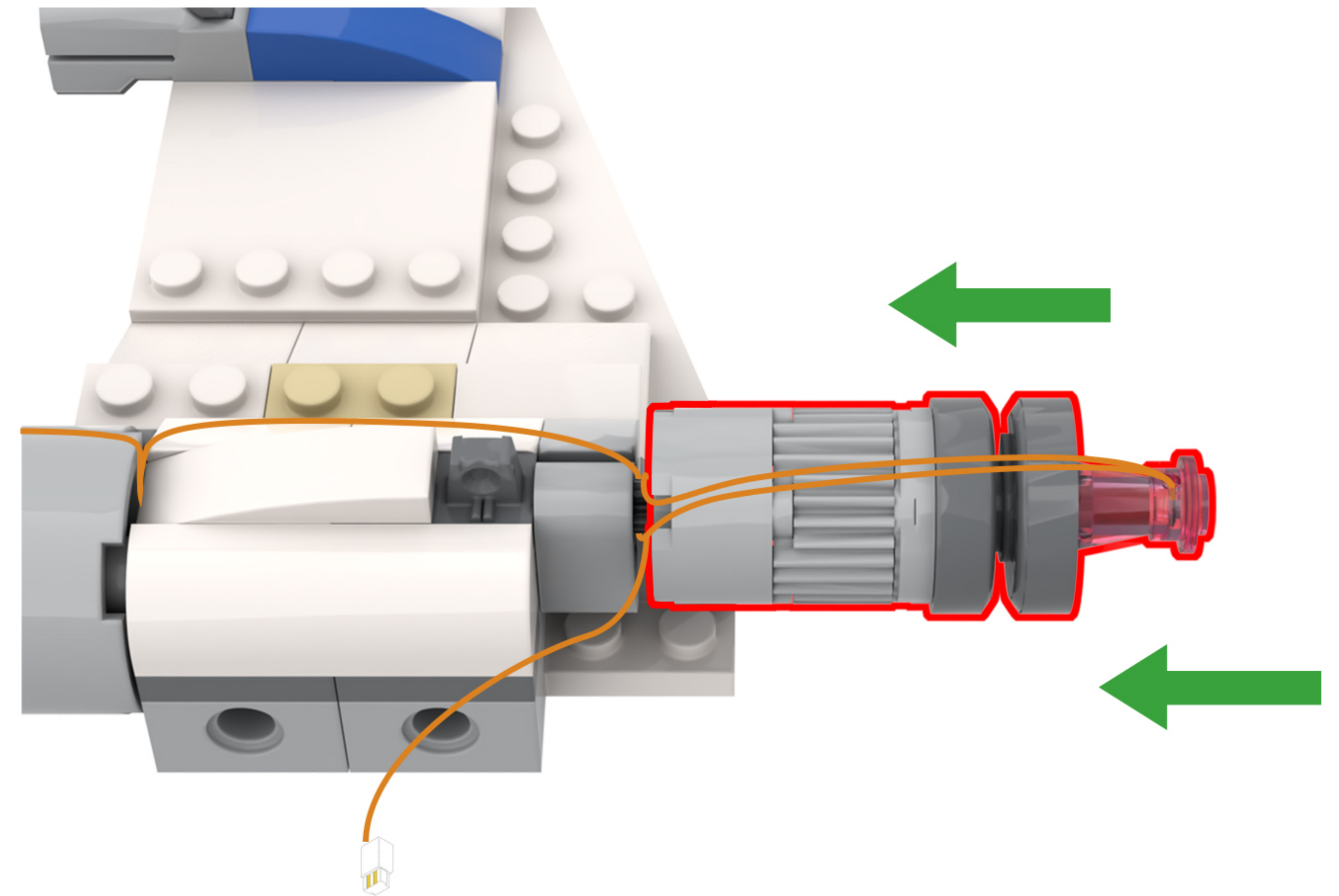

71

EN: Arrange the lighting lines according to the diagram.

DE: Ordnen Sie die Beleuchtungslinien gemäß der Abbildung an.

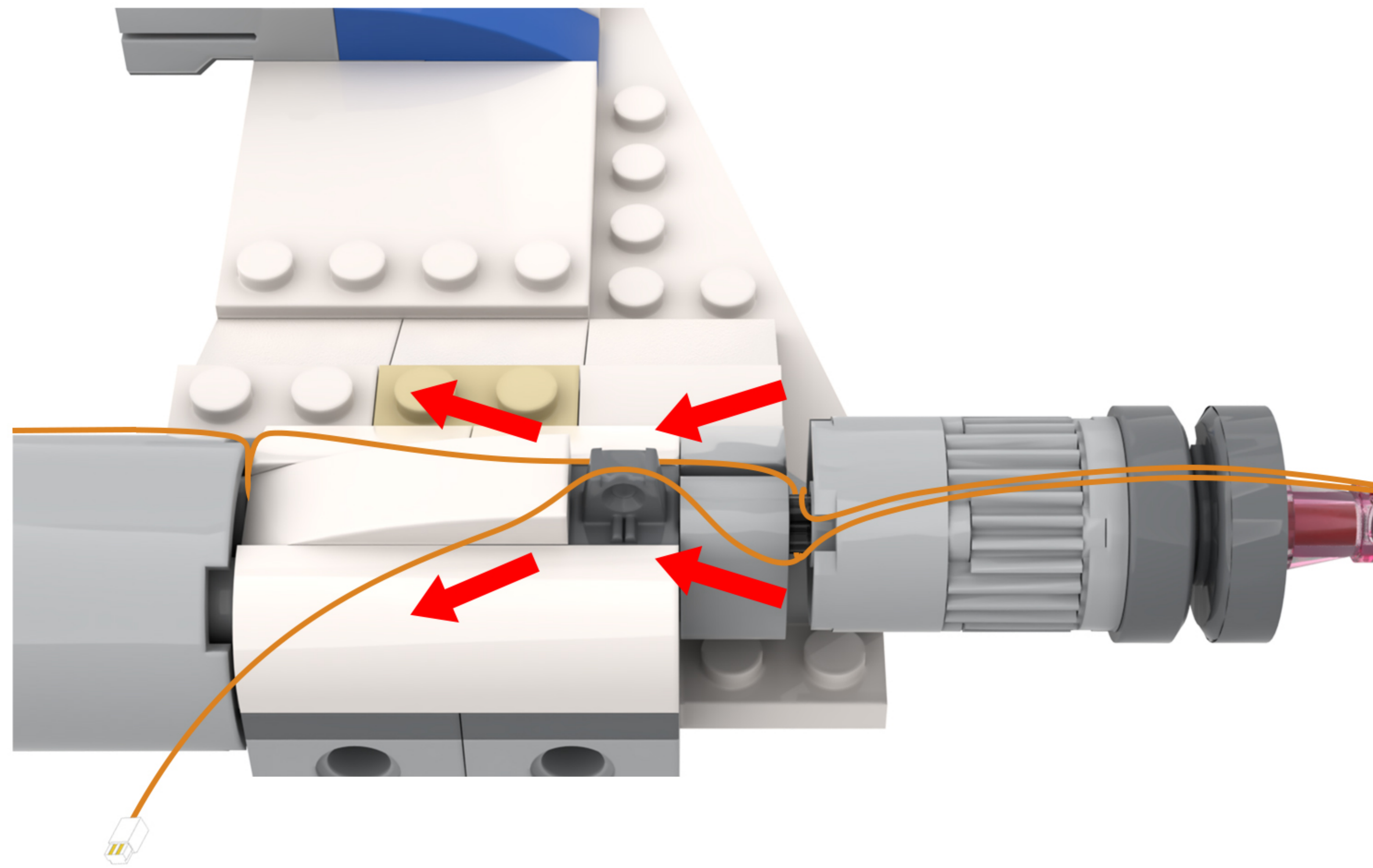

72

EN: Take out the disassembled building blocks and reassemble them.

DE: Nehmen Sie die zerlegten Bausteine heraus und setzen Sie sie wieder zusammen.

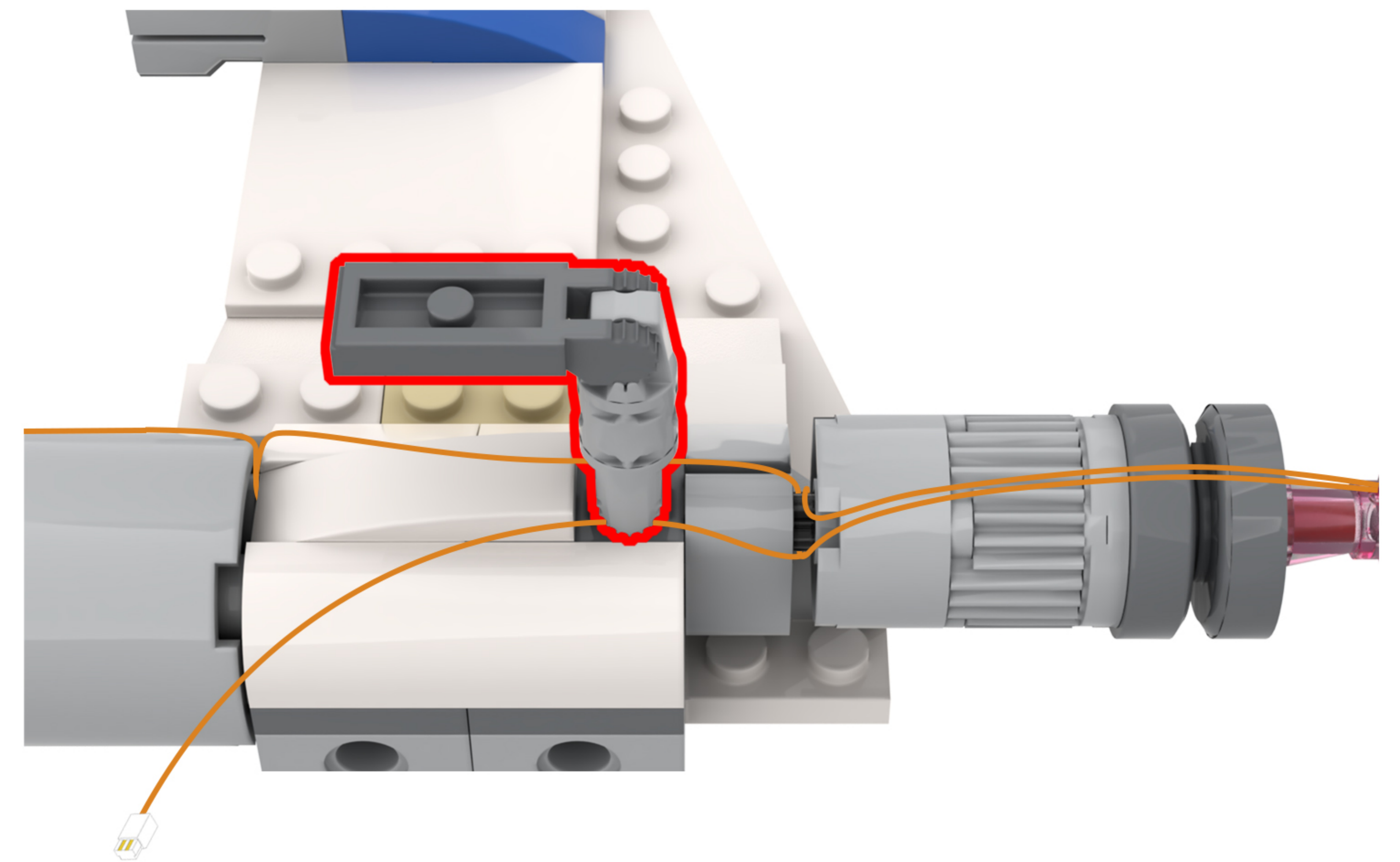
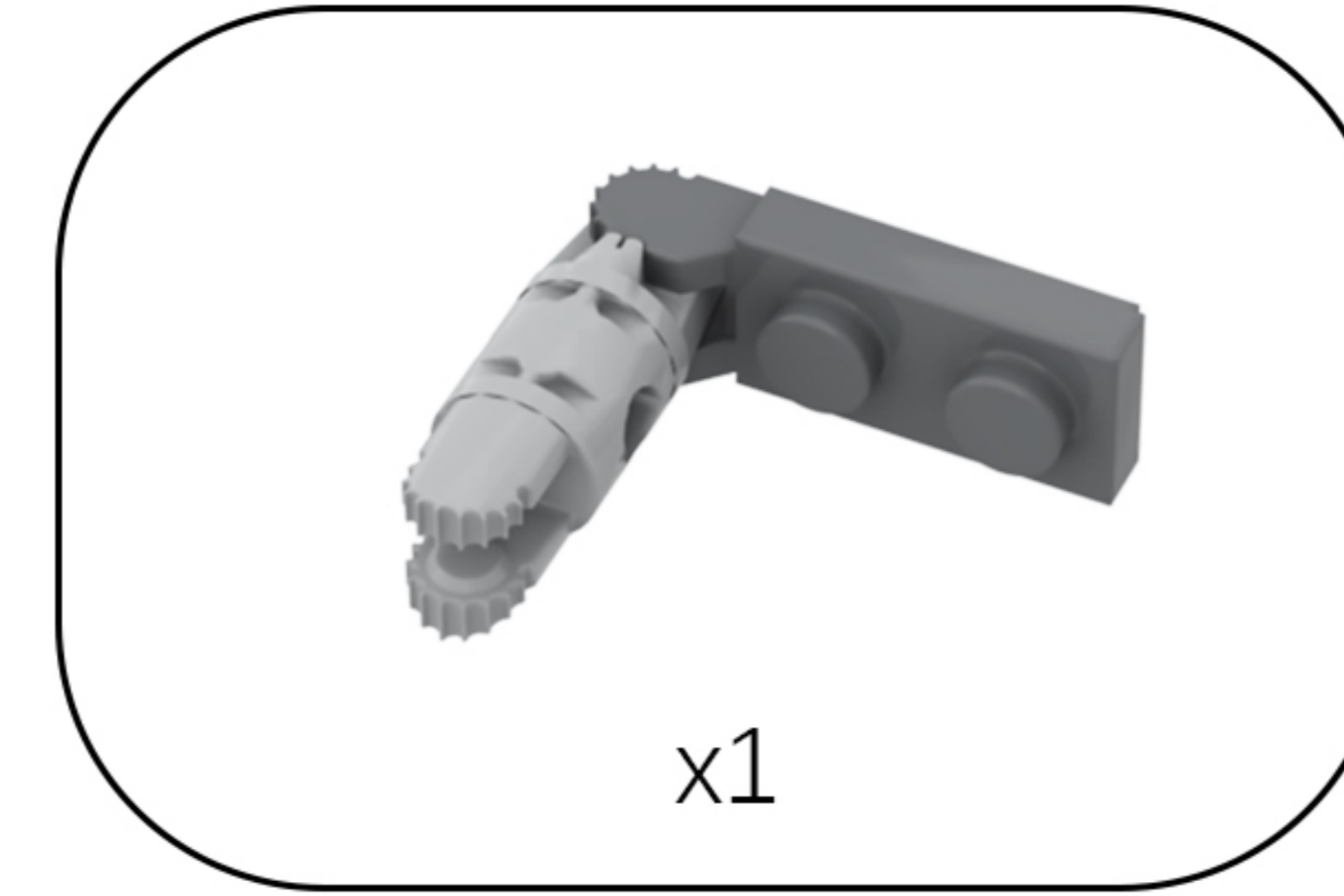

73

EN: The lighting fixtures have been installed on the building blocks.

DE: Die Leuchten wurden an den Gebäudeteilen angebracht.

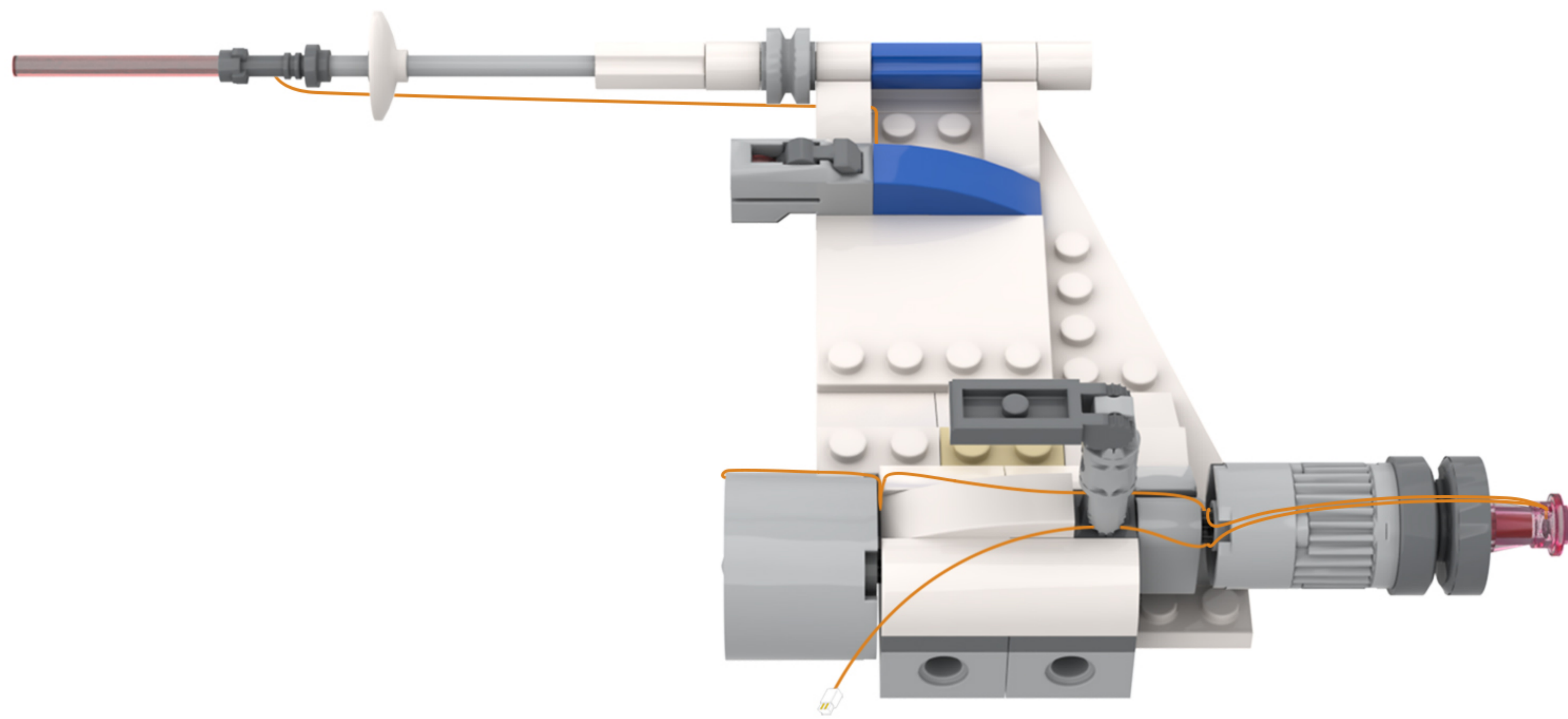

74

EN: Repeat the steps above to install lighting on the other building block.

DE: Wiederholen Sie die oben genannten Schritte, um die Beleuchtung am anderen Baustein anzubringen.

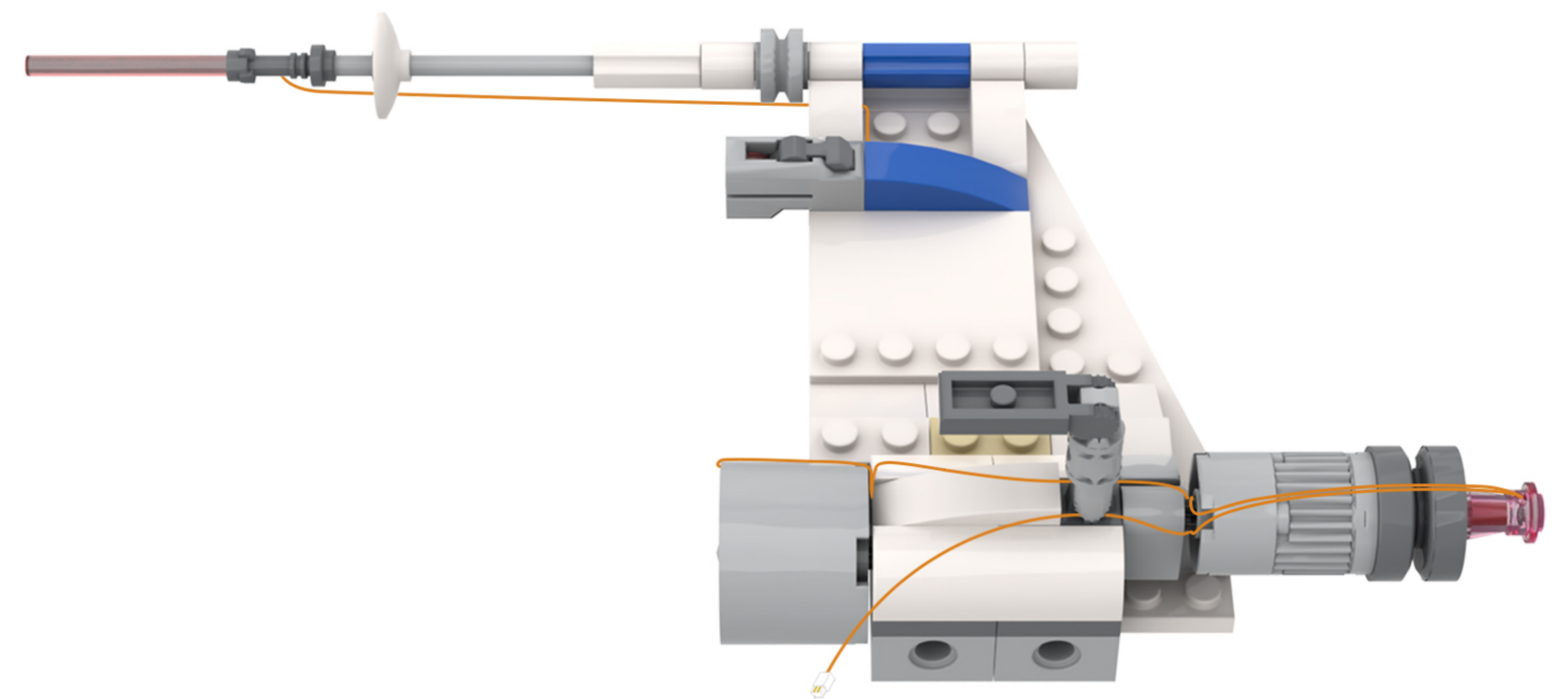
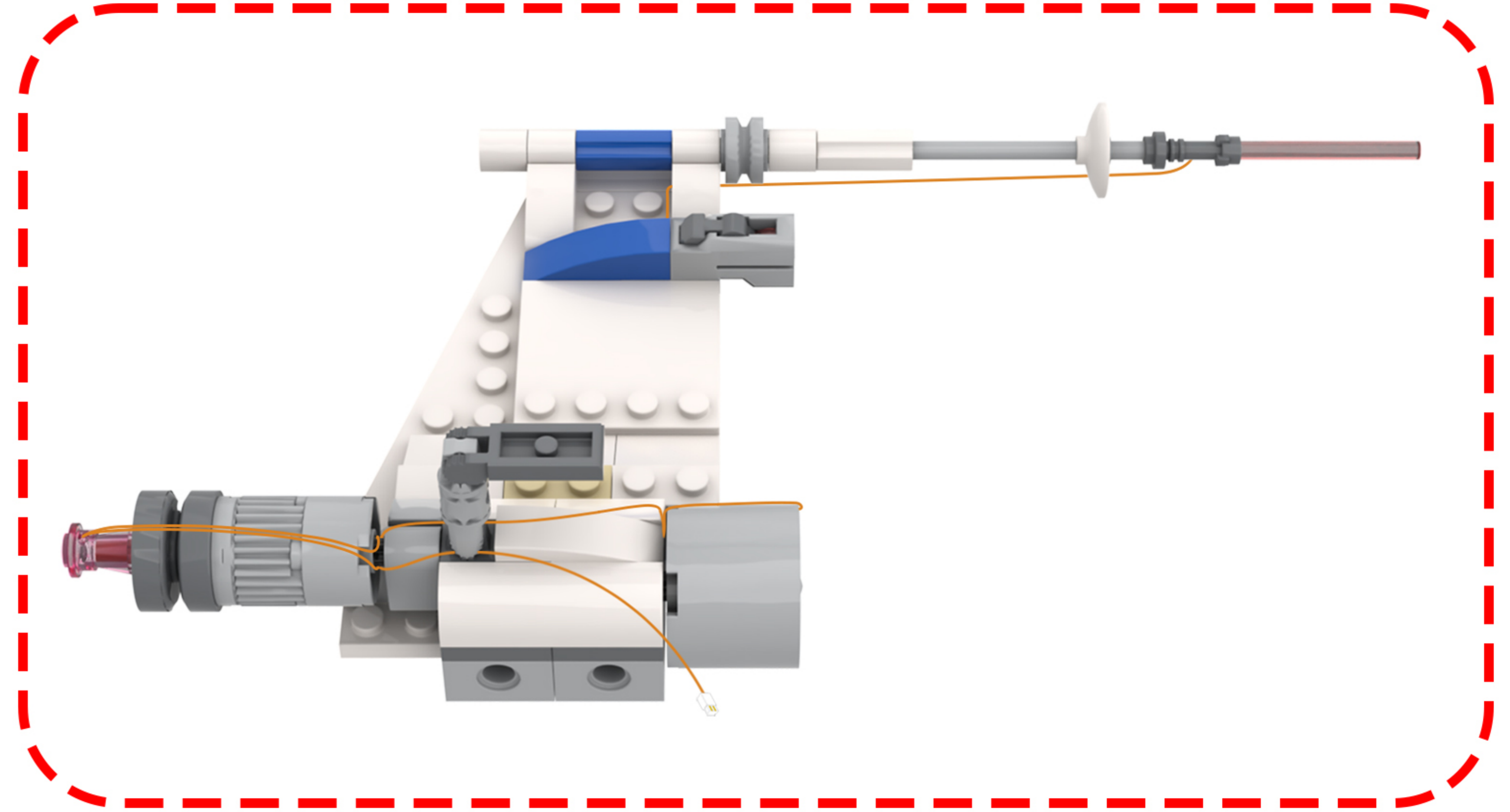

75

EN: Return to the model and flip it to its bottom face.

DE: Kehren Sie zum Modell zurück und drehen Sie es auf die Unterseite.

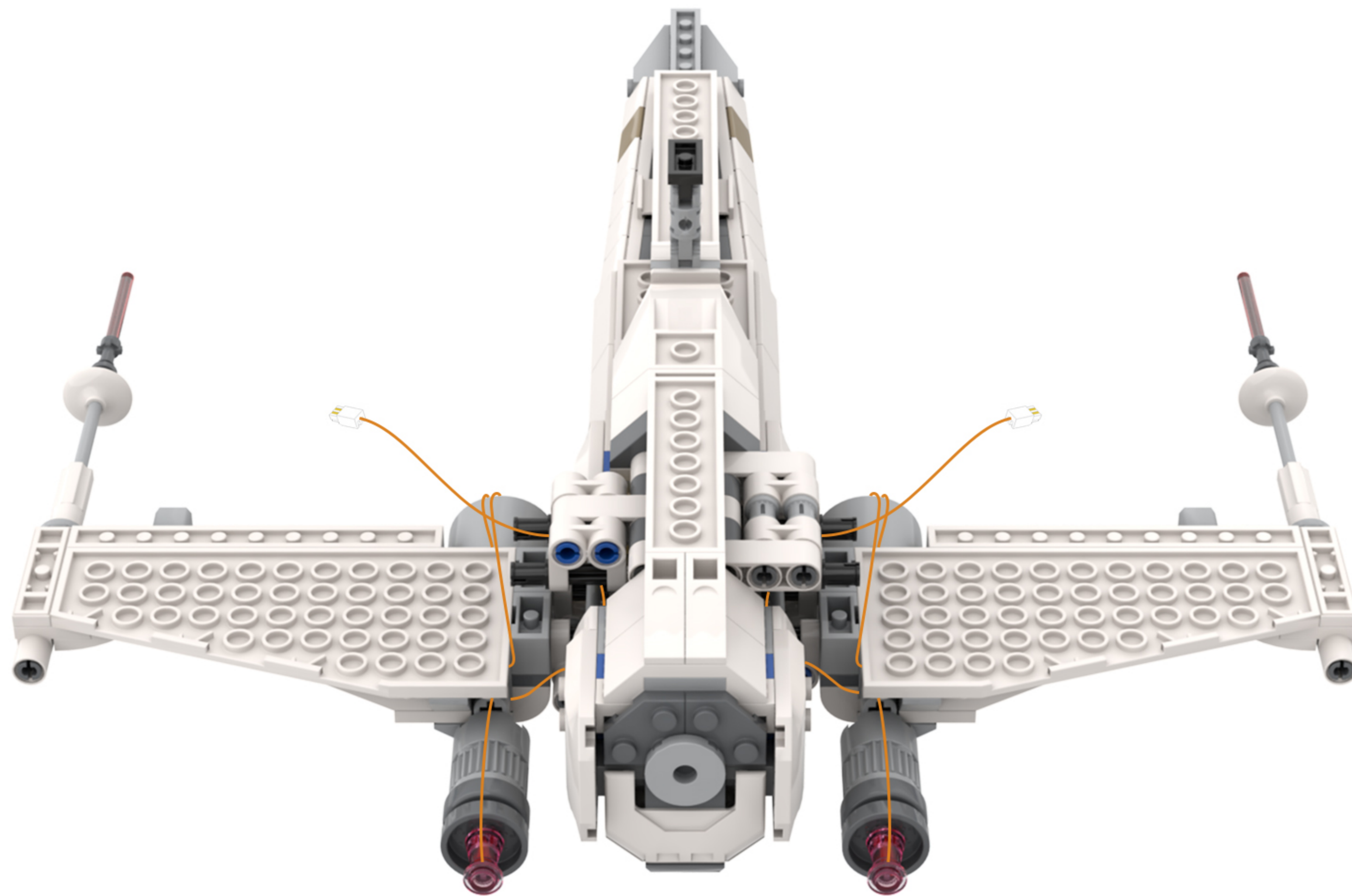

76

EN: Take out the disassembled building blocks and reassemble them in order.

DE: Nehmen Sie die zerlegten Bausteine heraus und setzen Sie sie der Reihe nach wieder zusammen.

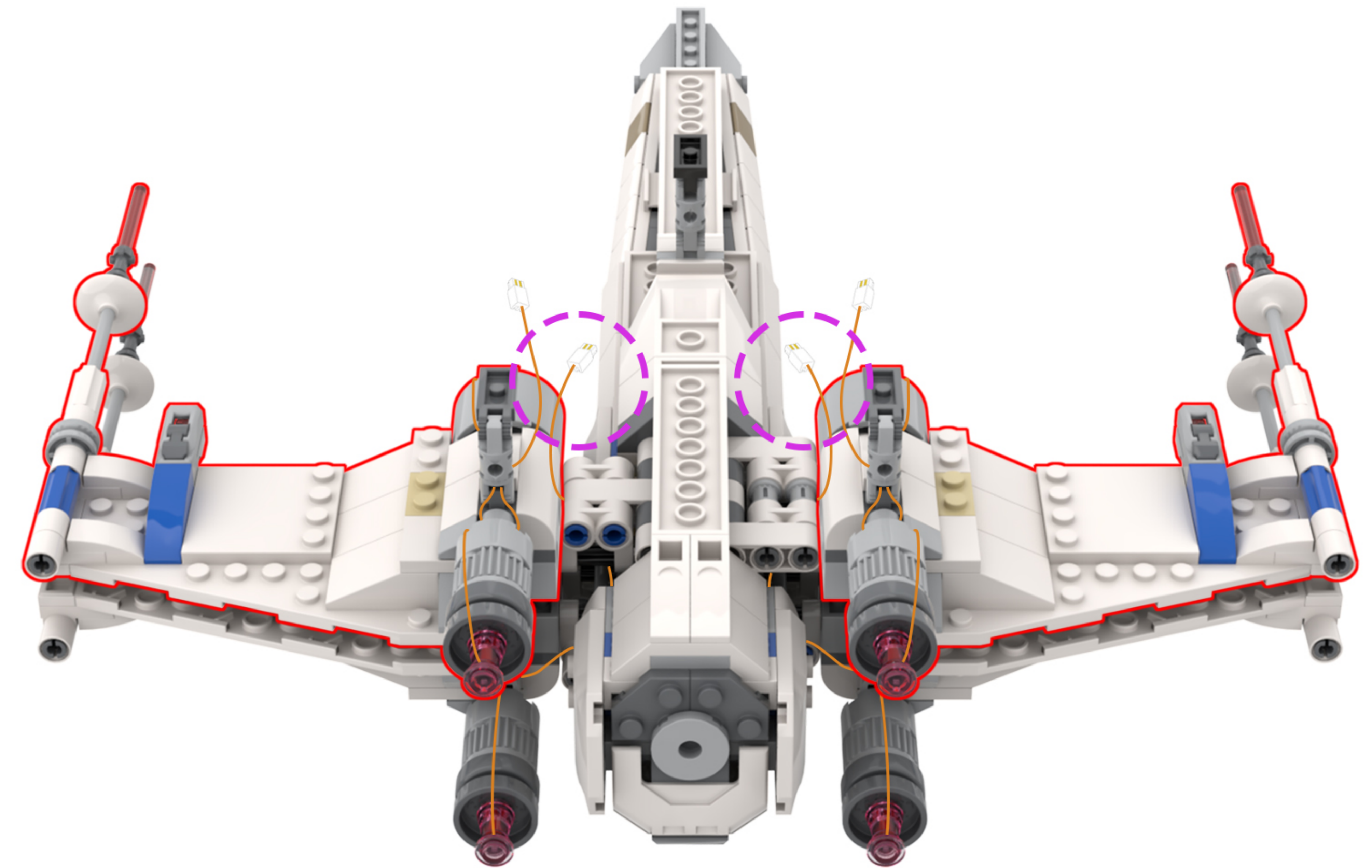
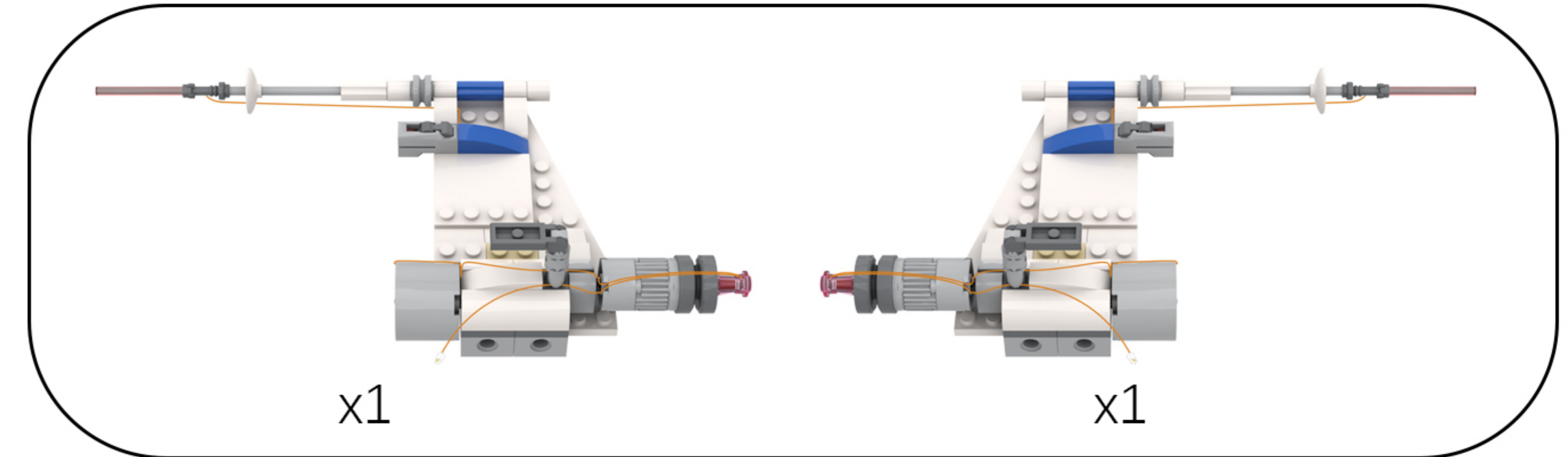

Note: Route all light cables to the bottom of the model.

77

EN: Locate the two light wires in the diagram.

DE: Suchen Sie die beiden Lichtkabel in der Abbildung.

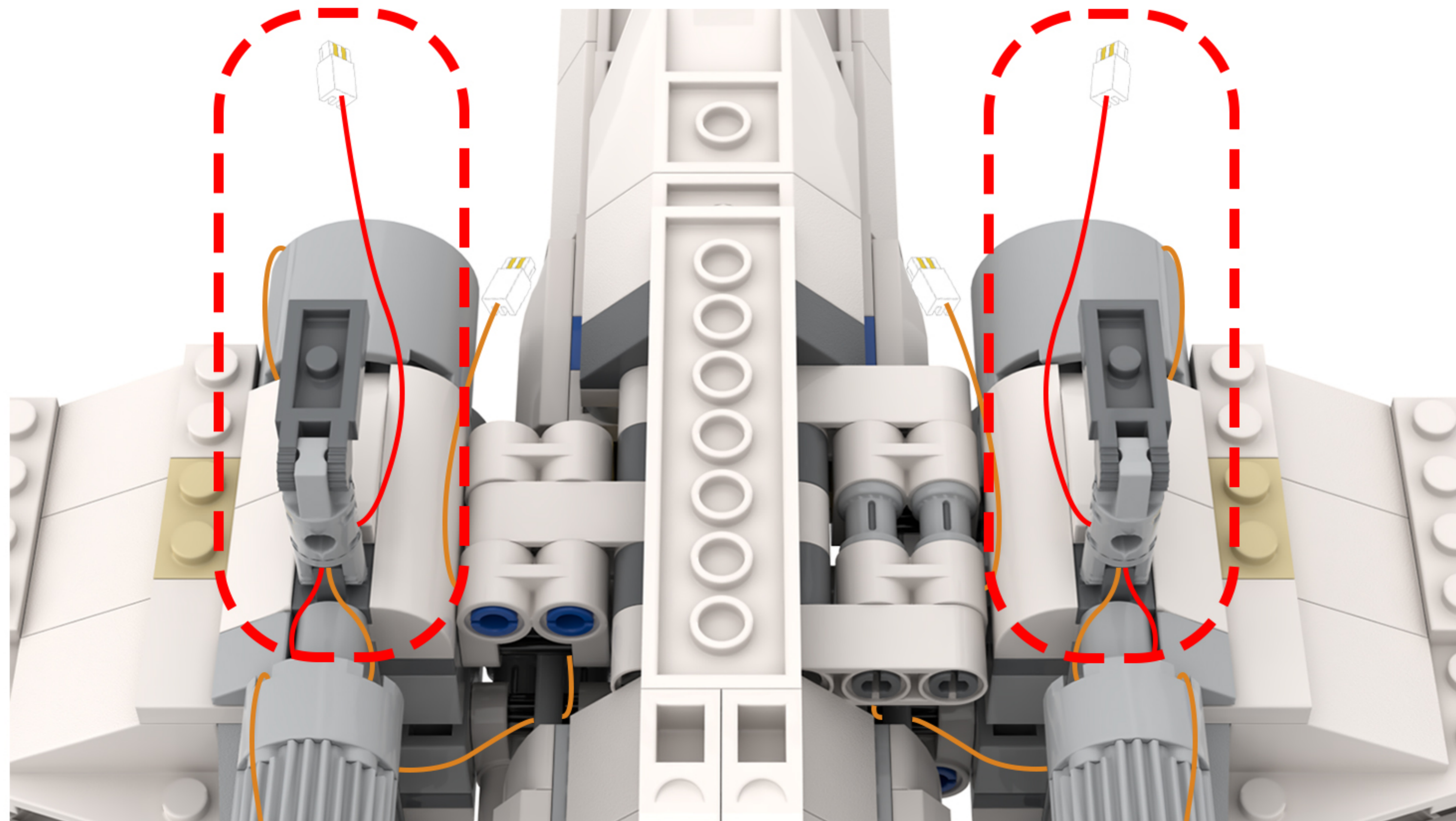

78

EN: Thread the wires from the two string lights through the gaps in the building blocks to the other side.

DE: Führen Sie die Kabel der beiden Lichterketten durch die Öffnungen in den Bausteinen auf die andere Seite.

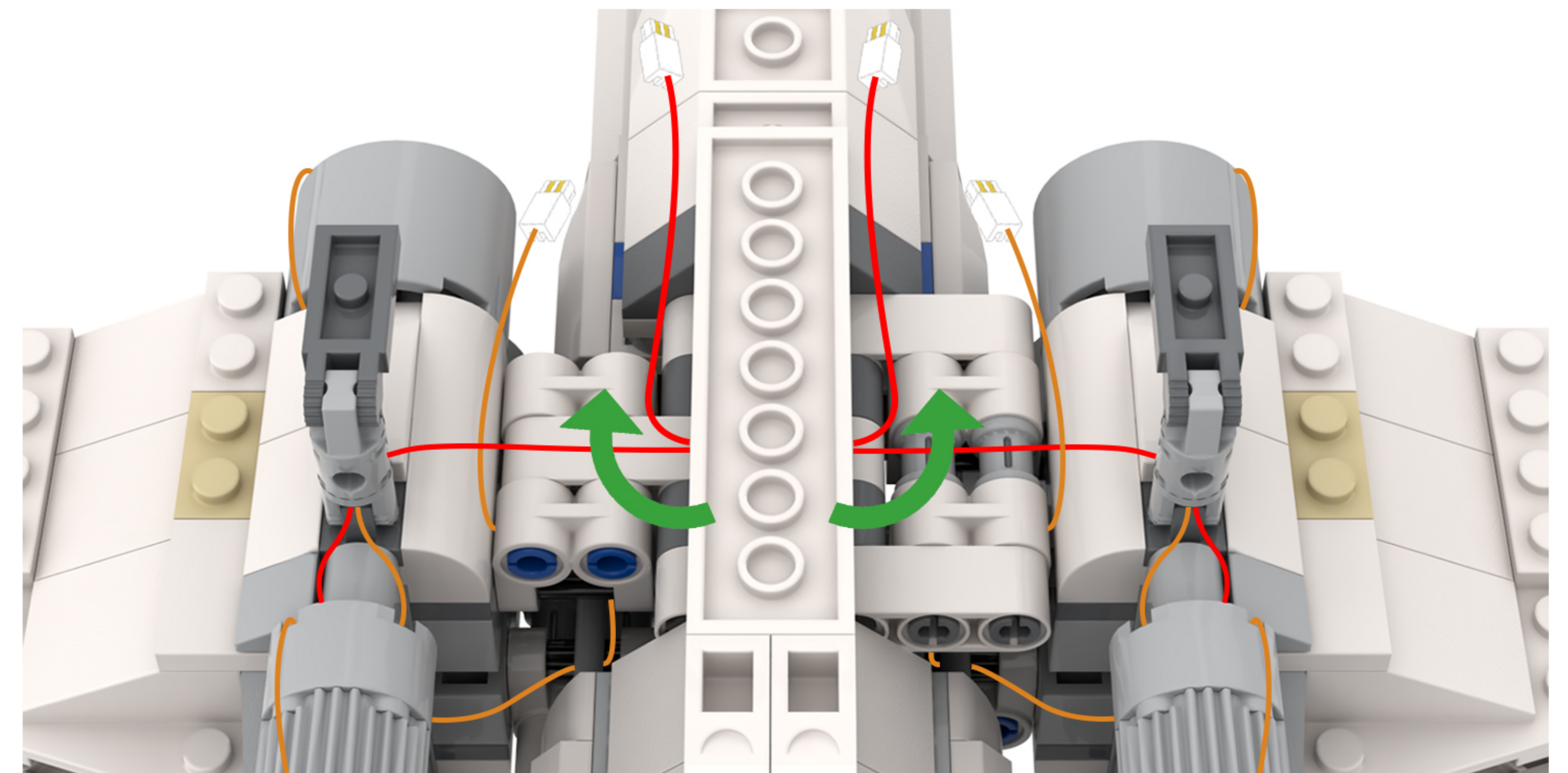
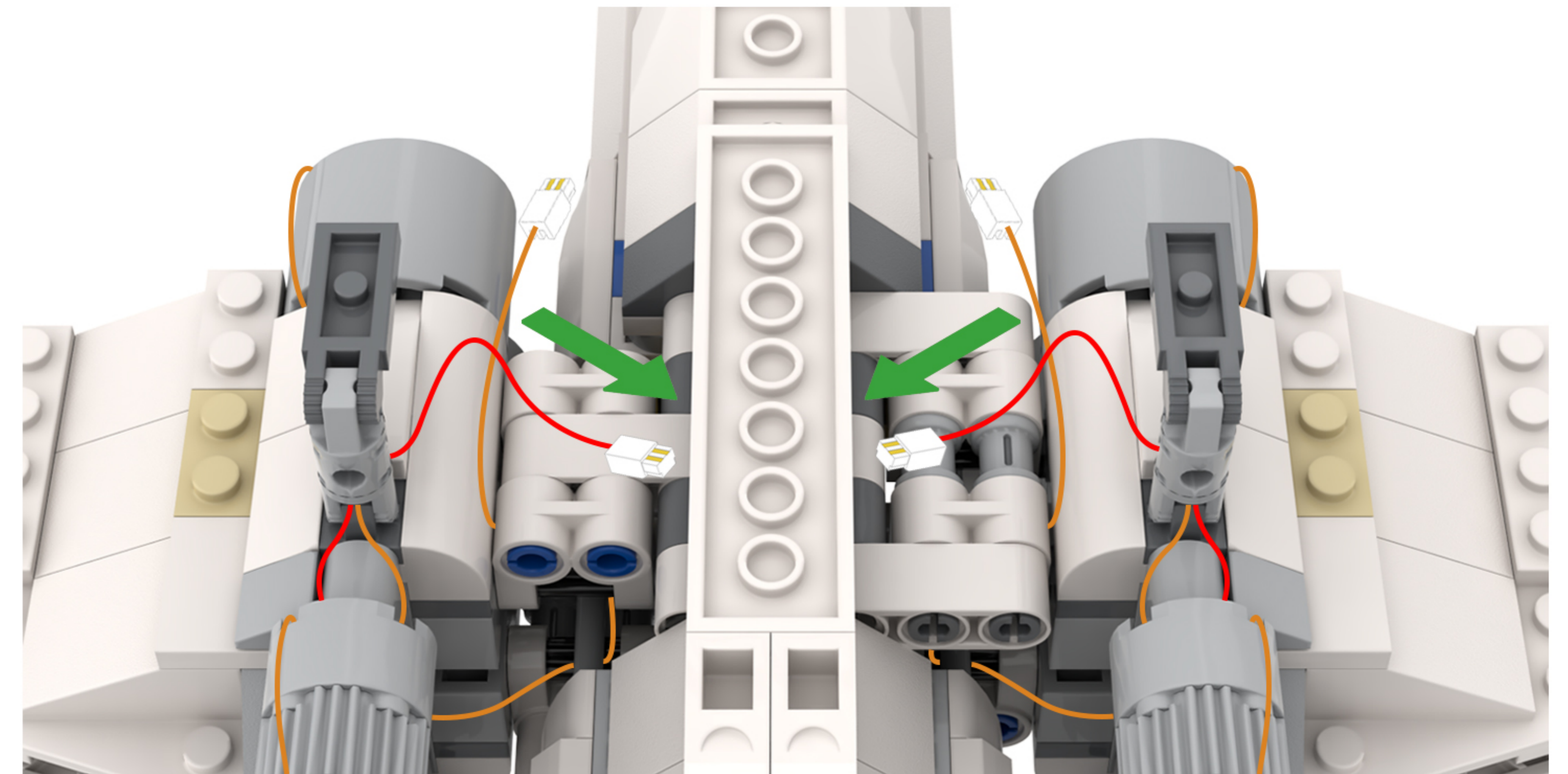

79

EN: Twist the wires from the two string lights together.

DE: Verdrehen Sie die Drähte der beiden Lichterketten miteinander.

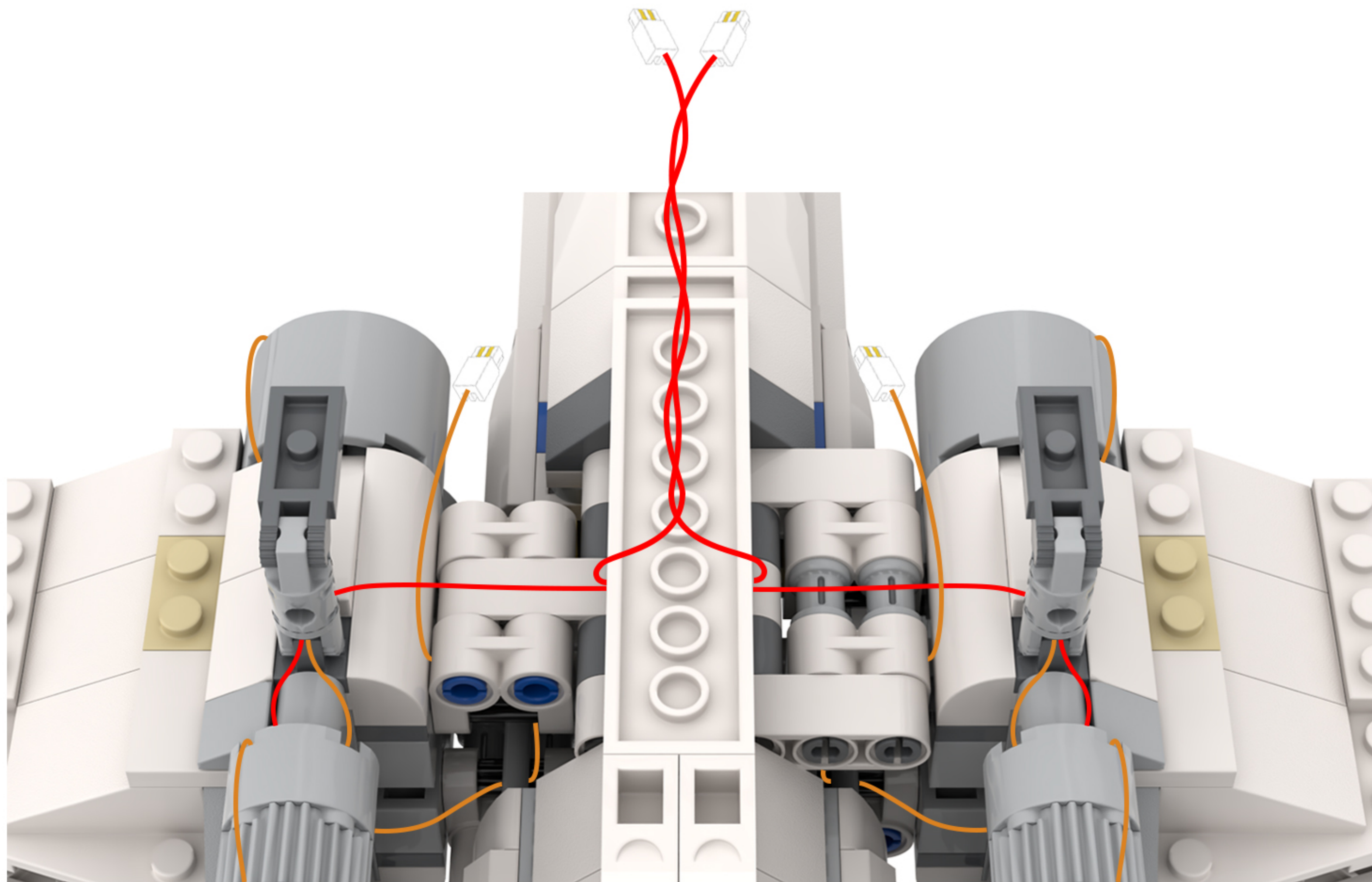

80

EN: Flip the model to restore it to its original state.

DE: Drehen Sie das Modell um, um es in seinen ursprünglichen Zustand zurückzusetzen.

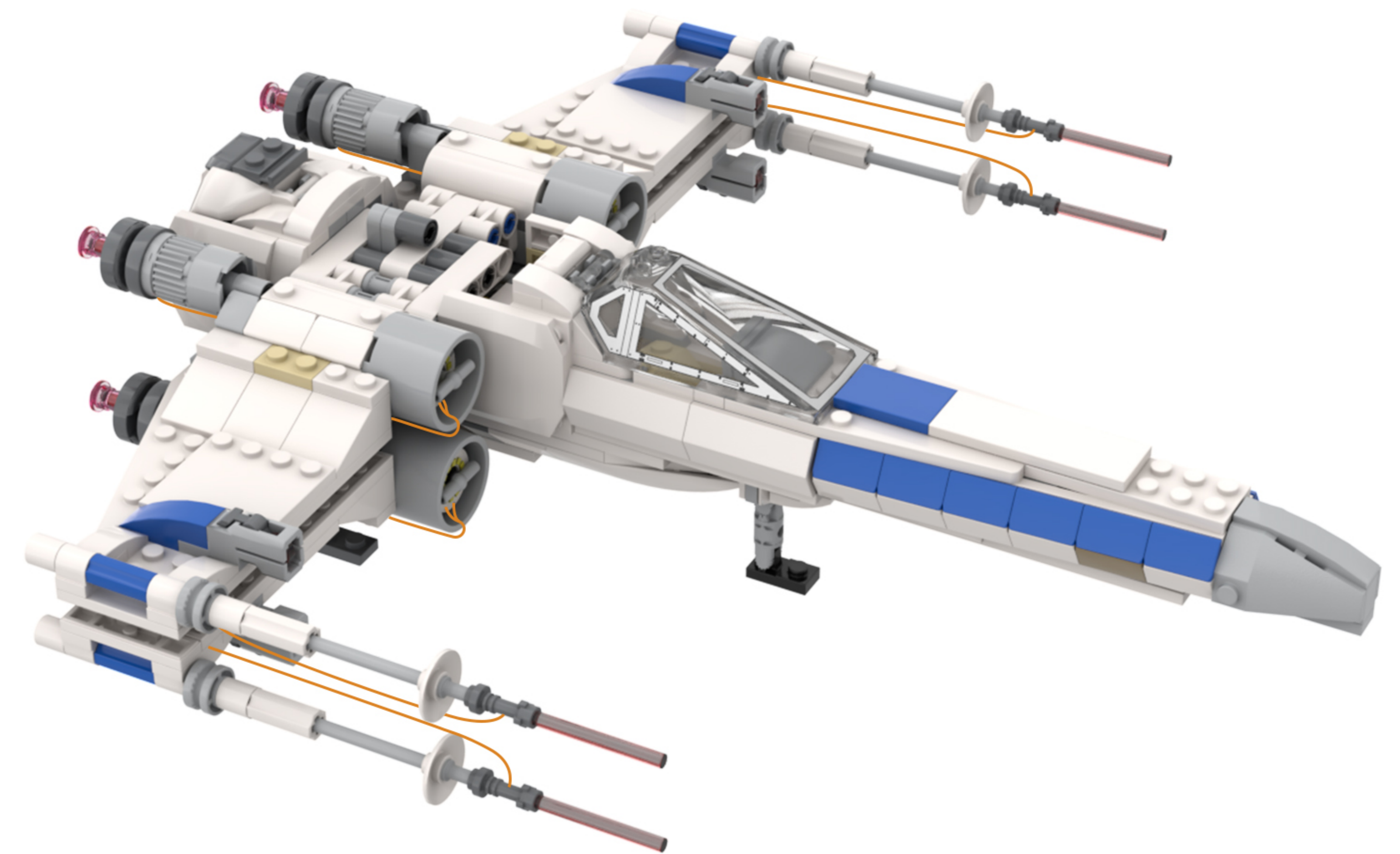
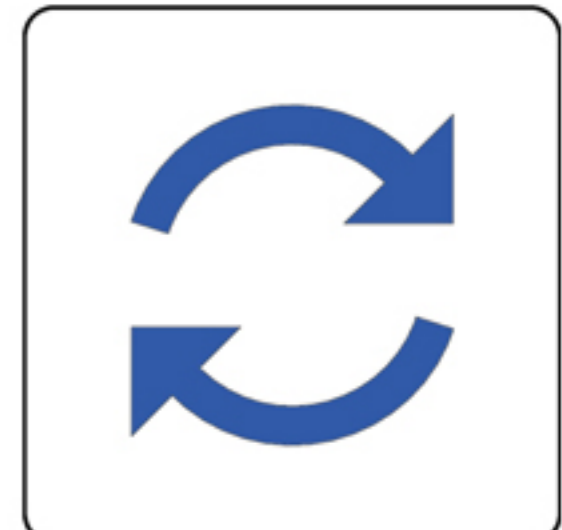

81

EN: Adjust your perspective.

DE: Ändern Sie Ihre Perspektive.

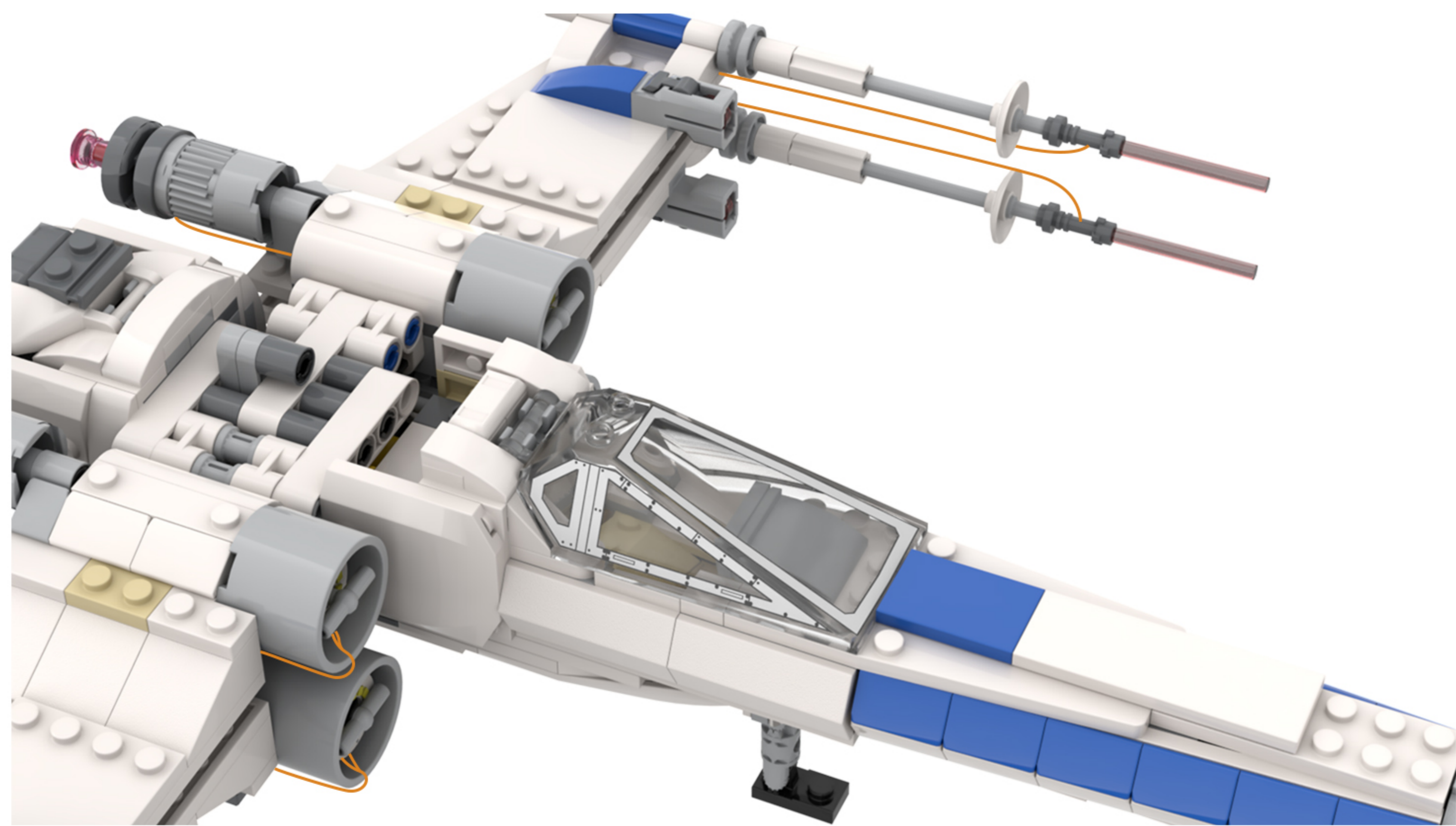

82

EN: Rotate to open the building block.

DE: Drehen Sie den Baustein, um ihn zu öffnen.

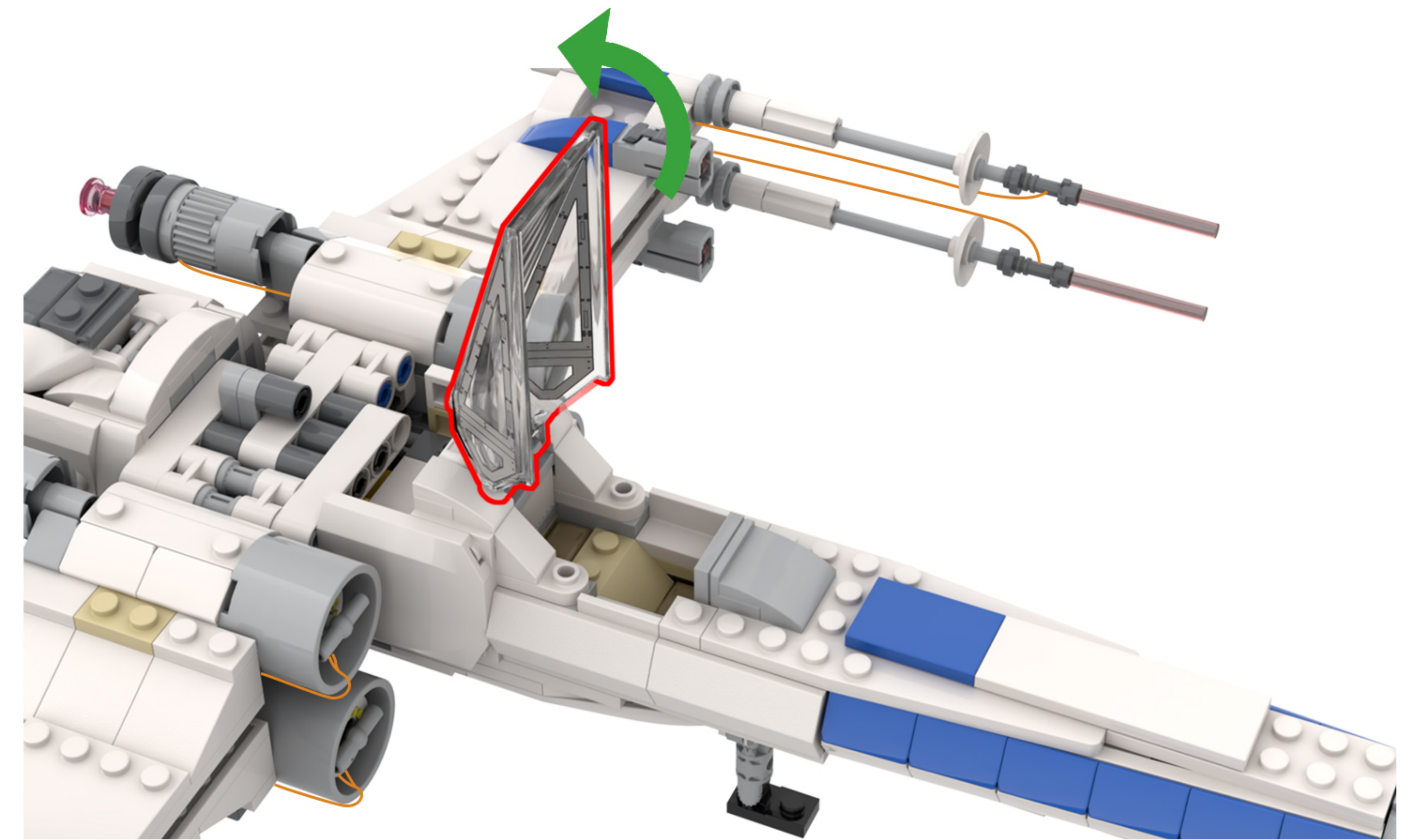

83

EN: Adjust your perspective.

DE: Ändern Sie Ihre Perspektive.

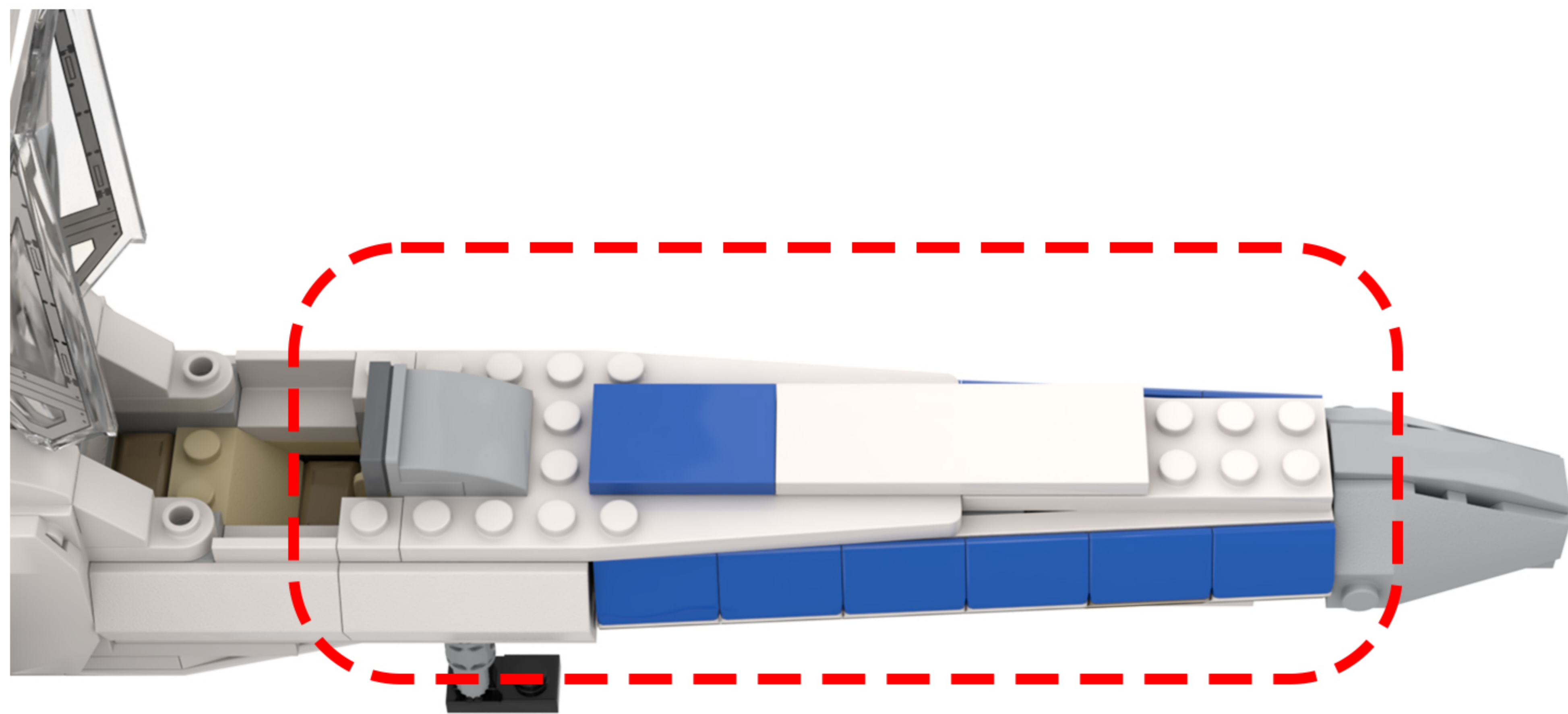

84

EN: Split as shown in the figure.

DE: Wie in der Abbildung gezeigt, teilen Sie es auf.

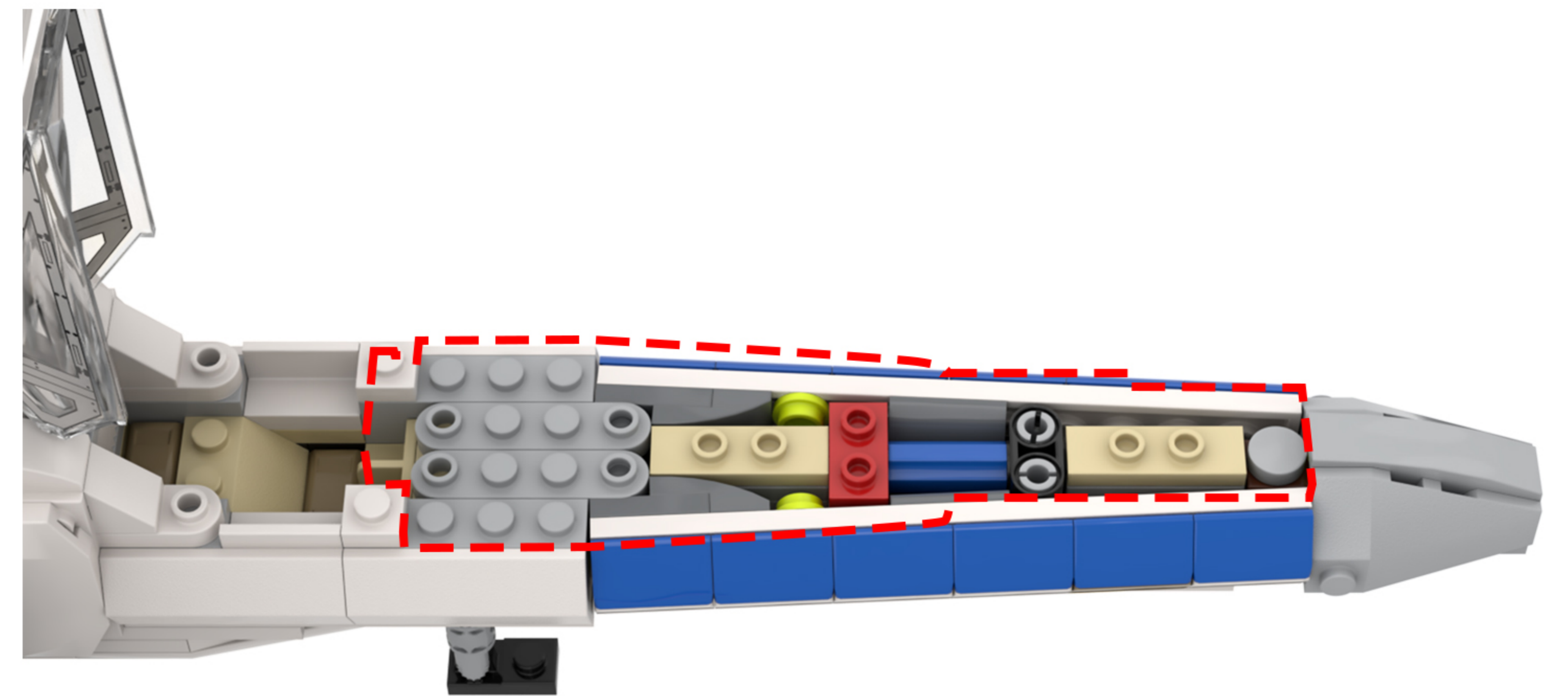
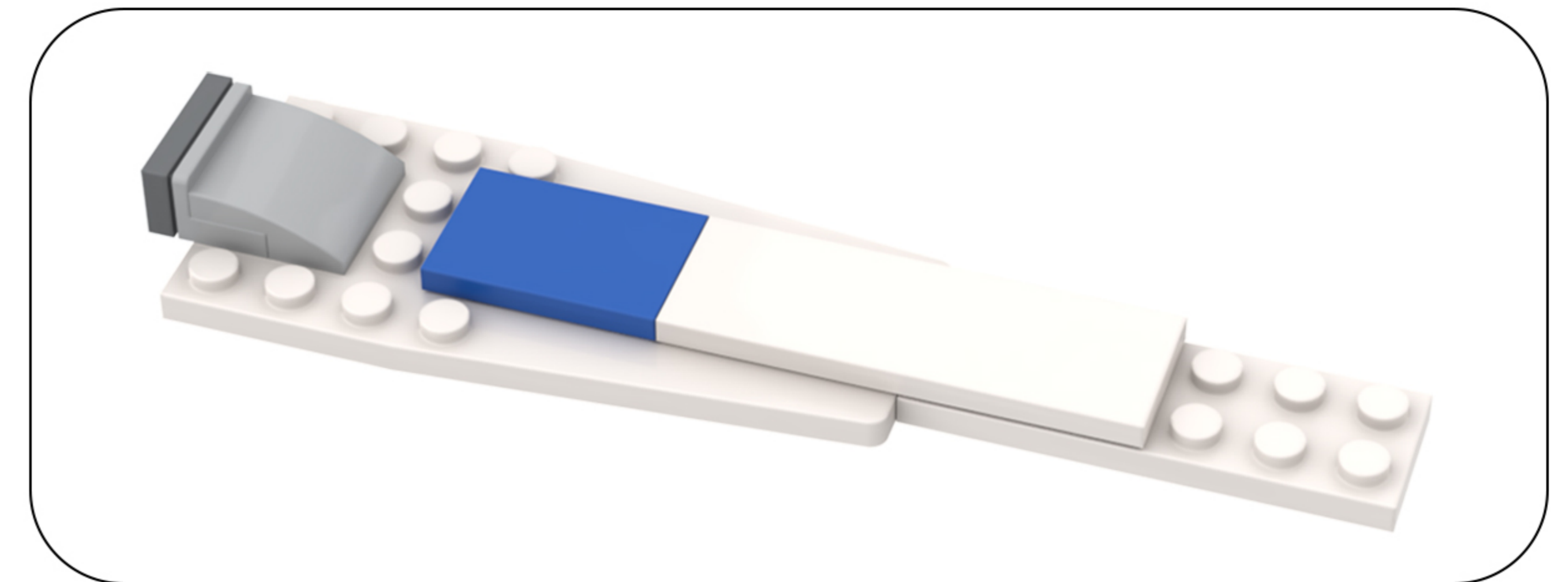

85

EN: Split as shown in the figure.

DE: Wie in der Abbildung gezeigt, teilen Sie es auf.

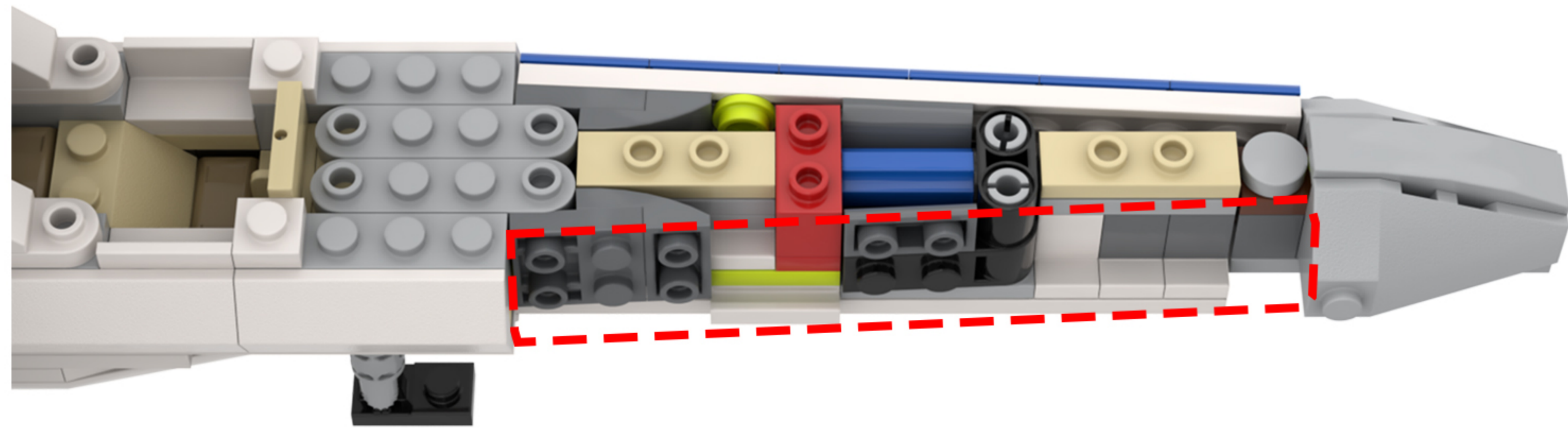
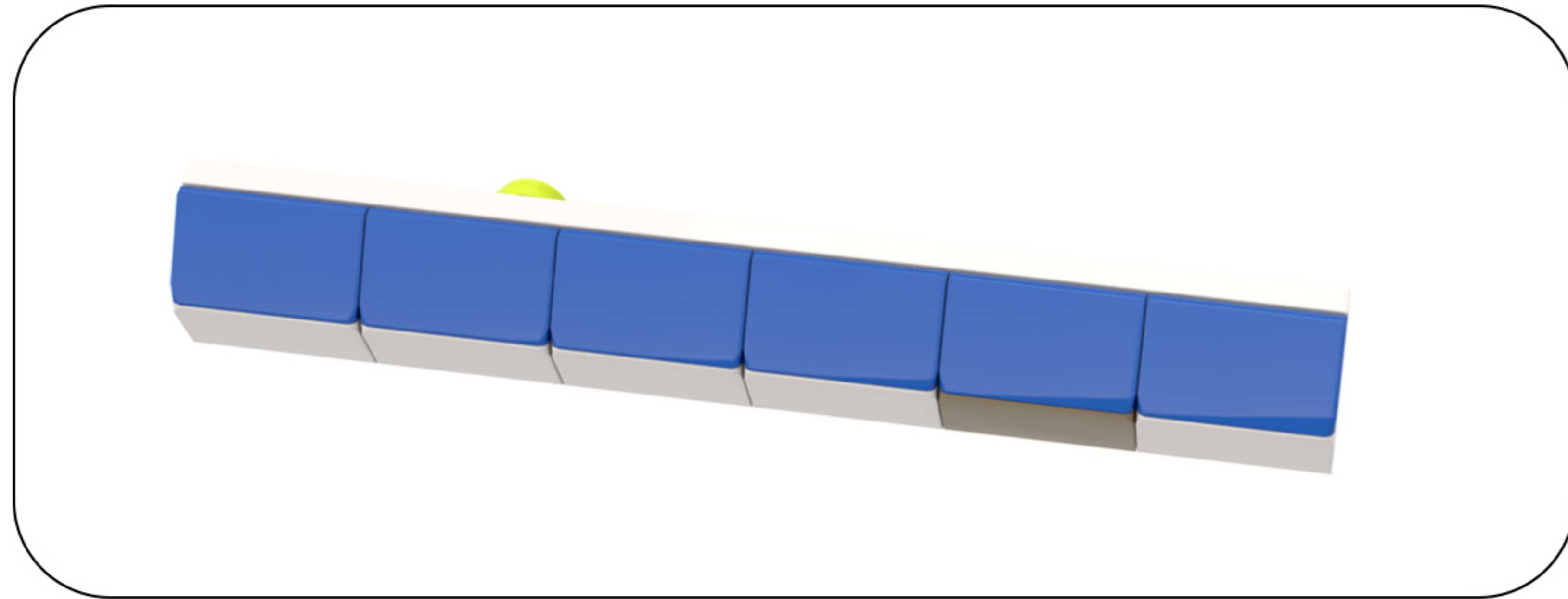

86

EN: Take the string of lights out of Bag 3, untie the zip tie, and locate the decorative lights on the string.

DE: Nimm die Lichterkette aus Beutel 3, löse den Kabelbinder und suche die dekorativen Lichter an der Kette.

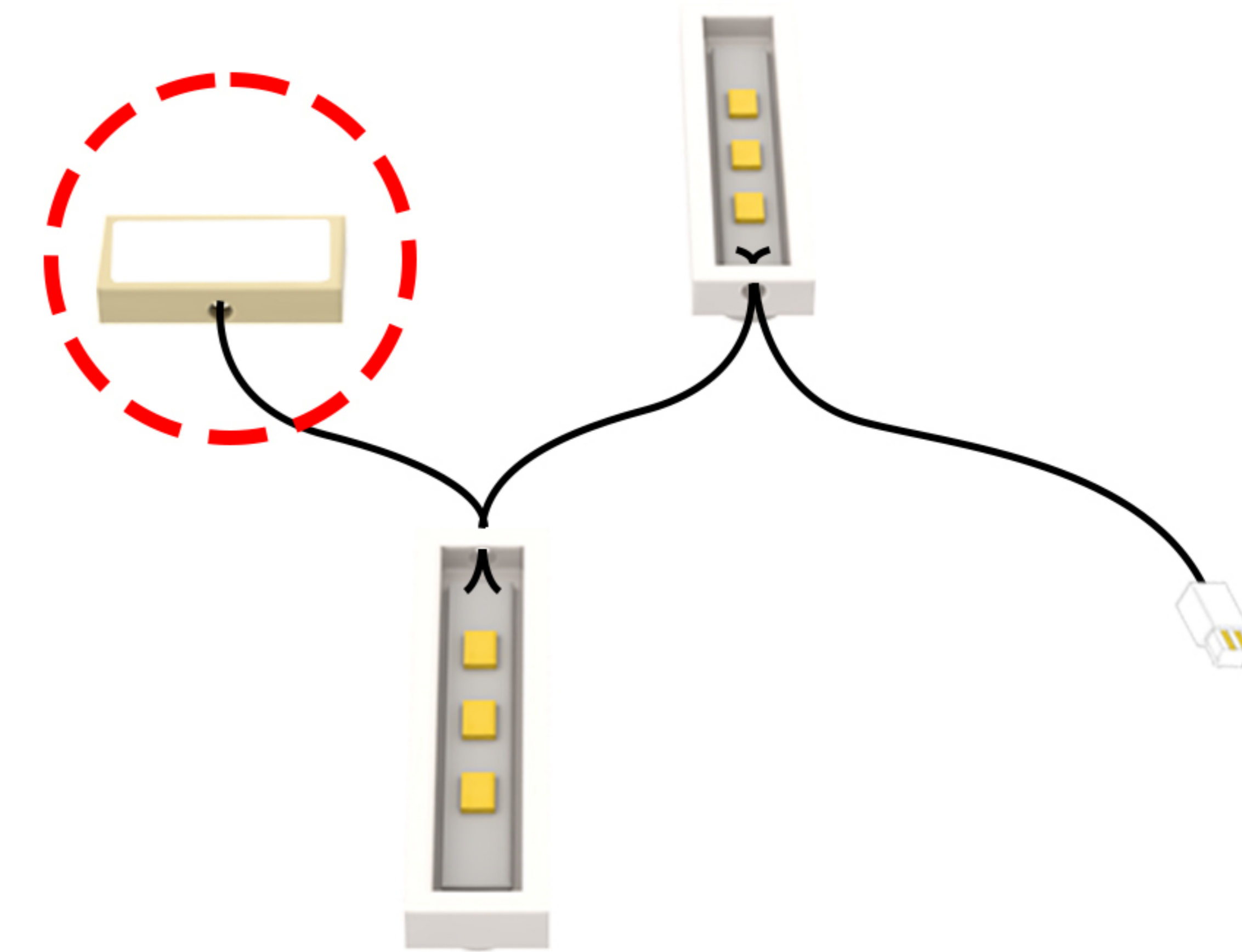
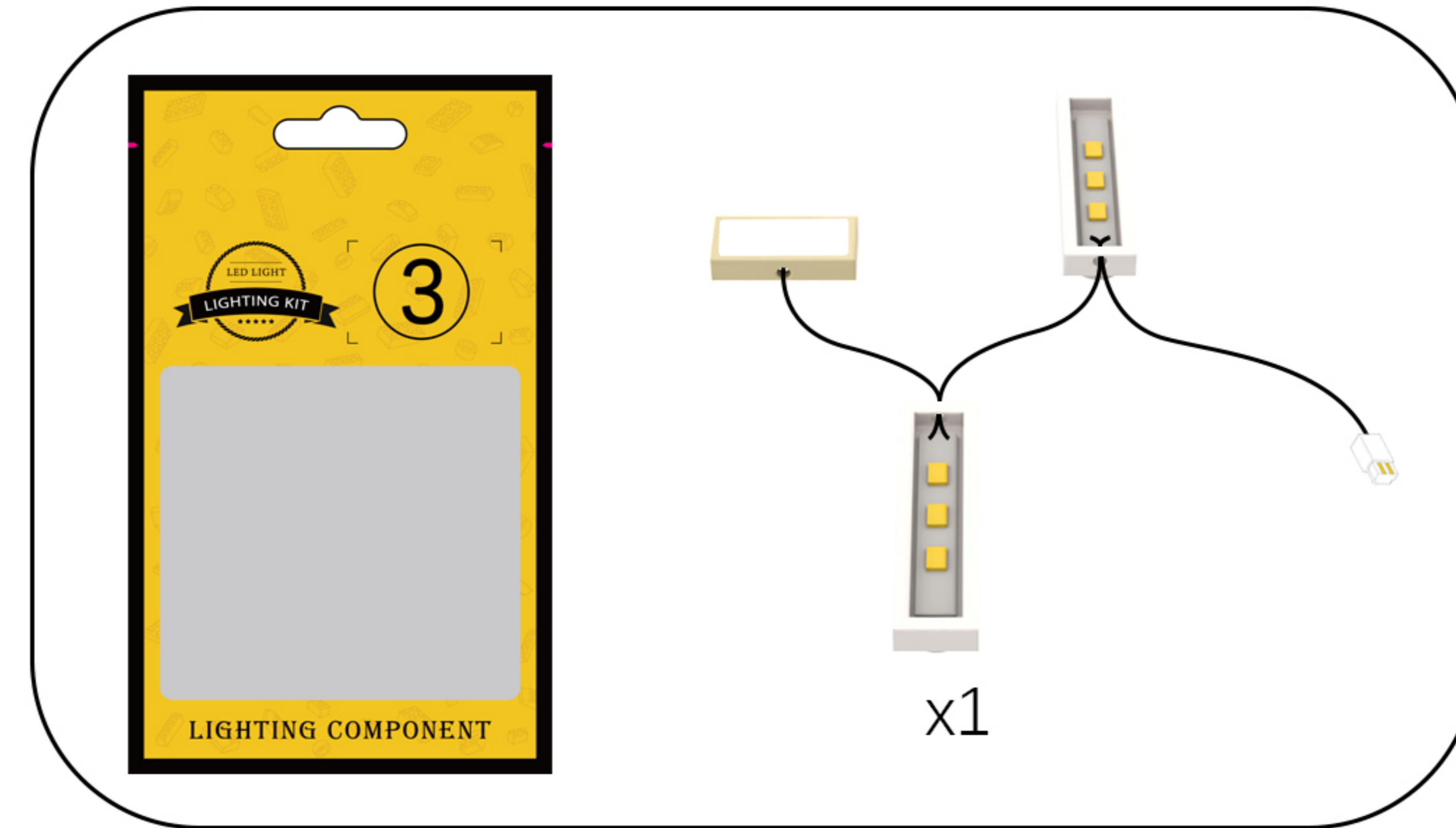

87

EN: Peel off the adhesive backing of the light fixture and attach it to the indicated location.

DE: Ziehen Sie die Klebefolie von der Leuchte ab und befestigen Sie sie an der angegebenen Stelle.

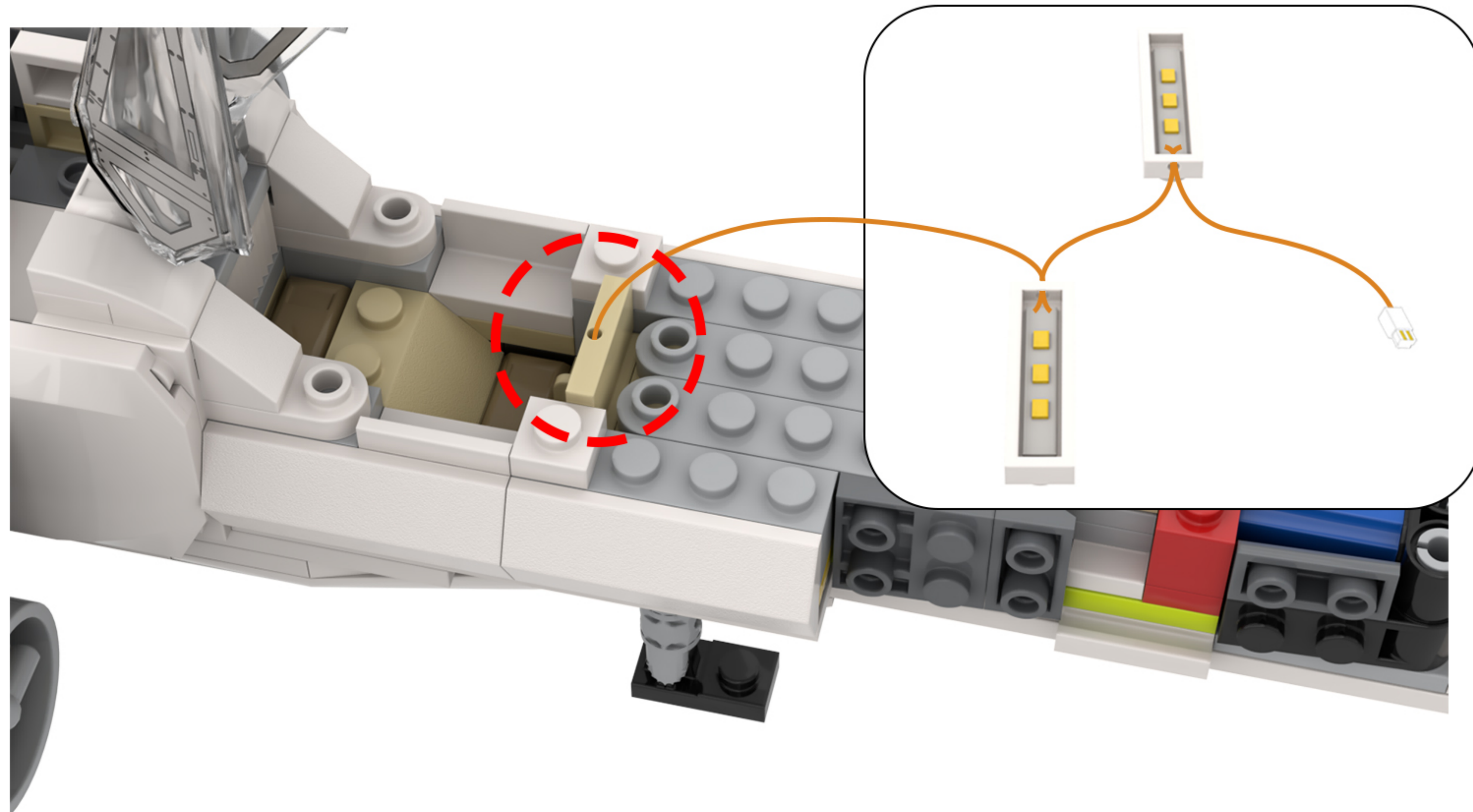

88

EN: Find the wire in the string of lights.

DE: Finde den Draht in der Lichterkette.

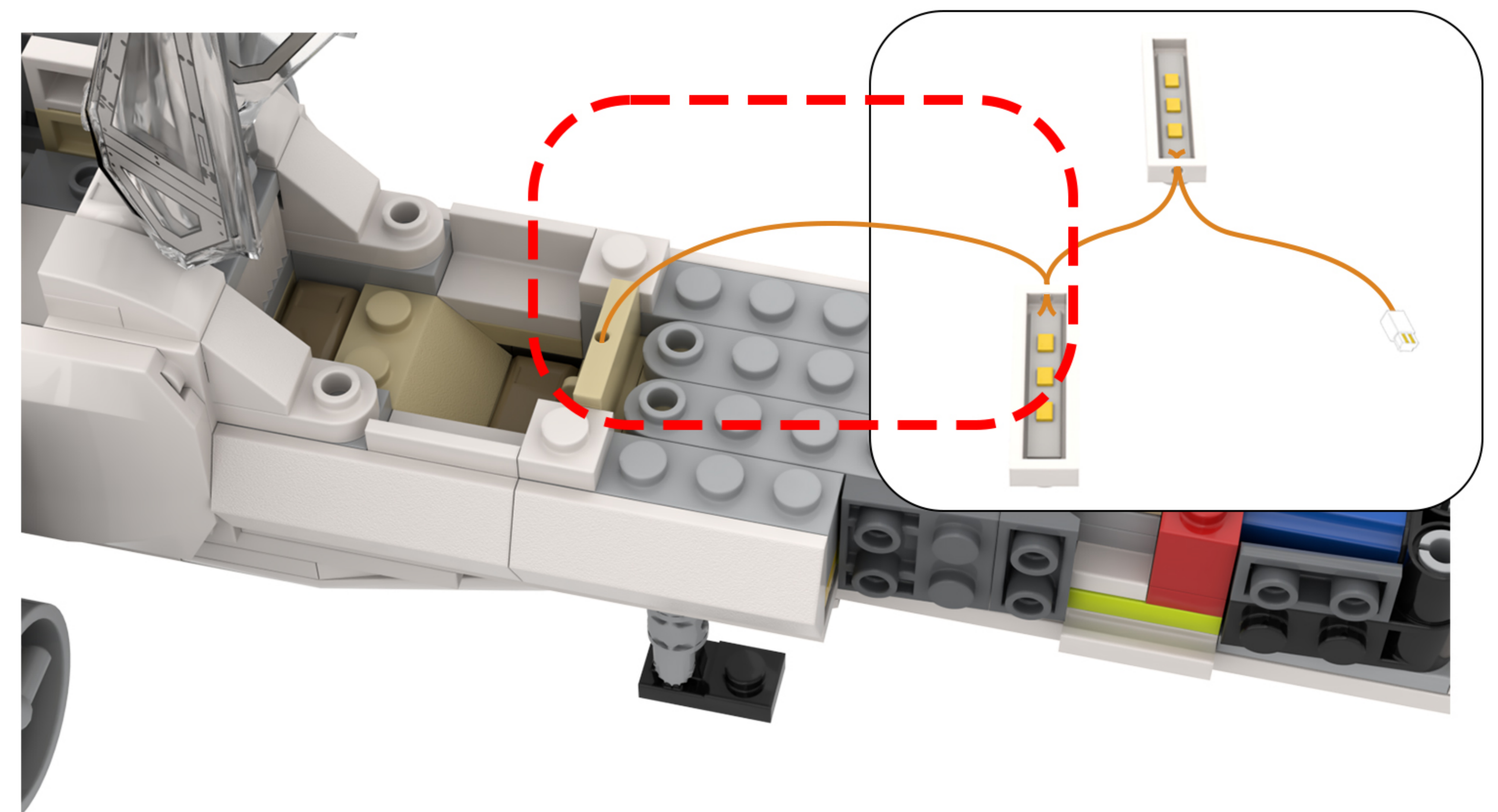

89

EN: Arrange the lighting lines according to the diagram.

DE: Ordnen Sie die Beleuchtungslinien gemäß der Abbildung an.

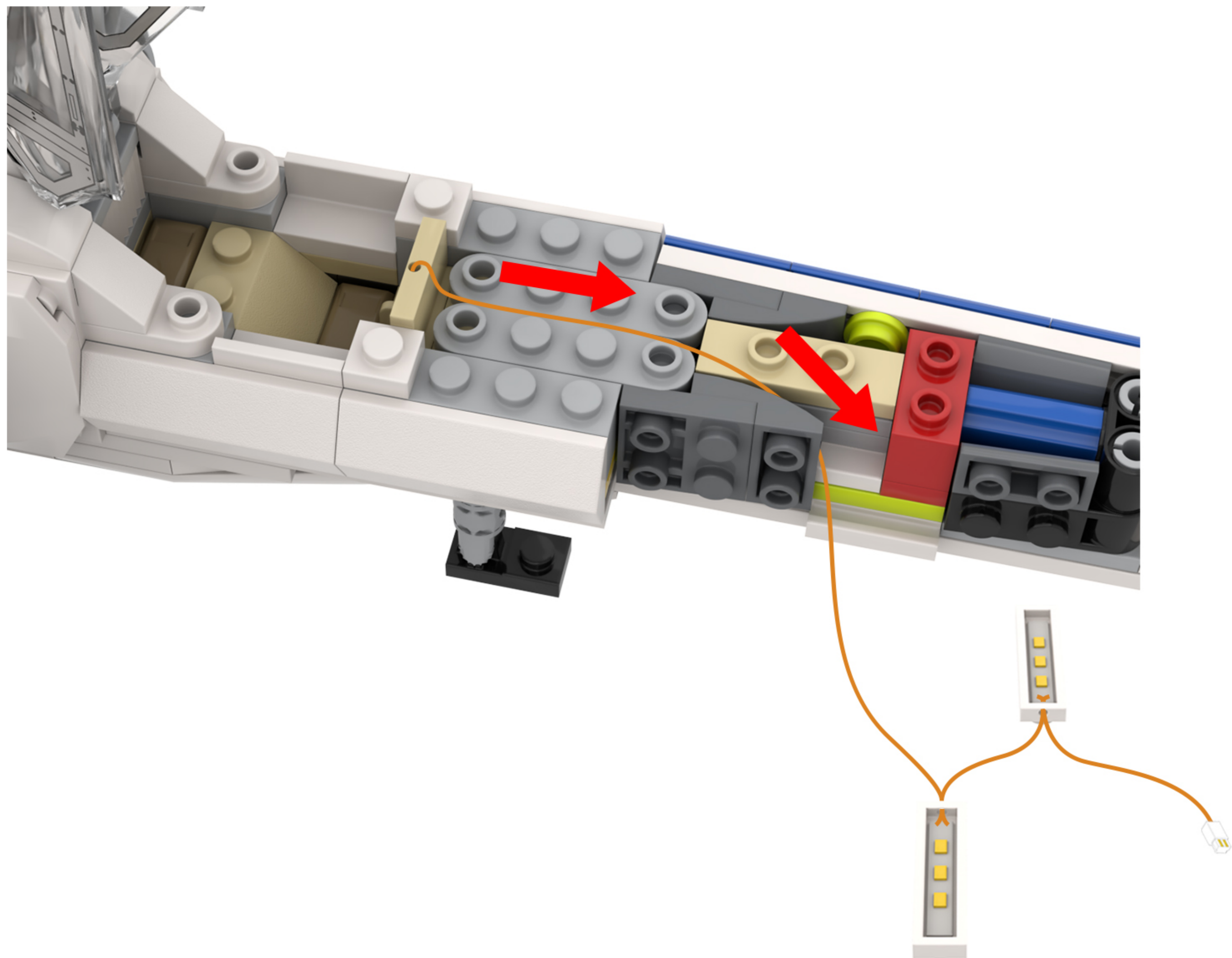

90

EN: Take out the disassembled building blocks, reassemble them, and secure the light cord.

DE: Nehmen Sie die zerlegten Bausteine heraus, setzen Sie sie wieder zusammen und befestigen Sie das Lichtkabel.

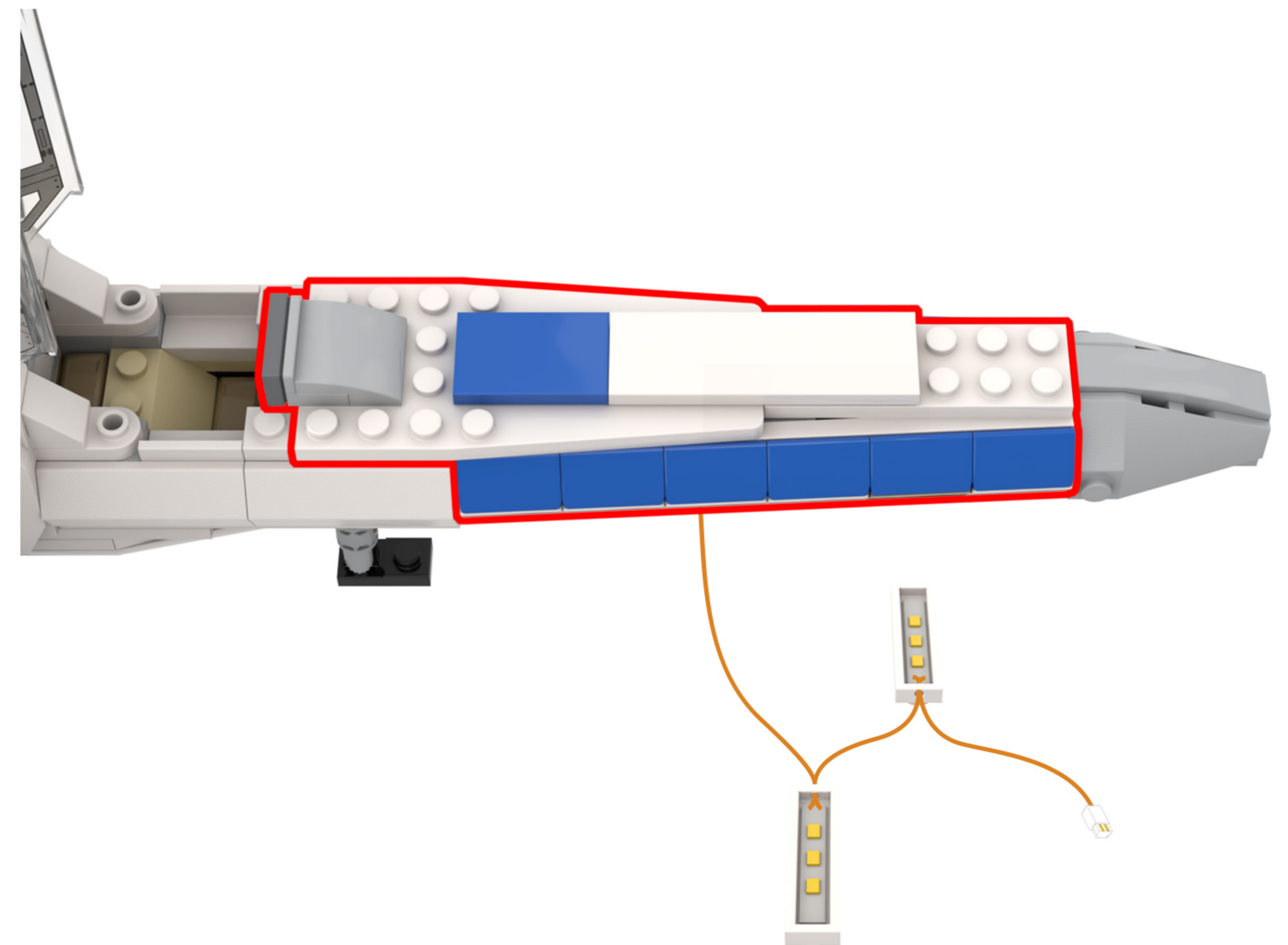
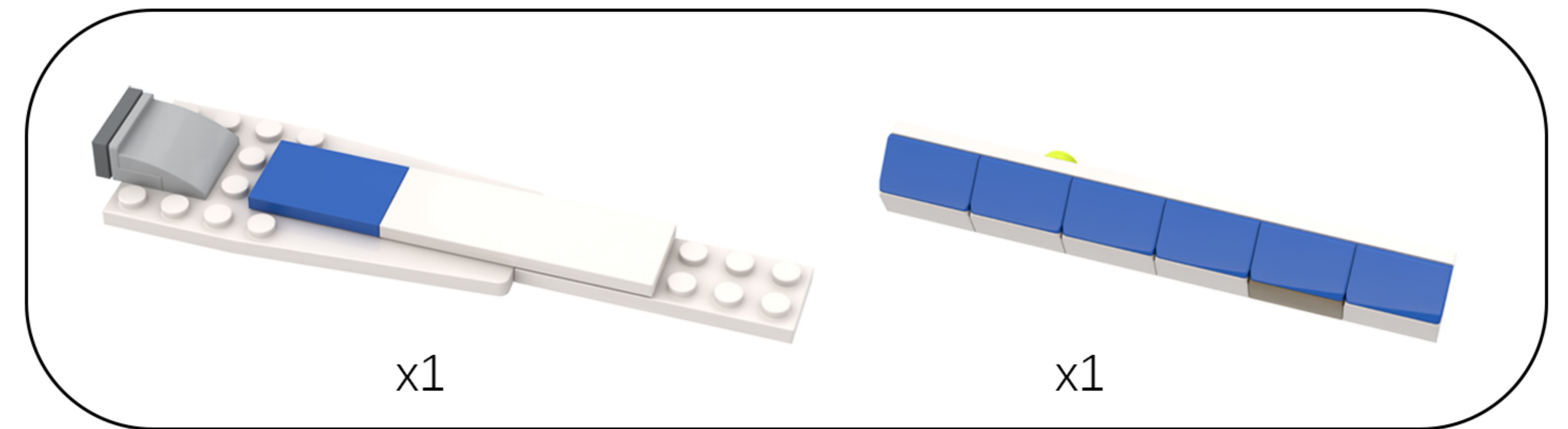

91

EN: Restore the building blocks.

DE: Stellen Sie die Bausteine wieder her.

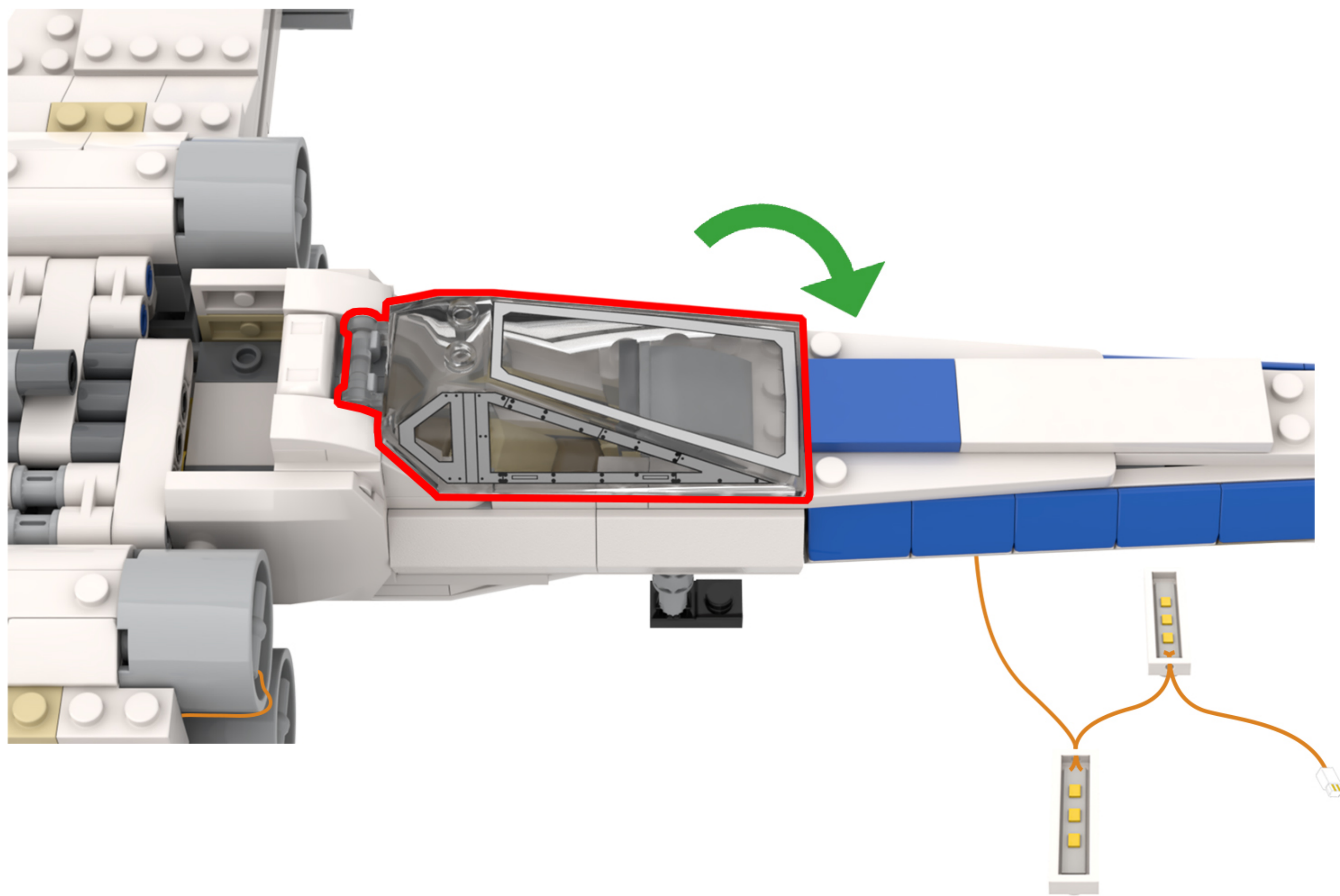

92

EN: Flip the model over so that the bottom is facing up.

DE: Drehen Sie das Modell um, sodass die Unterseite nach oben zeigt.

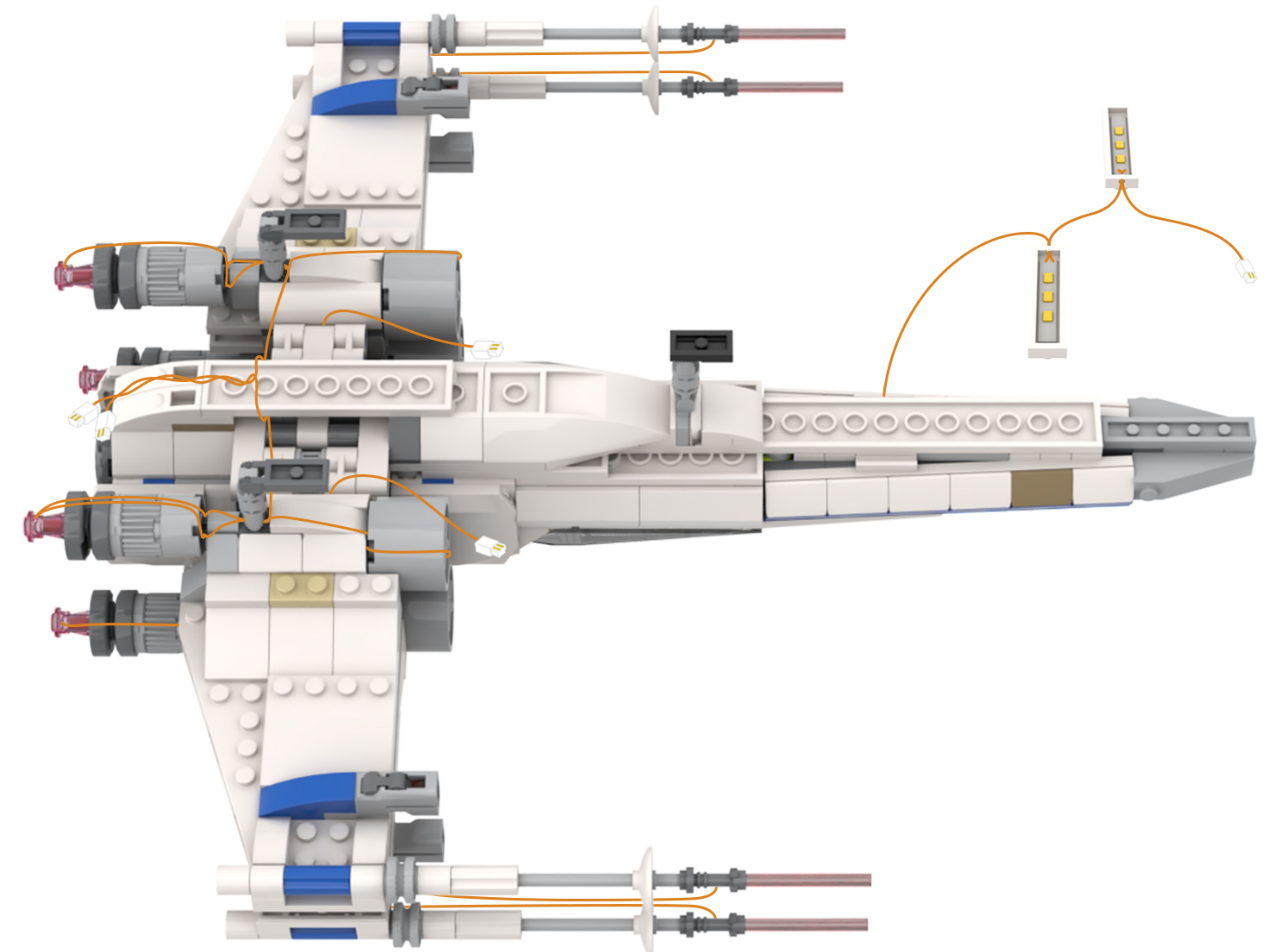

93

EN: Find the lights in the string of lights.

DE: Finde die Lichter in der Lichterkette.

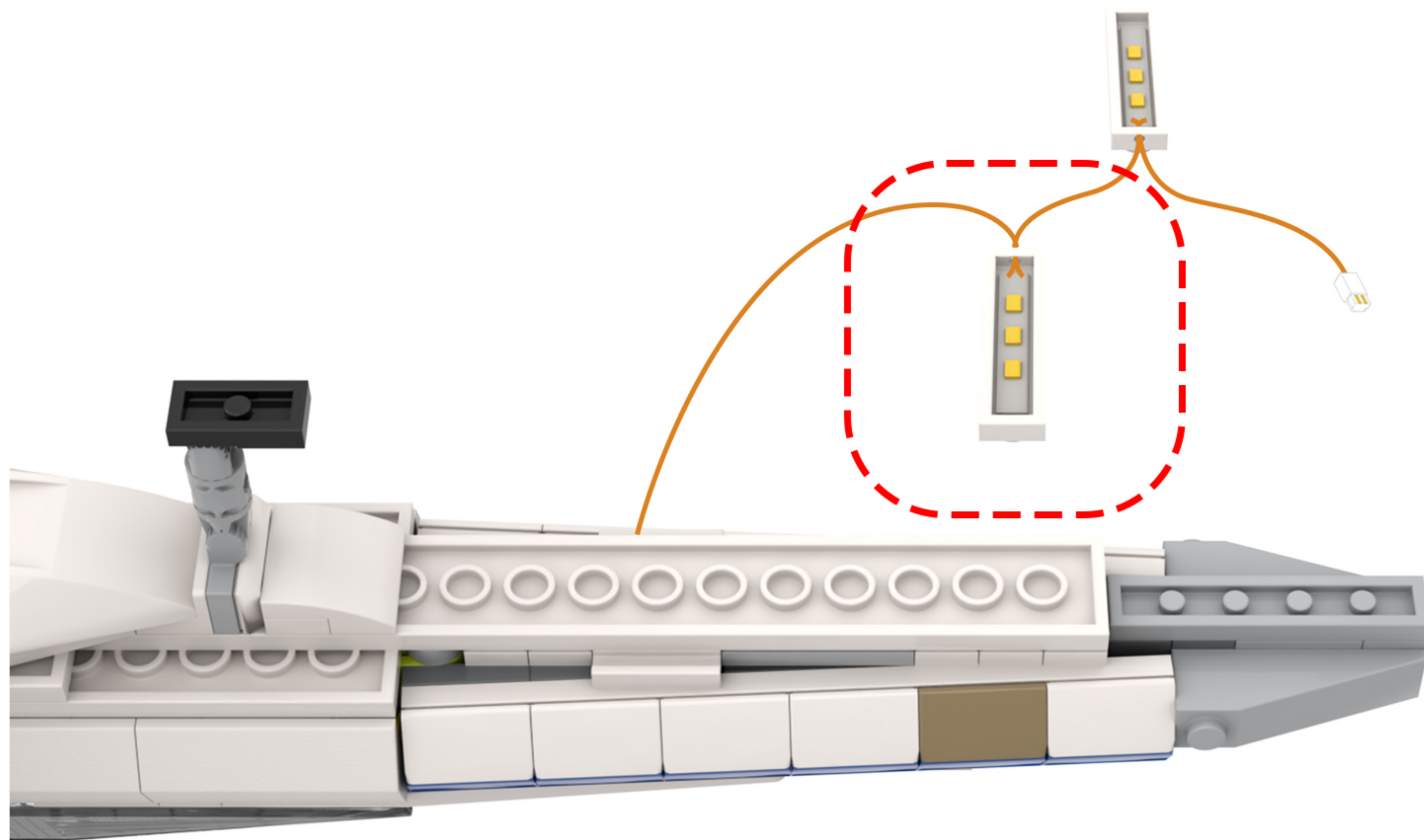

94

EN: Attach the lights from the string to the building blocks.

DE: Befestigen Sie die Lichter der Lichterkette an den Bausteinen.

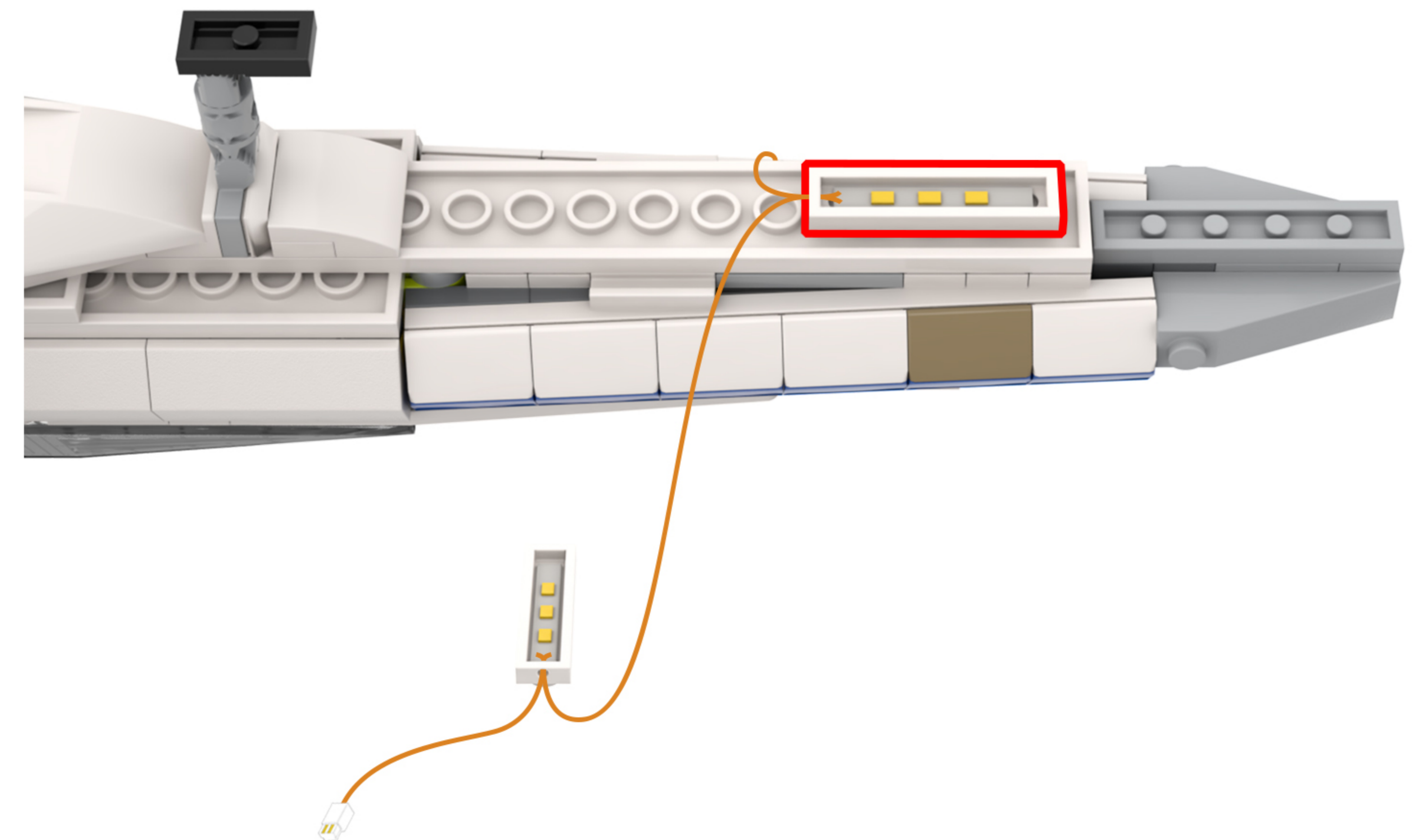

95

EN: Adjust your perspective.

DE: Ändern Sie Ihre Perspektive.

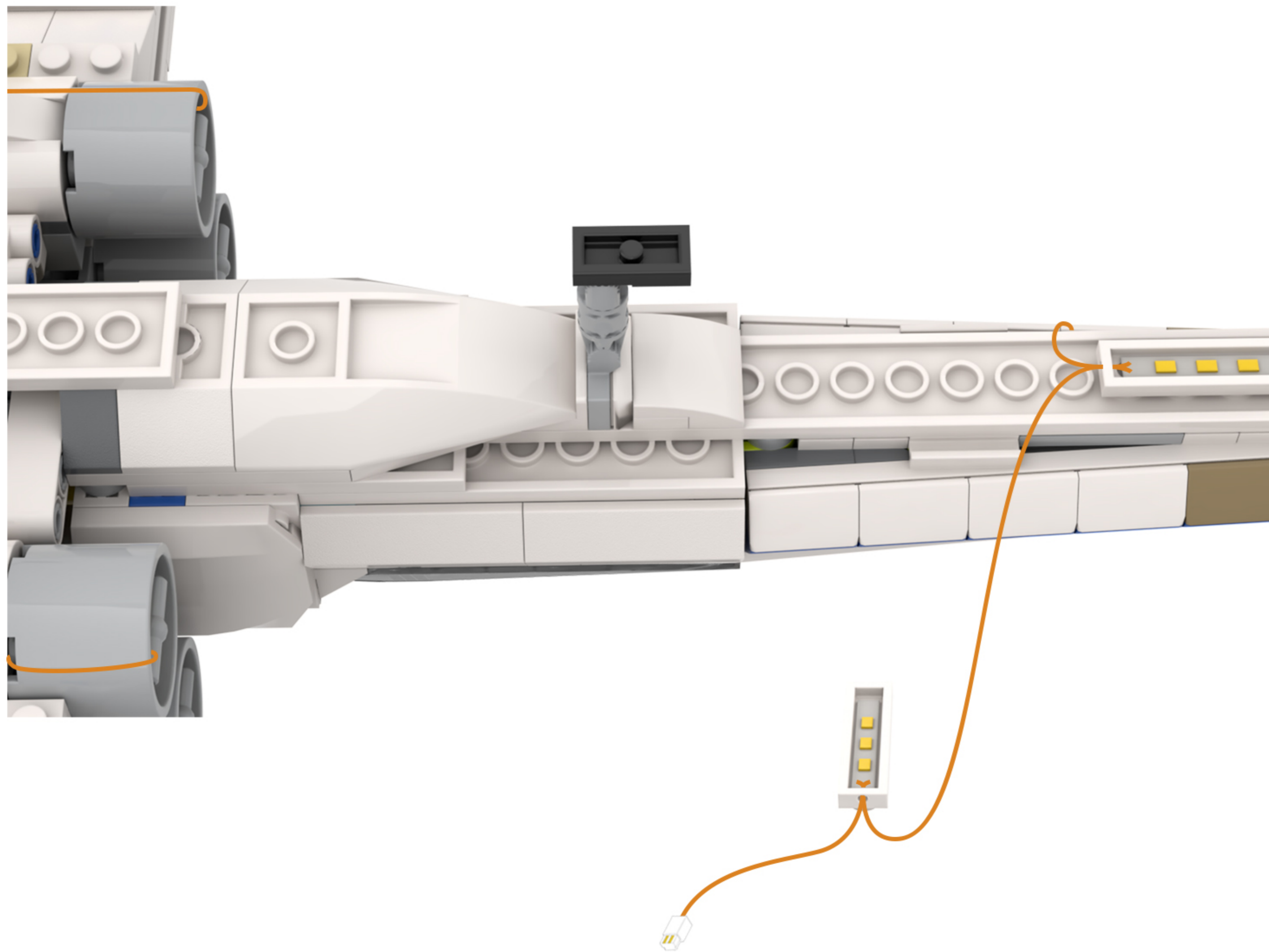

96

EN: Split as shown in the figure.

DE: Wie in der Abbildung gezeigt, teilen Sie es auf.

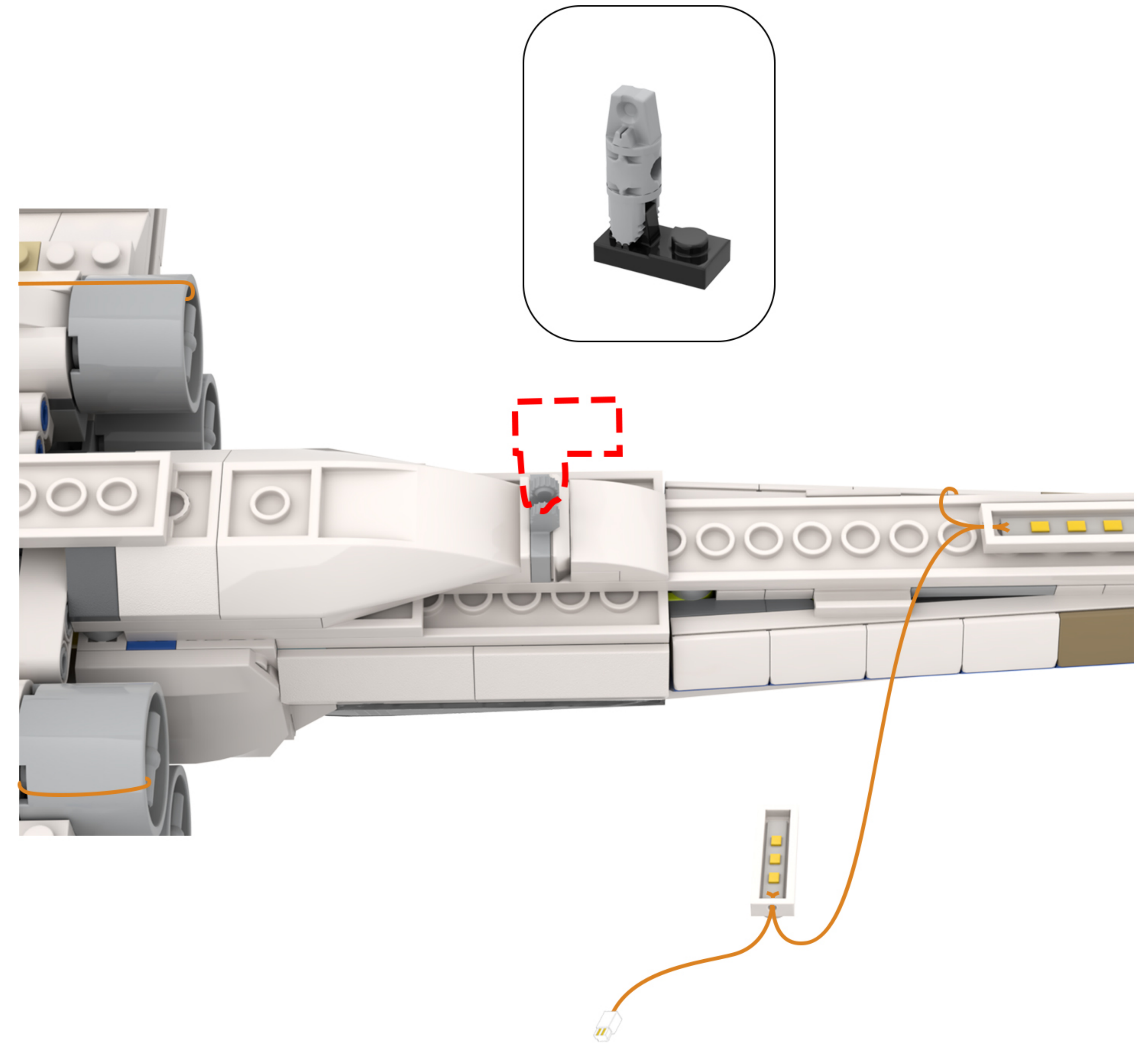

97

EN: Arrange the lighting lines according to the diagram.

DE: Ordnen Sie die Beleuchtungslinien gemäß der Abbildung an.

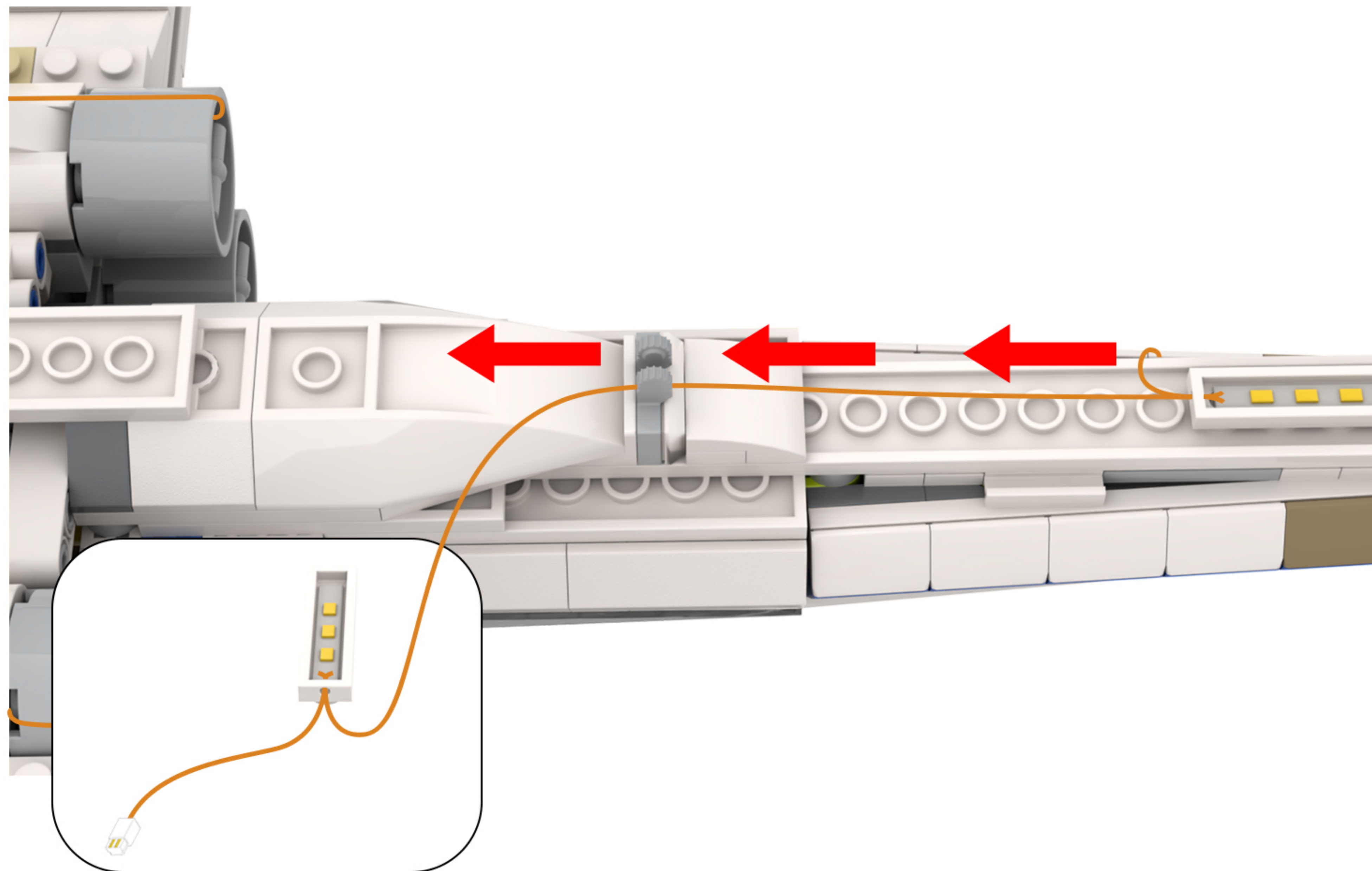

98

EN: Take out the disassembled building blocks, reassemble them, and secure the light cord.

DE: Nehmen Sie die zerlegten Bausteine heraus, setzen Sie sie wieder zusammen und befestigen Sie das Lichtkabel.

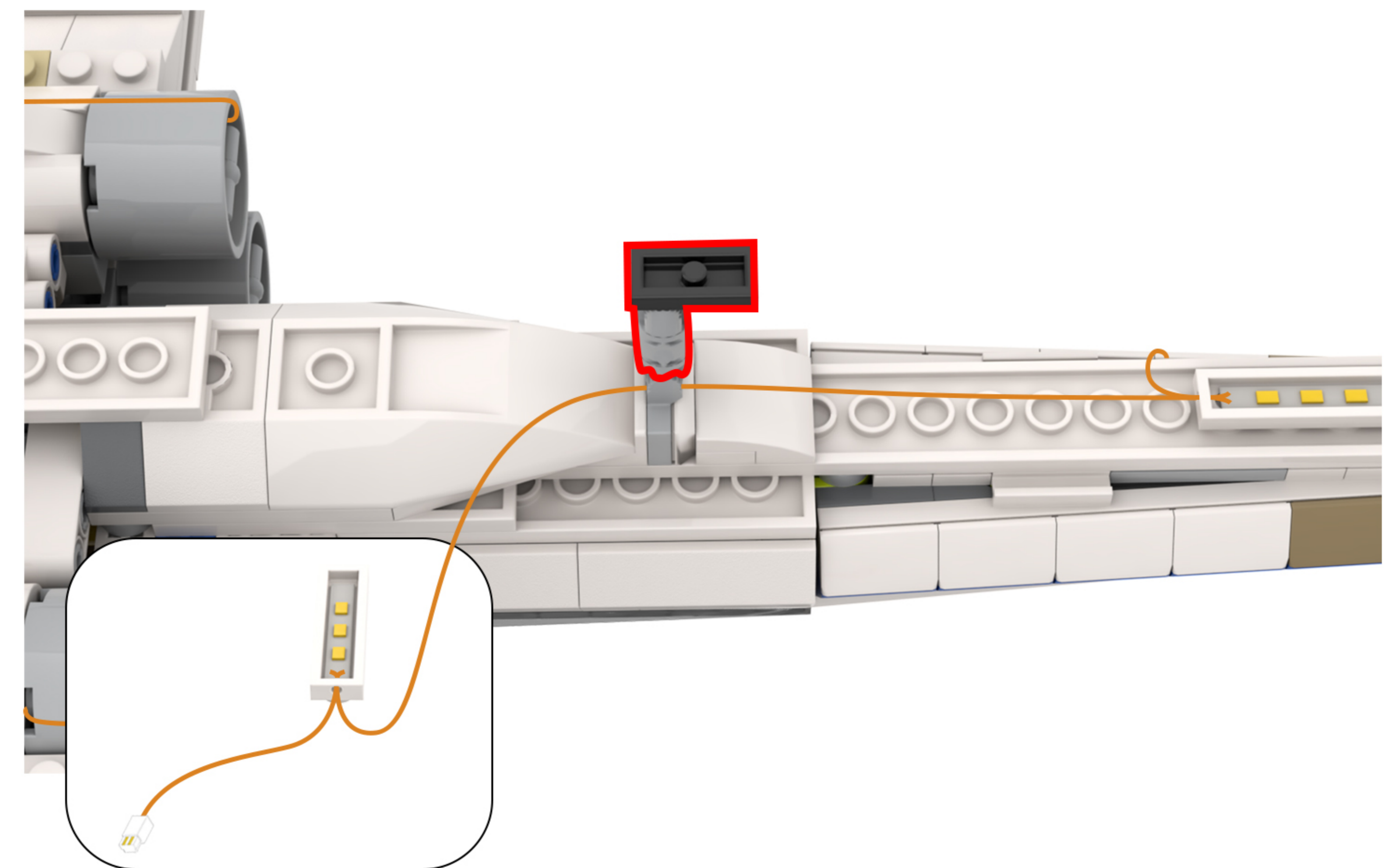
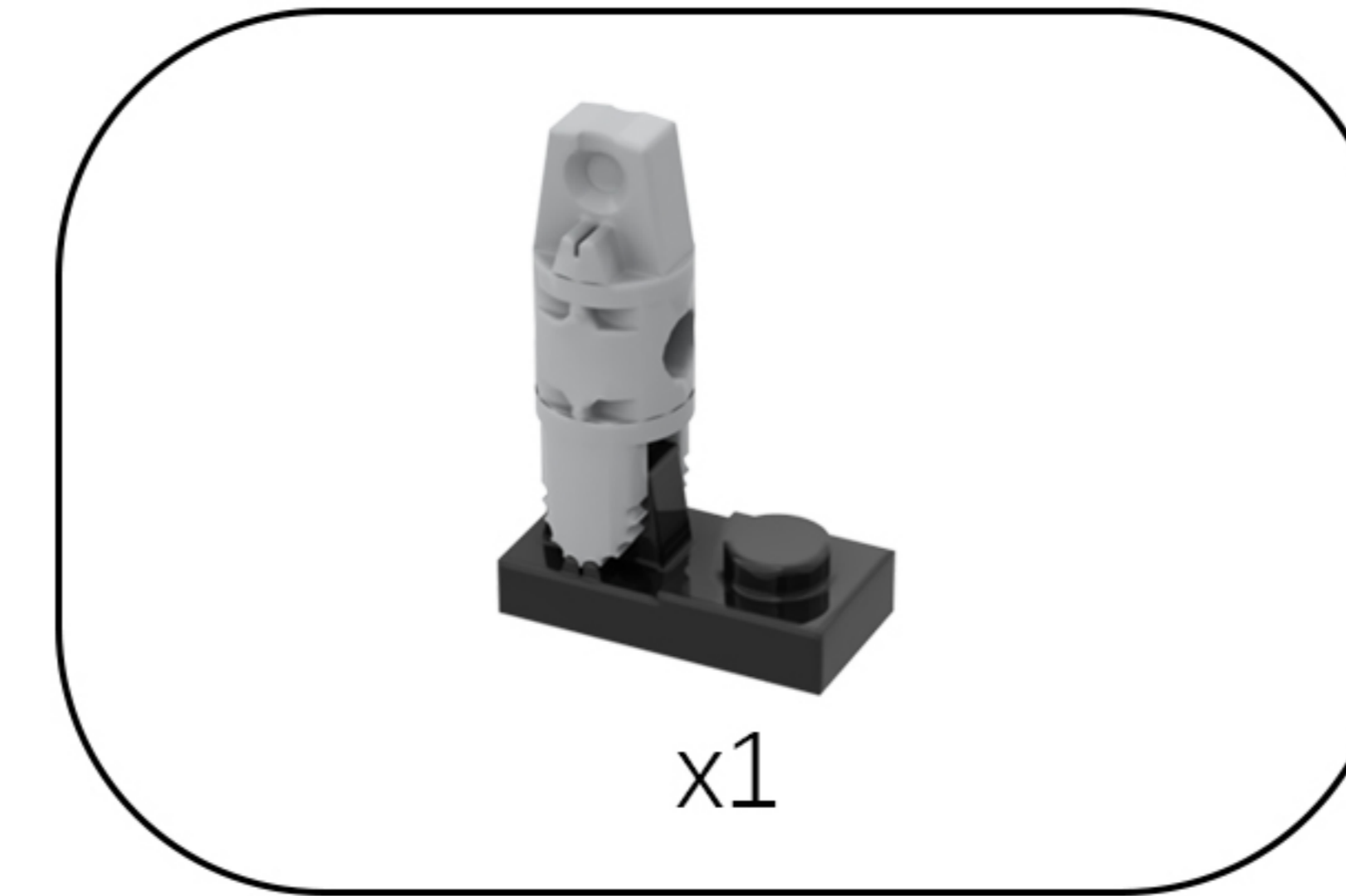

99

EN: Find the lights in the string of lights.

DE: Finde die Lichter in der Lichterkette.

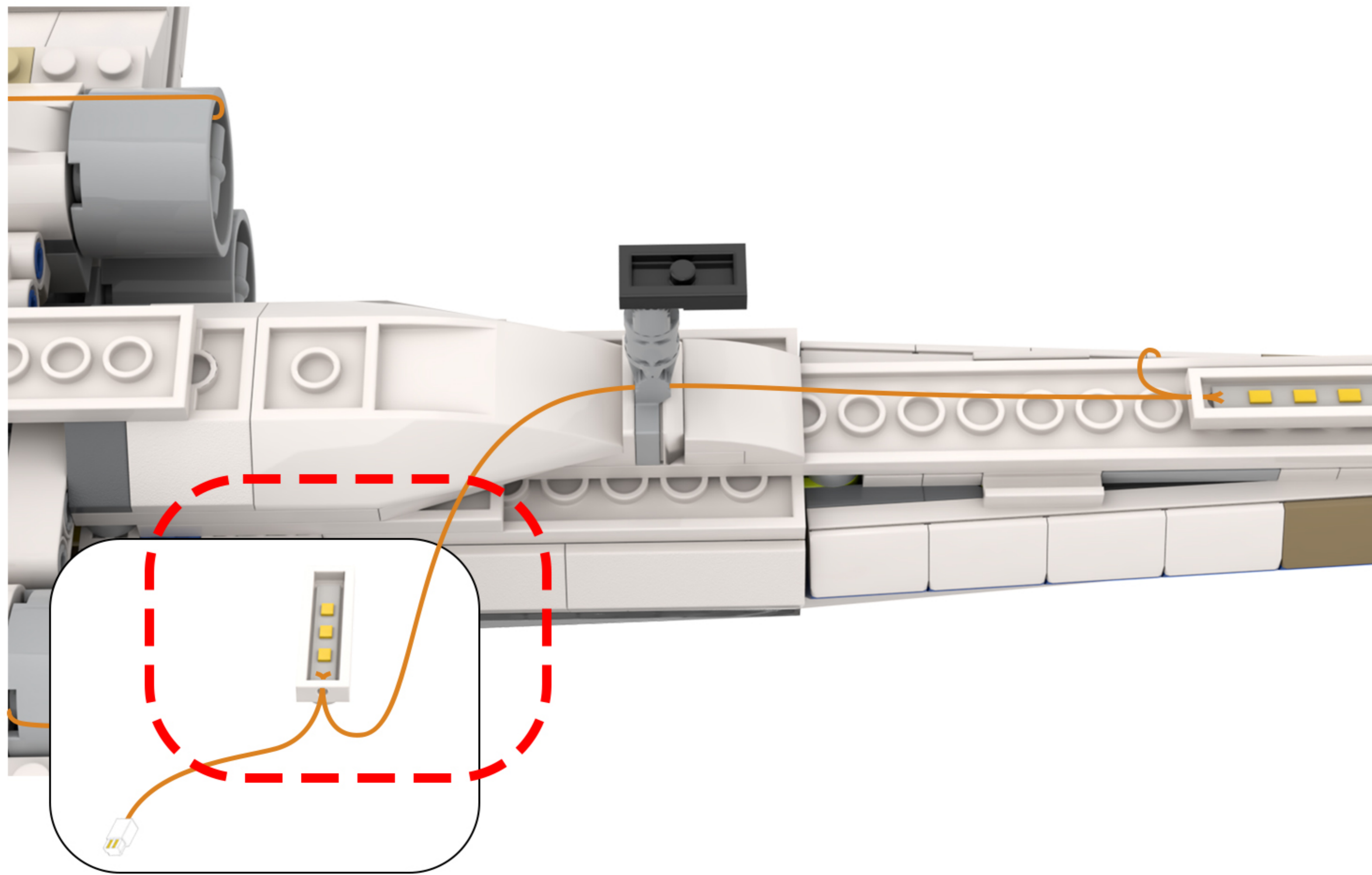

100

EN: Attach the lights from the string to the building blocks.

DE: Befestigen Sie die Lichter der Lichterkette an den Bausteinen.

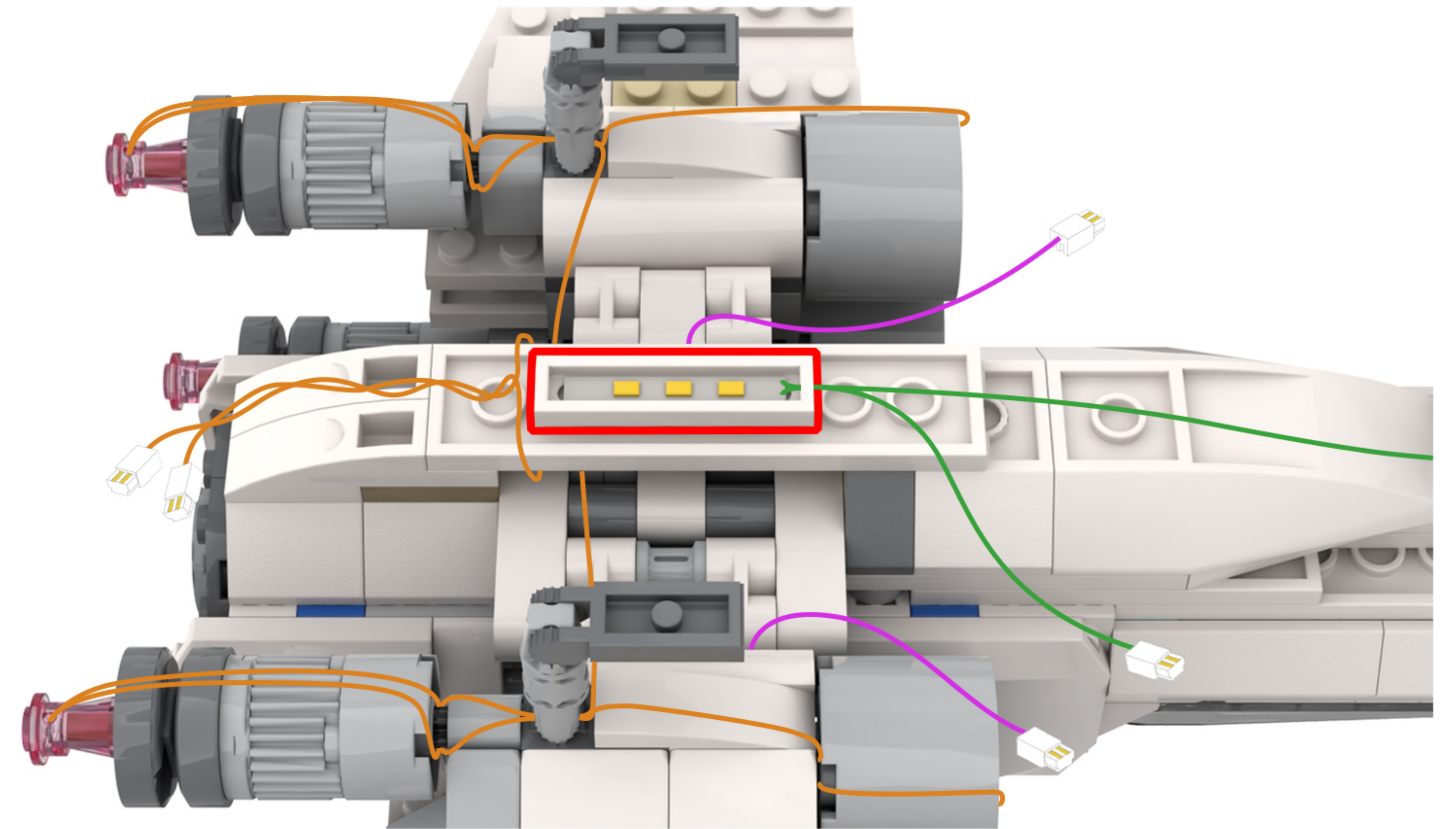

101

EN: Find the wires for the five light fixtures shown in the picture.

DE: Finde die Kabel für die fünf auf dem Bild gezeigten Leuchten.

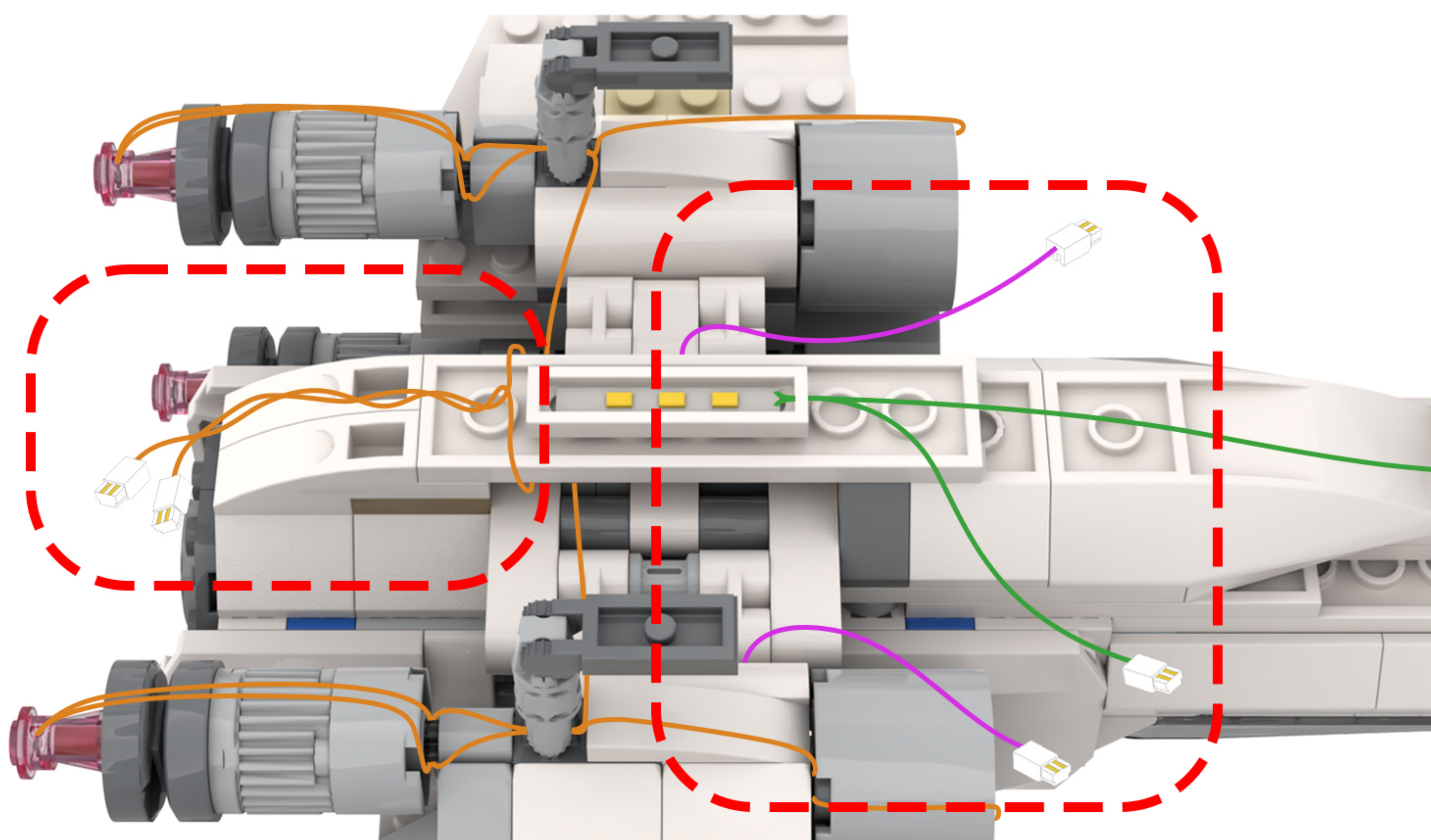

102

EN: Twist the wires from the five string lights together.

DE: Verdrehen Sie die Drähte der fünf Lichterketten miteinander.

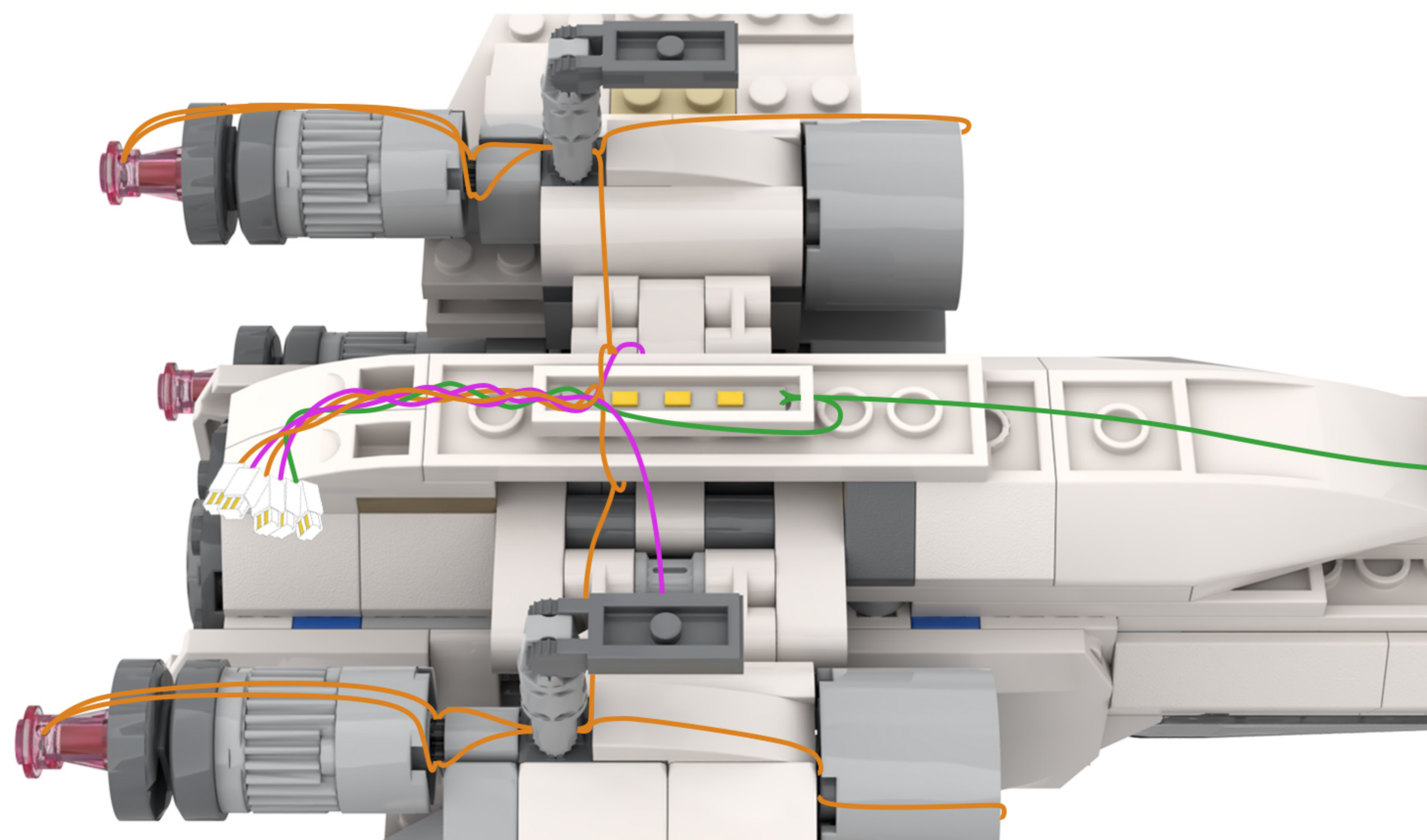

103

EN: Take the expansion board and the connecting cable out of Bag 4 and connect them together.

DE: Nehmen Sie die Erweiterungskarte und das Verbindungskabel aus Beutel 4 und verbinden Sie beide miteinander.

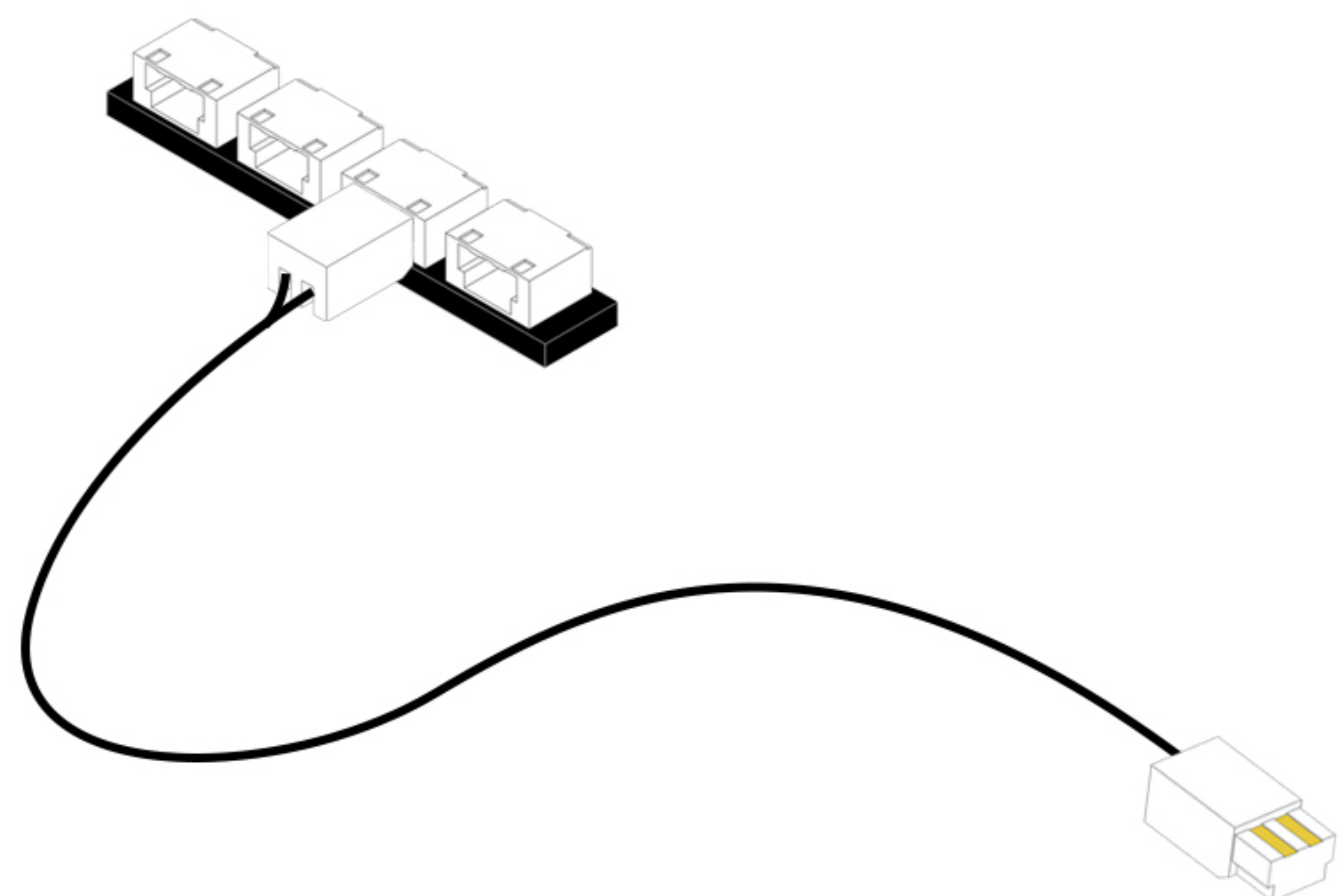
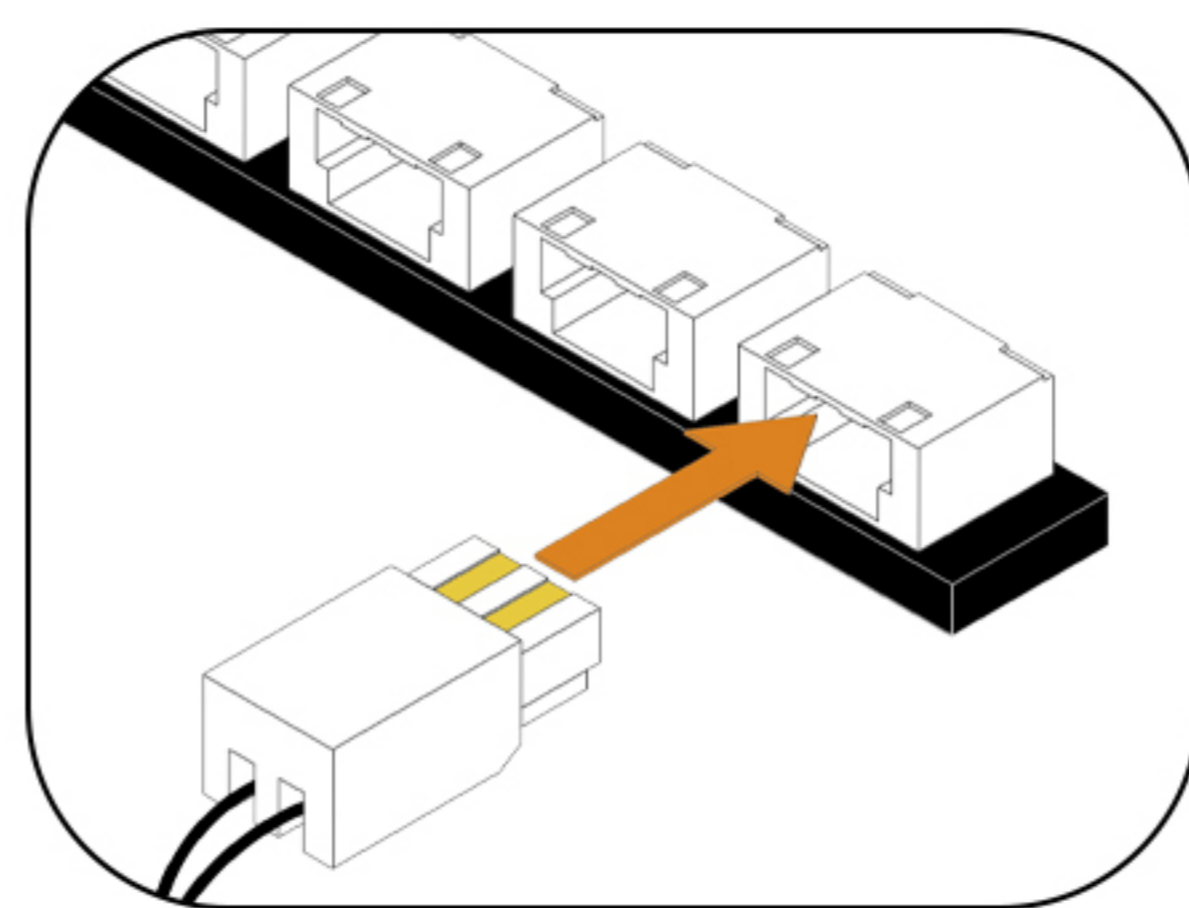
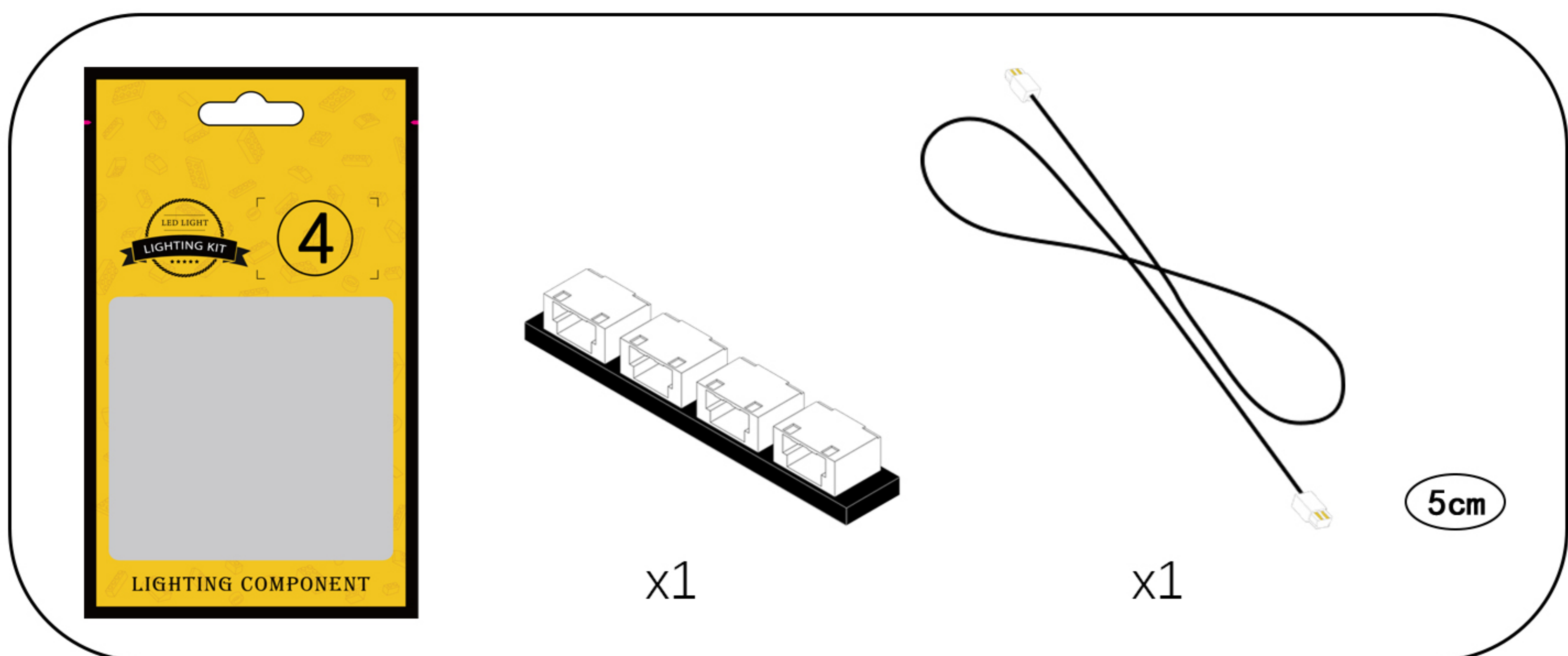

104

EN: Connect the two longer lamp wires to the expansion board one after the other.

DE: Schließen Sie die beiden längeren Lampenkabel nacheinander an die Erweiterungskarte an.

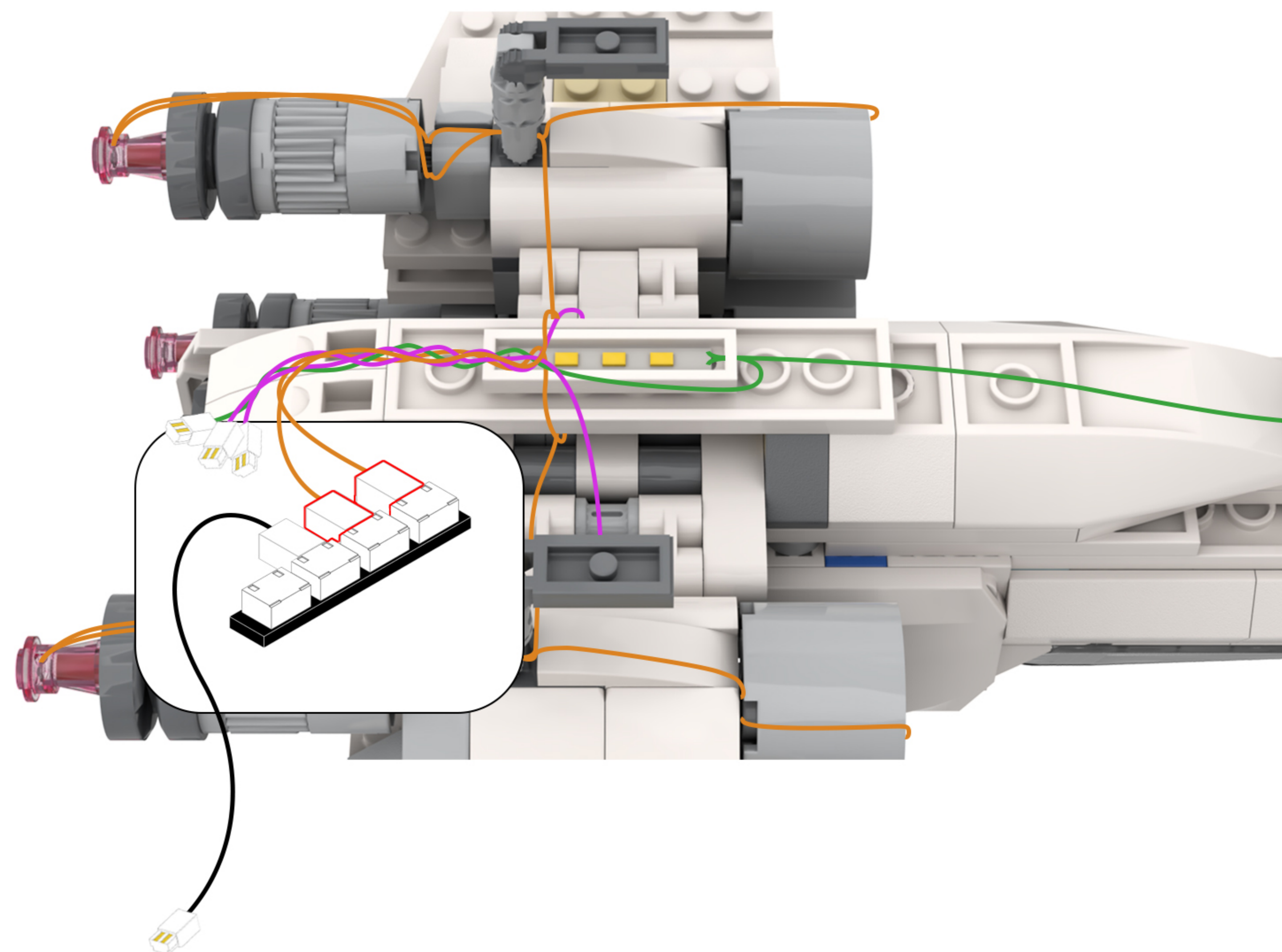
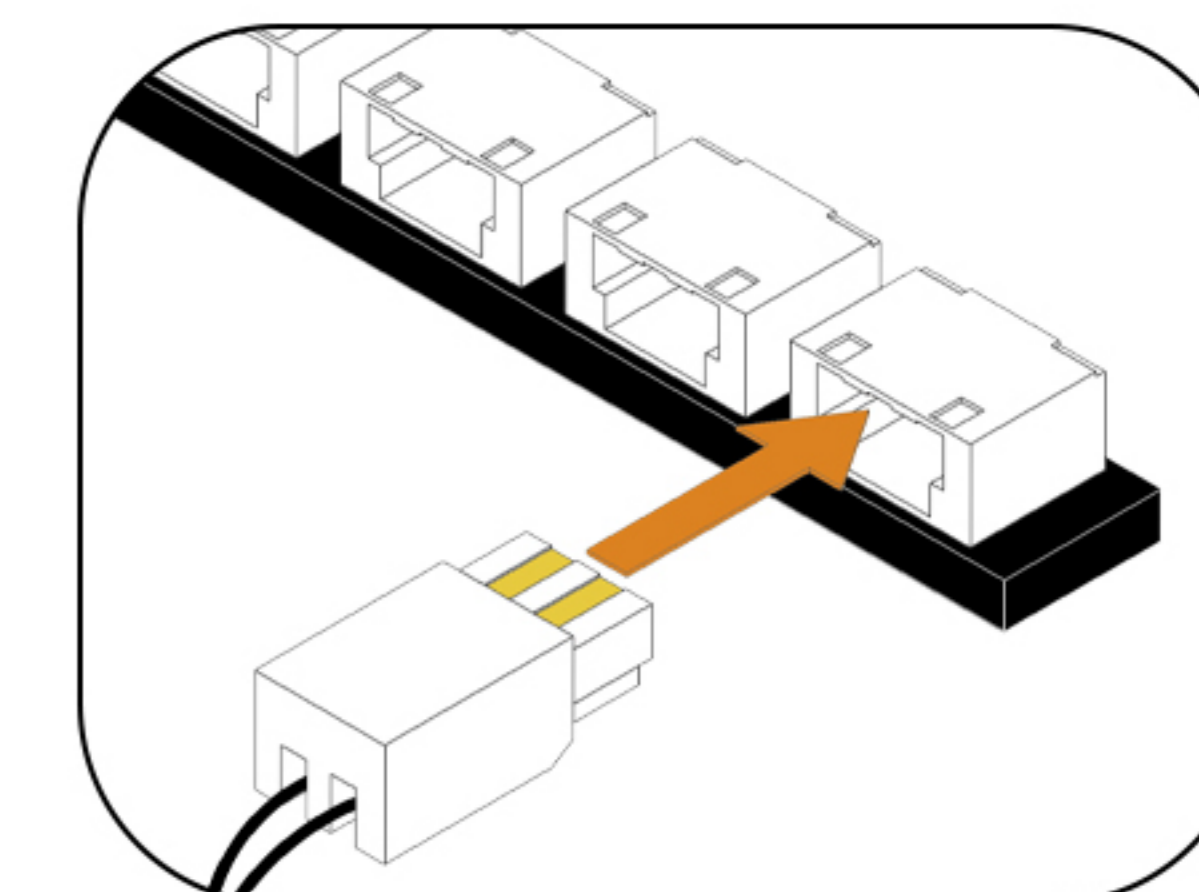

105

EN: Peel off the adhesive backing of the expansion board and attach it to the location shown in the illustration.

DE: Entfernen Sie die Schutzfolie von der Rückseite der Erweiterungsplatte und kleben Sie sie an die in der Abbildung gezeigte Stelle.

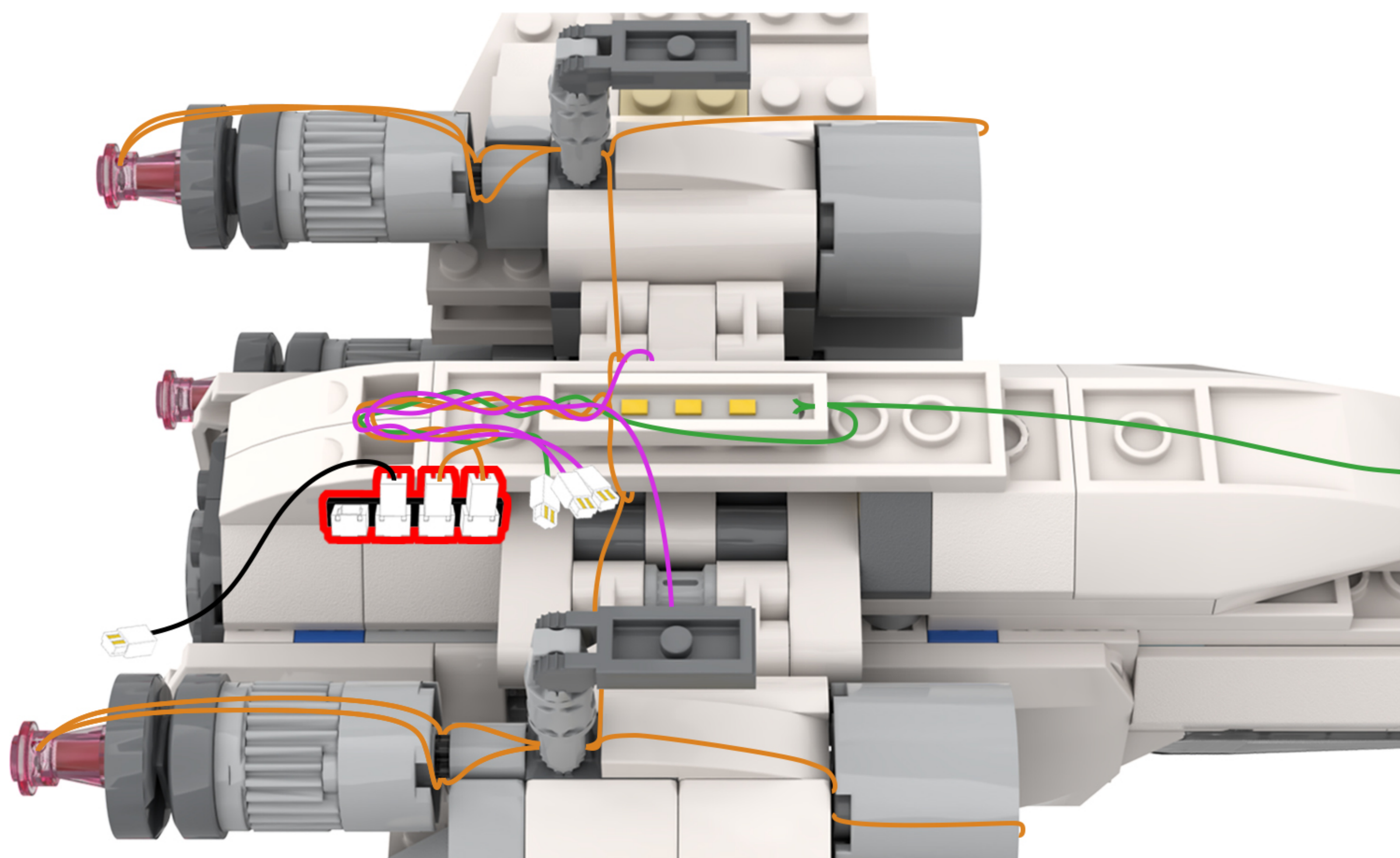
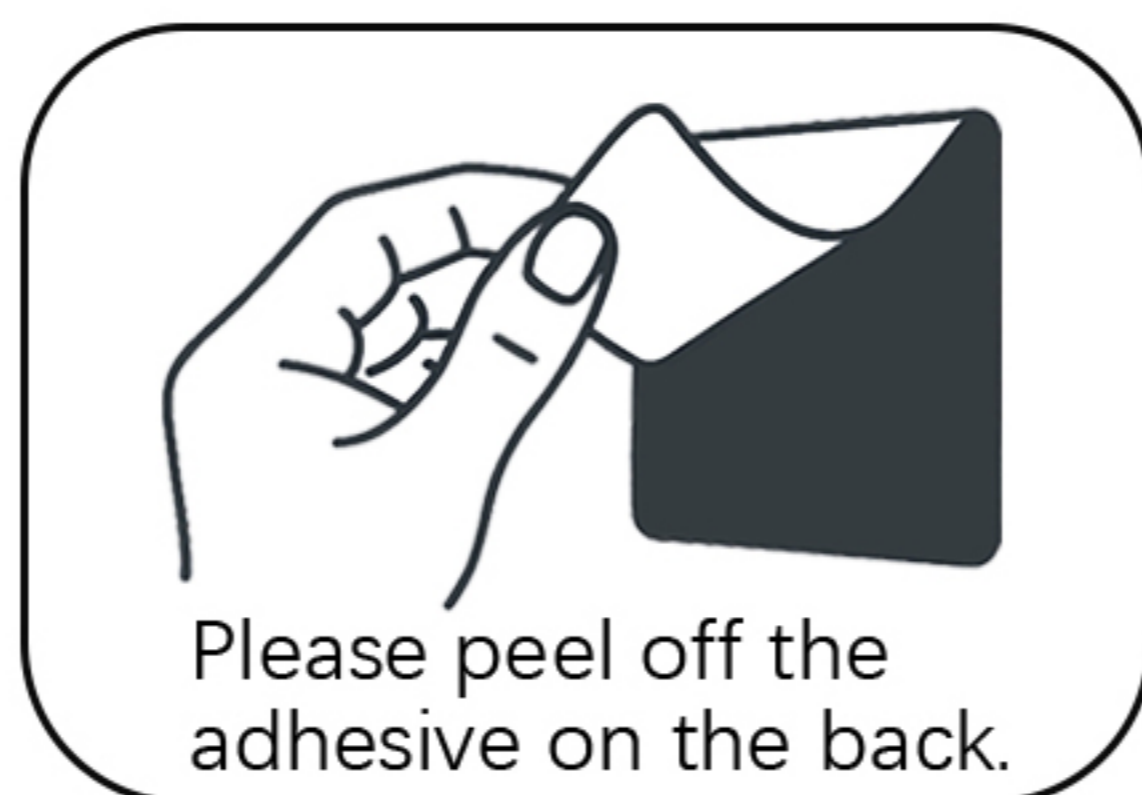

106

EN: Remove the remote control module and the remote control from bag A03801.

DE: Nehmen Sie das Fernbedienungsmodul und die Fernbedienung aus der Tasche A03801 heraus.

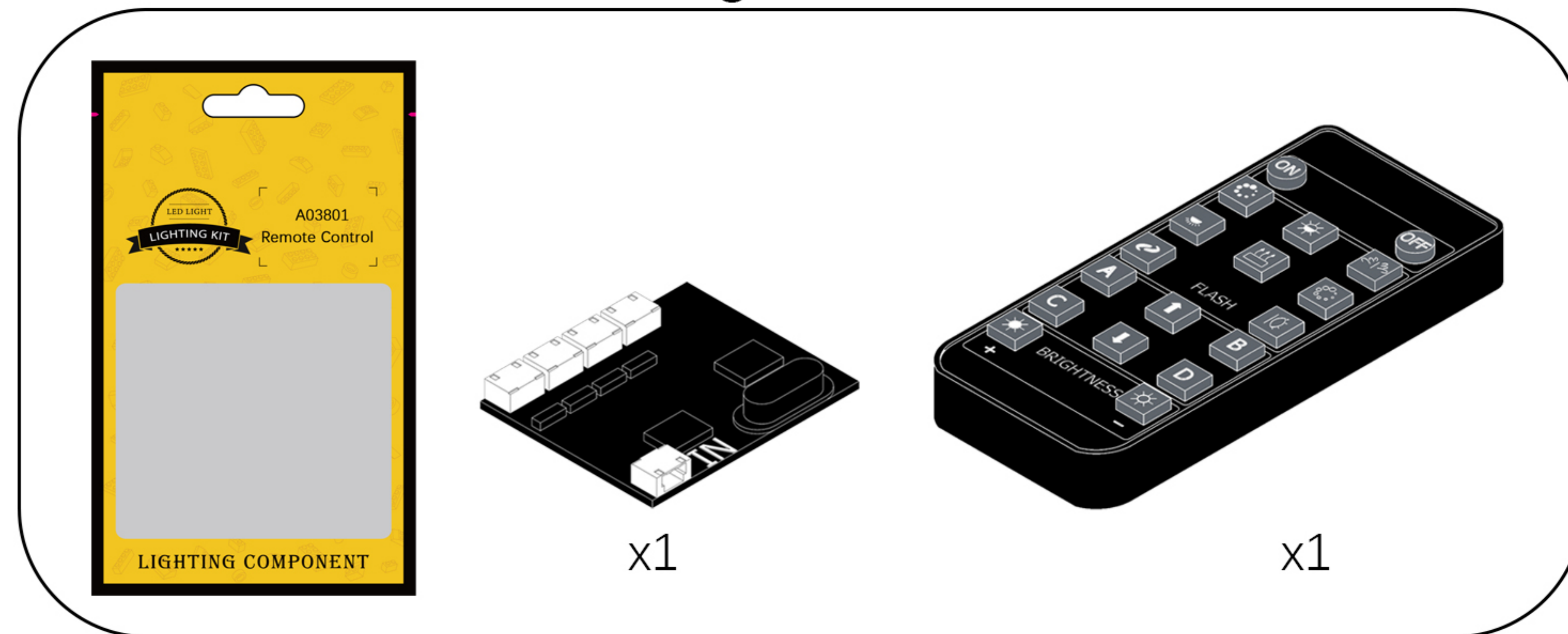

## Remote Control Function Introduce

**ON:** All lights turn on sequentially.  
**OFF:** All lights are off.

: A, B, C, D are turned on slowly in sequence.

: Breathing light mode.

: A and D the light is on and C and B flash alternately.

: A the light is on, B, C, D flow light effect I.

: A the light is on, B, C, D flow light effect II.

: Quickly open from A to D in turn.

: A, B, C, D flow light effect.

: A, B, C, D flash alternately.



**A:** Turn A on/off.

**B:** Turn B on/off.

**C:** Turn C on/off.

**D:** Turn D on/off.

**↑:** Increase frequency.

**↓:** Decrease frequency.

**⊕:** Brightness+: Increases brightness

**⊖:** Brightness-: Decreases brightness

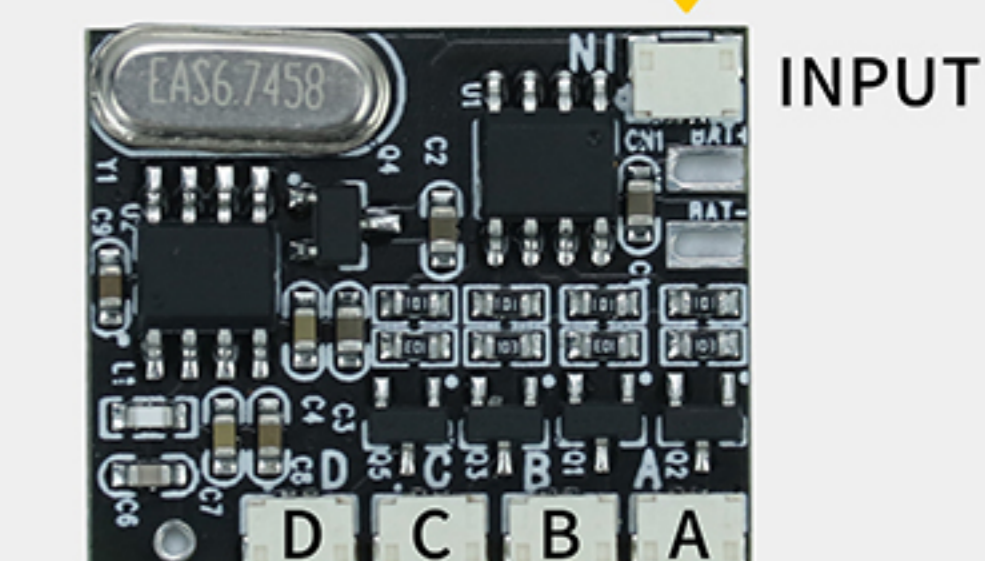

**107** EN: Remote Control Battery Replacement Instructions.

DE: Anleitung zum Batteriewechsel der Fernbedienung.

### Remote control safety lock and battery model description

Batteries are not included in the remote control, please go to the nearest store to buy CR2025 or CR2032 button batteries to install in the remote control.

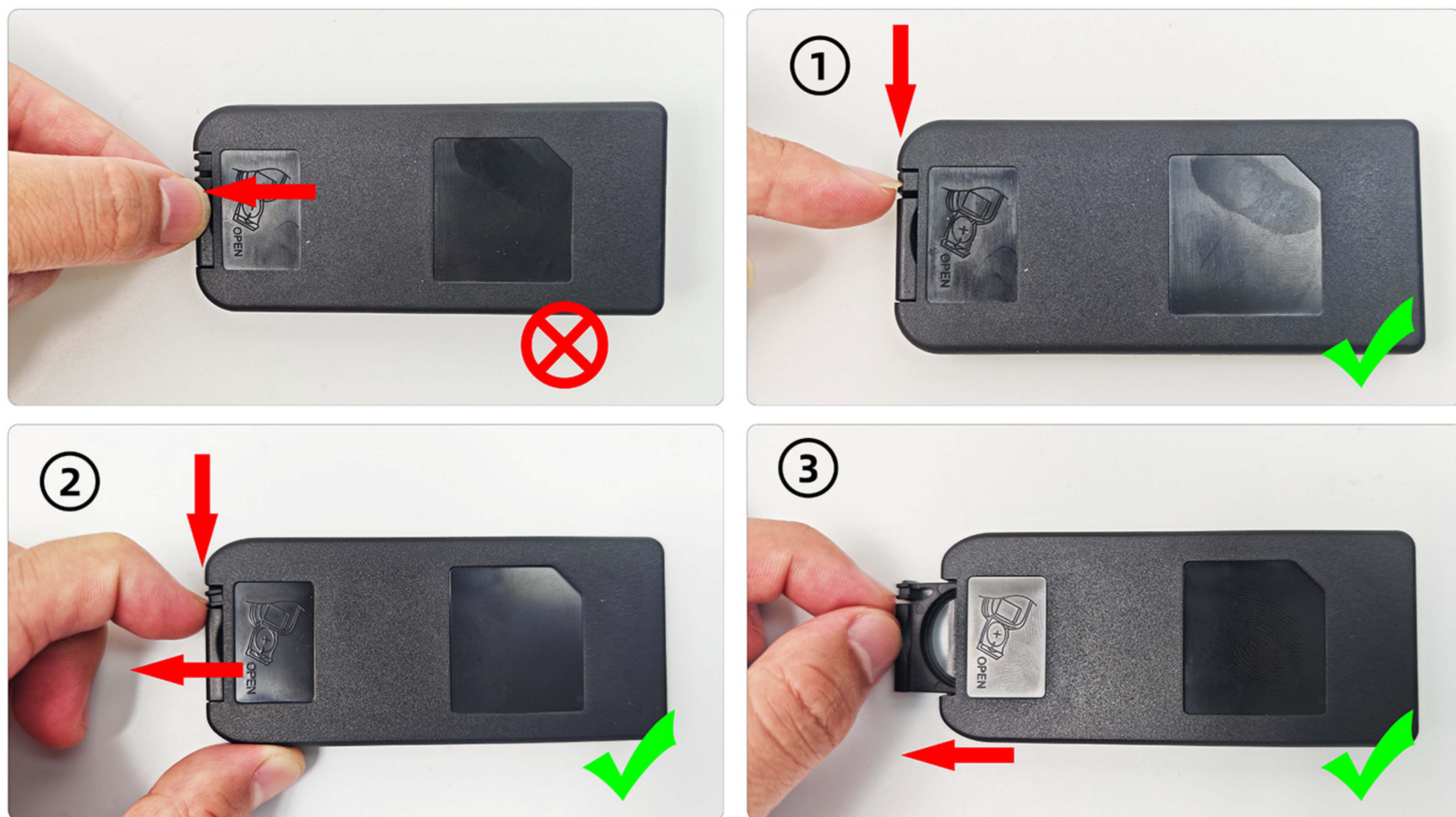

**108** EN: Connect the four light strands to the remote control module one by one.

DE: Schließen Sie die vier Lichterketten nacheinander an das Fernbedienungsmodul an.

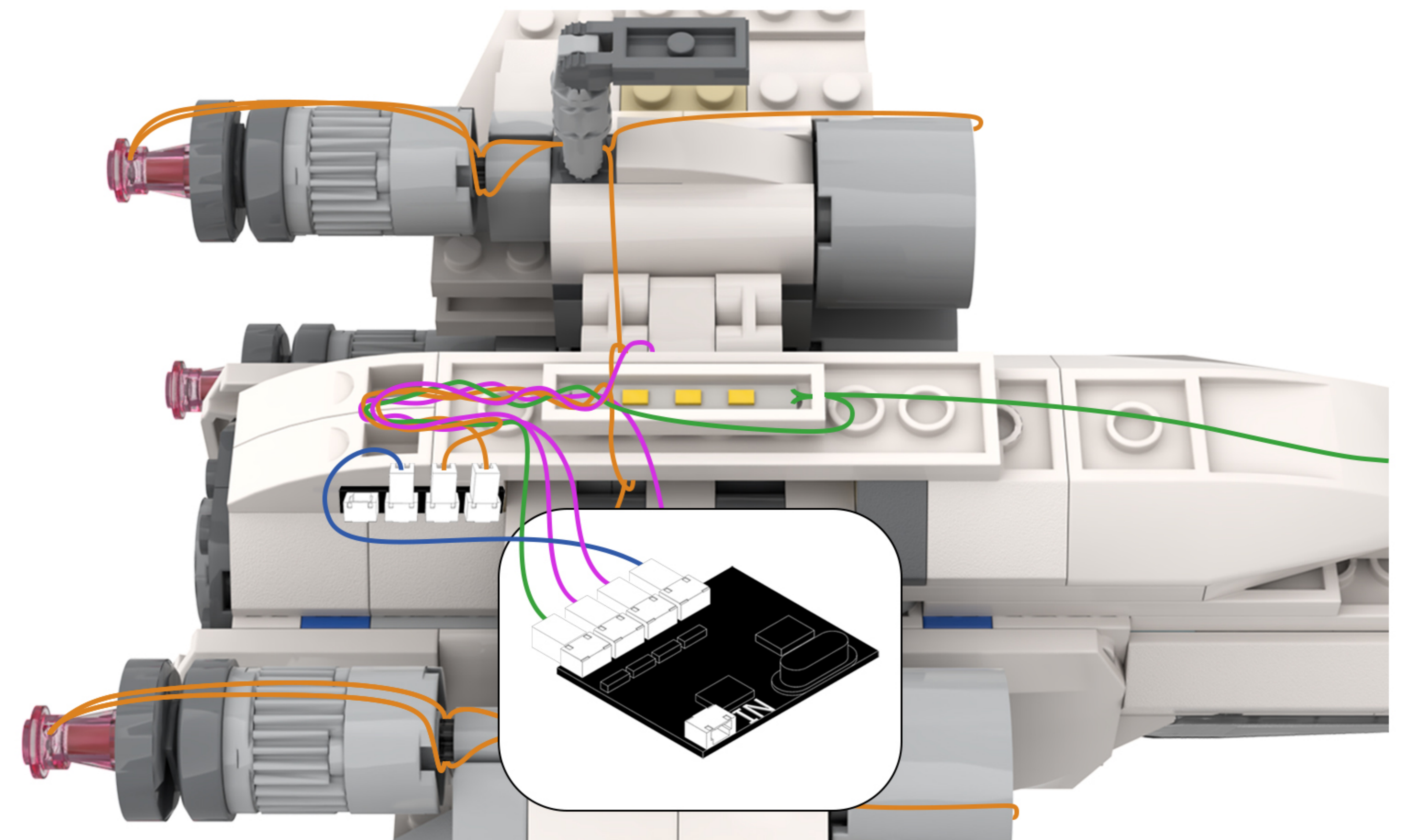
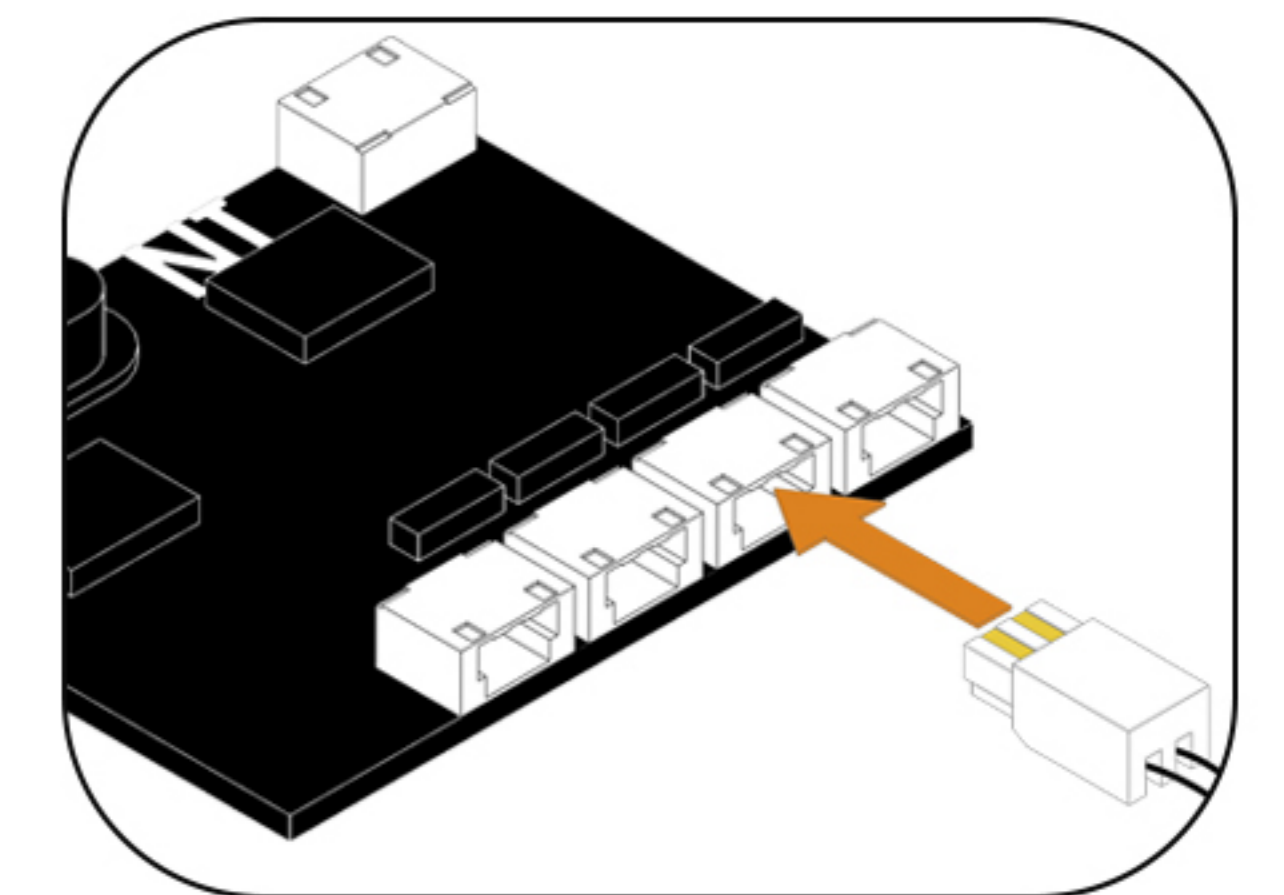

109

EN: Take the USB power cable out of the box and connect it to the remote control module.

DE: Nehmen Sie das USB-Stromkabel aus der Verpackung und schließen Sie es an das Fernbedienungsmodul an.

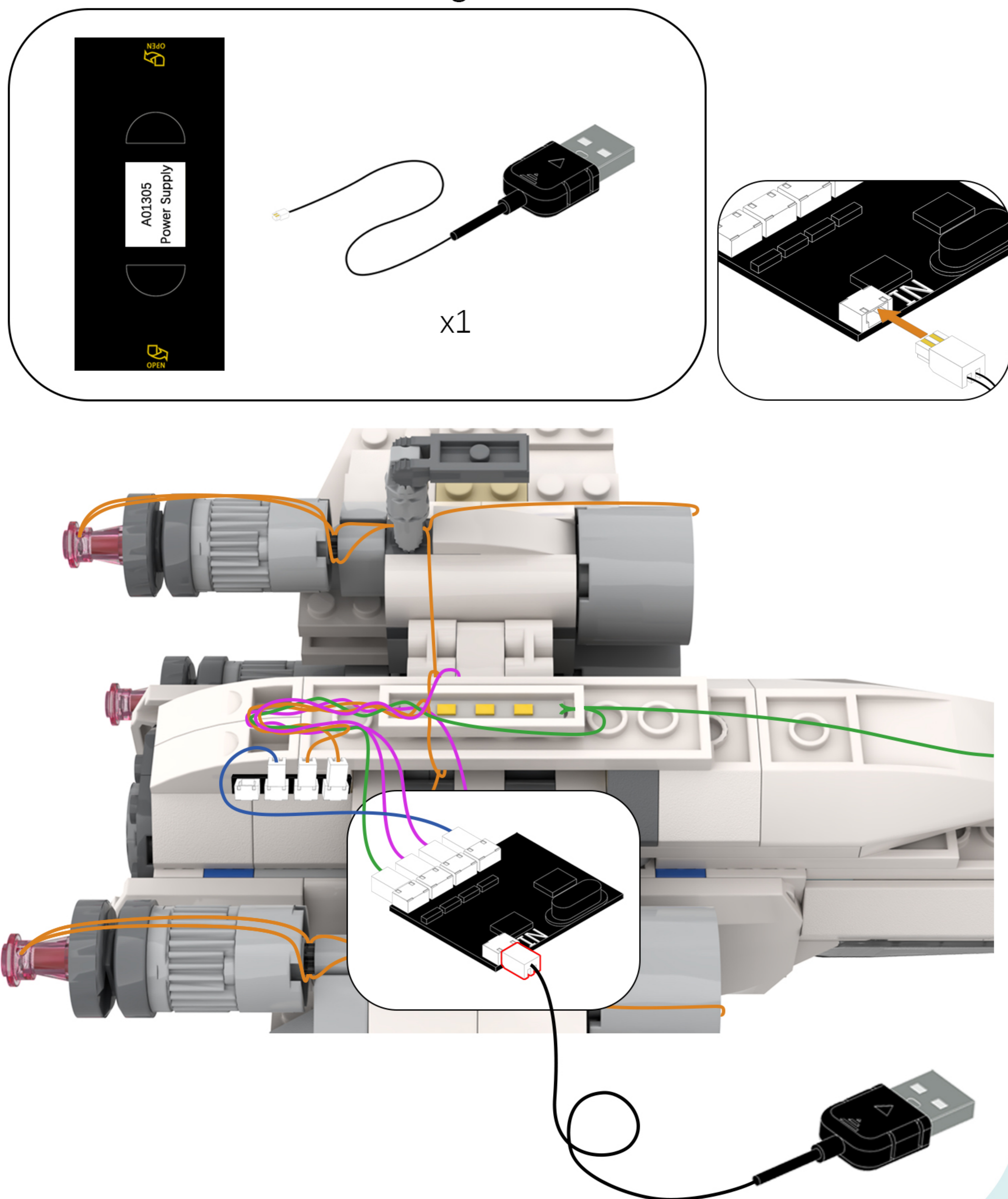

110

EN: Peel off the adhesive backing on the remote control module and attach it to the location shown in the diagram.

DE: Ziehen Sie die Klebefolie auf der Fernbedienung ab und befestigen Sie sie an der in der Abbildung gezeigten Stelle.

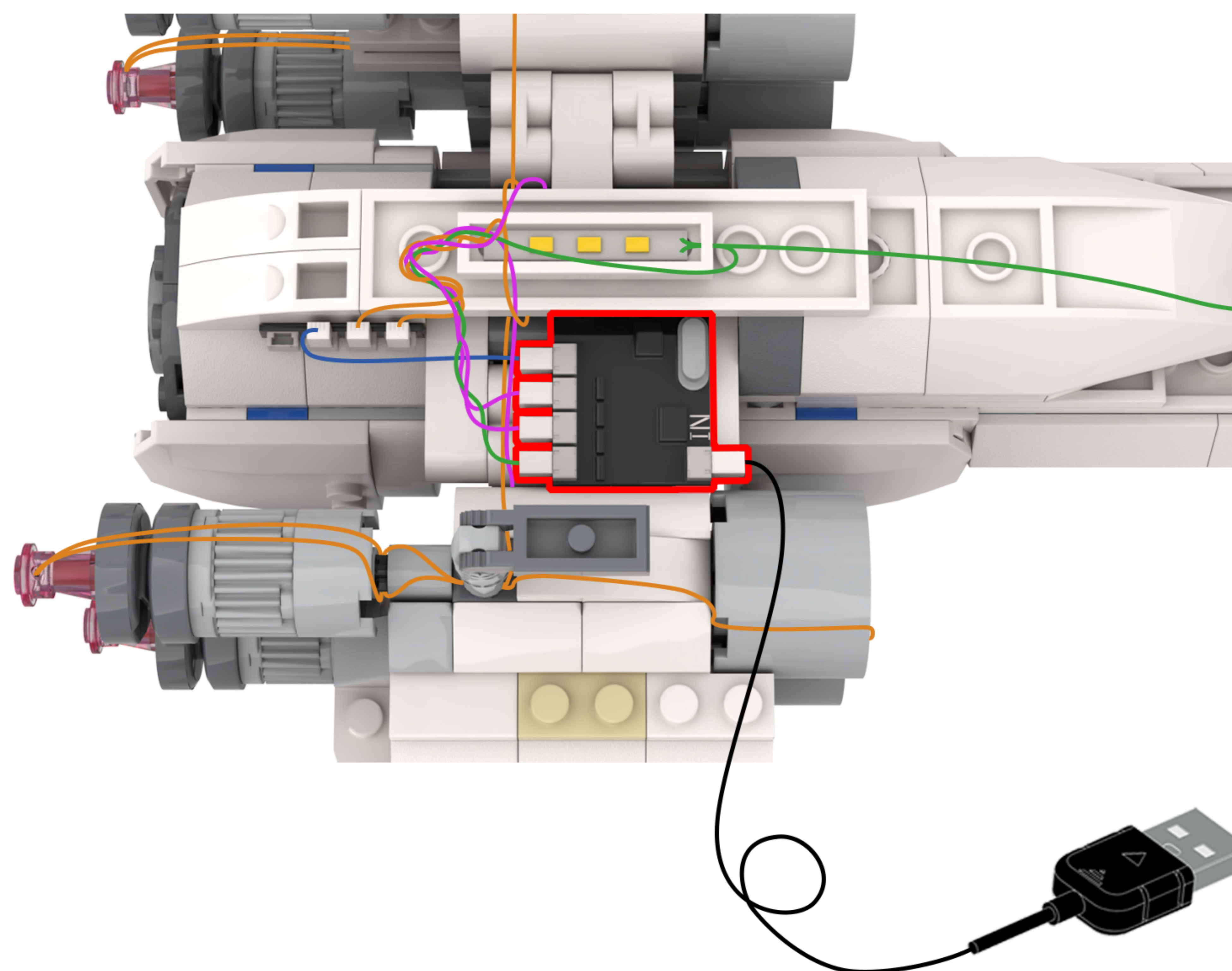

**111** EN: Flip the model back to its original orientation.  
DE: Drehen Sie das Modell wieder in seine ursprüngliche Ausrichtung zurück.

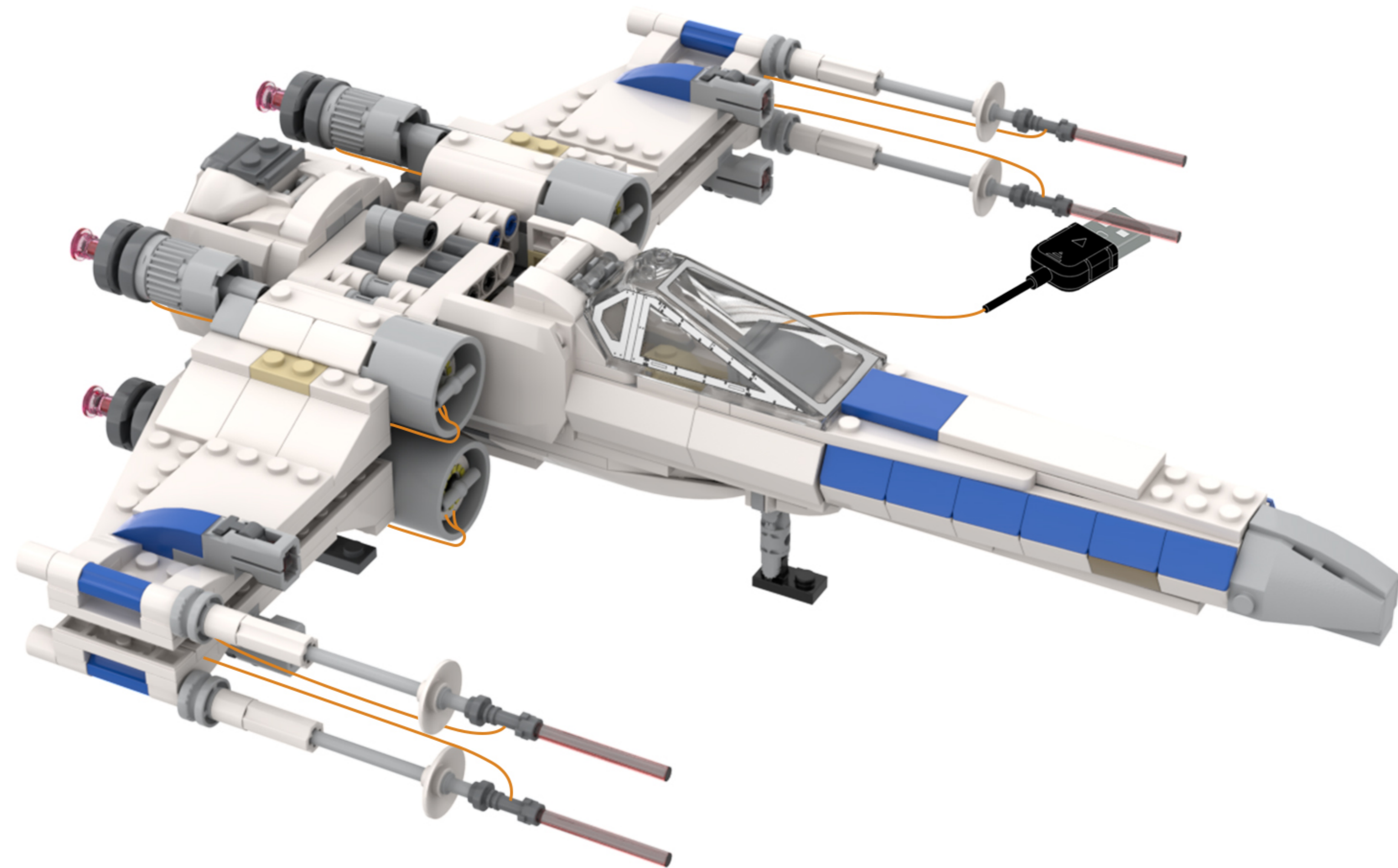
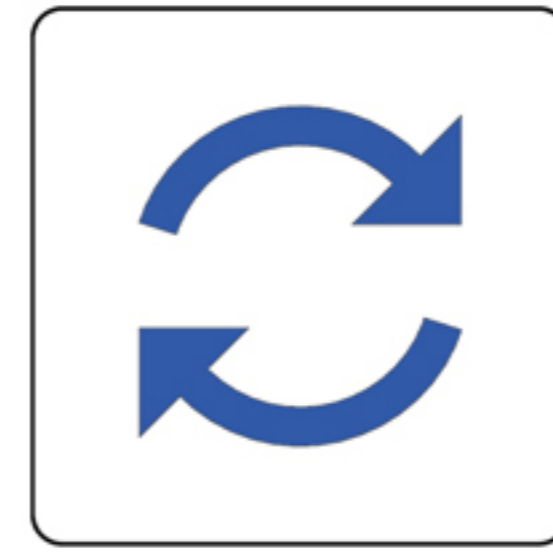

**112** EN: Once installed, connect the power supply and give it a try!  
DE: Die Installation ist abgeschlossen. Schließen Sie das Gerät an die Stromversorgung an und probieren Sie es aus!

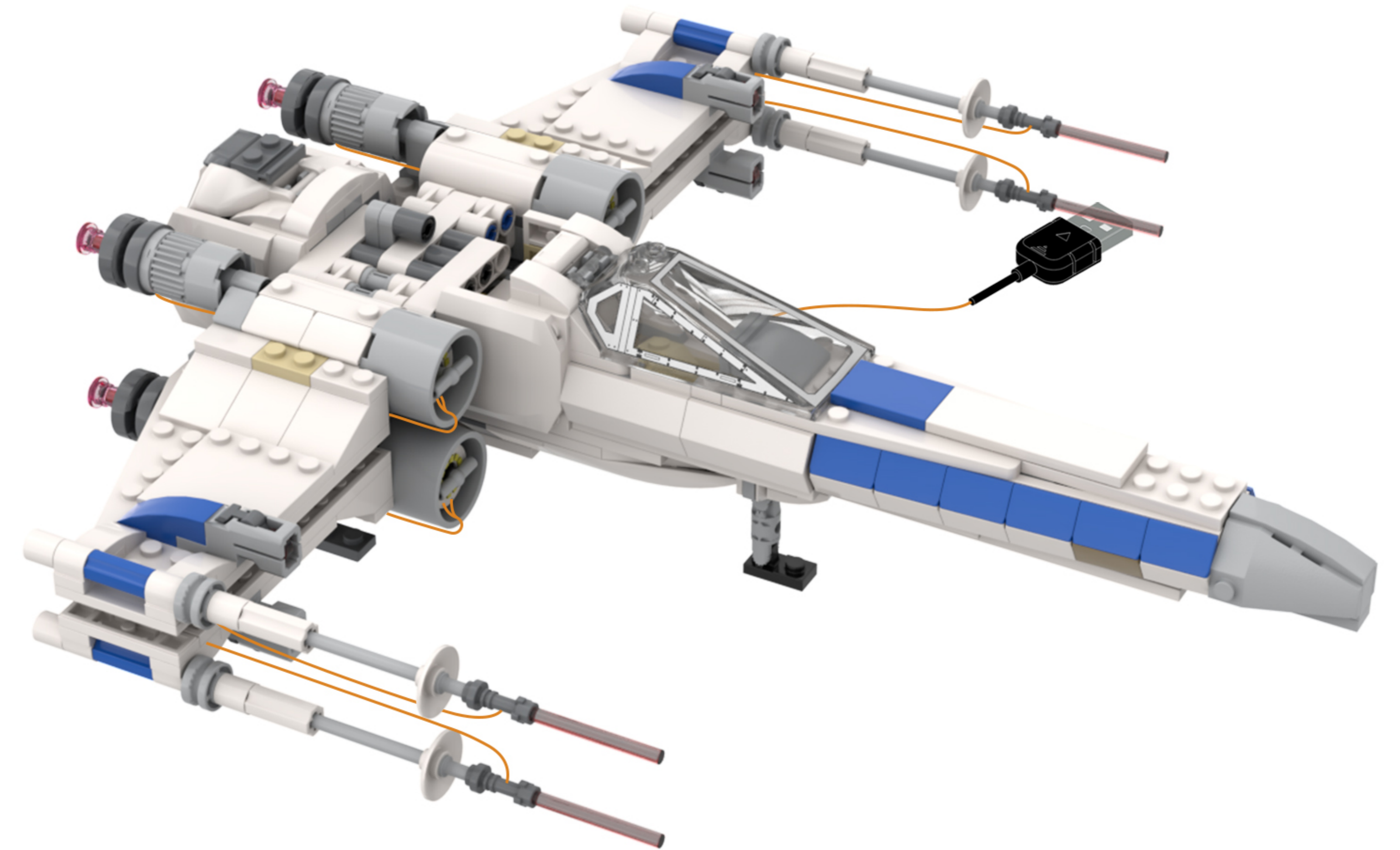



Above our designers to provide the relevant ideas and instructions. But please move to the following:

- 1: about our company this product parts material, product quality do you have comments and suggestions?
- 2: about this product installation instructions and installation of the degree of difficulty do you have views and suggestions?
- 3: if in the operation of the product we provide ideas encountered any problems, please contact us in a timely manner.

## Tips

If you encounter any installation problems please contact the seller, we will be happy to help you solve!