

INSTALLATION GUIDE

Sally's Flowerpot 43288



LED light kit compatible with Lego

Instructions for installing this kit:

This set includes 3 pouches. (The battery case functions similarly; please select your own power source. This article uses a USB power cable.)

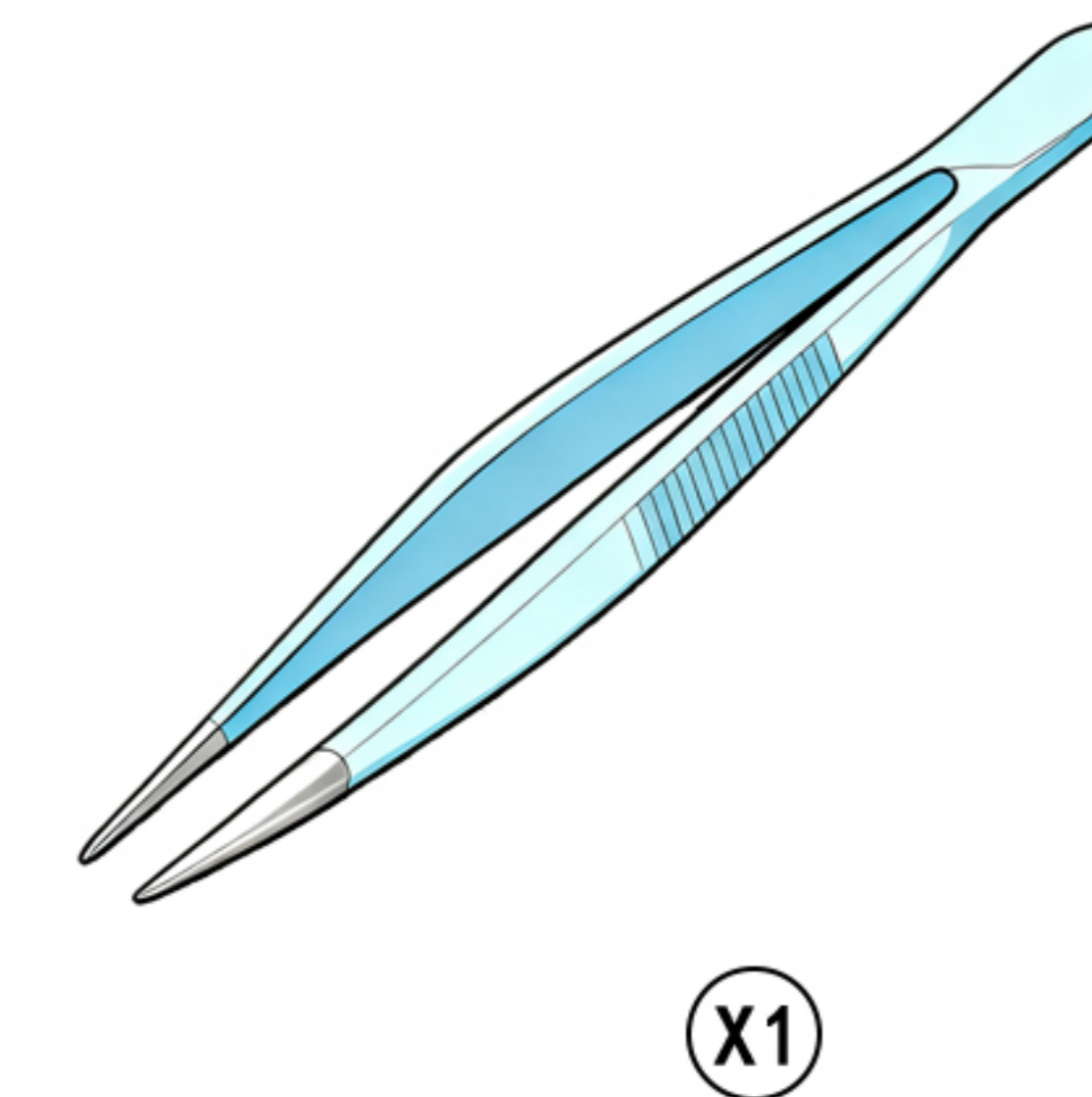
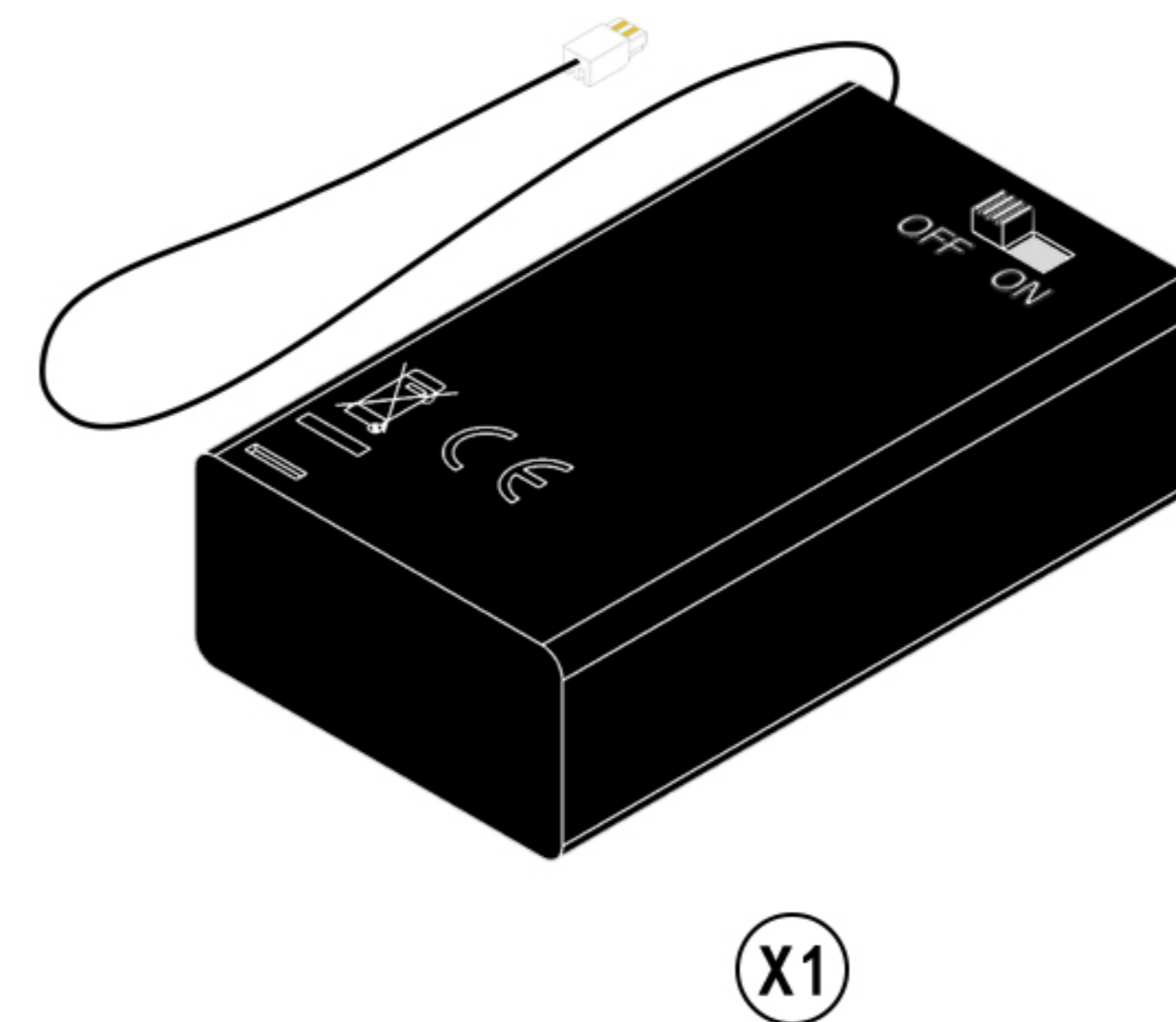
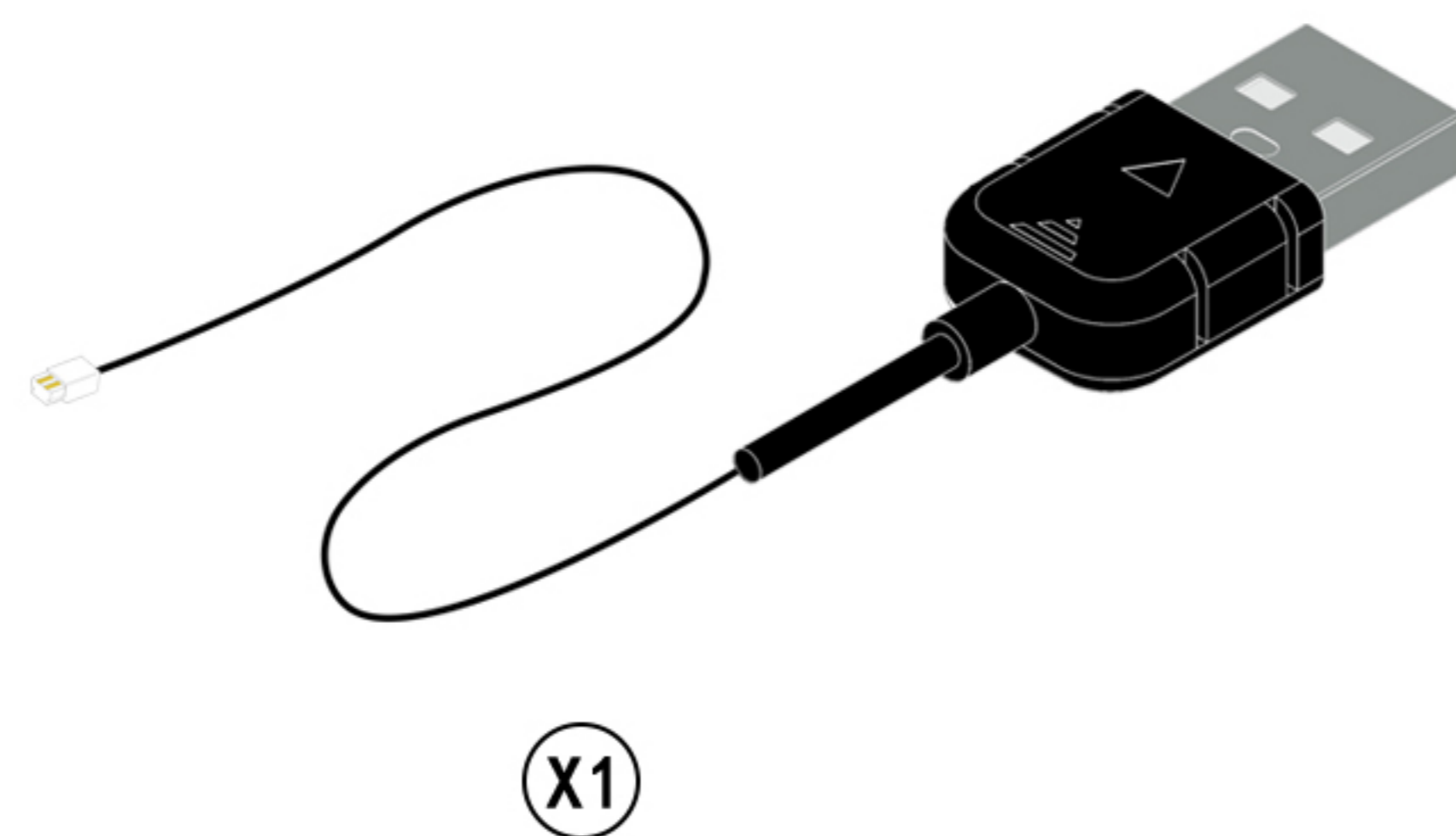
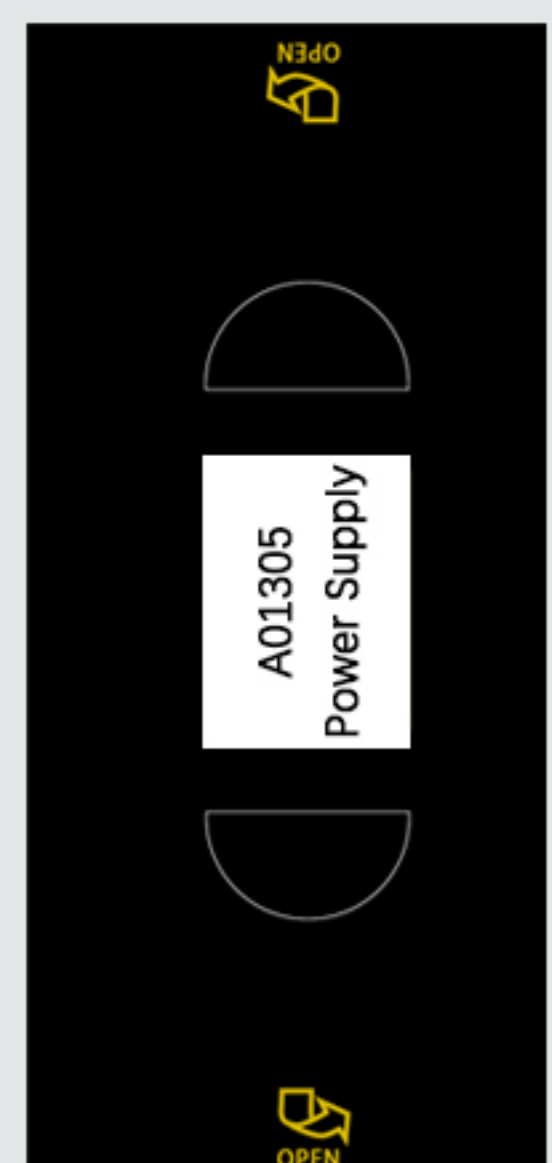
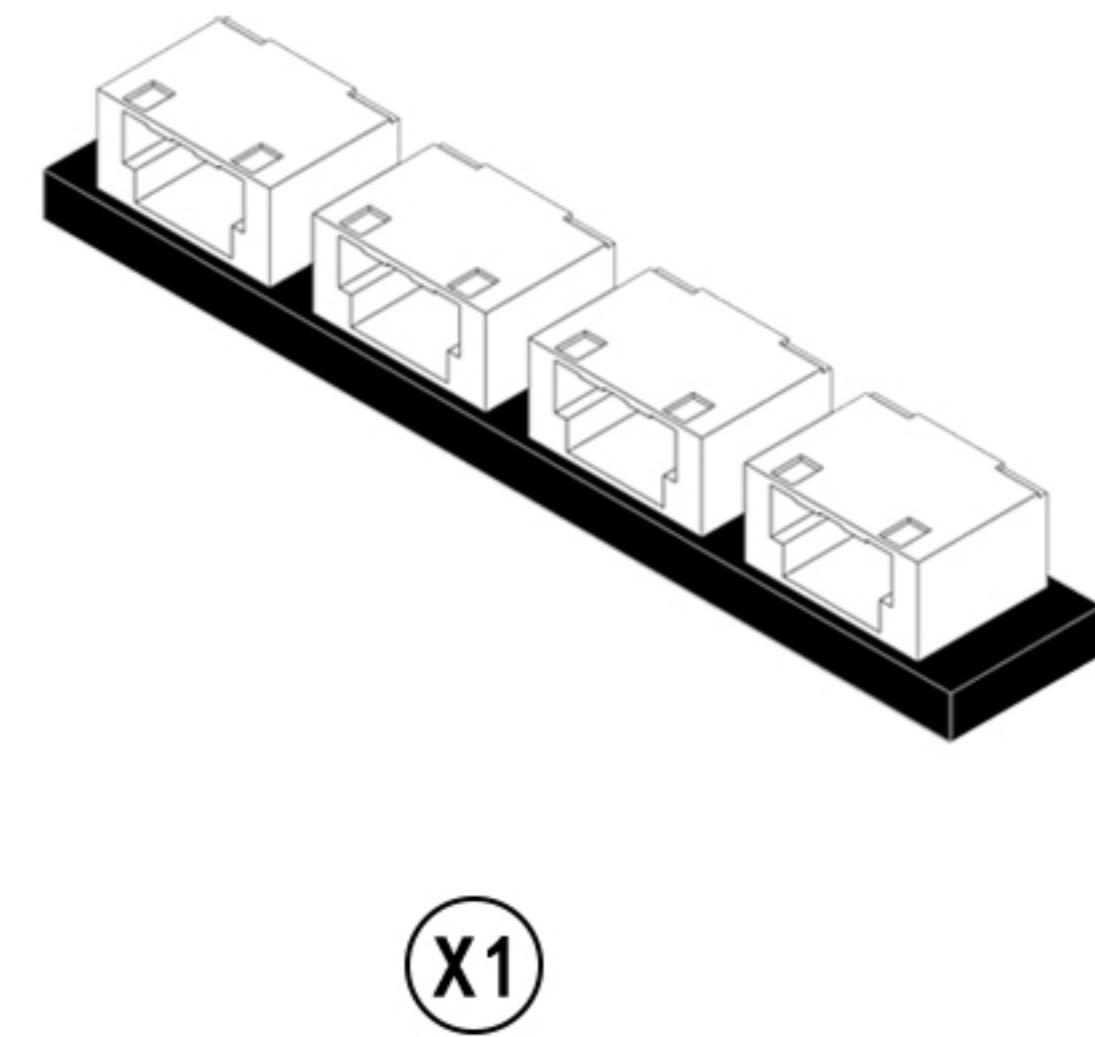
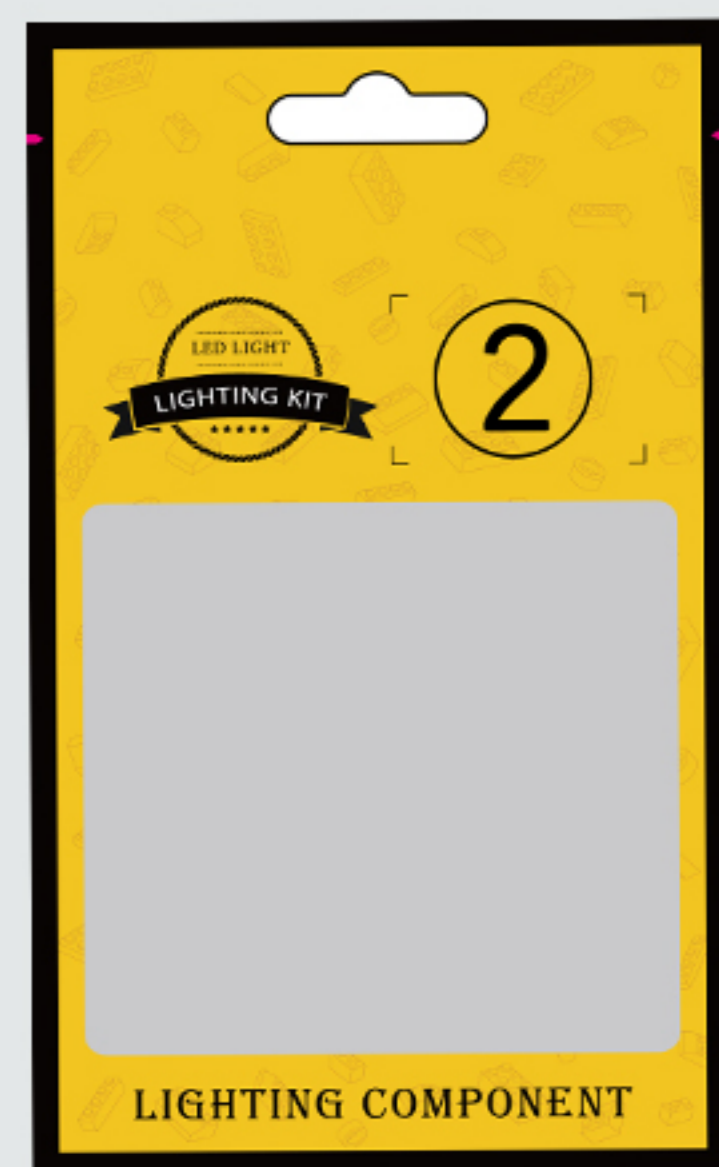
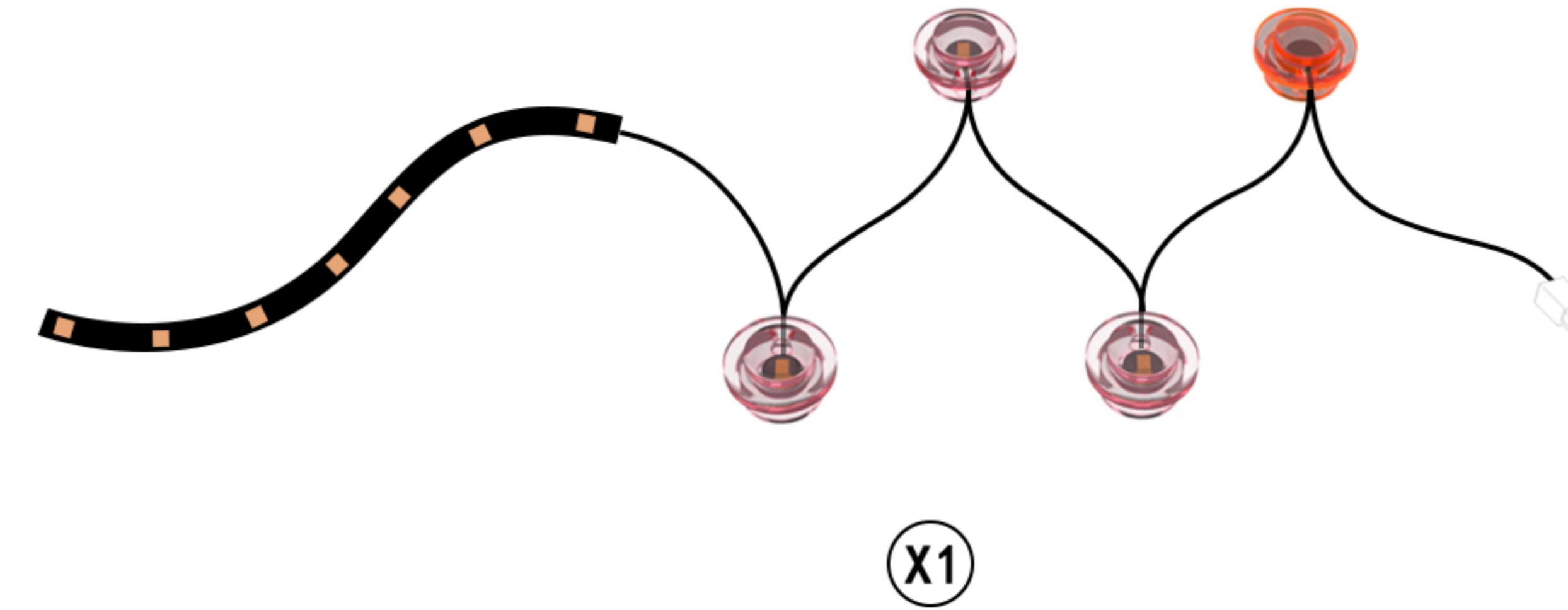
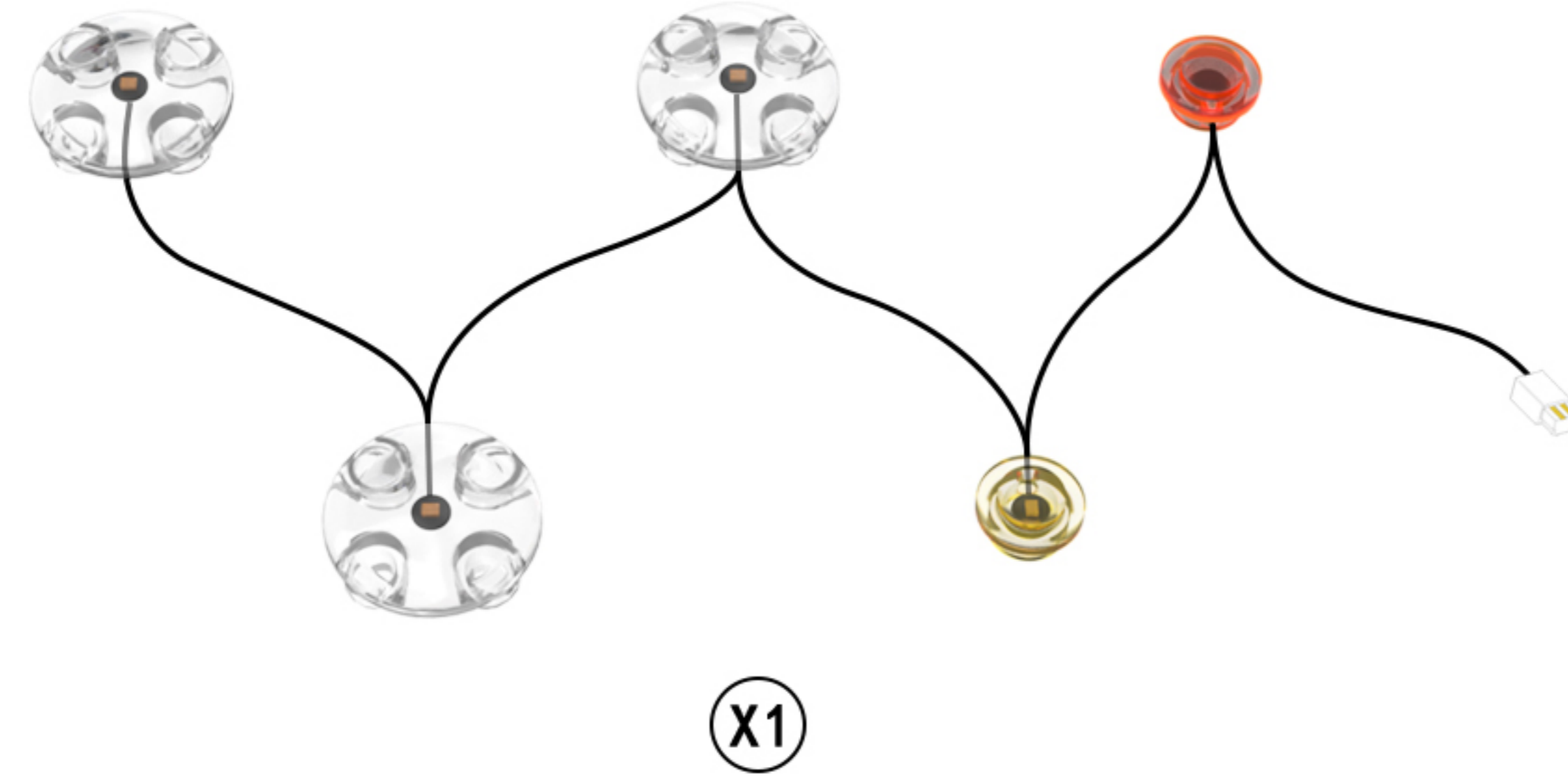

This post will complete the light installation in two main sections.

Step 1-test



Step 2-mounting

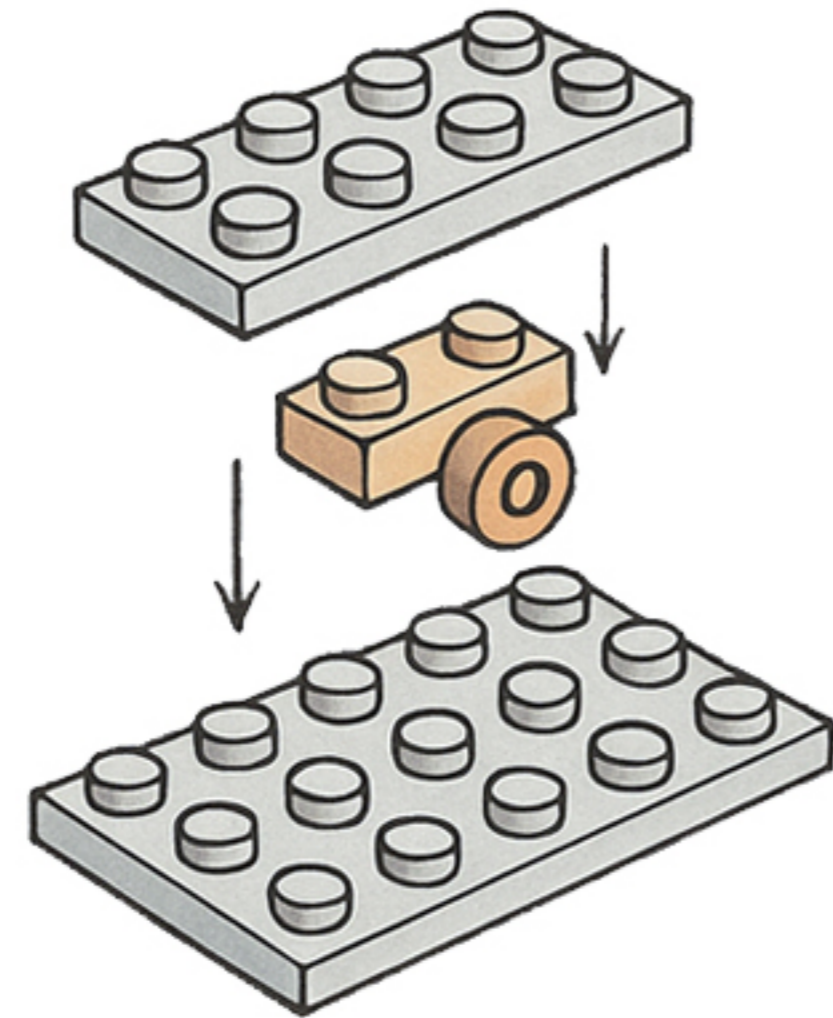

So let's get started!

Step 1-Test.

1

EN: Remove the expansion board from Bag 2.

DE: Entnehmen Sie die Erweiterungskarte aus Beutel 2.

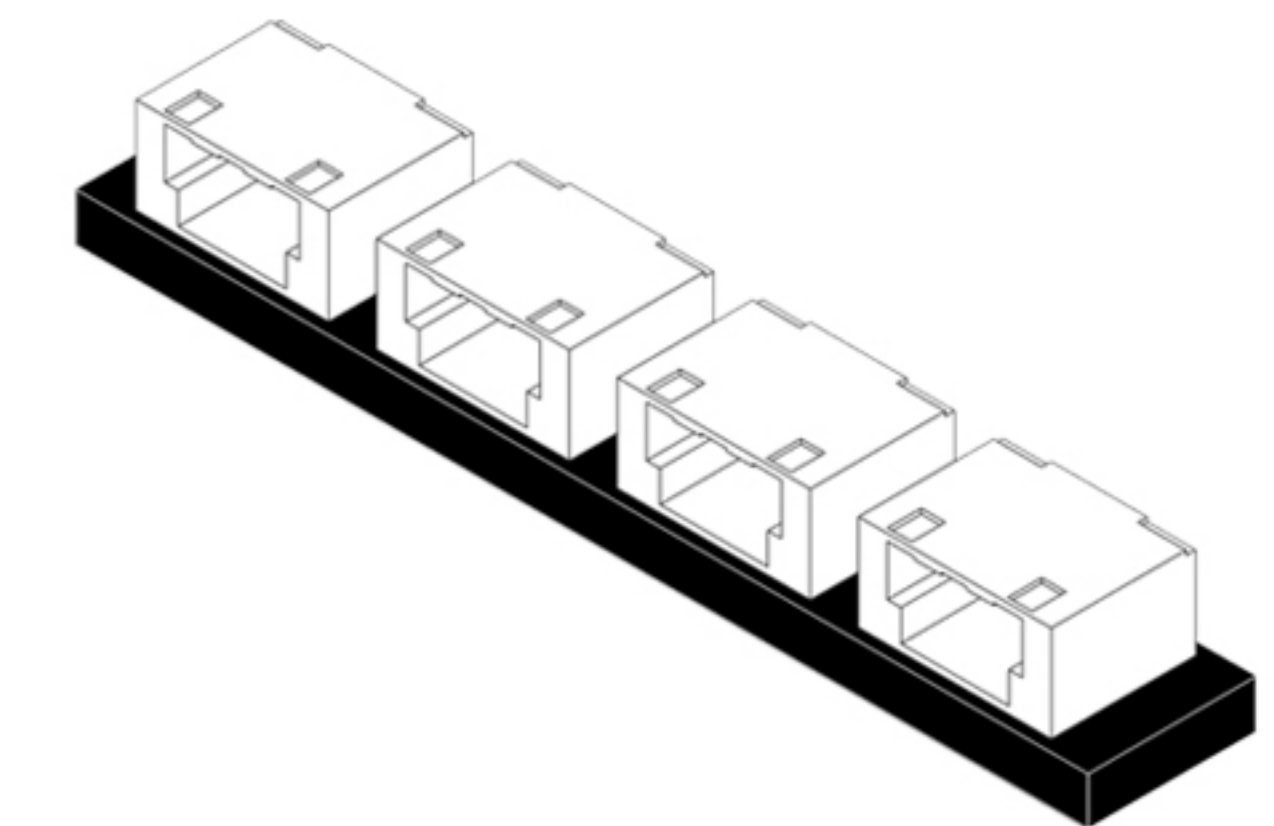

x1

2

EN: Remove the USB power cable from the bag and connect it to the expansion board.

DE: Entnehmen Sie das USB-Stromkabel aus der Tasche und schließen Sie es an die Erweiterungskarte an.

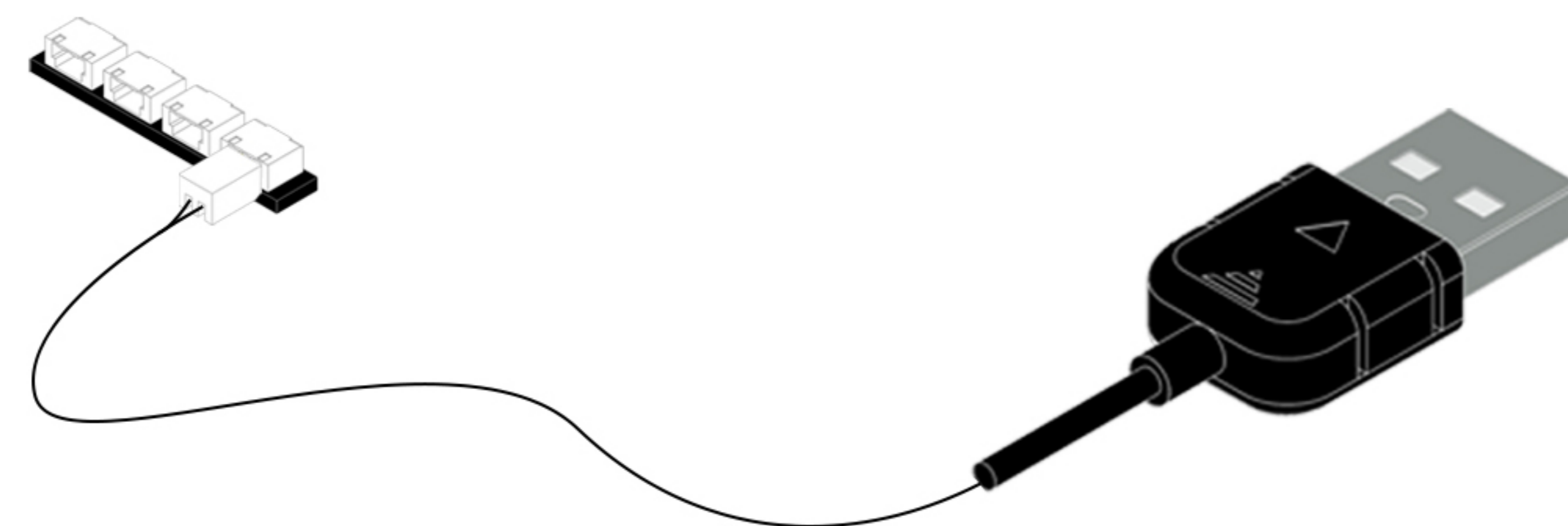
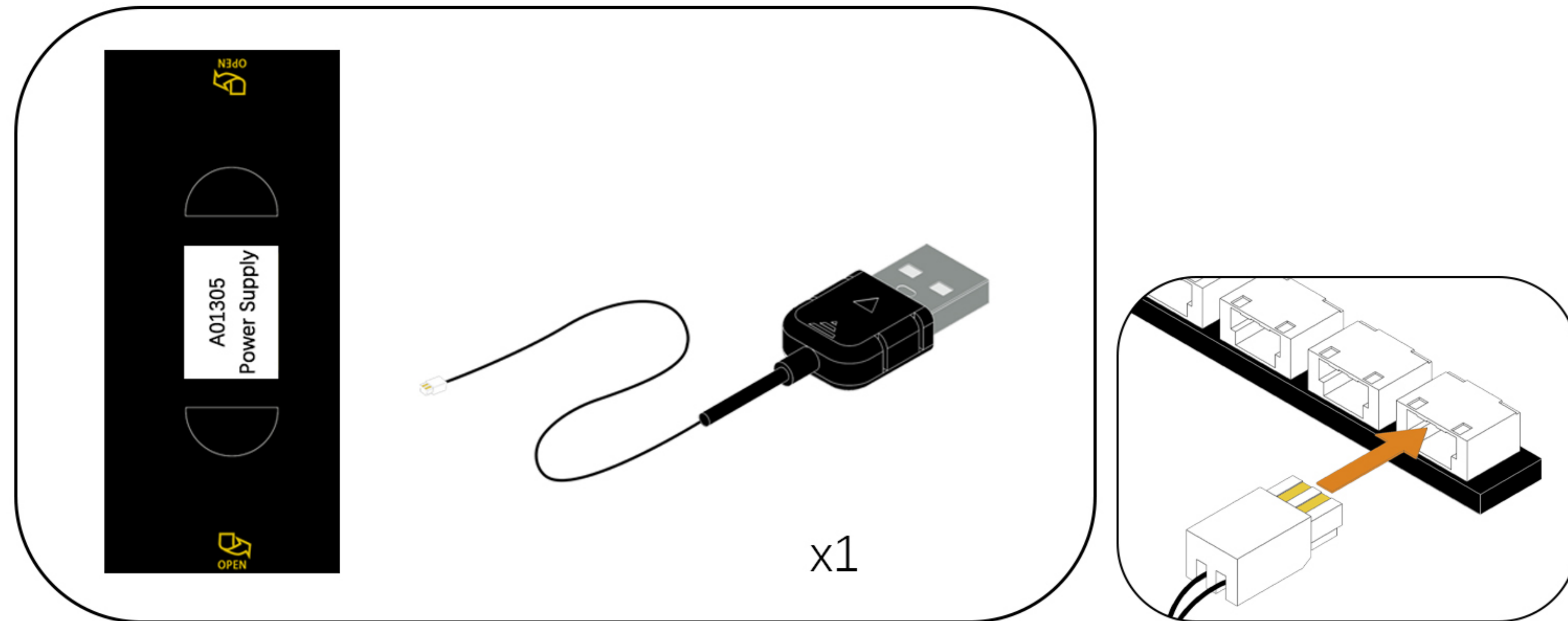

3

EN: Connect the USB power cable to the mobile power supply. (Power supply not included; see the diagram below for power supply options.)

DE: Schließen Sie das USB-Netz-kabel an die mobile Stromversorgung an. (Stromversorgung nicht im Lieferumfang enthalten, siehe Abbildung unten für die Stromversorgungsart.)

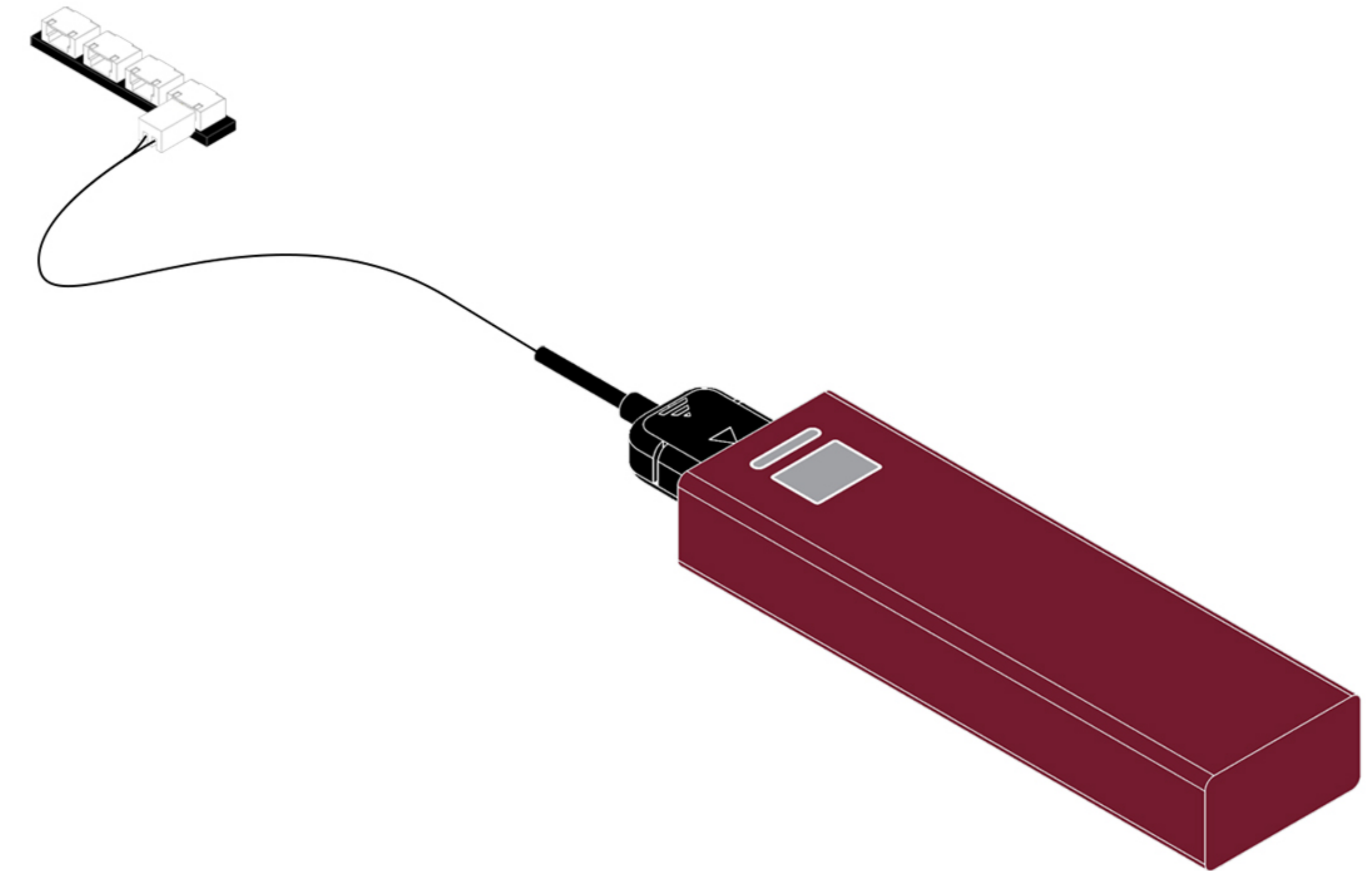

USB Connectors to Connect Devices

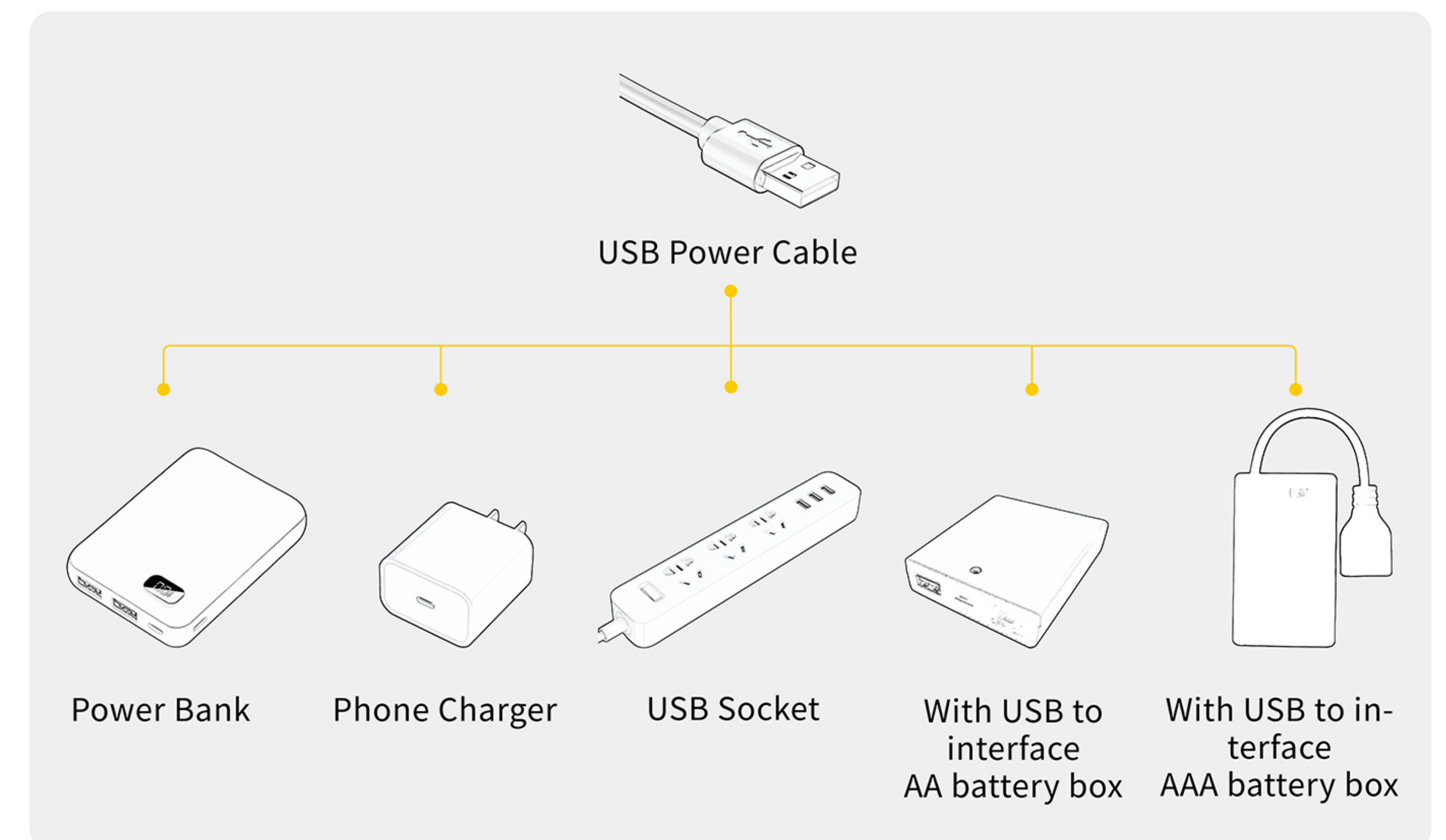

4

EN: Remove the string of lights from Bag 1 and connect it to the extension board. Turn on the power and check that the lights are working properly. If you notice any issues, please contact us immediately.

DE: Nehmen Sie die Lichterkette aus Beutel 1 heraus und schließen Sie sie an die Verlängerungsplatine an. Schalten Sie den Strom ein und überprüfen Sie, ob die Lichter ordnungsgemäß funktionieren. Sollten Sie Probleme feststellen, kontaktieren Sie uns bitte umgehend.

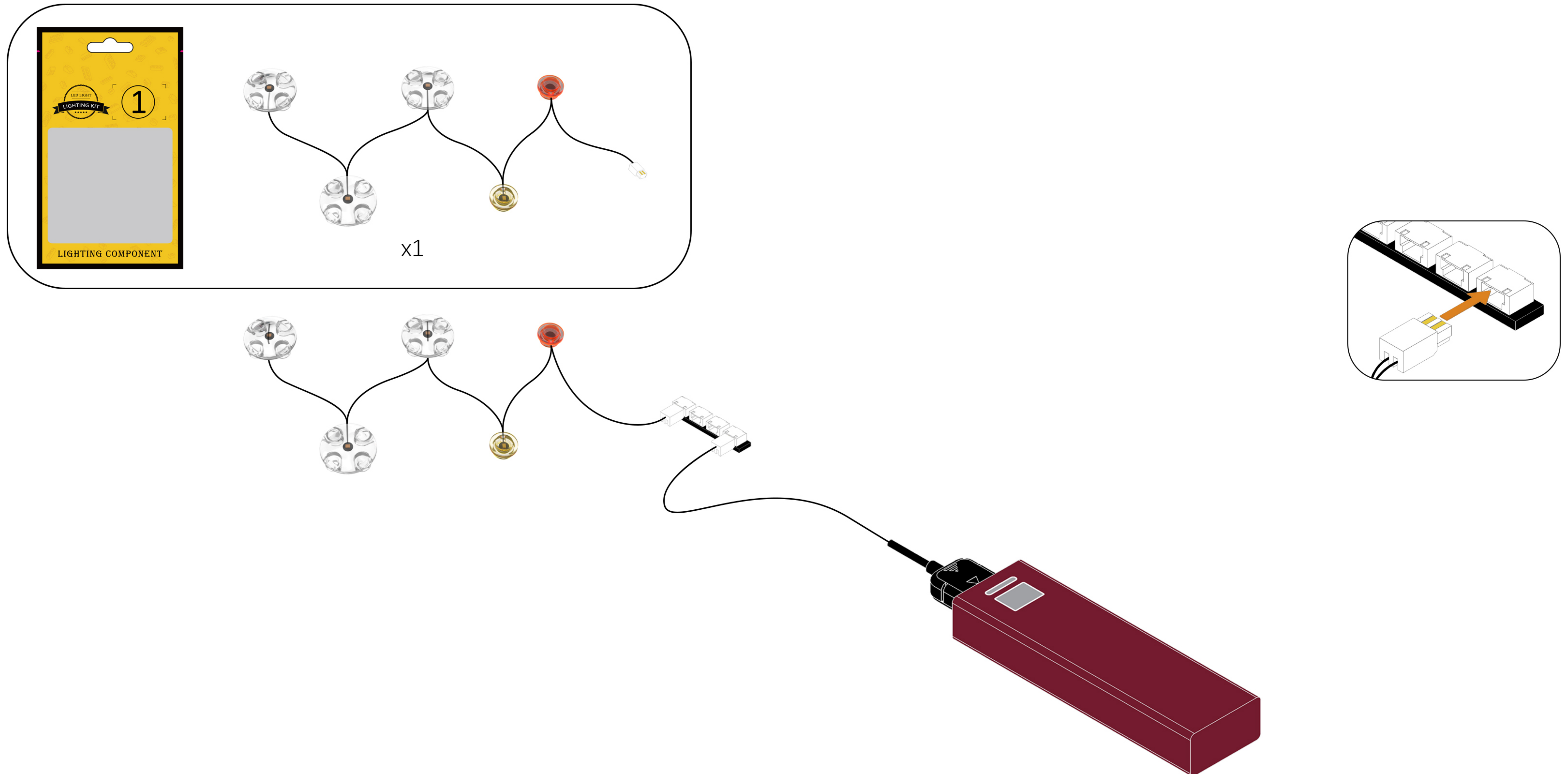

After confirming that there are no abnormalities, temporarily return each part to its original bag.

Step 2-Mounting.

1

EN: Take out the building block model.

DE: Nimm das Bauklotzmodell heraus.



2

EN: Open the building blocks.

DE: Öffne die Bausteine.



3

EN: Adjust your perspective.

DE: Ändern Sie Ihre Perspektive.

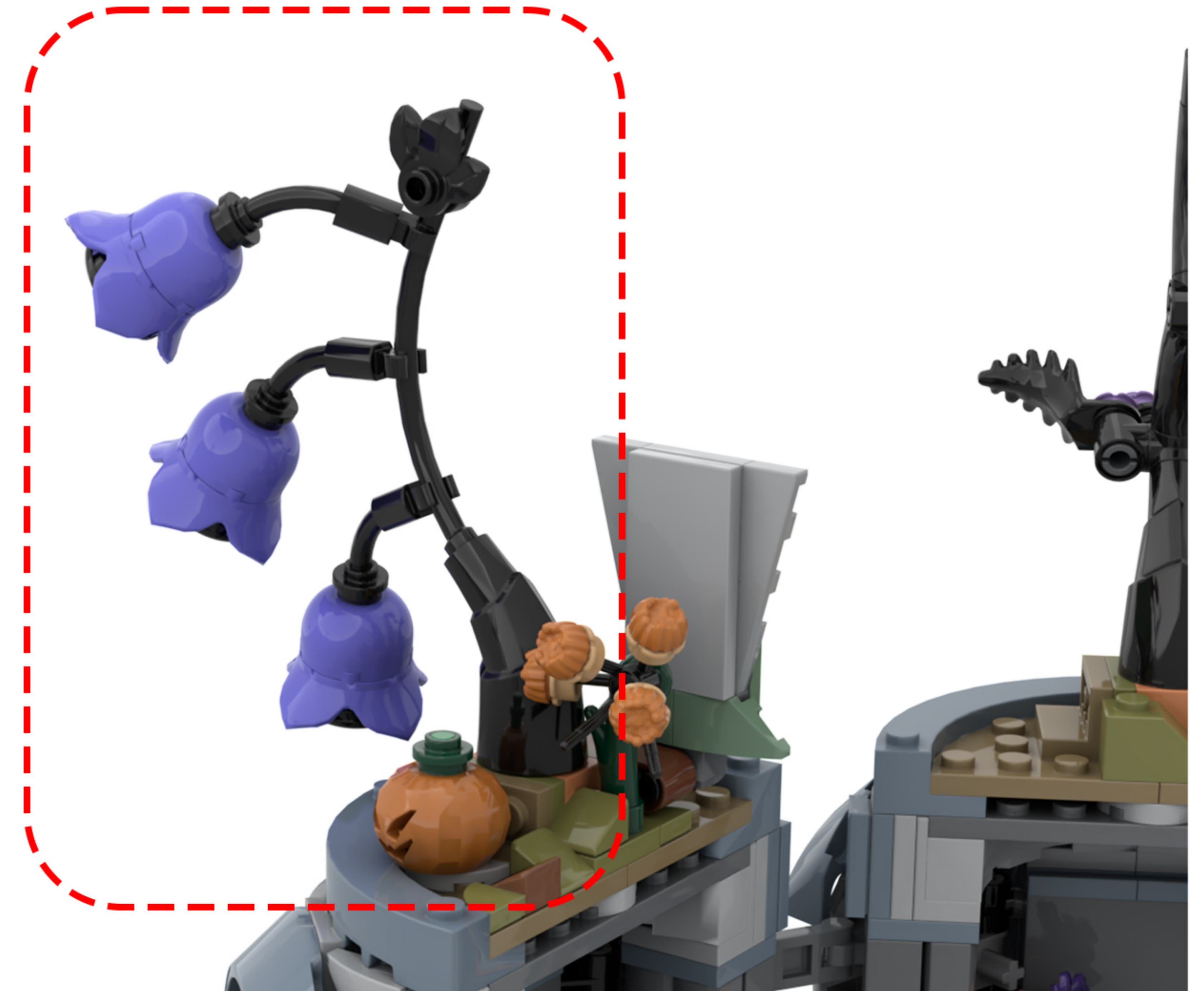

4

EN: Remove the building blocks one by one.

DE: Entfernen Sie die Bausteine nacheinander.

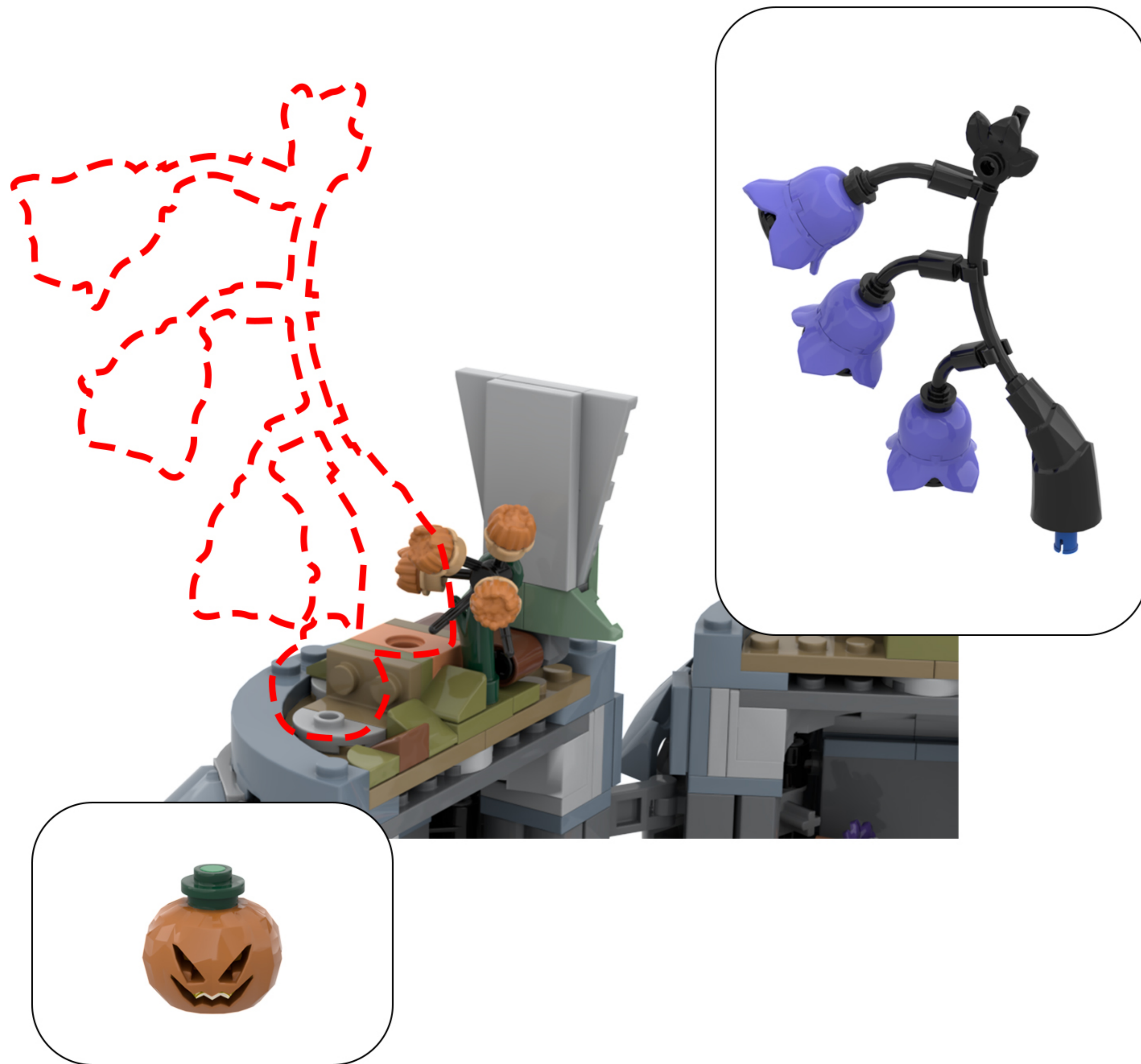

5

EN: Take out the disassembled building blocks and separate them.

DE: Nehmen Sie die zerlegten Bausteine heraus und trennen Sie sie voneinander.

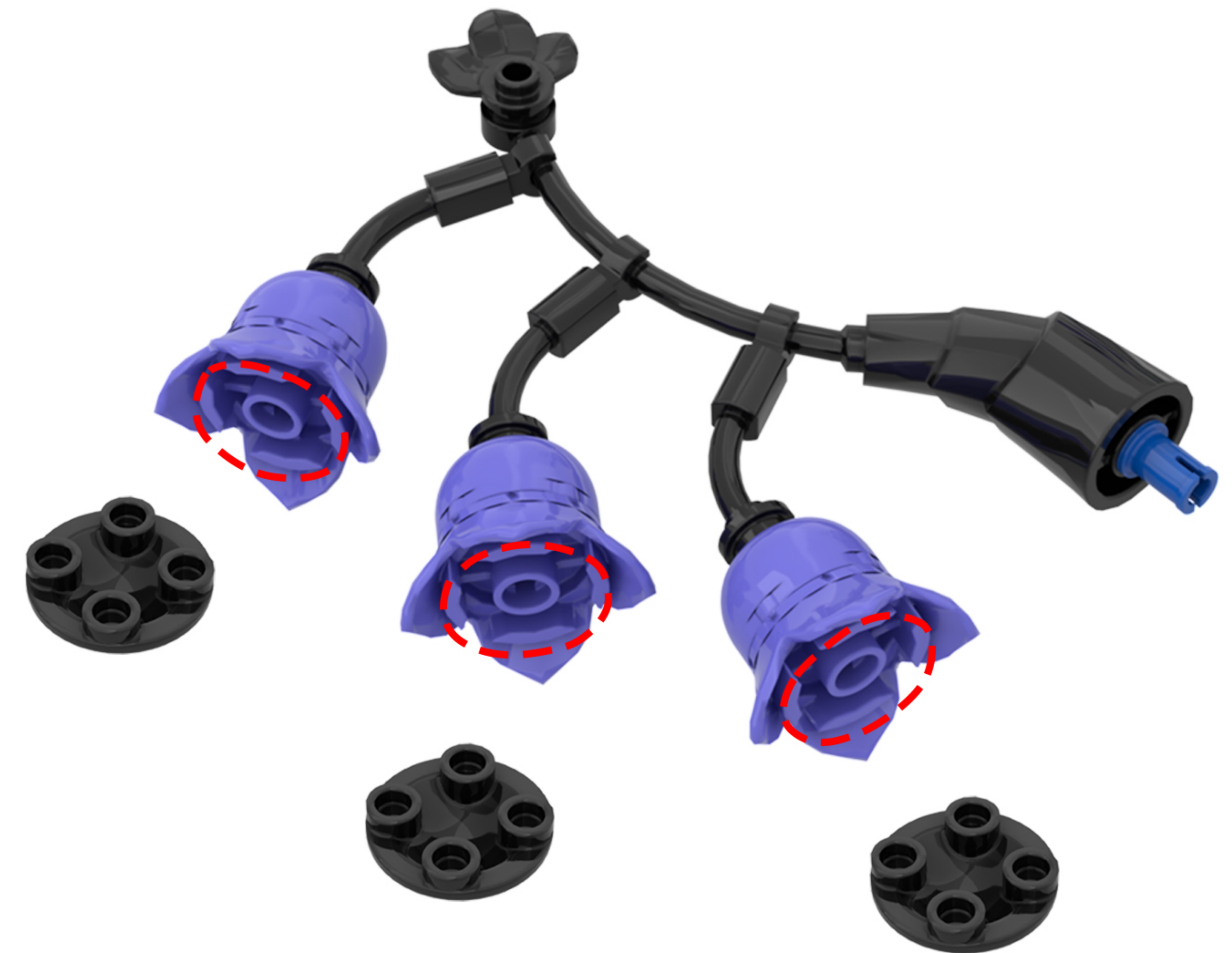
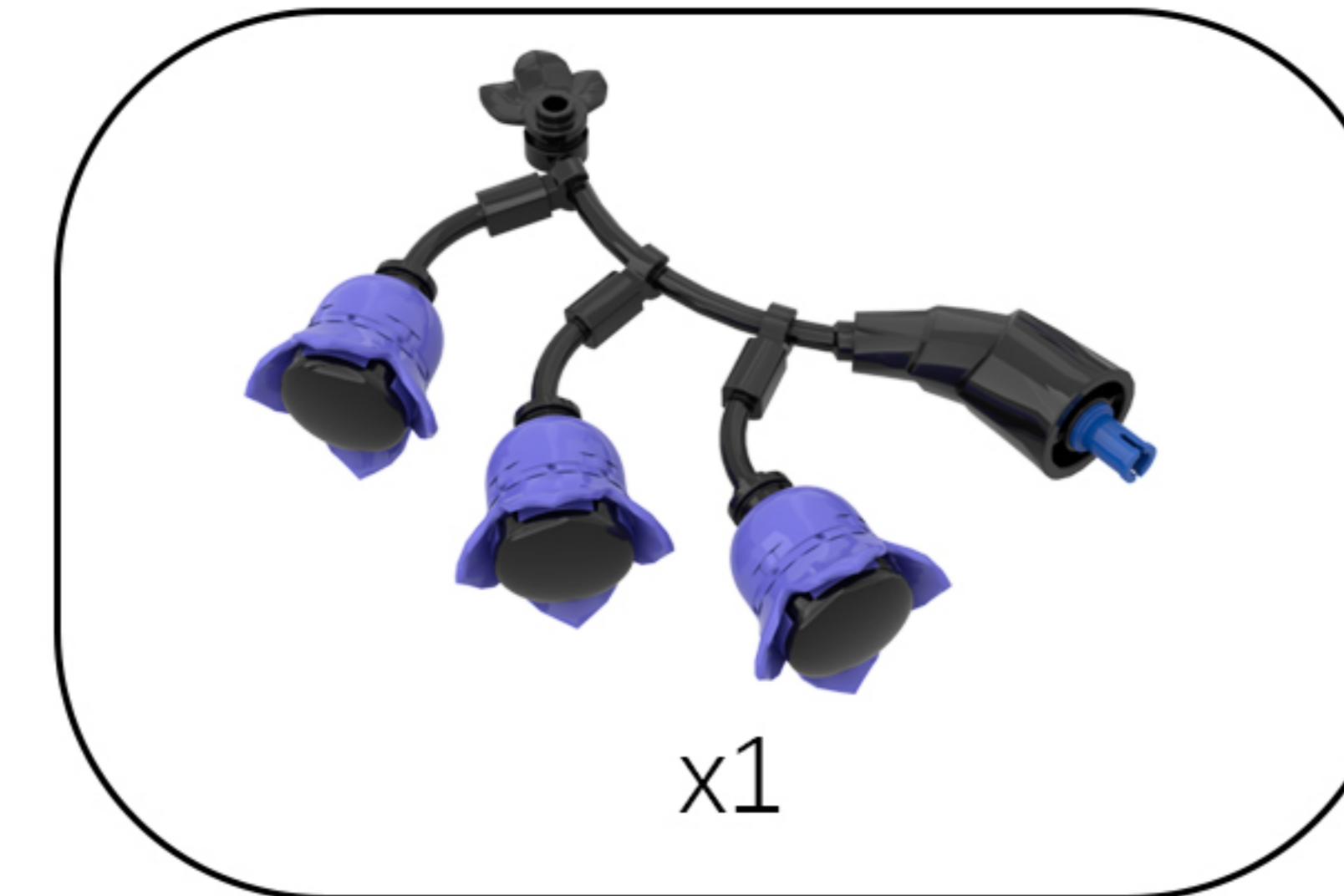

6

EN: Take the string of lights out of Bag 1, untie the zip tie, and locate the decorative lights on the string.

DE: Nimm die Lichterkette aus Beutel 1, löse den Kabelbinder und suche die dekorativen Lichter an der Kette.

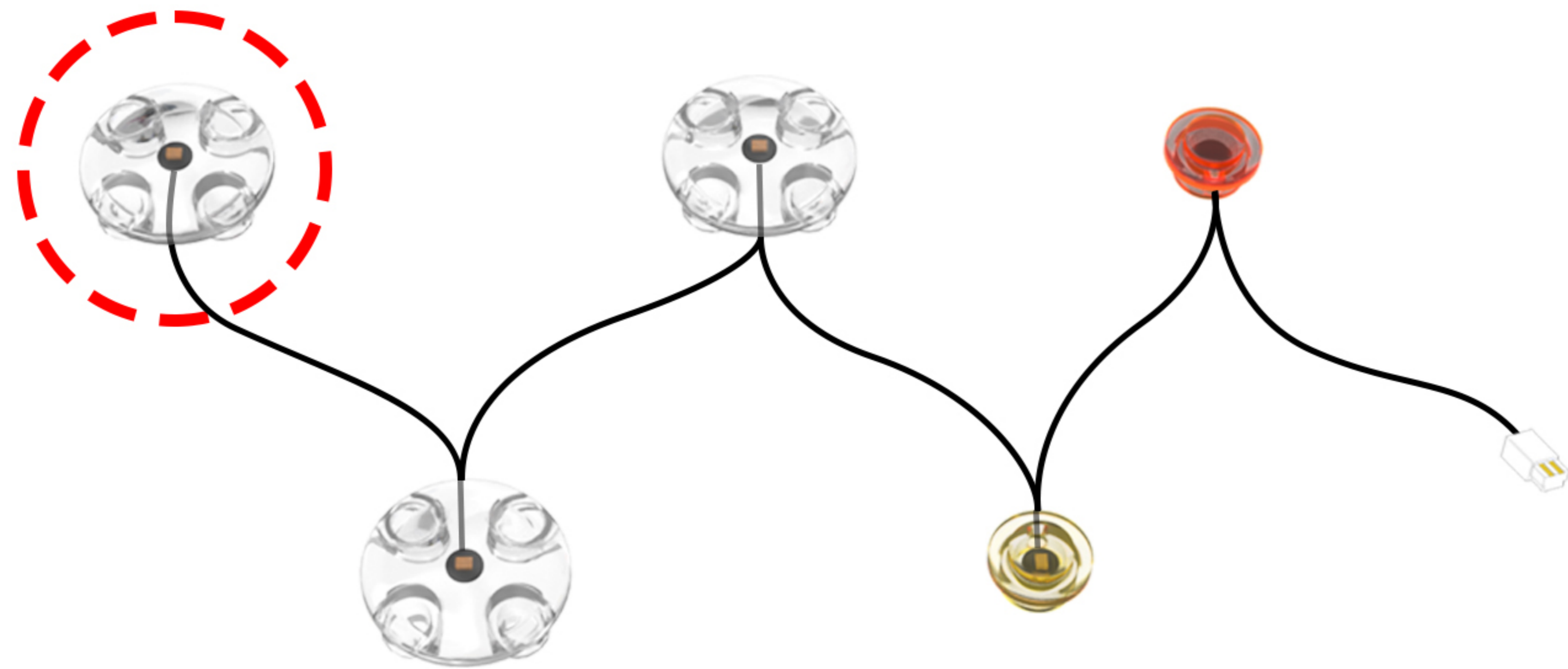
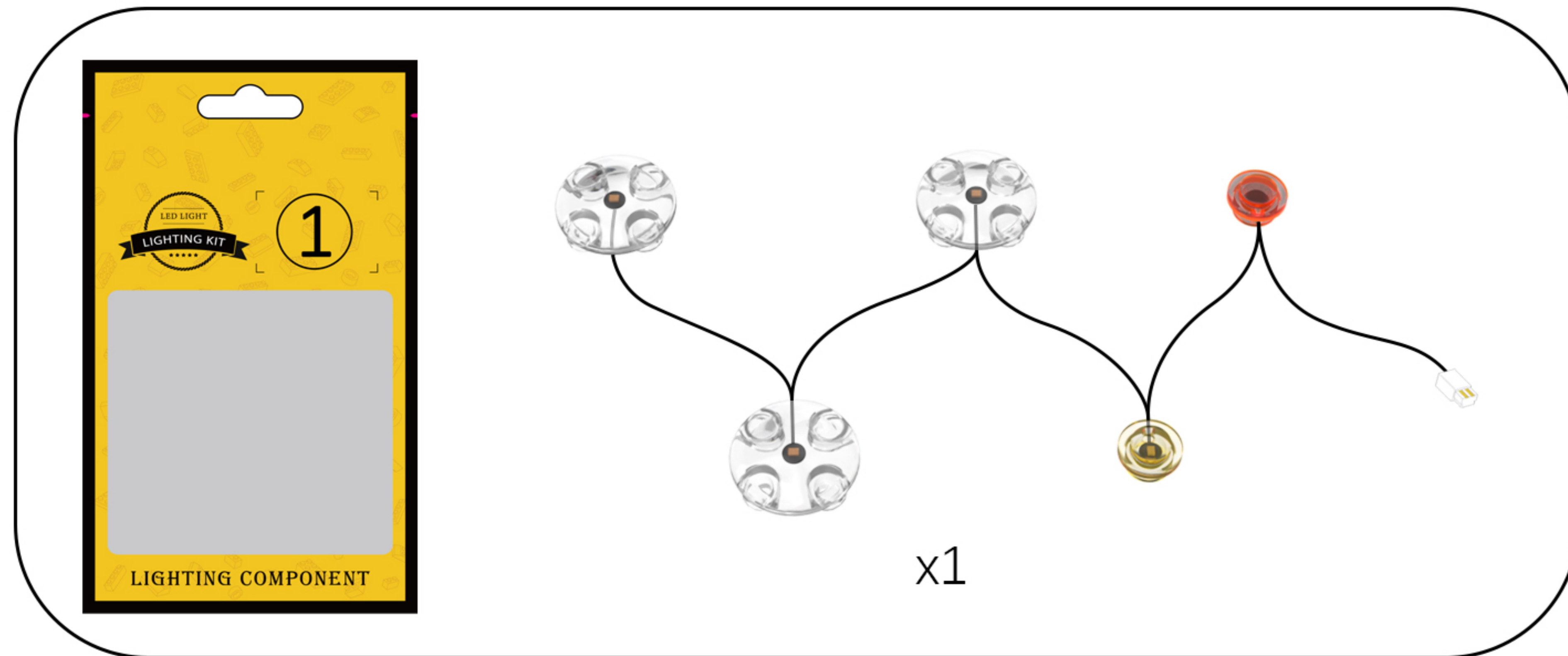

7

EN: Install the light fixture onto the building block.

DE: Installieren Sie die Leuchte auf dem Baustein.

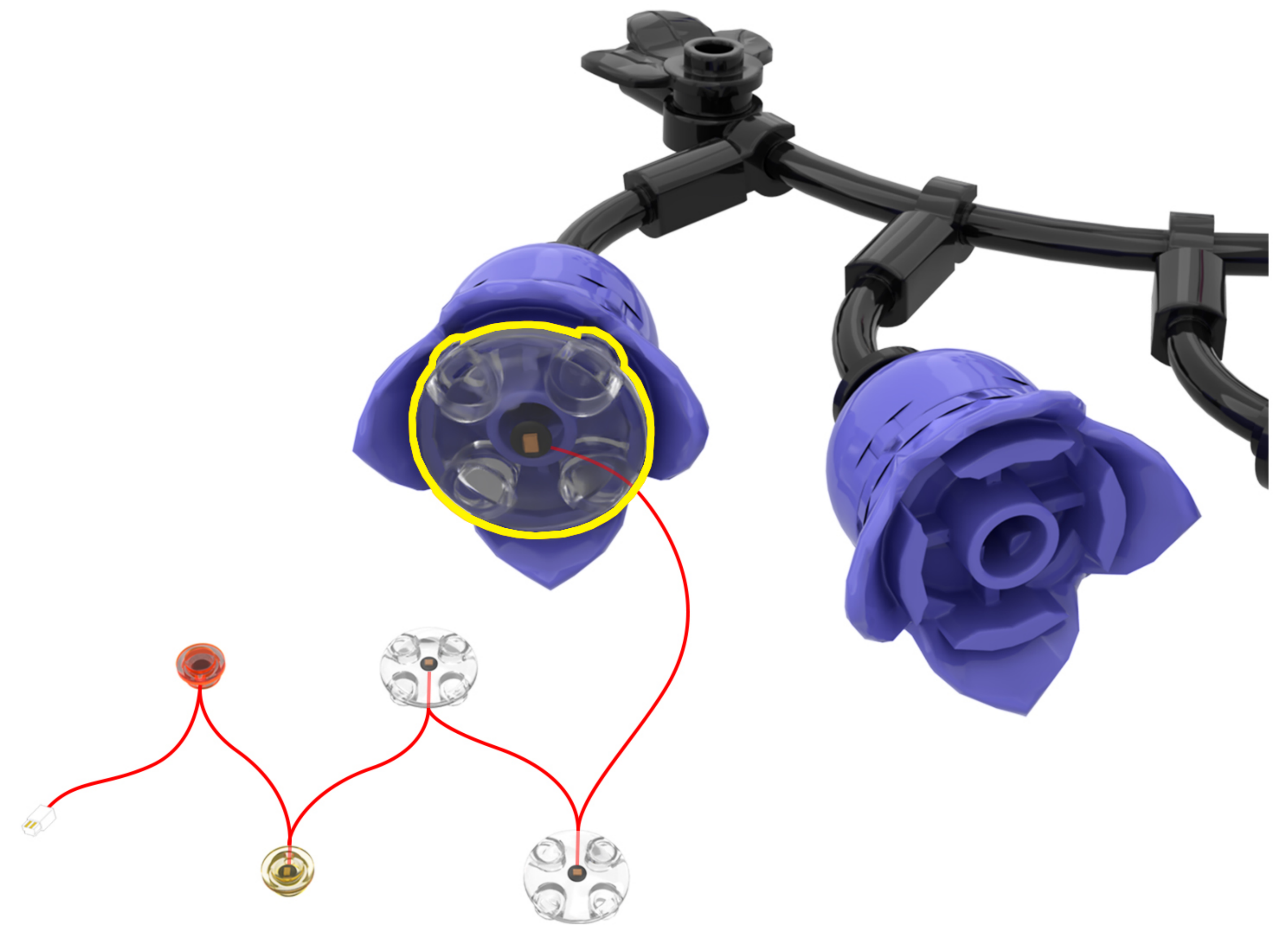

8

EN: Wrap the light cord around the building block.

DE: Wickle das Lichterkabel um den Baustein.

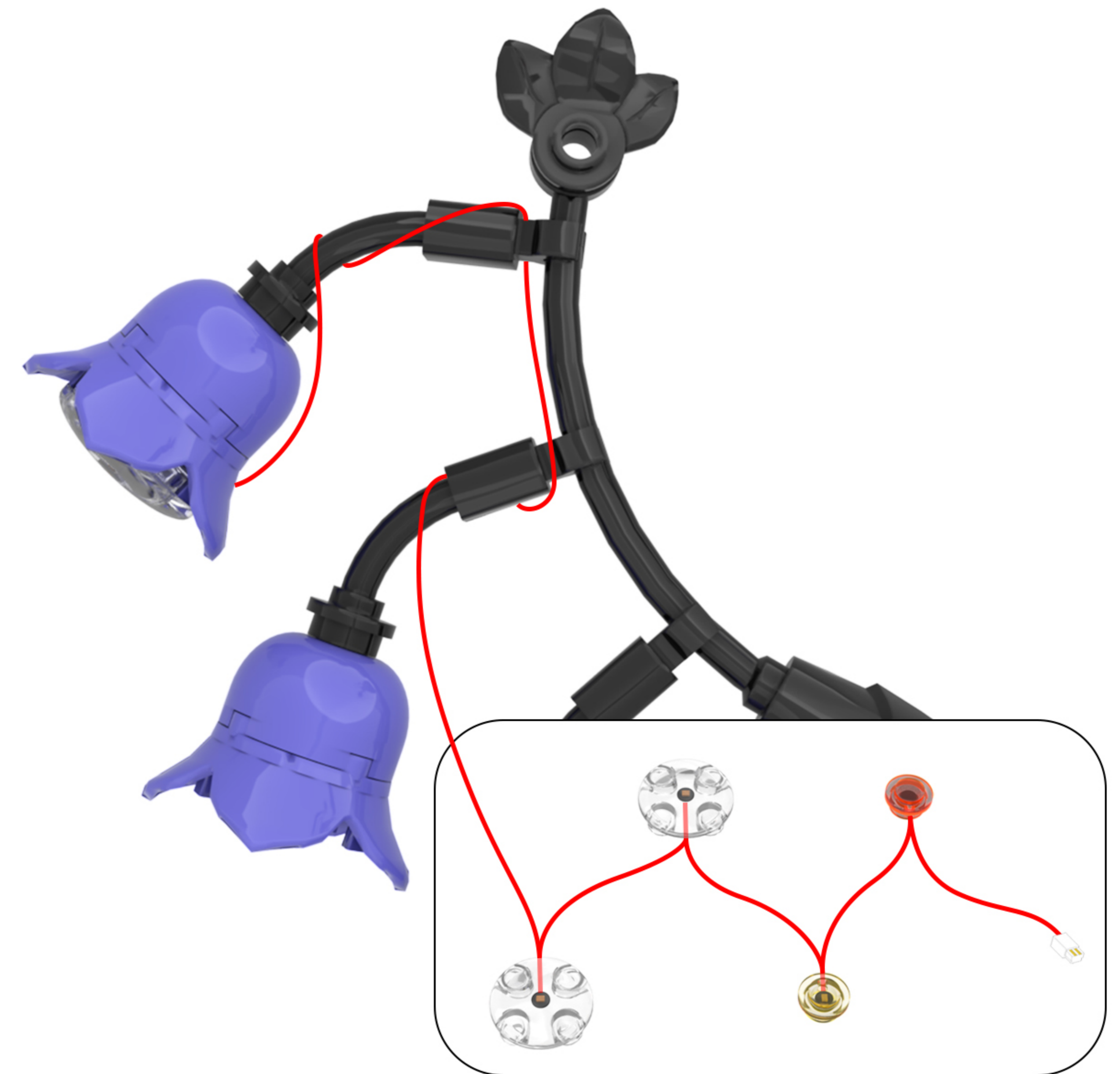
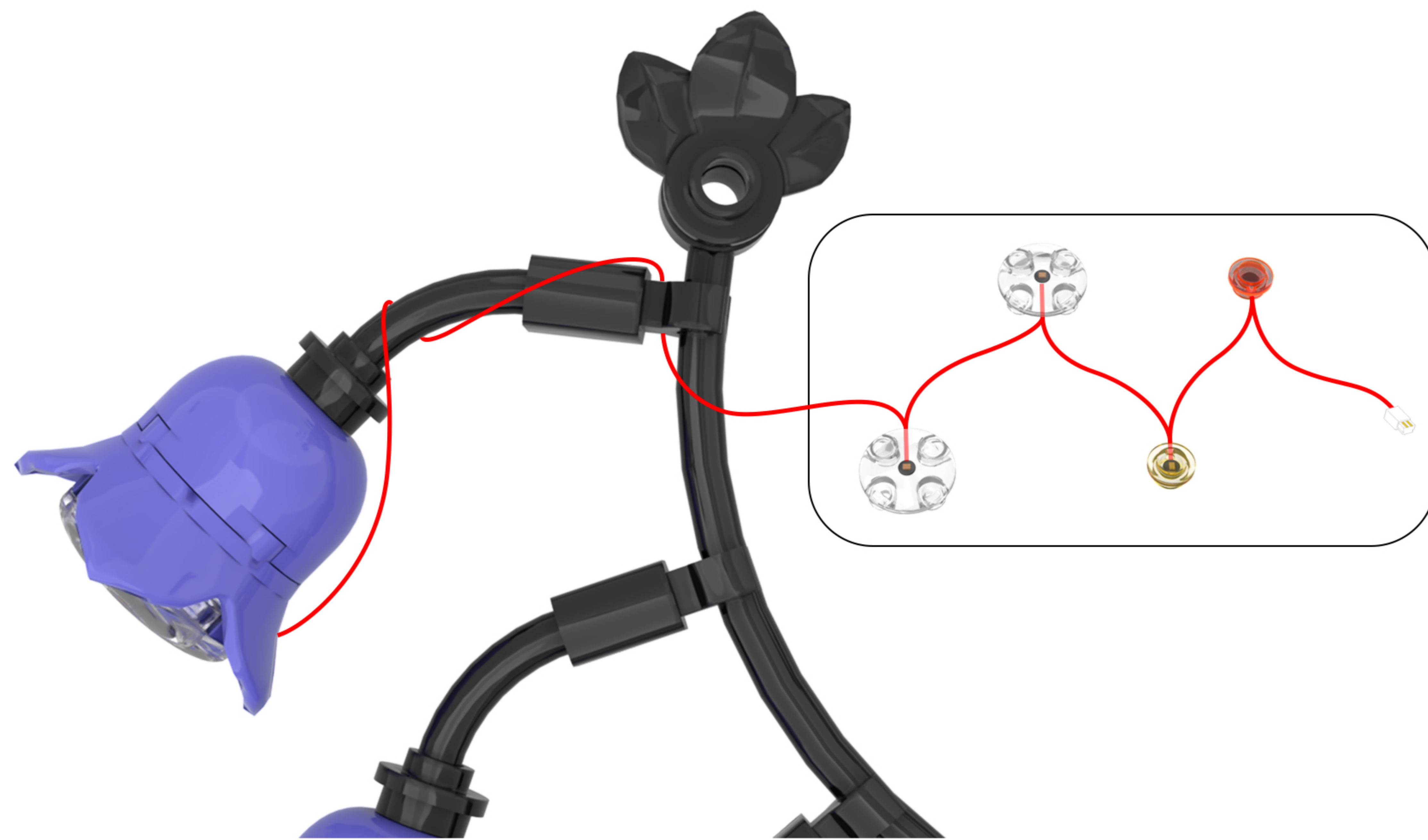

9

EN: Attach the lights from the string to the building blocks.

DE: Befestigen Sie die Lichter der Lichterkette an den Bausteinen.

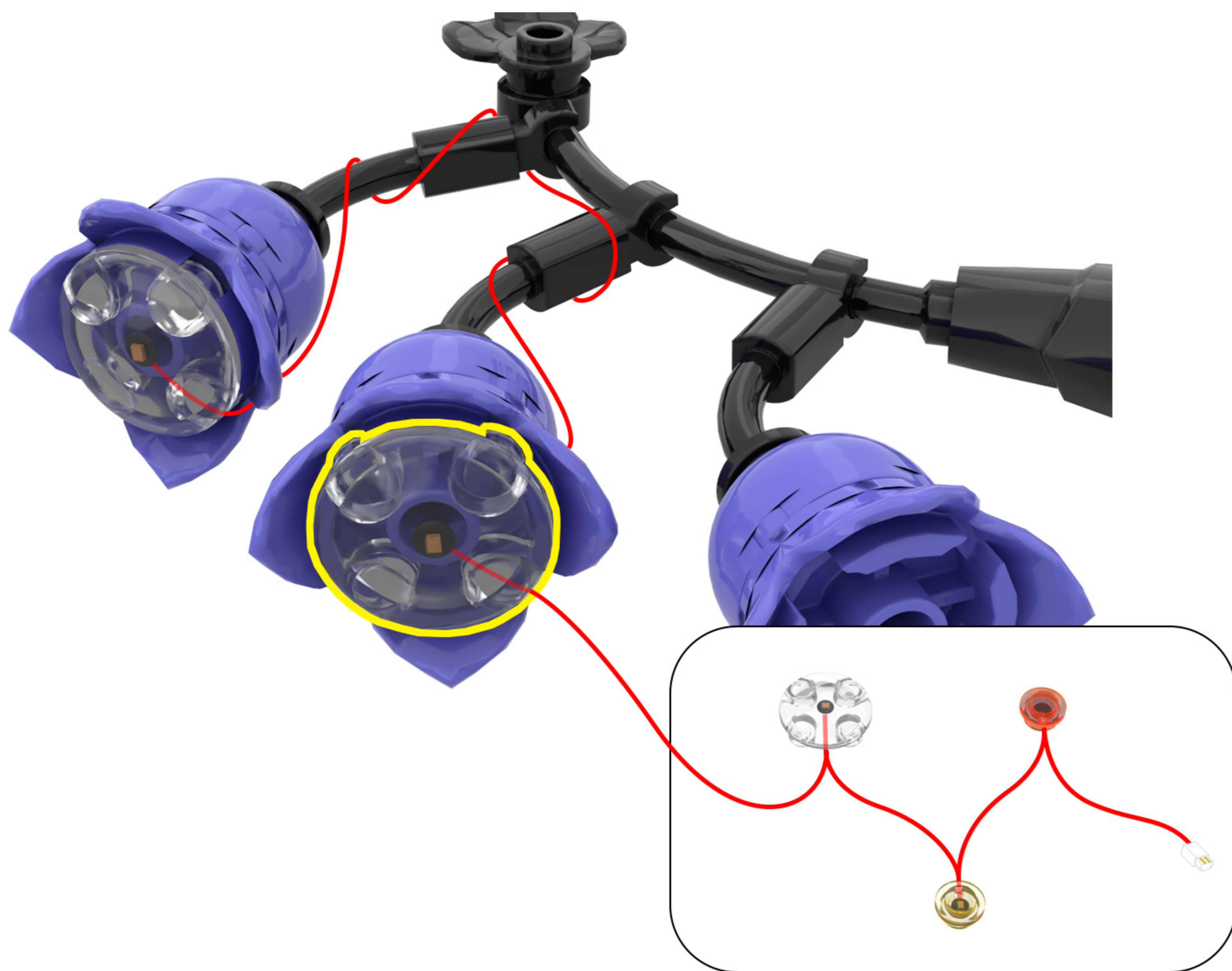

10

EN: Wrap the light cord back around the building block.

DE: Wickle das Lichtkabel wieder um den Baustein.

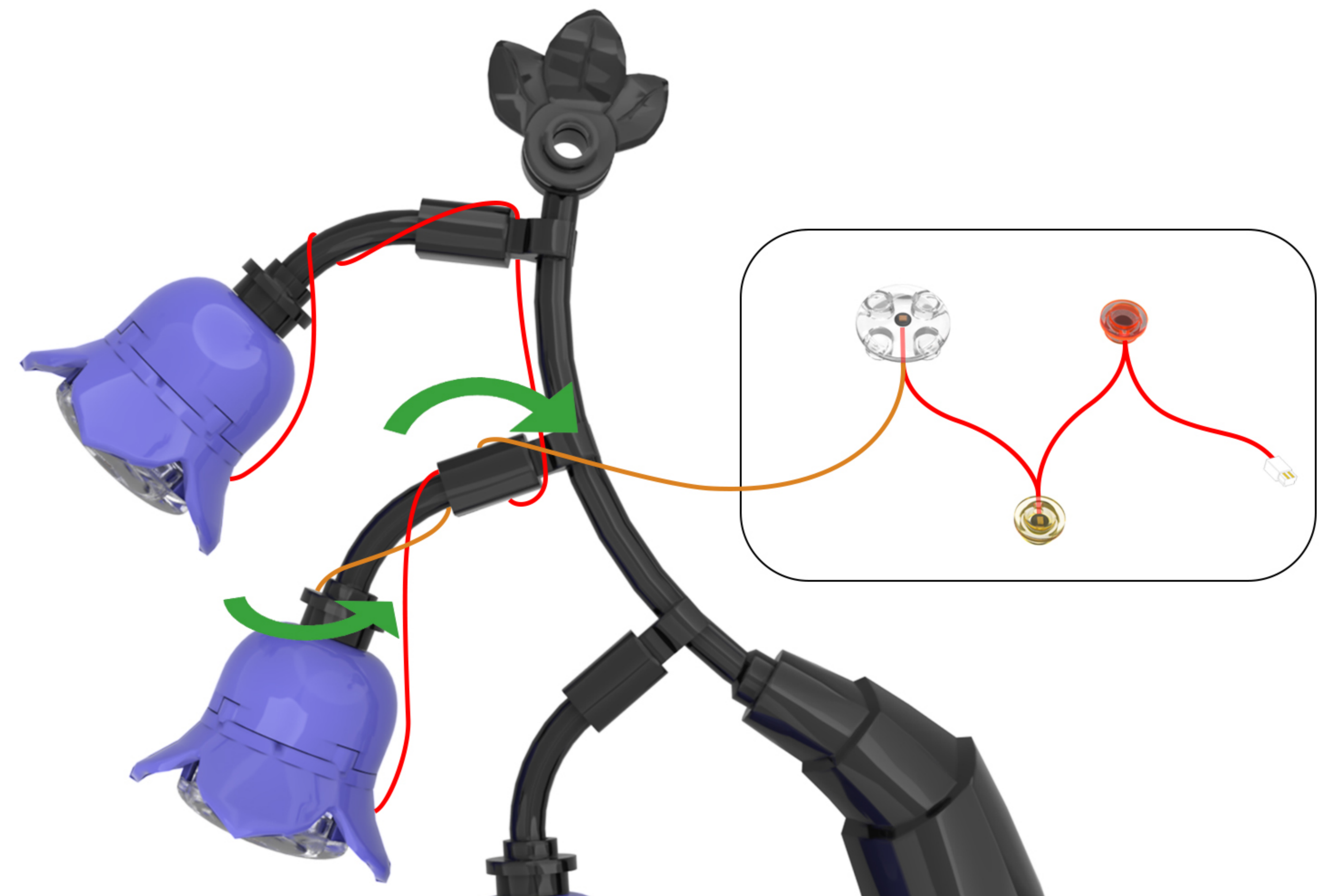

11

EN: Continue wrapping the light cord around the building block.

DE: Wickeln Sie das Lichterkabel weiter um den Baustein.

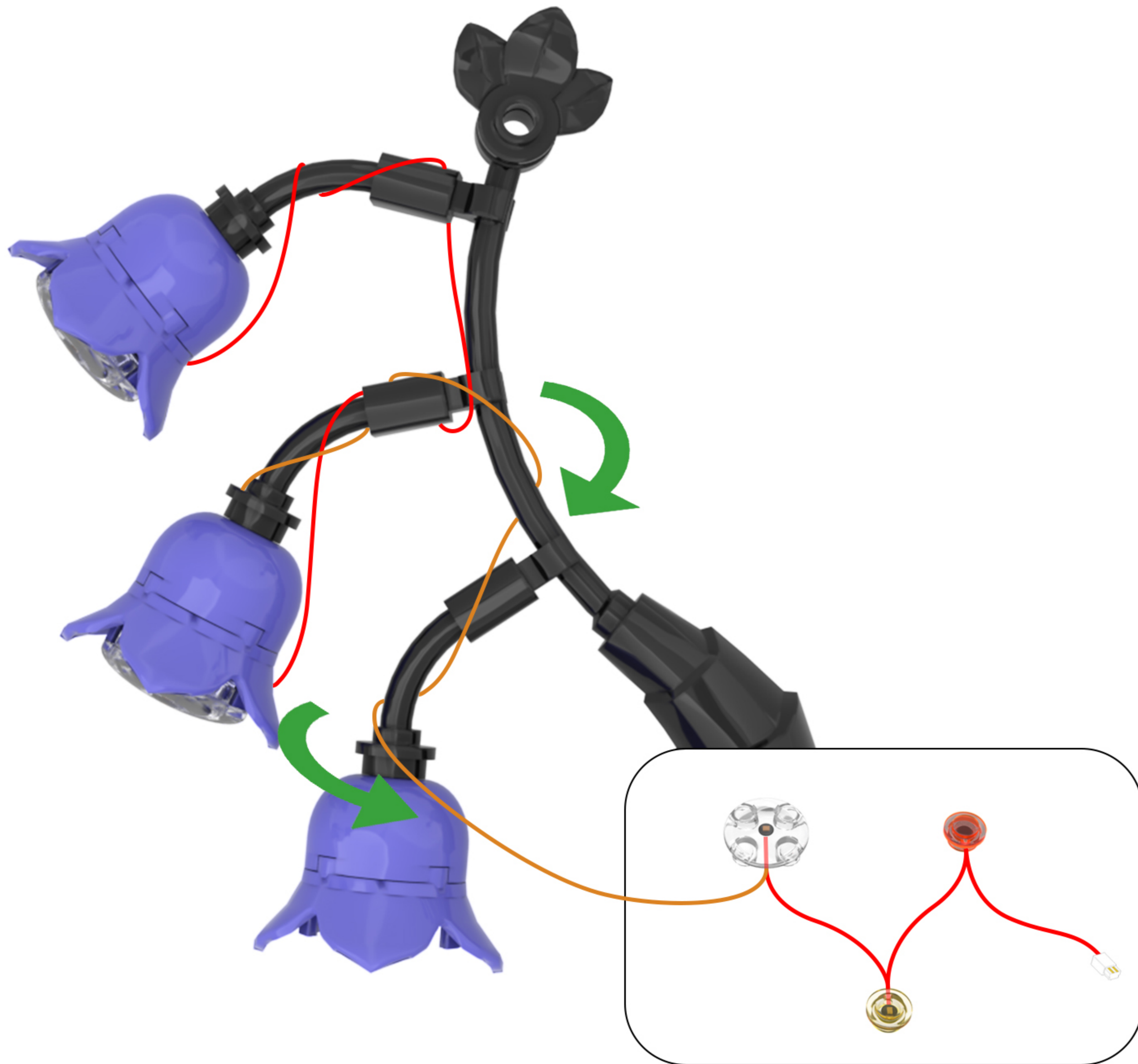

12

EN: Attach the lights from the string to the building blocks.

DE: Befestigen Sie die Lichter der Lichterkette an den Bausteinen.

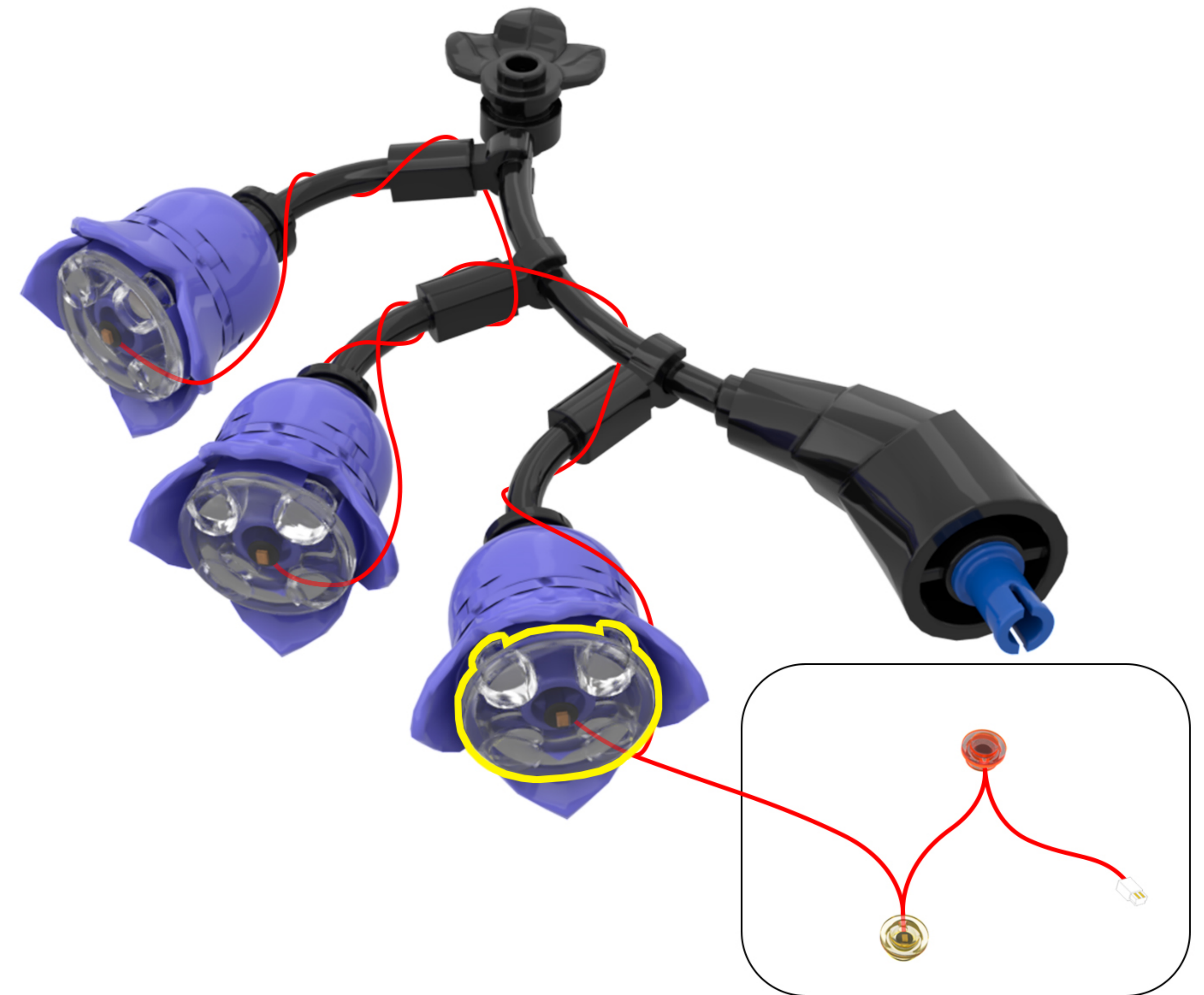

13

EN: Wrap the light cord back around the building block.

DE: Wickle das Lichtkabel wieder um den Baustein.

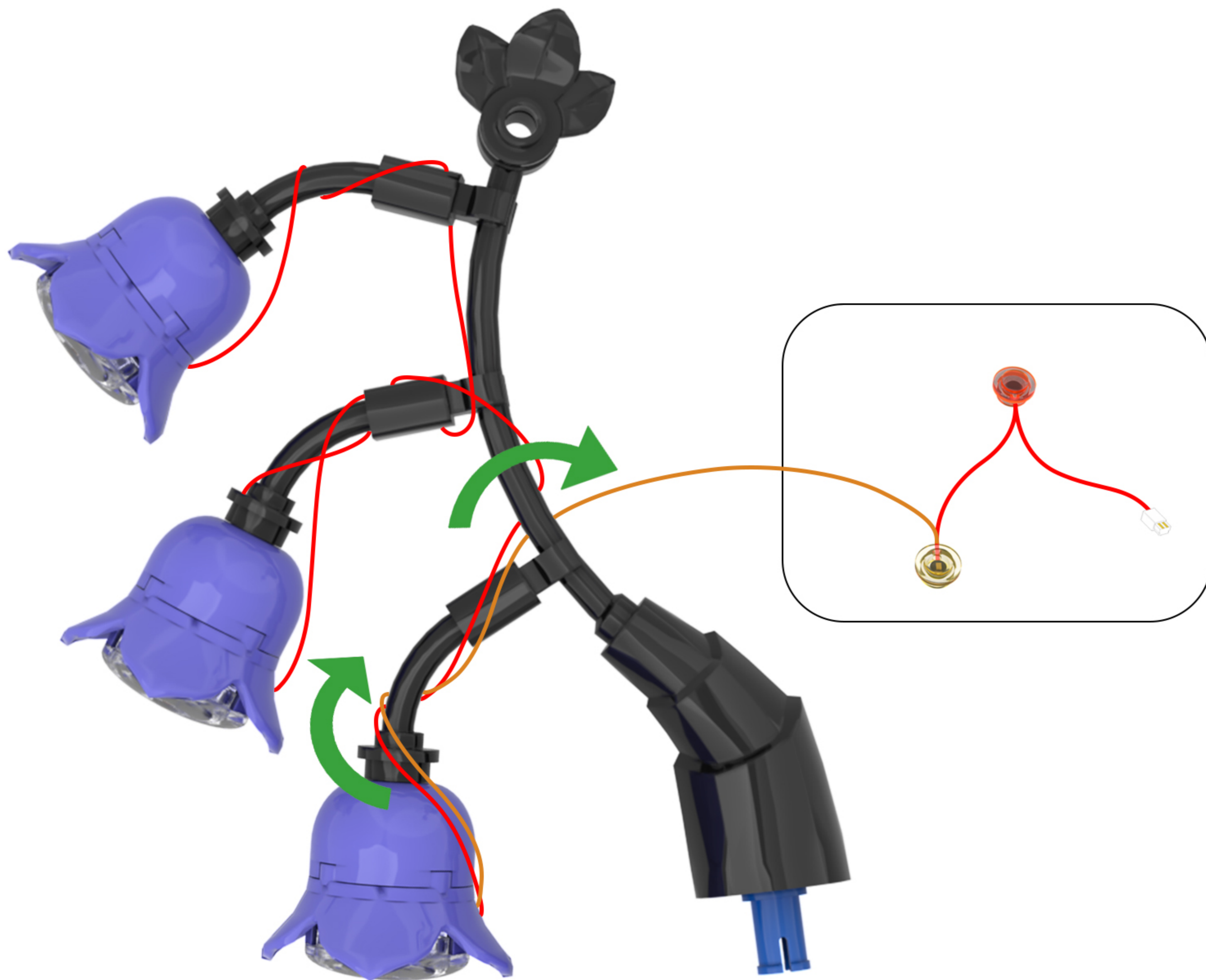

14

EN: Restore the building blocks.

DE: Stellen Sie die Bausteine wieder her.

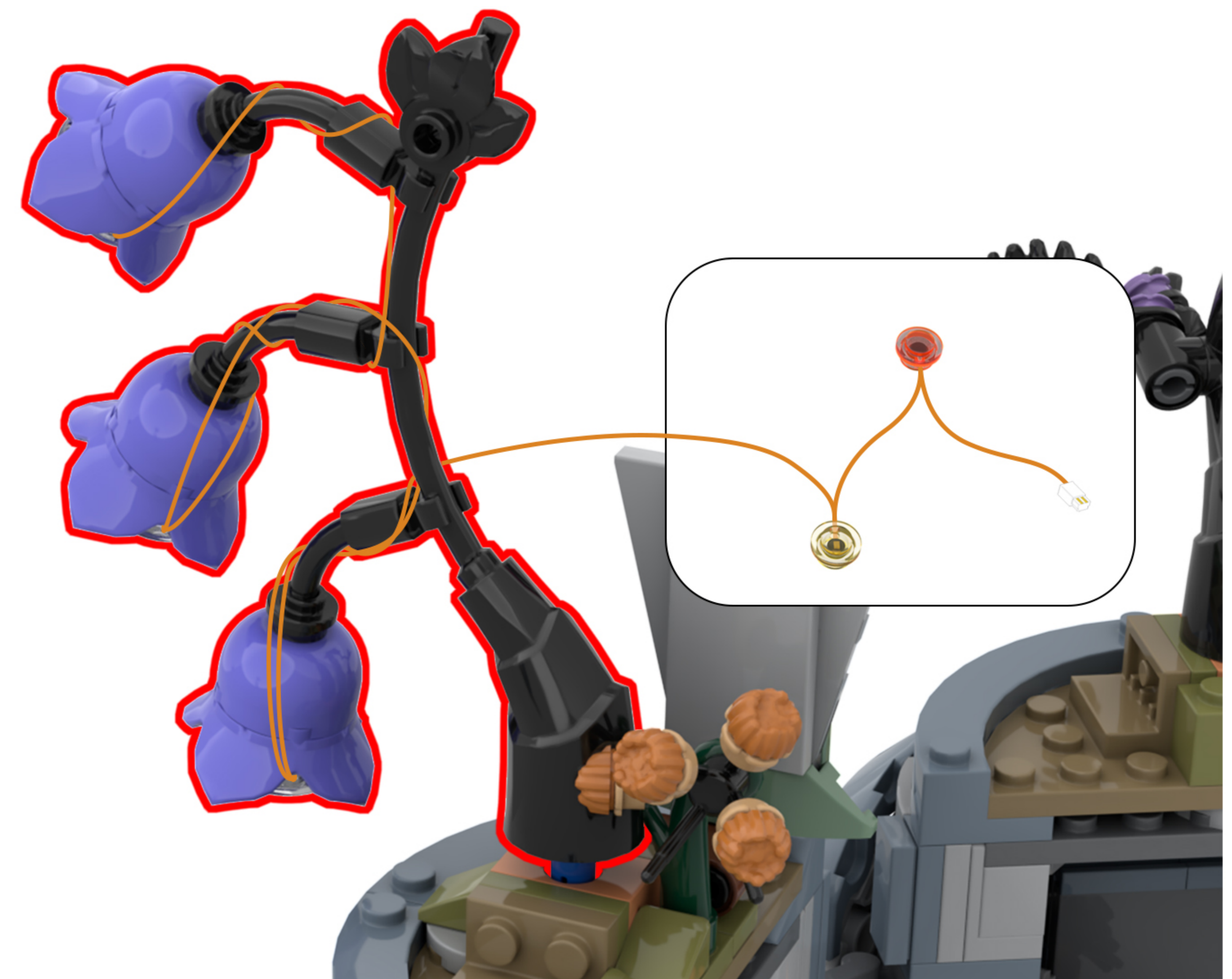

Note: When reassembling, leave a little space and do not push the blocks all the way in.

15

EN: Place the light cord underneath the building block.

DE: Lege das Lichtkabel unter den Baustein.

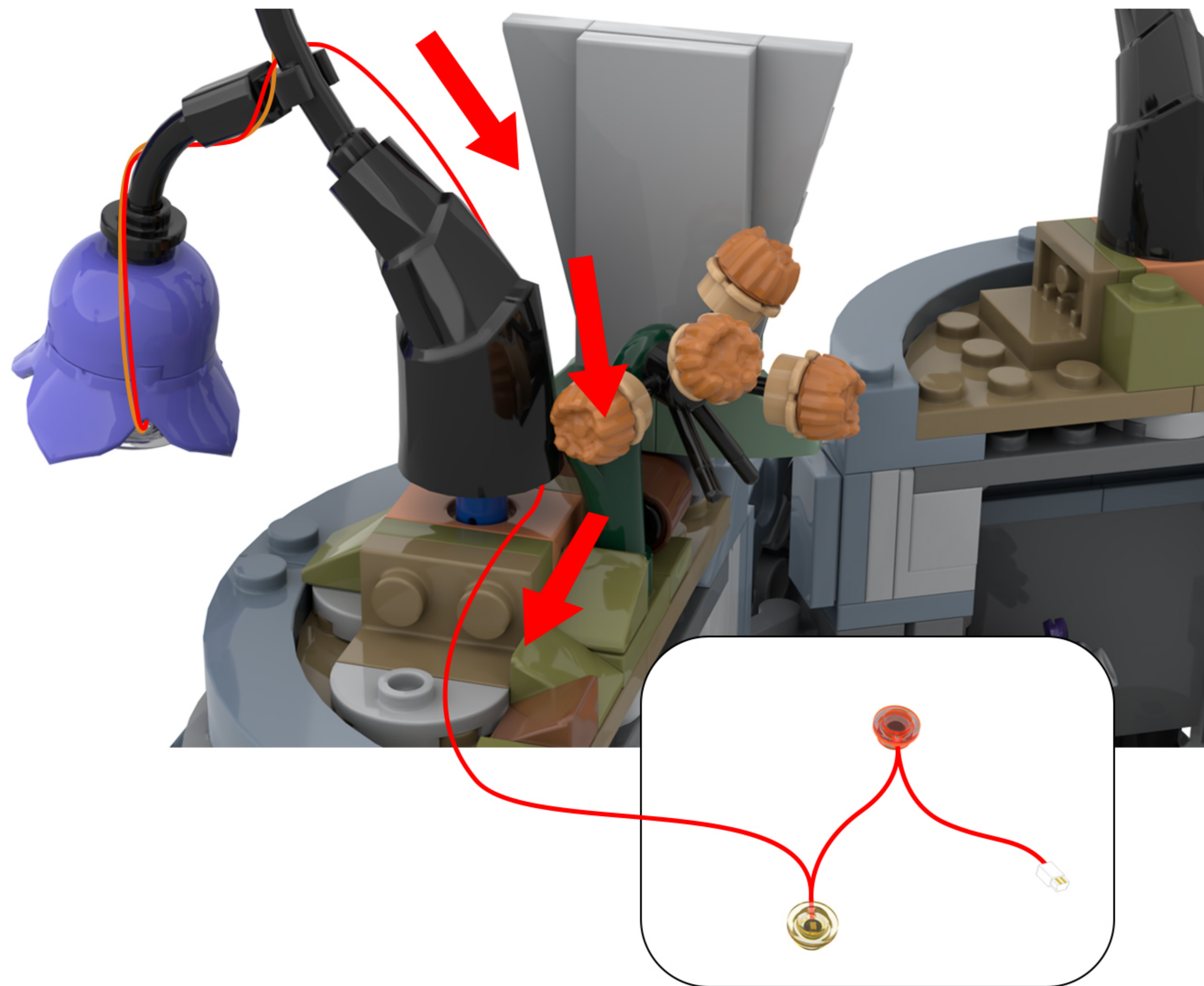

16

EN: Reassemble the building blocks and secure the light cord.

DE: Setzen Sie die Bausteine wieder zusammen und befestigen Sie das Lichtkabel.

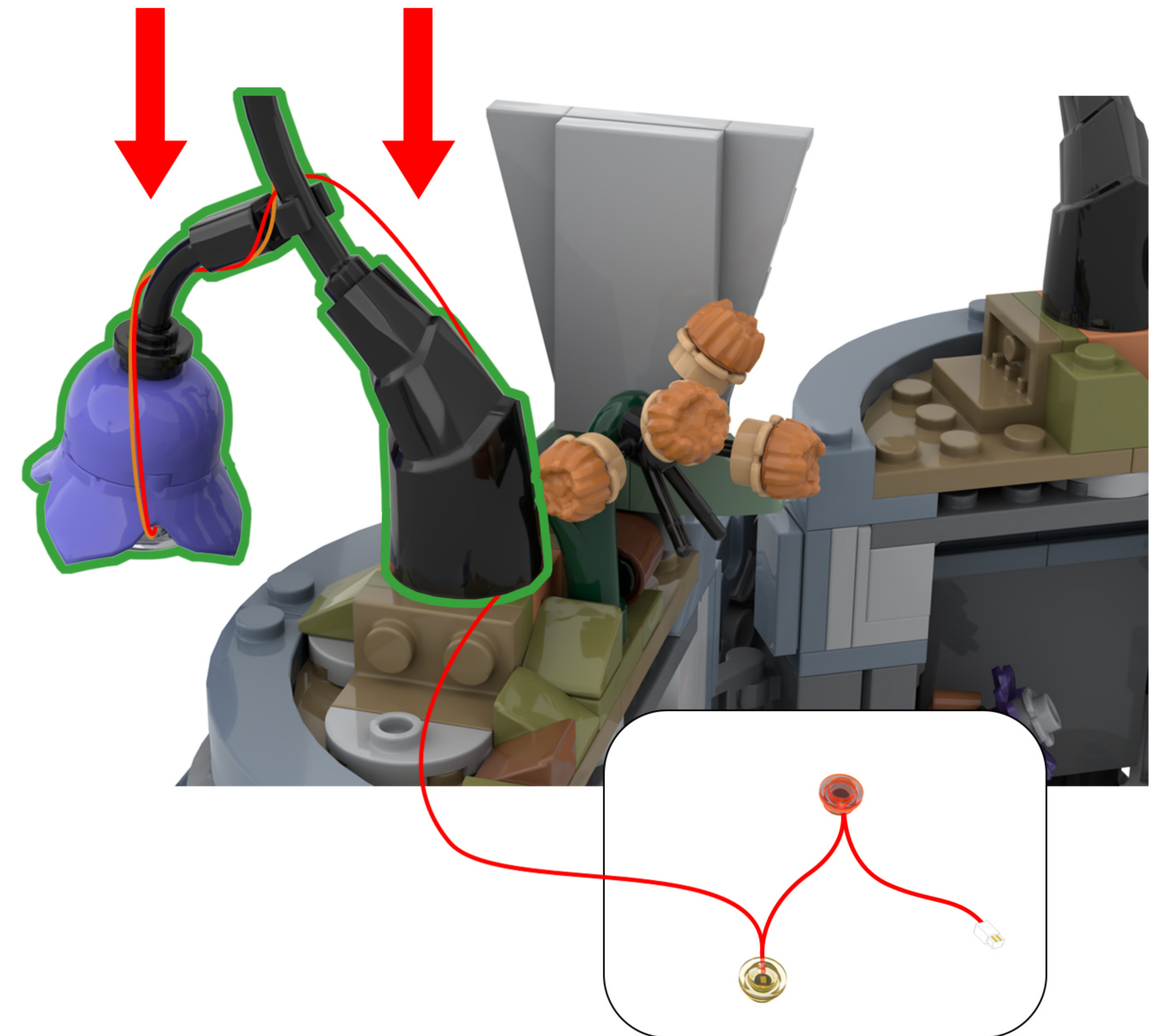

17

EN: Attach the lights from the string to the building blocks.

DE: Befestigen Sie die Lichter der Lichterkette an den Bausteinen.

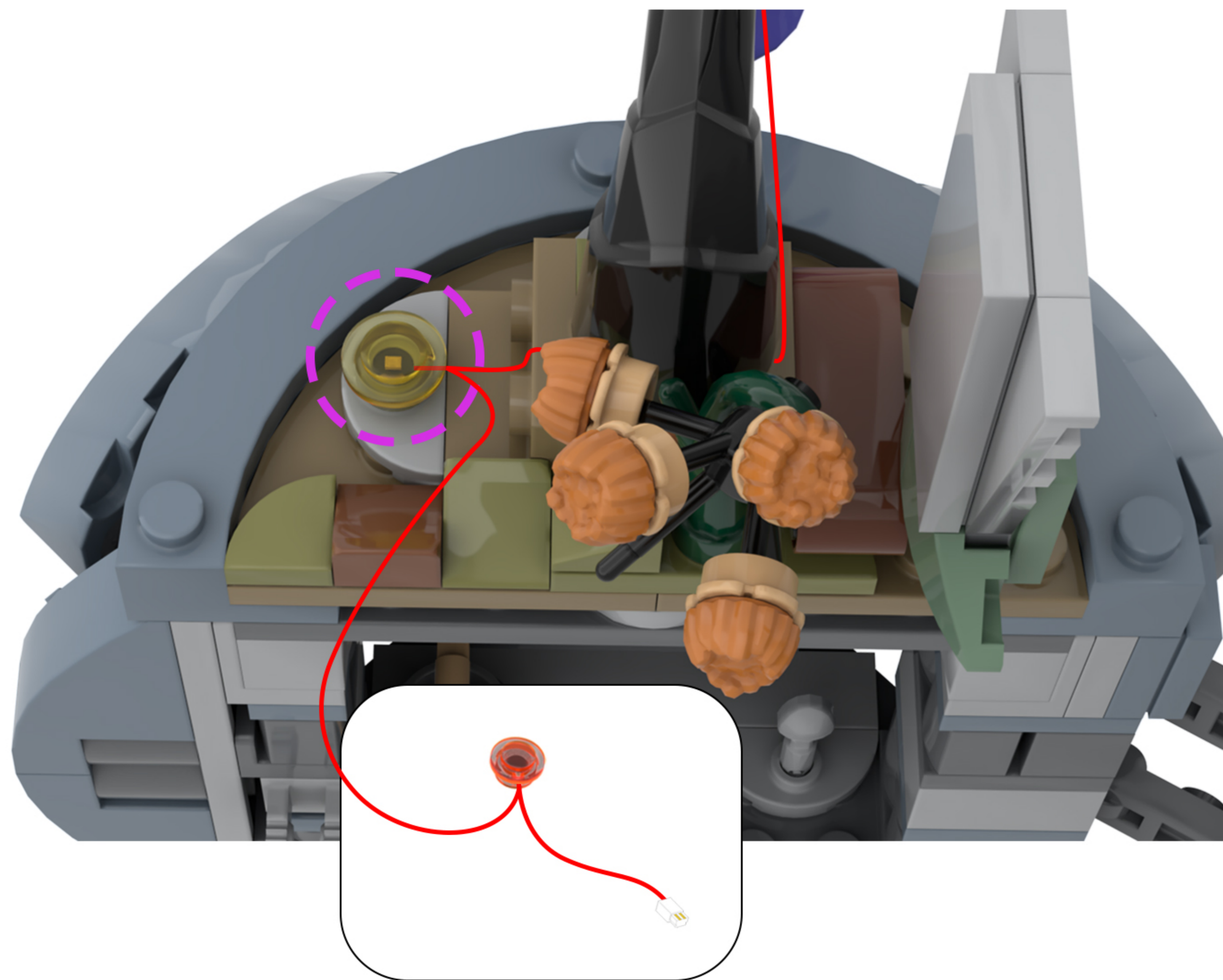

18

EN: Take out the disassembled building blocks and reassemble them.

DE: Nehmen Sie die zerlegten Bausteine heraus und setzen Sie sie wieder zusammen.

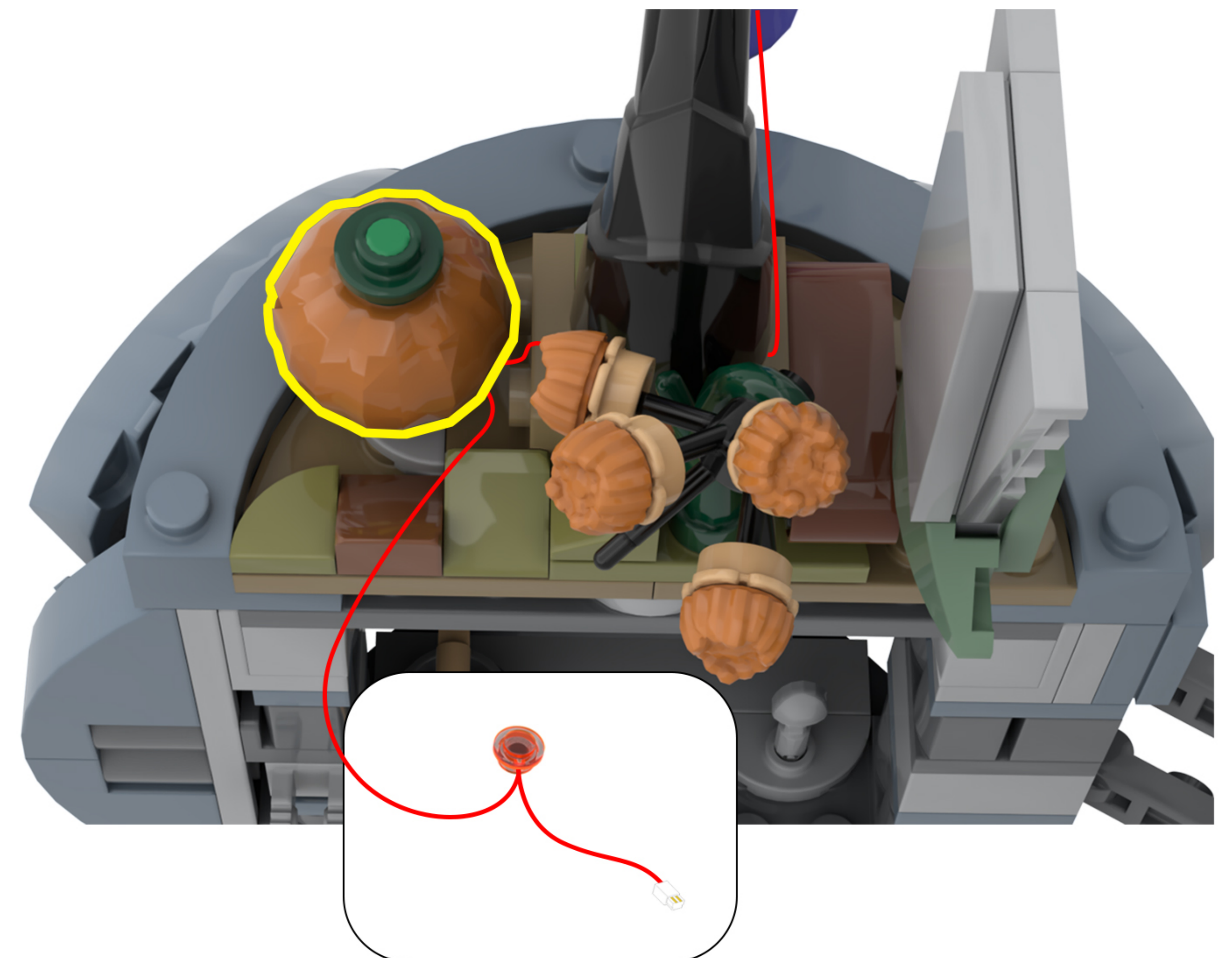

19

EN: Split as shown in the figure.

DE: Wie in der Abbildung gezeigt, teilen Sie es auf.

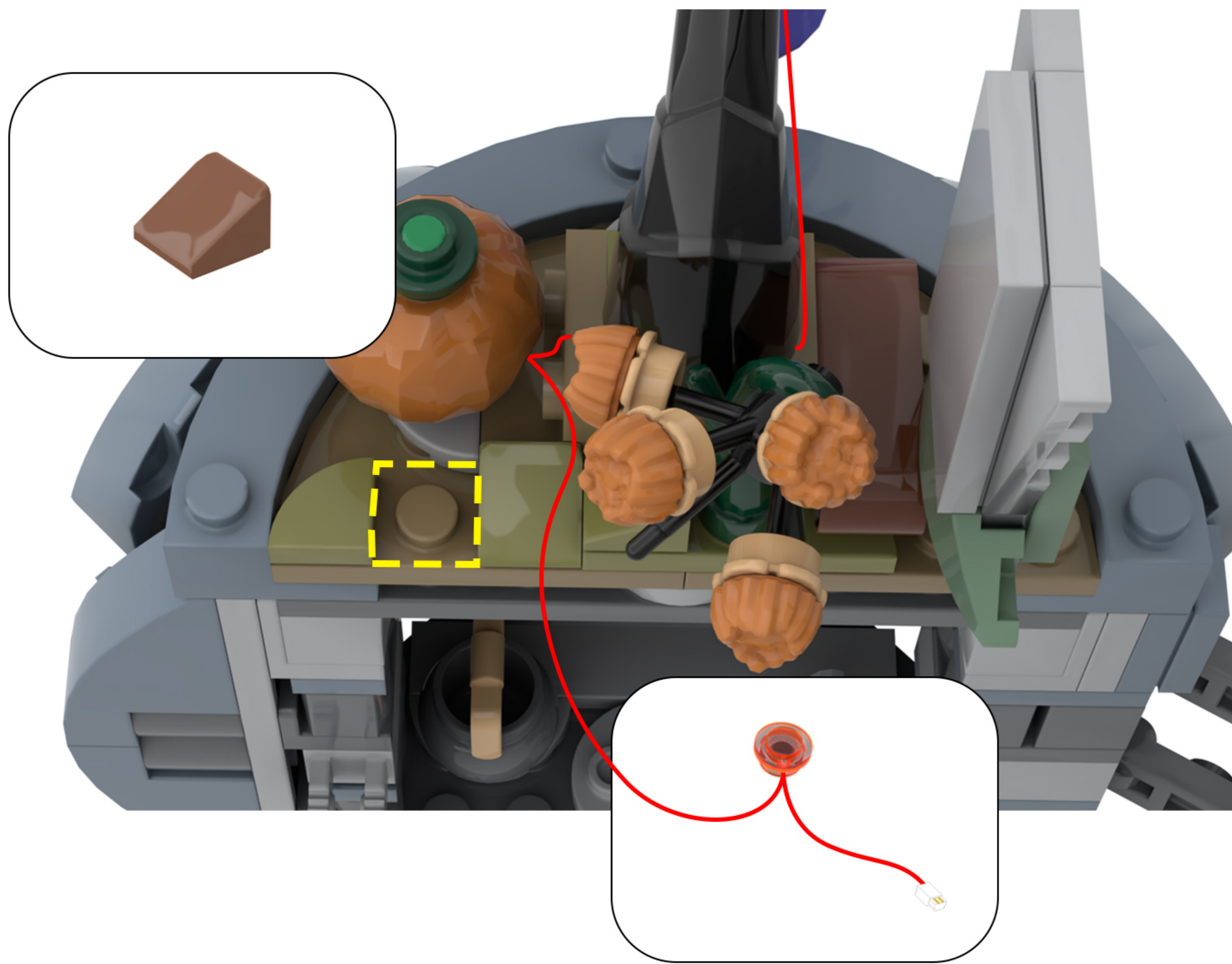

20

EN: Arrange the lighting lines according to the diagram.

DE: Ordnen Sie die Beleuchtungslinien gemäß der Abbildung an.

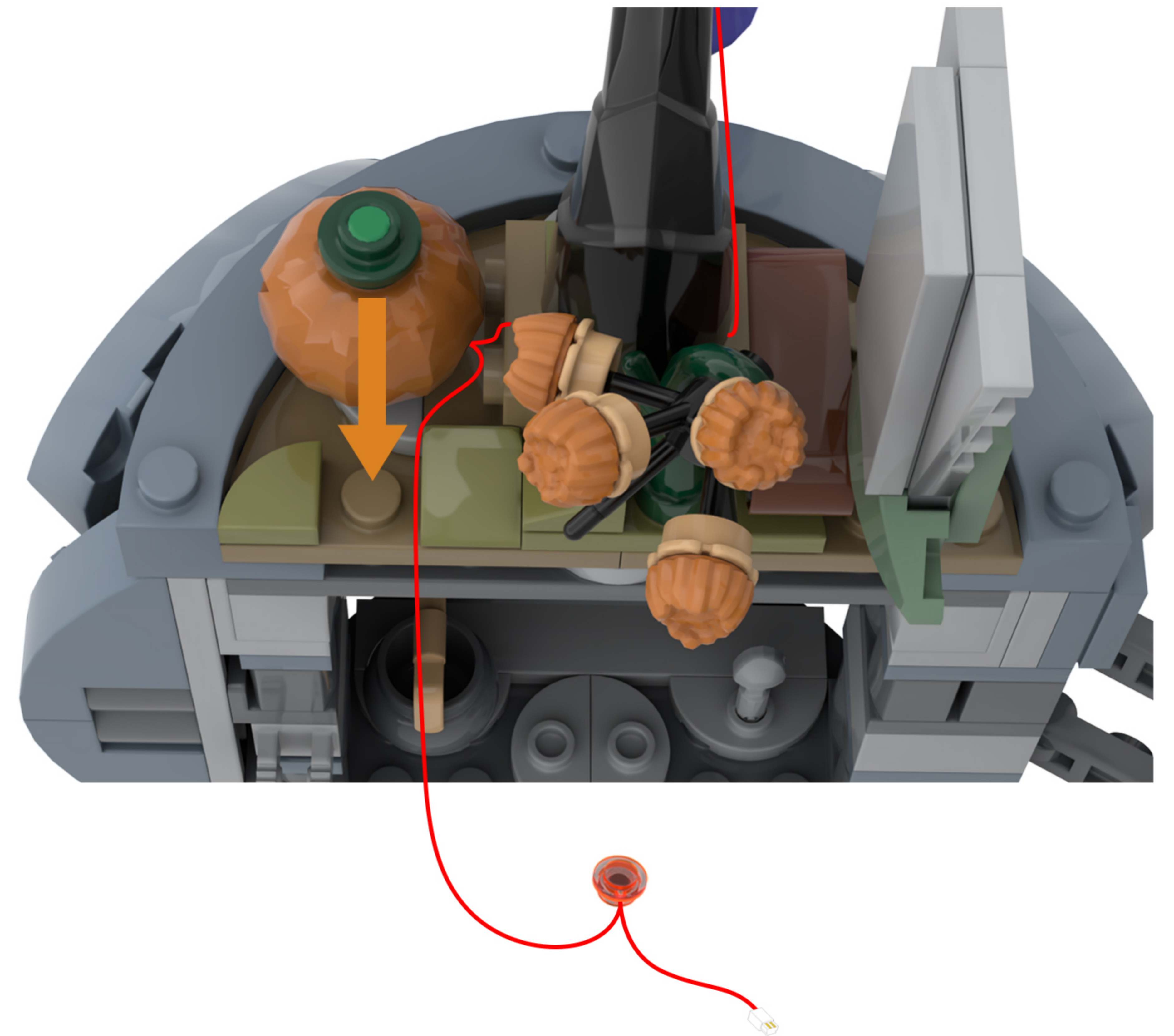

21

EN: Take out the disassembled building blocks, reassemble them, and secure the light cord.

DE: Nehmen Sie die zerlegten Bausteine heraus, setzen Sie sie wieder zusammen und befestigen Sie das Lichtkabel.



x1

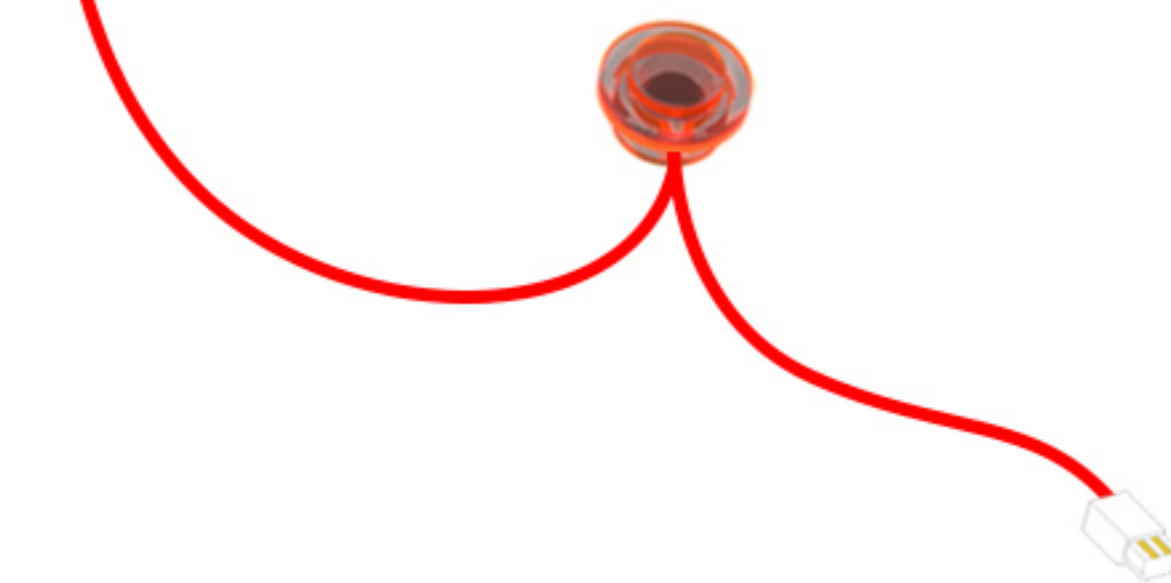
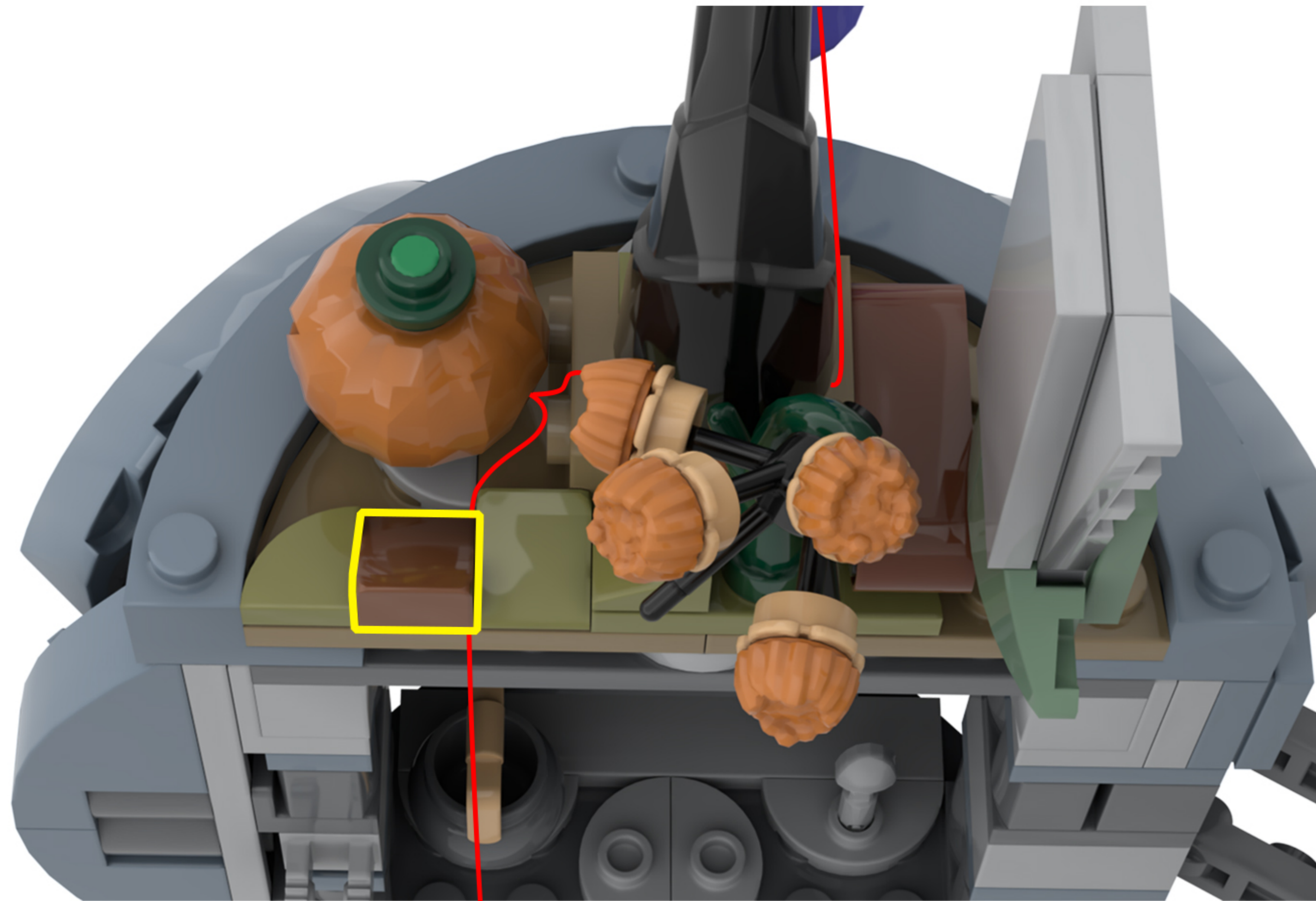

22

EN: Find the lights in the string of lights.

DE: Finde die Lichter in der Lichterkette.

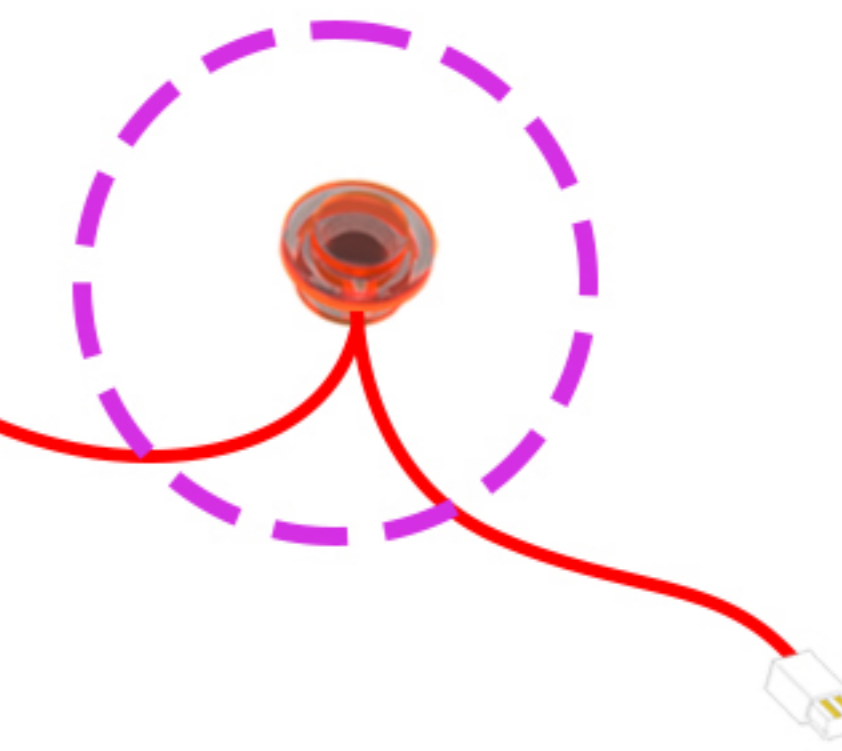
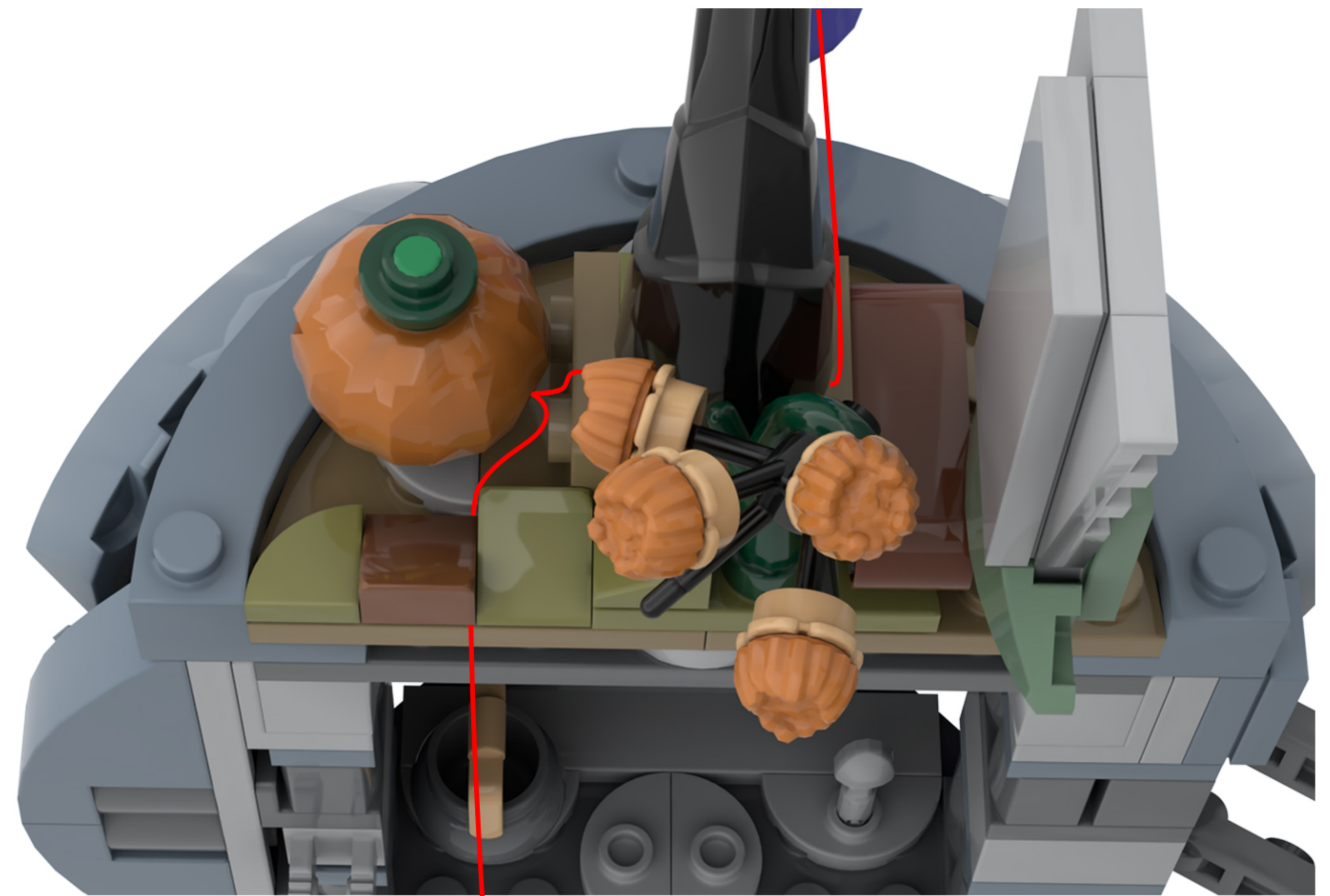

23

EN: Attach the lights from the string to the building blocks.

DE: Befestigen Sie die Lichter der Lichterkette an den Bausteinen.

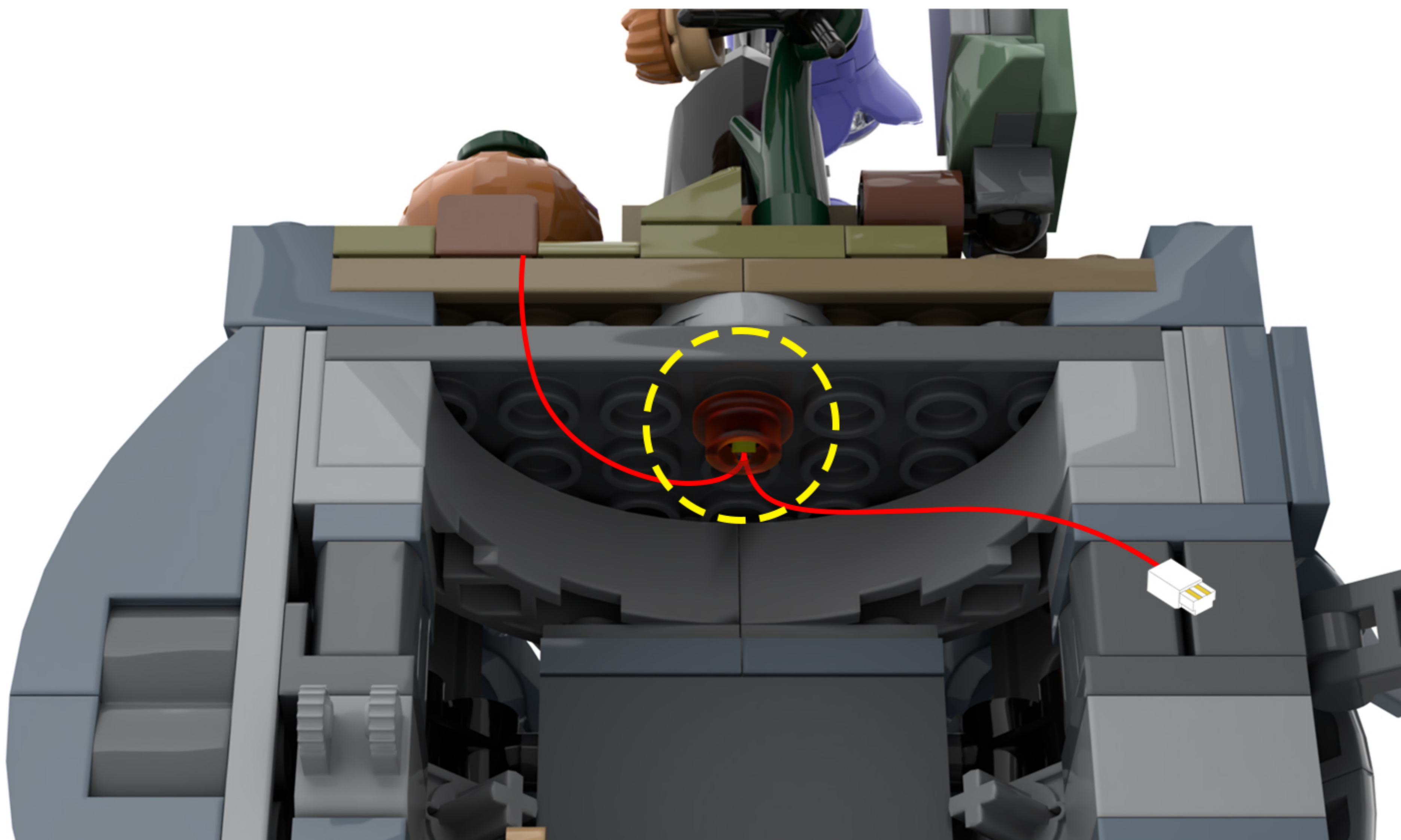

24

EN: Adjust your perspective.

DE: Ändern Sie Ihre Perspektive.



27

EN: Take the string of lights out of Bag 1, untie the zip tie, and locate the decorative lights on the string.

DE: Nimm die Lichterkette aus Beutel 1, löse den Kabelbinder und suche die dekorativen Lichter an der Kette.

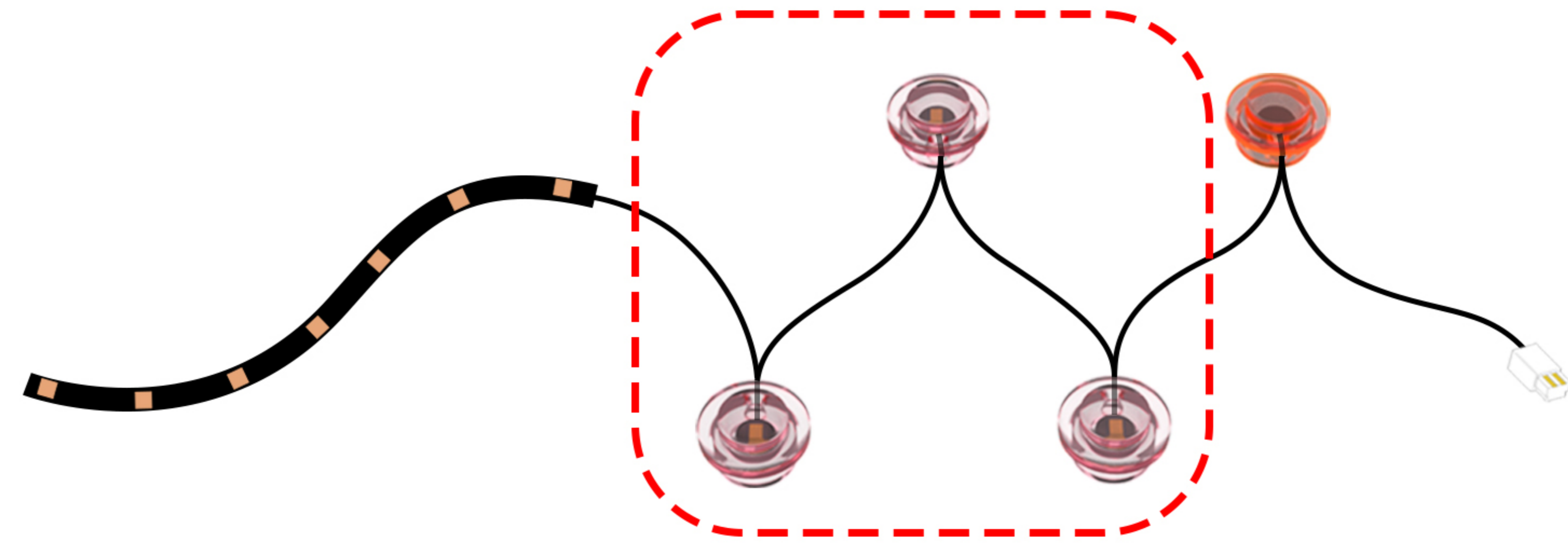
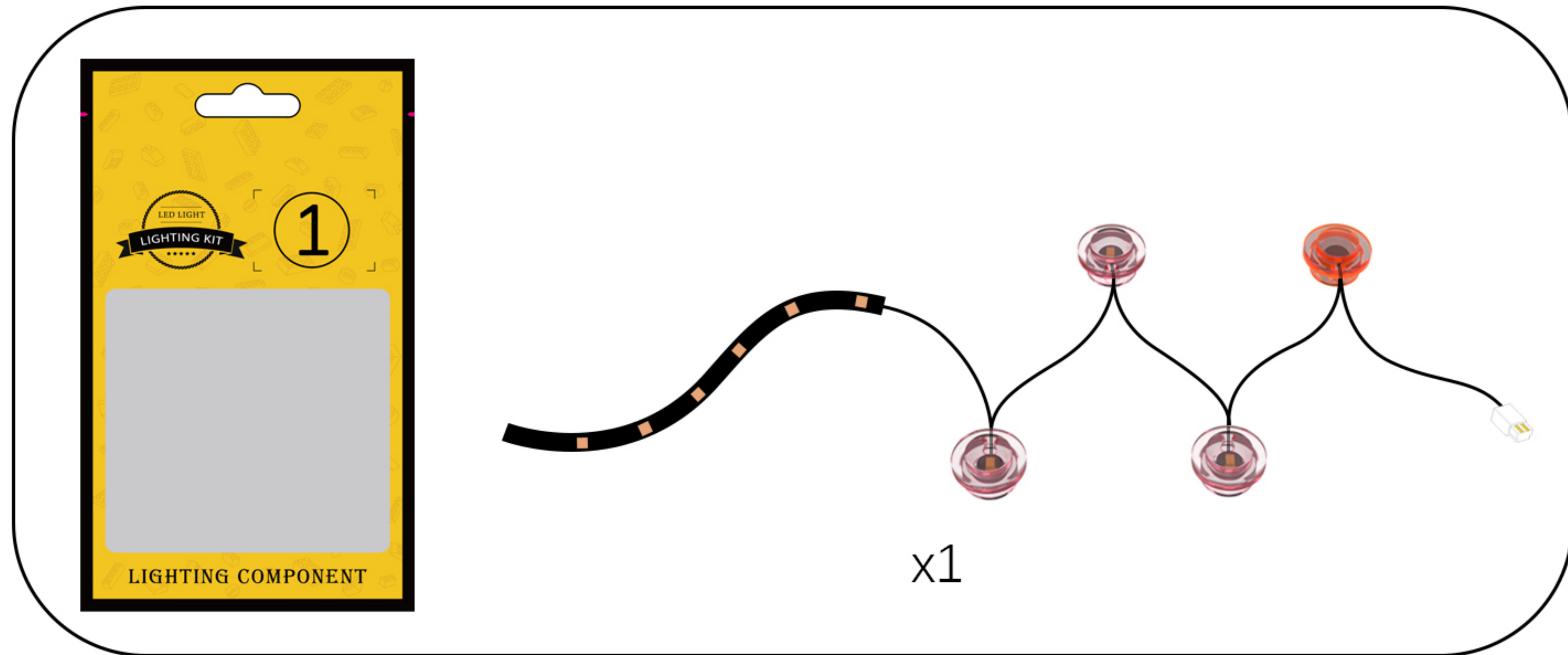

28

EN: Take the disassembled building blocks and attach them one by one to the three lights on the string.

DE: Nimm die zerlegten Bausteine und befestige sie nacheinander an den drei Lichtern der Lichterkette.

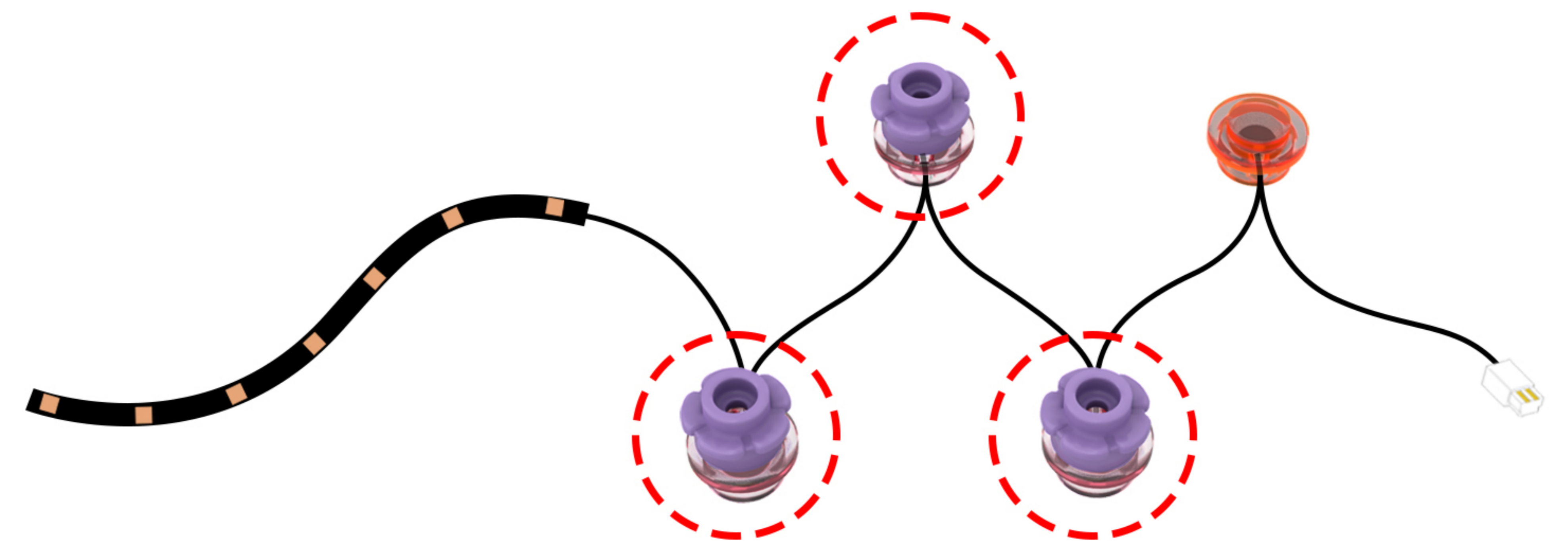
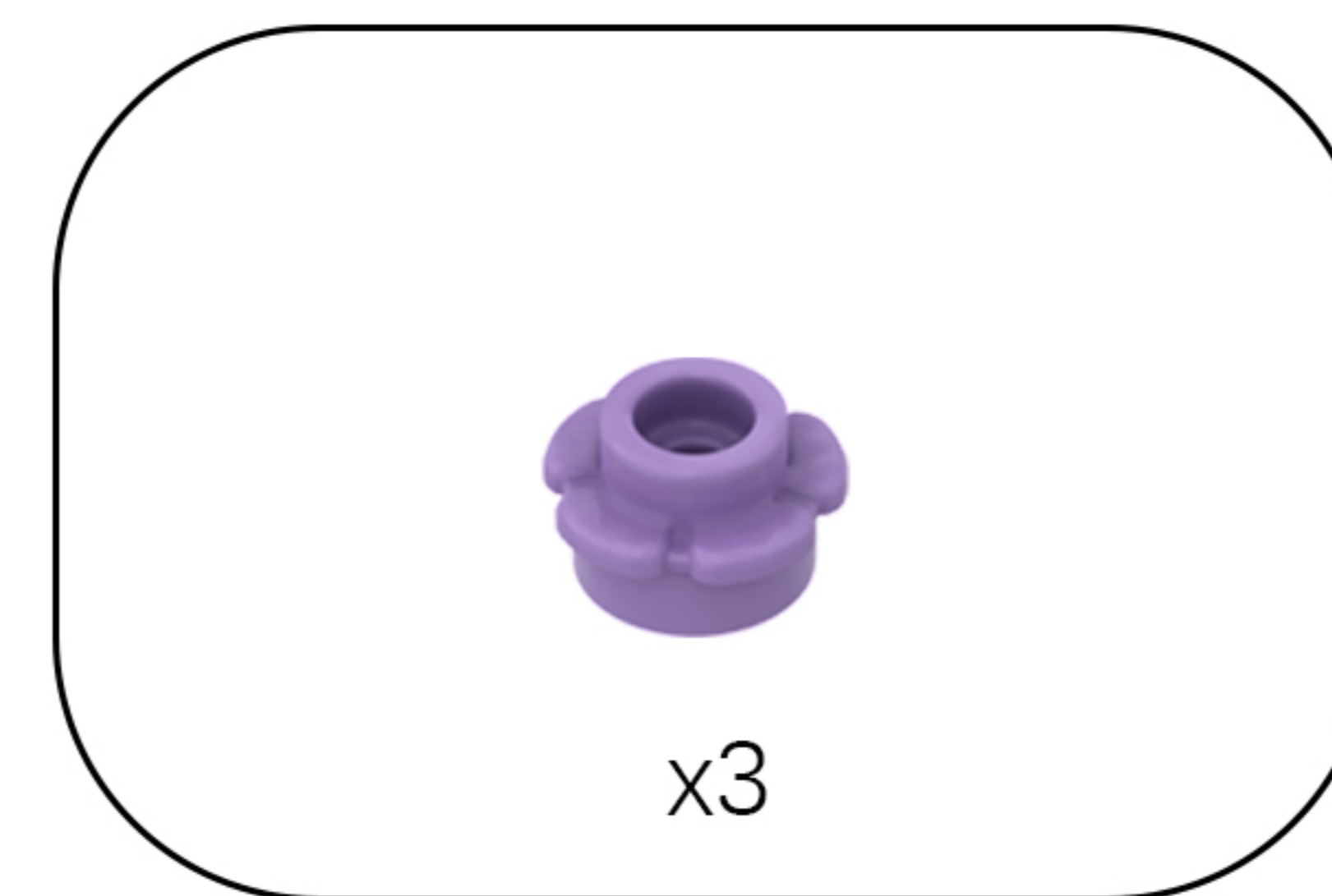

29

EN: Find the light strip on the string of lights.

DE: Finde die Leuchtdiode an der Lichterkette.

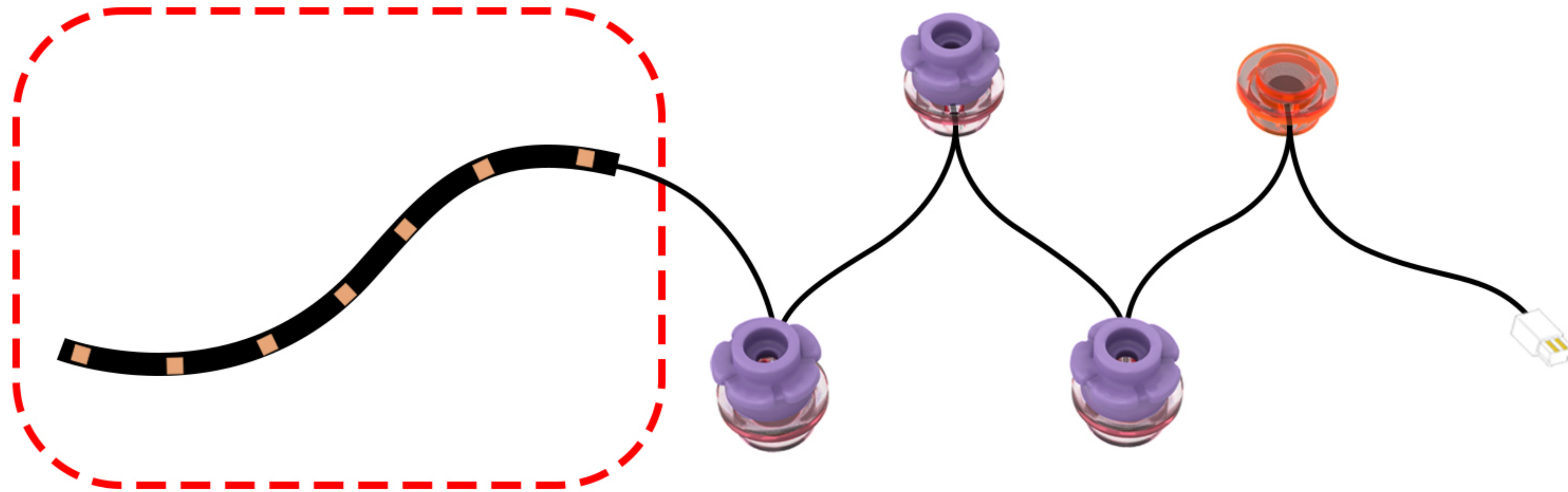

30

EN: Take the disassembled building block piece, peel off the adhesive backing from the LED strip, and wrap it around the block piece.

DE: Nehmen Sie das zerlegte Bausteinteil, ziehen Sie die Klebefolie vom LED-Streifen ab und wickeln Sie ihn um das Bausteinteil.

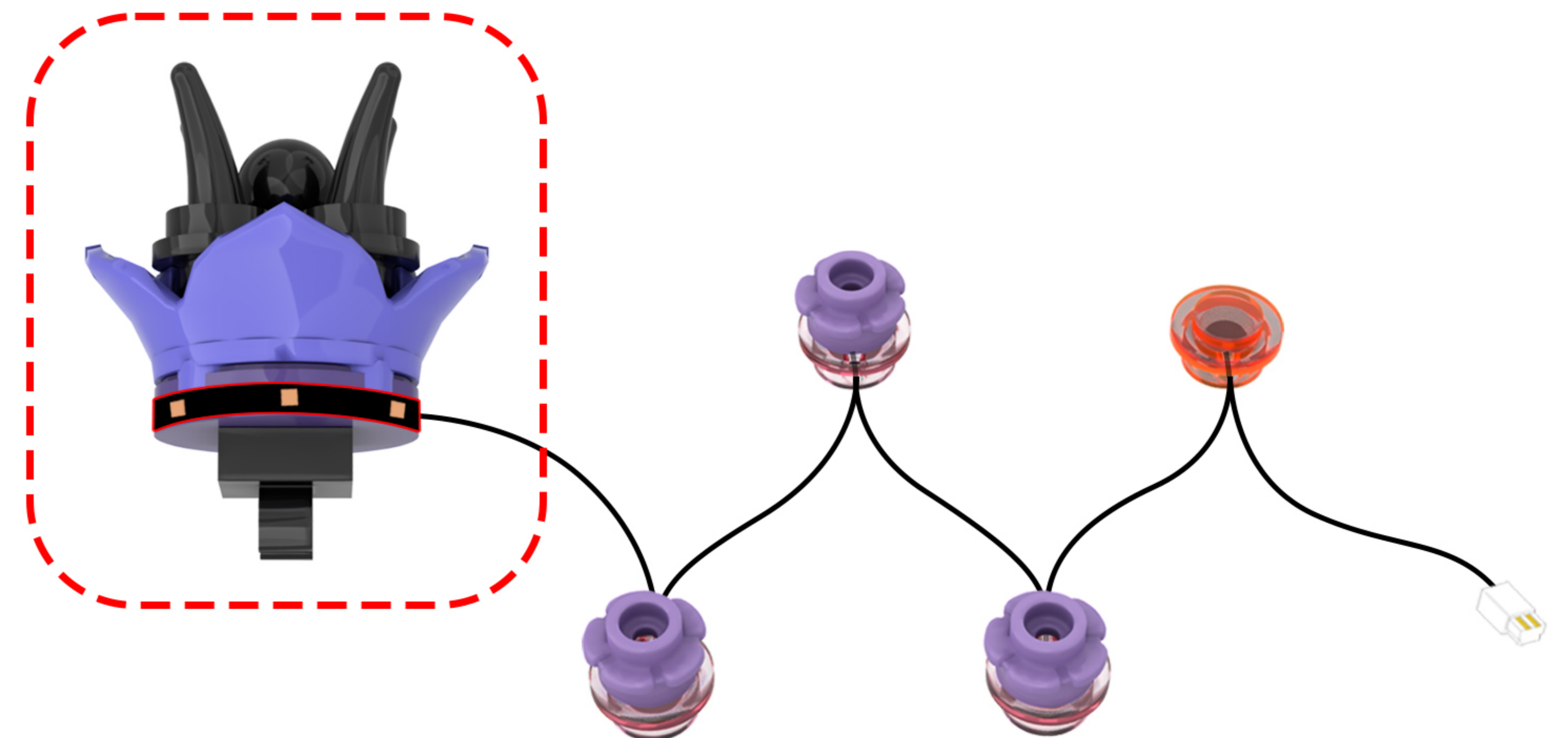
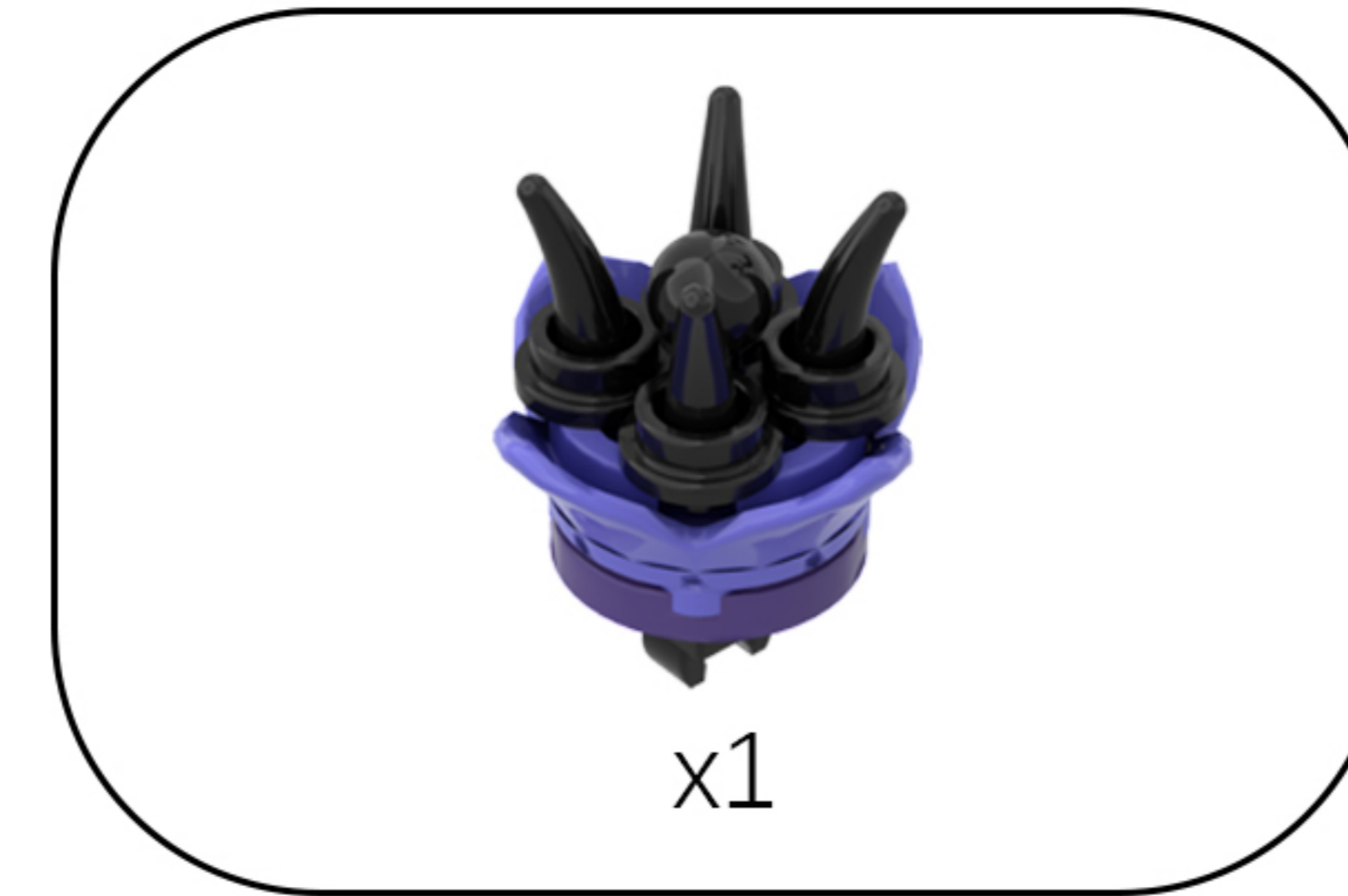

31

EN: Take out the blocks from earlier, Restore the building blocks.

DE: Nimm die Blöcke von vorhin heraus, Stellen Sie die Bausteine wieder her.

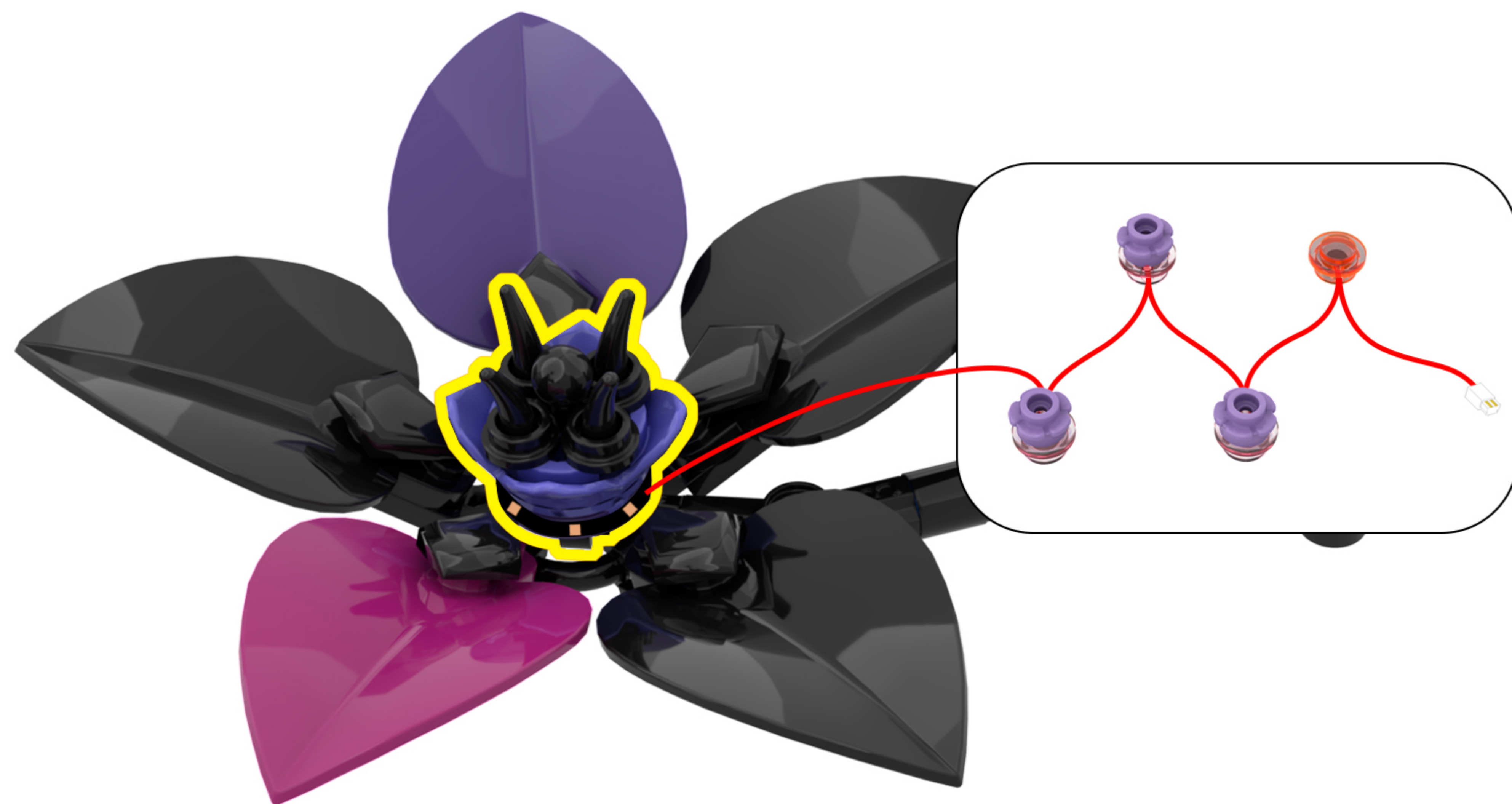
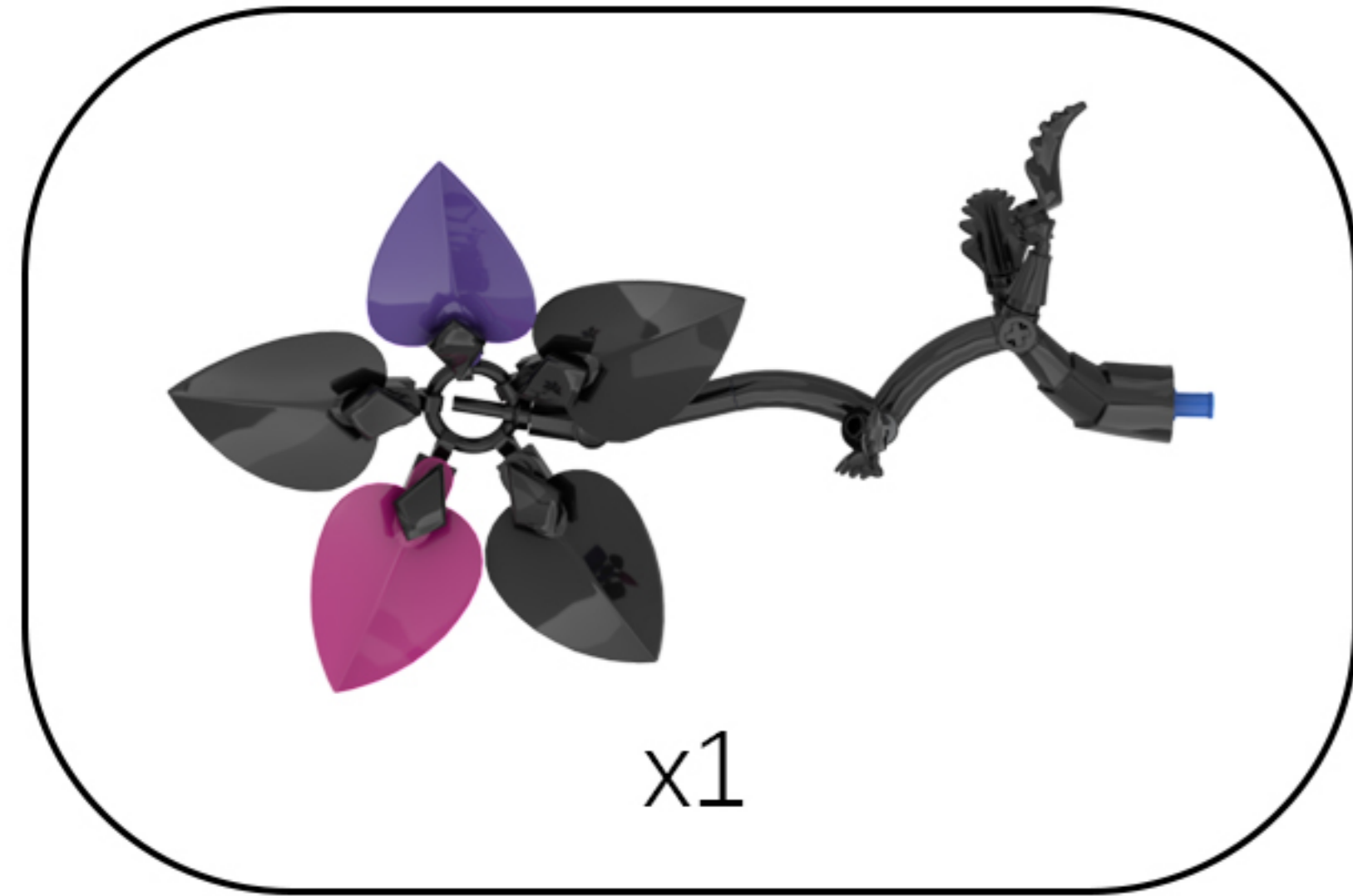

32

EN: Continue wrapping the light cord around the building block.

DE: Wickeln Sie das Lichterkabel weiter um den Baustein.

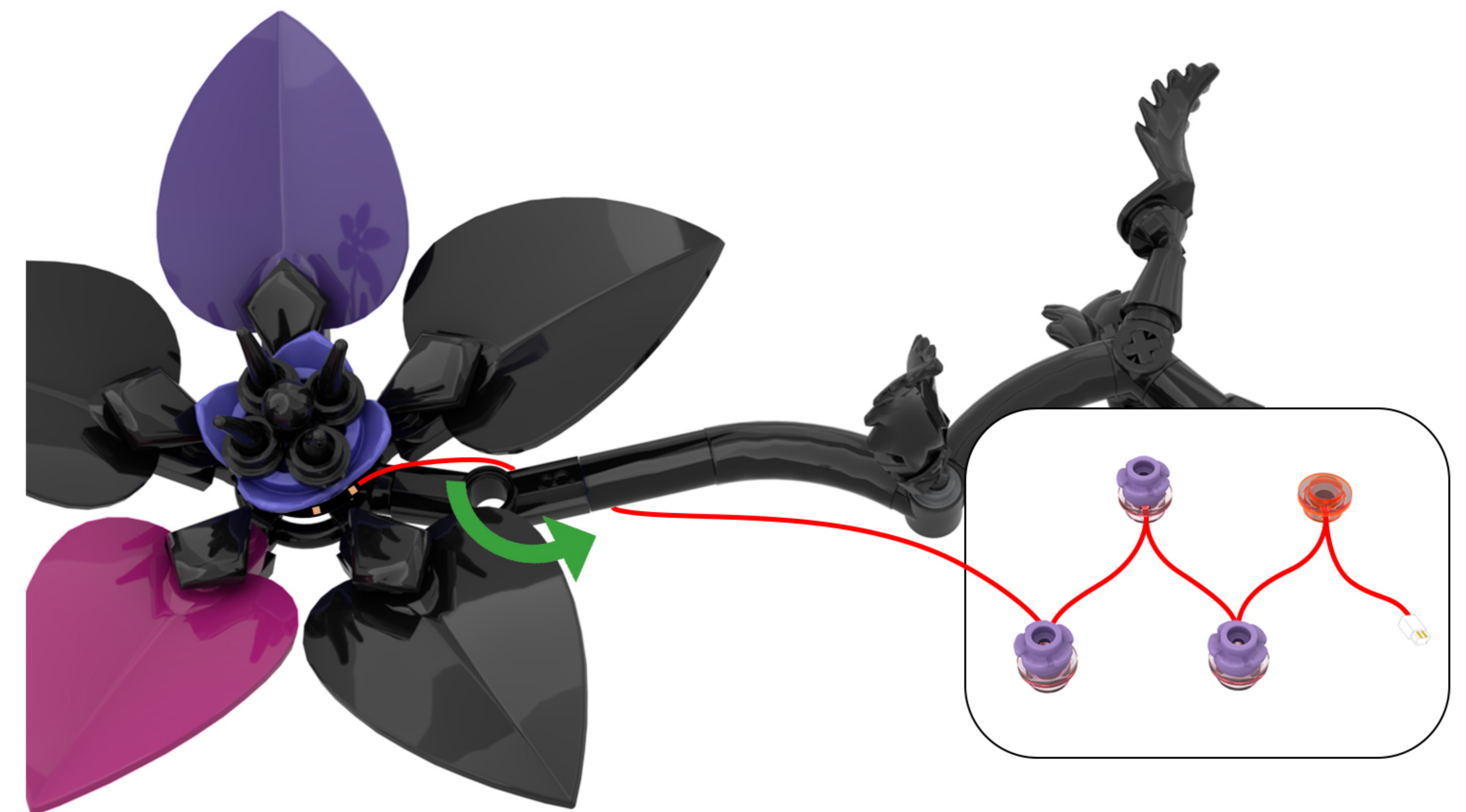

33

EN: Install the light fixture onto the building block.

DE: Installieren Sie die Leuchte auf dem Baustein.

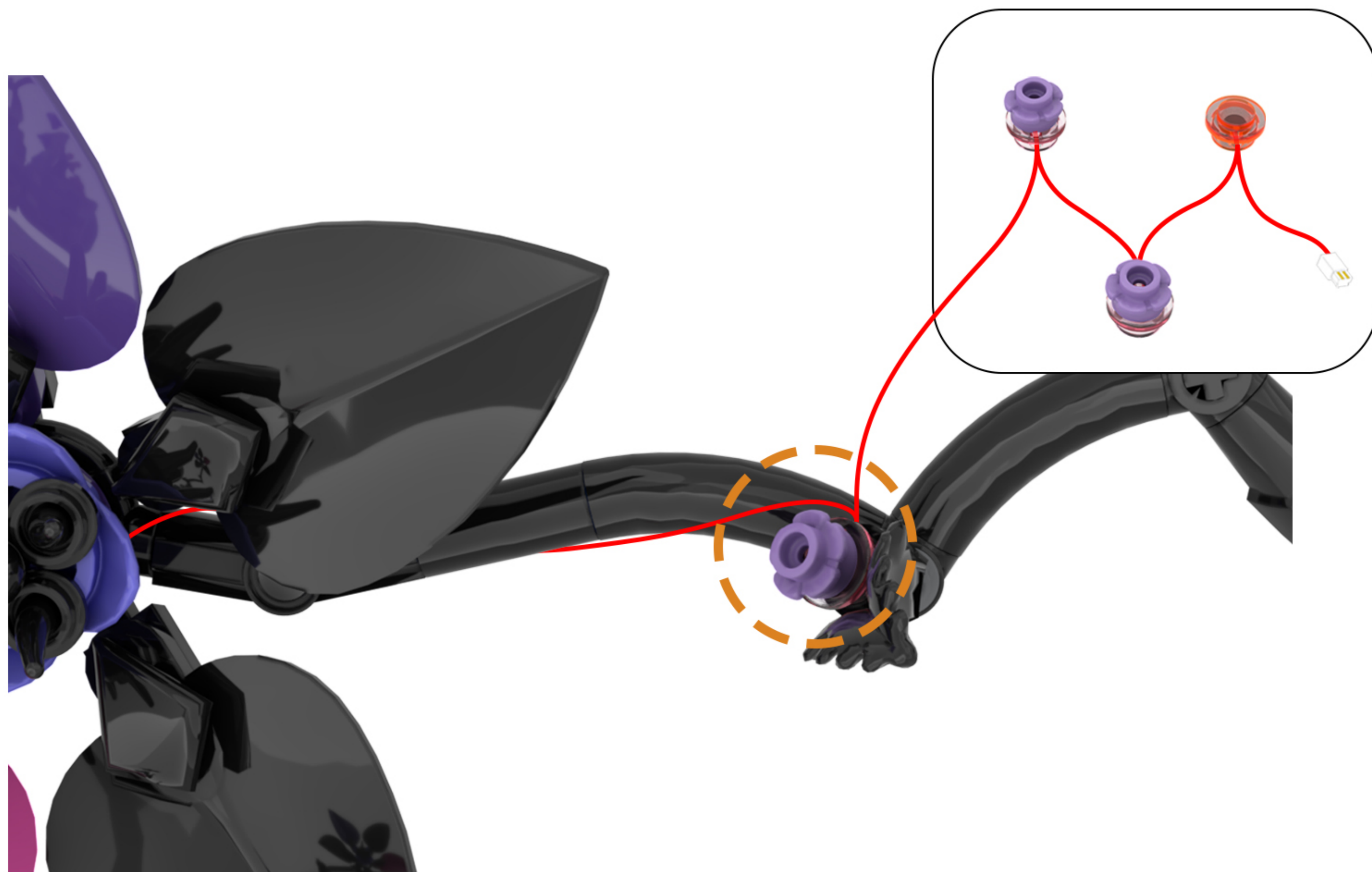

34

EN: Continue attaching the next light from the string to the building block.

DE: Befestige eine weitere Lampe der Lichterkette am Bauklotz.

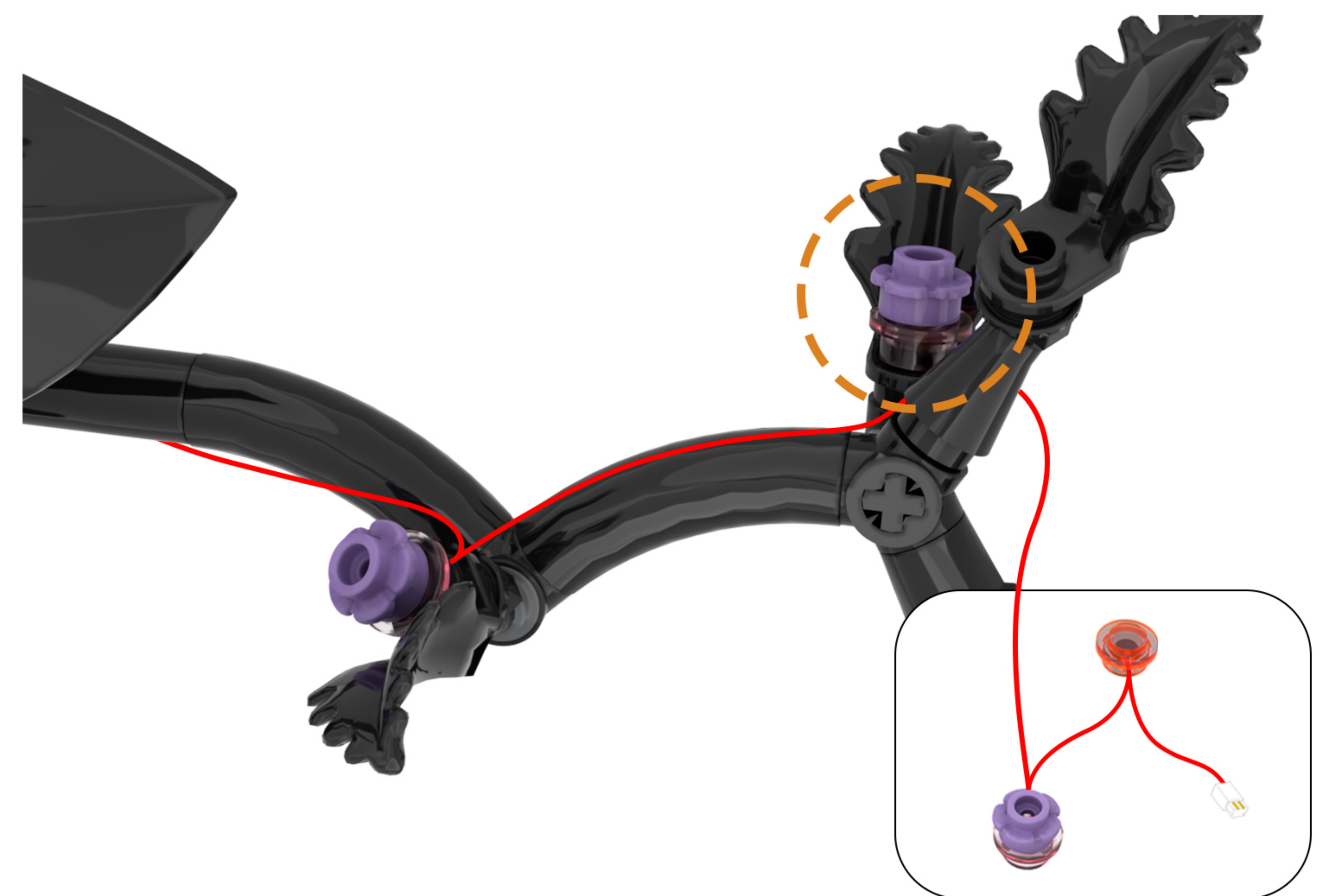

35

EN: Wrap the light cord around the building block once.

DE: Wickeln Sie das Lichtkabel einmal um den Baustein.

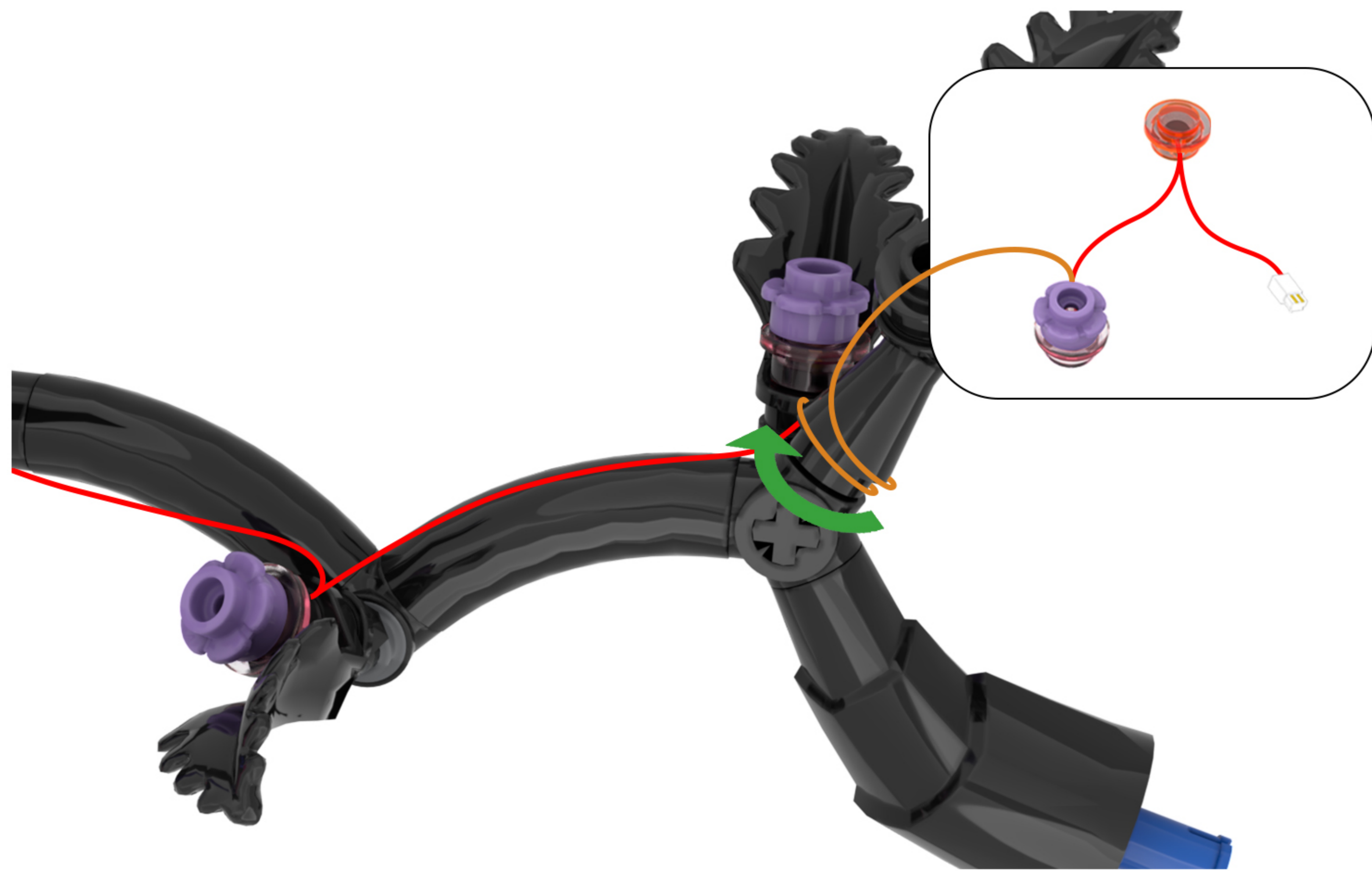

36

EN: Attach the lights from the string to the building blocks.

DE: Befestigen Sie die Lichter der Lichterkette an den Bausteinen.

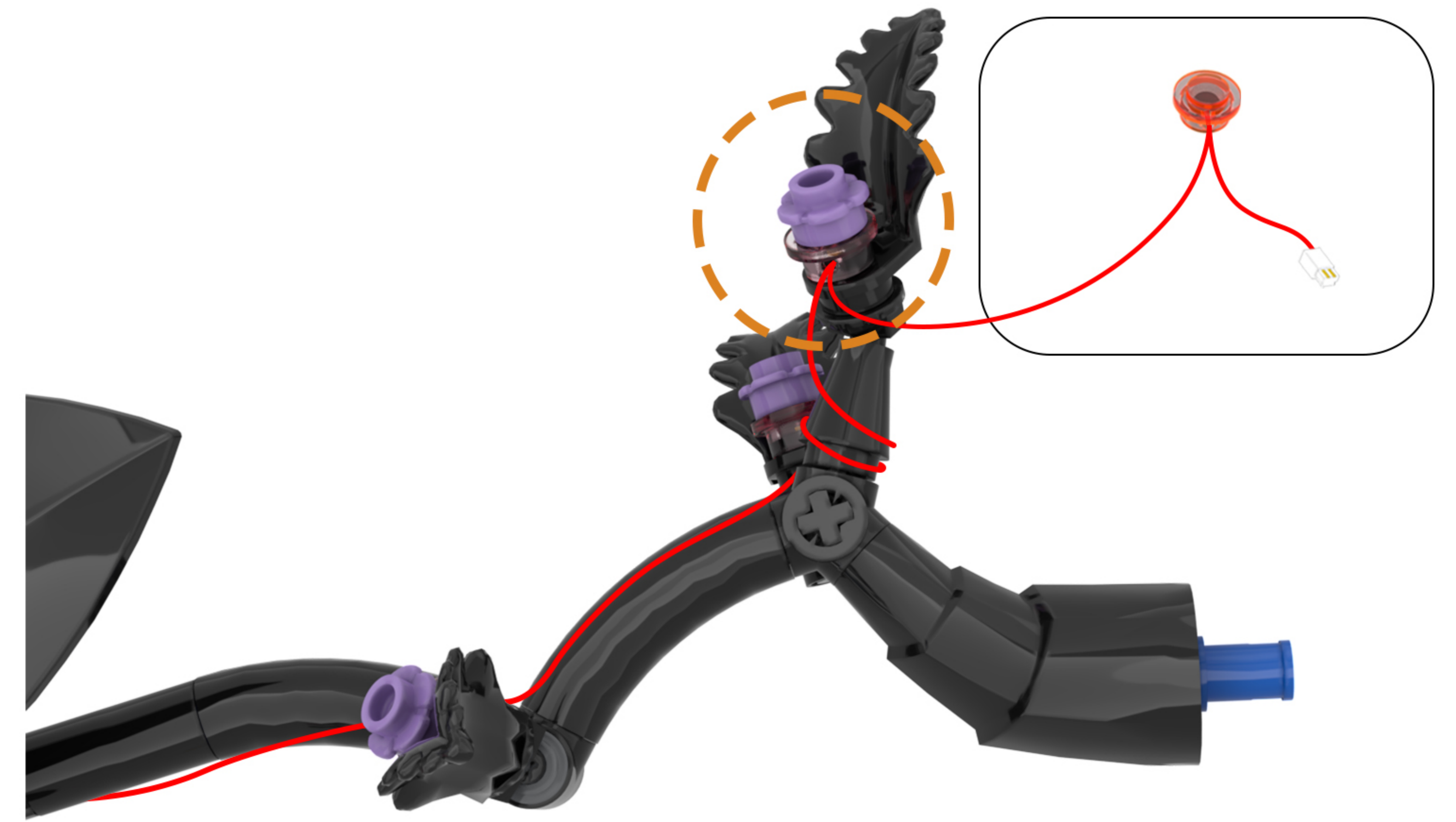

37

EN: Back to the model.

DE: Zurück zum Modell.

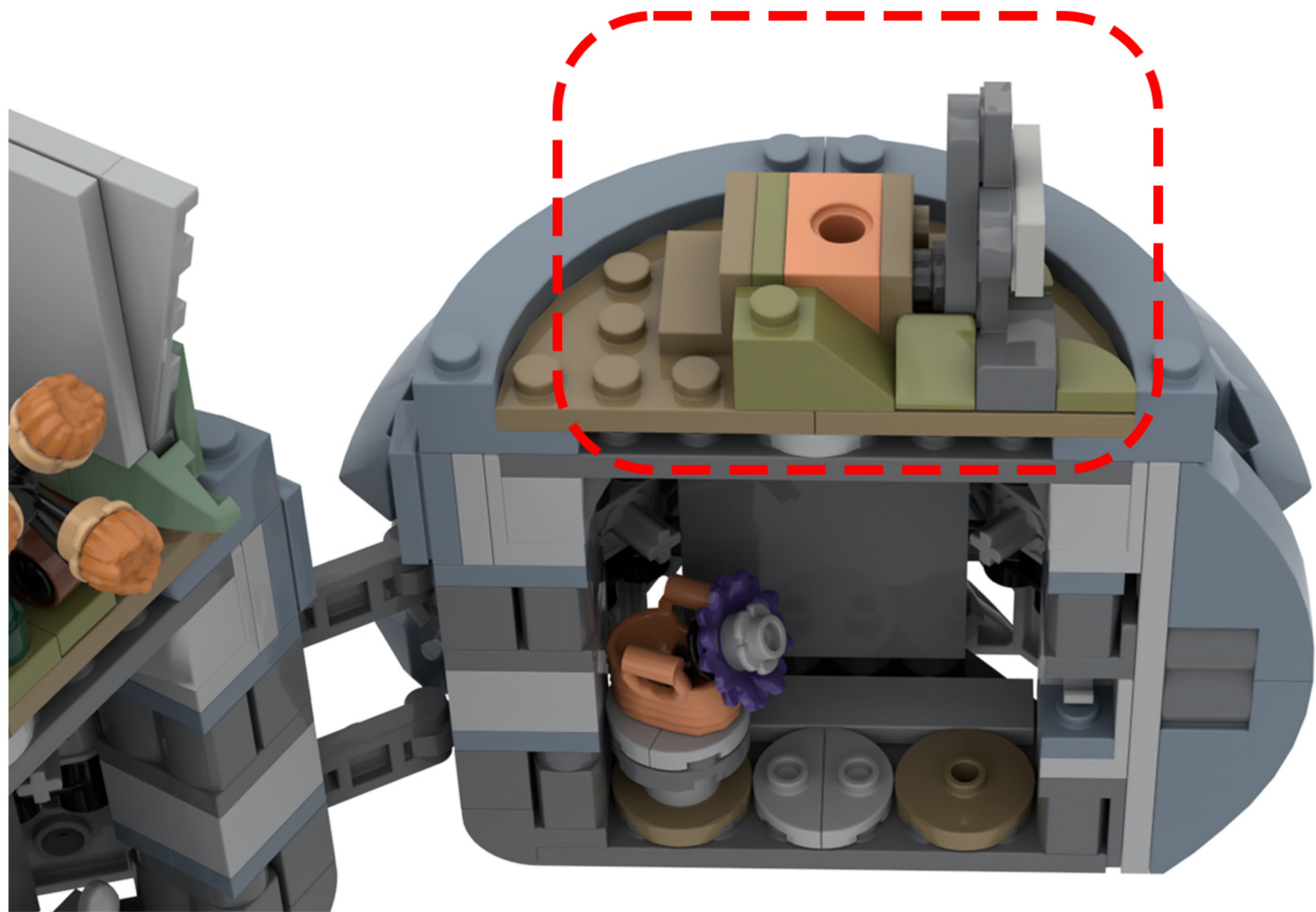

38

EN: Remove the building blocks one by one.

DE: Entfernen Sie die Bausteine nacheinander.

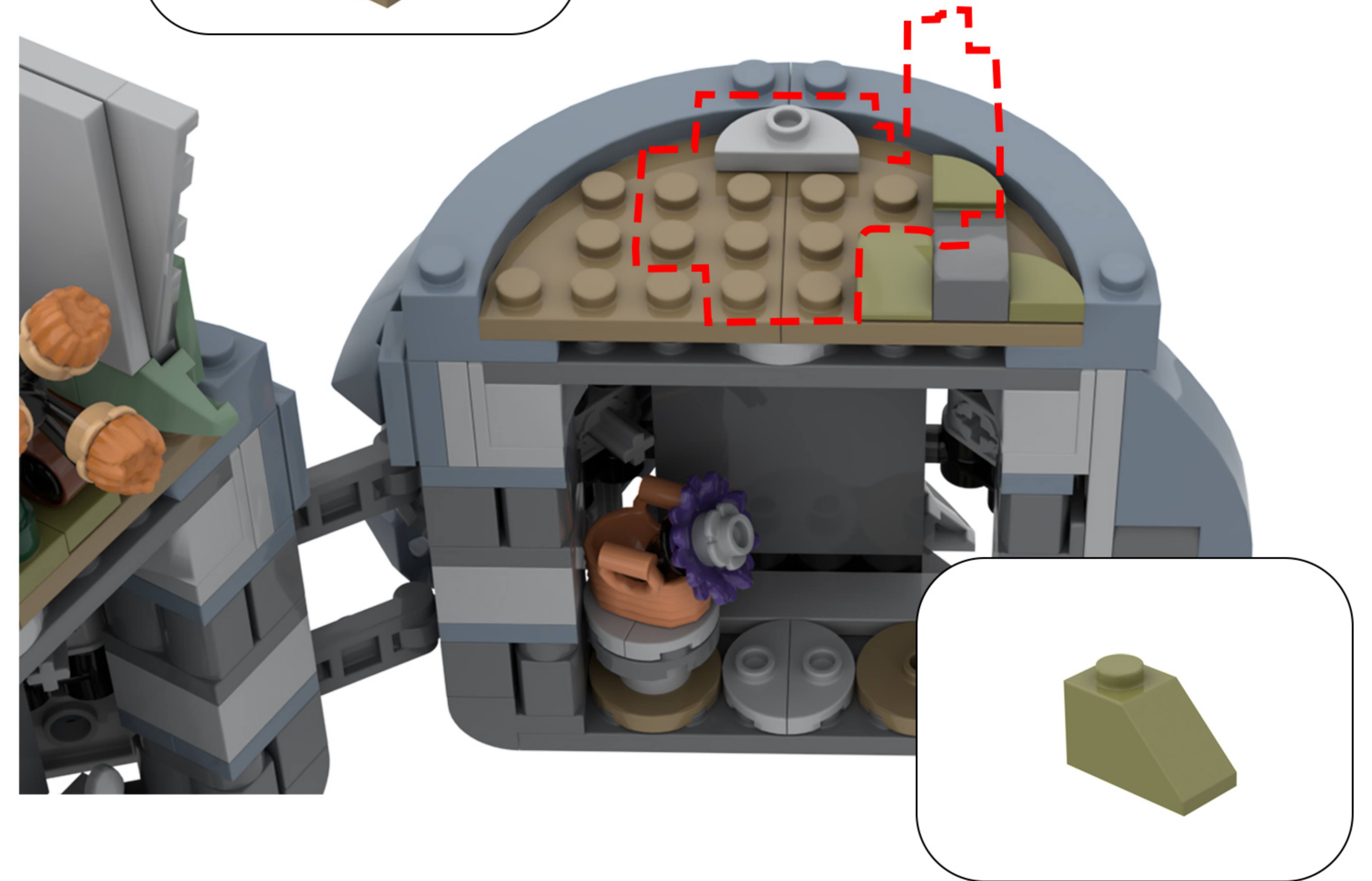
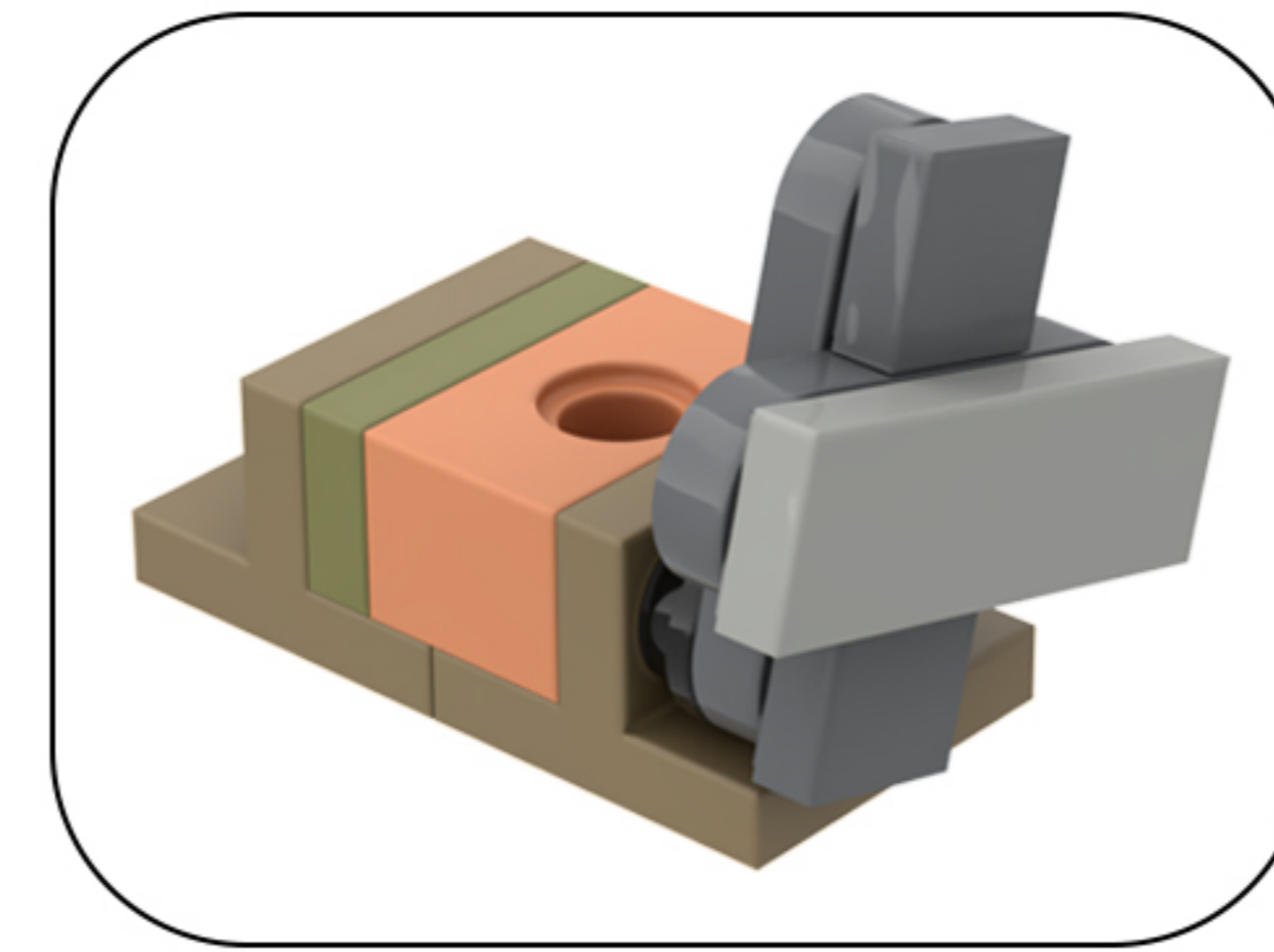

39

EN: Take the disassembled building block and attach it to the building block where you just installed the lights.

DE: Nimm den zerlegten Baustein und befestige ihn an dem Baustein, an dem du gerade die Lichter angebracht hast.

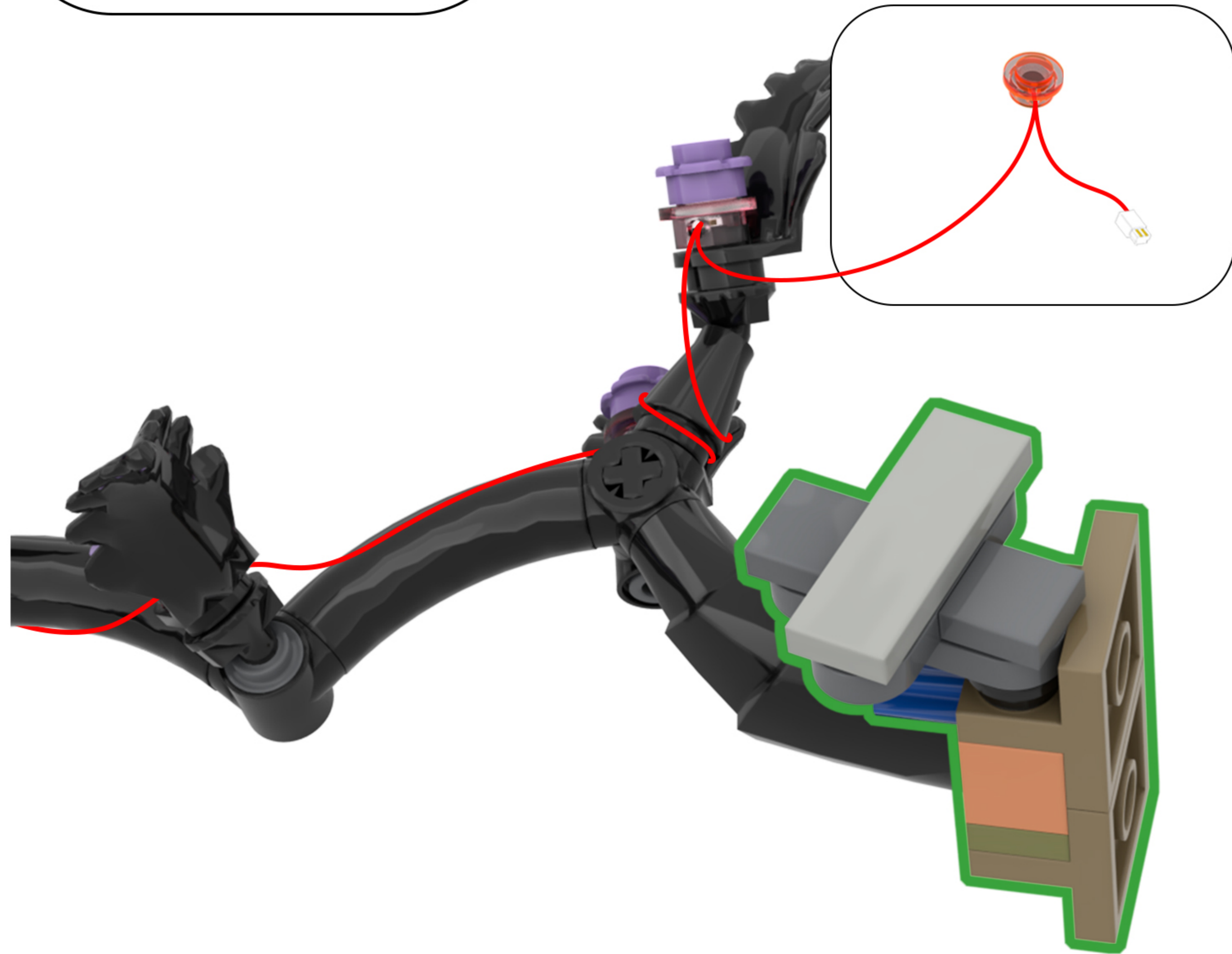
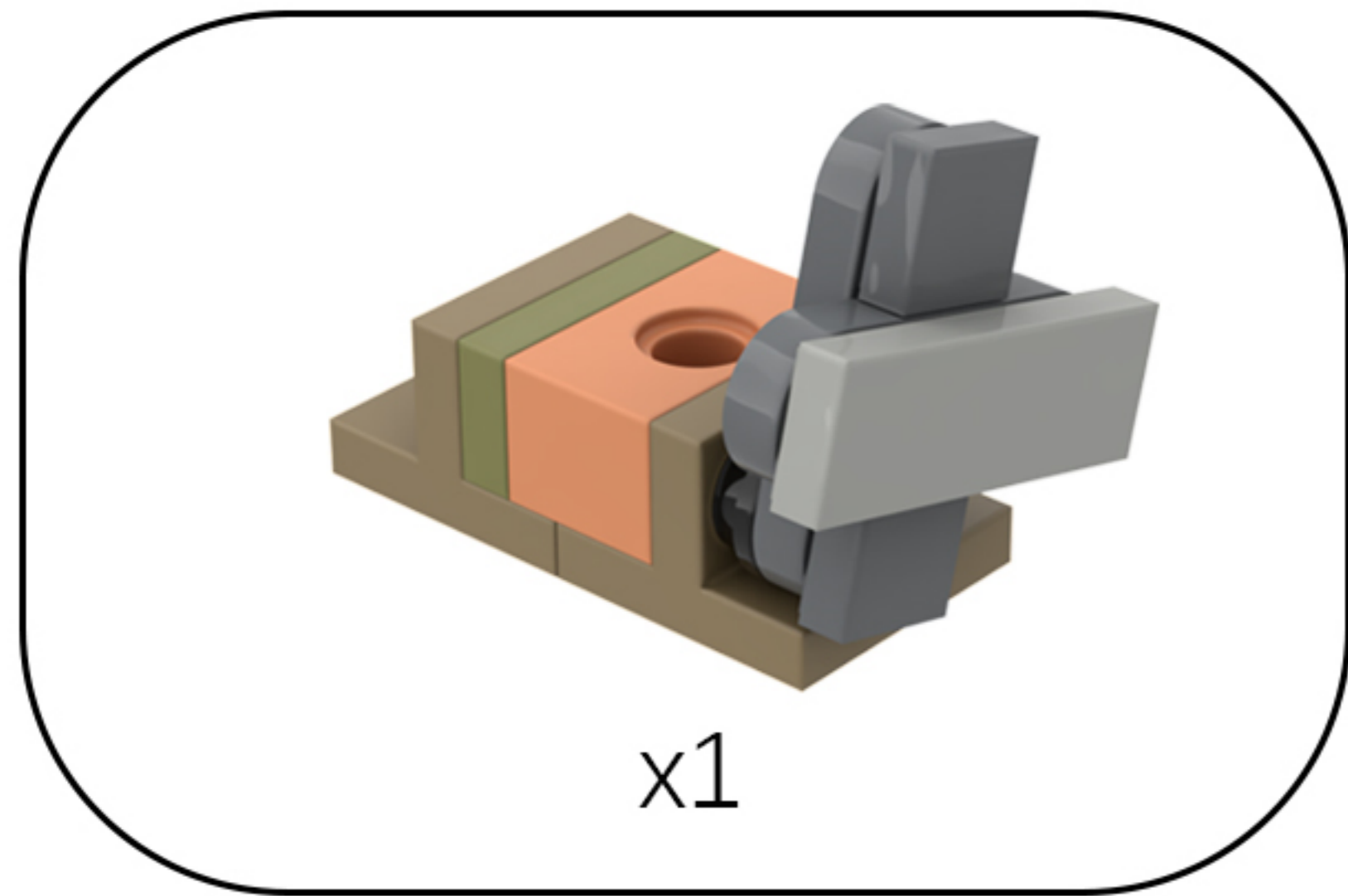

40

EN: Restore the building blocks.

DE: Stellen Sie die Bausteine wieder her.

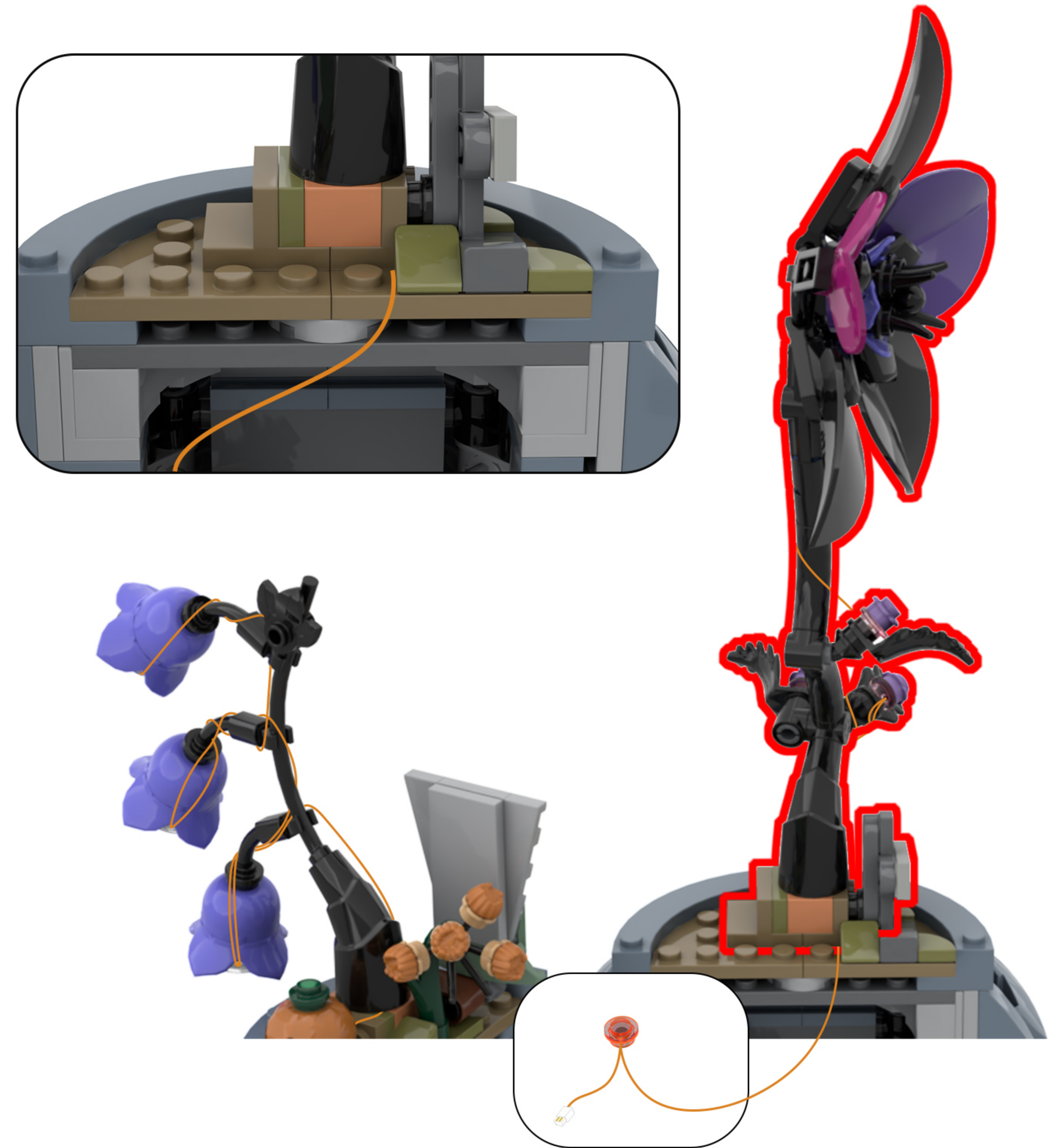

Note: When reassembling, use the bottom block to secure the light cord.

41

EN: Take out the disassembled building blocks, reassemble them, and secure the light cord.

DE: Nehmen Sie die zerlegten Bausteine heraus, setzen Sie sie wieder zusammen und befestigen Sie das Lichtkabel.

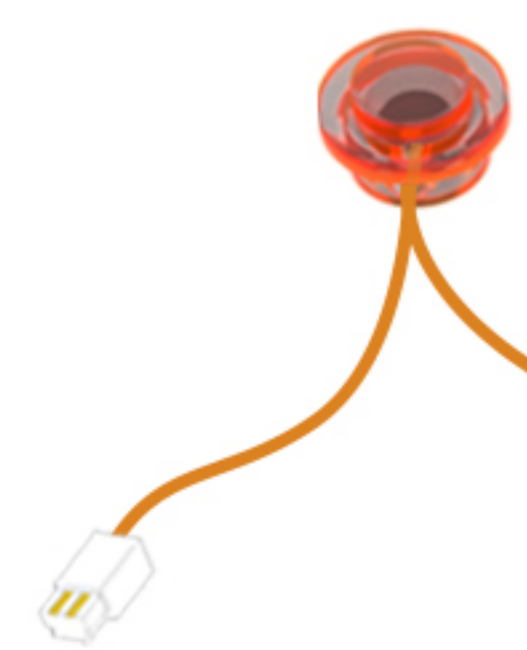
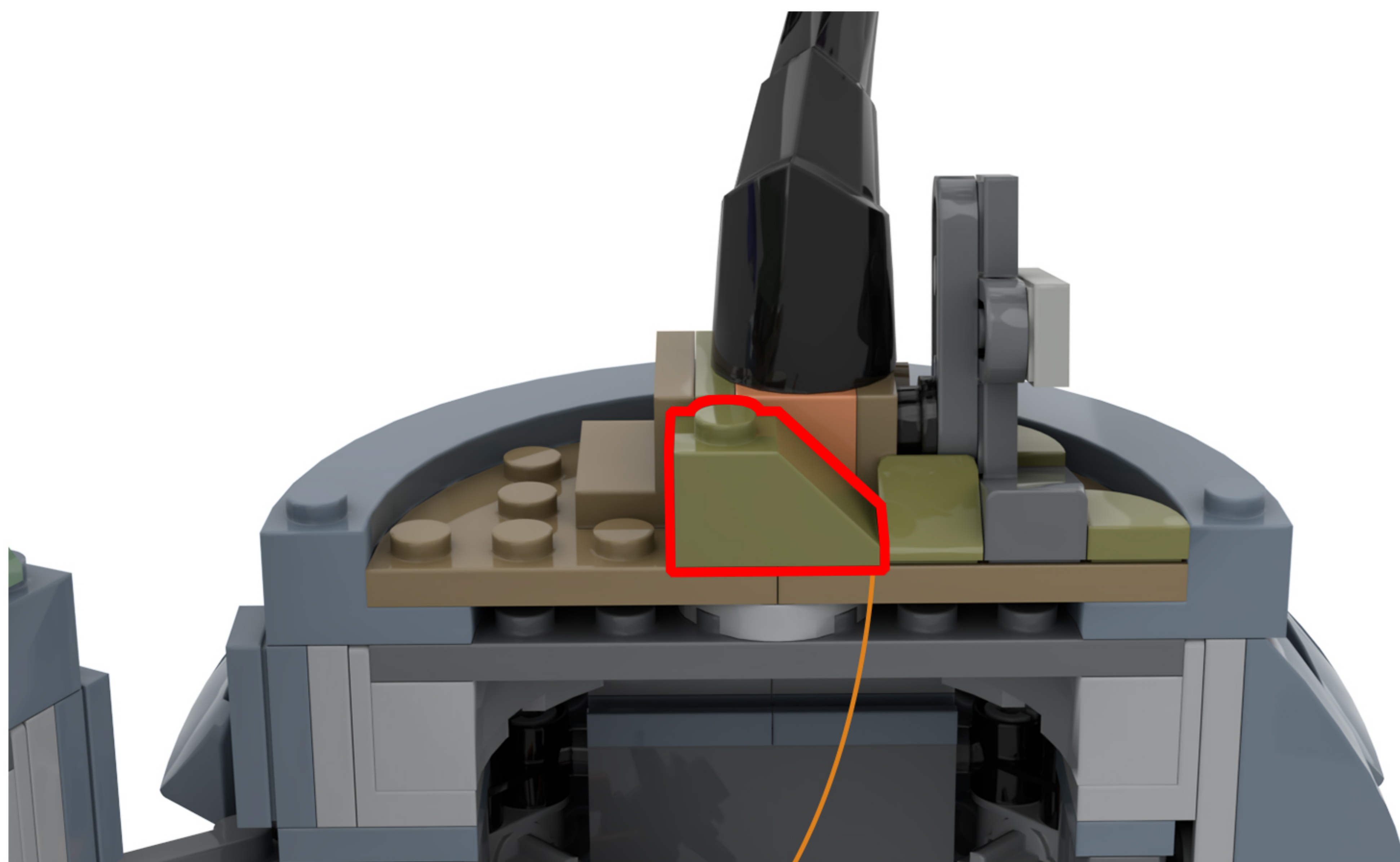
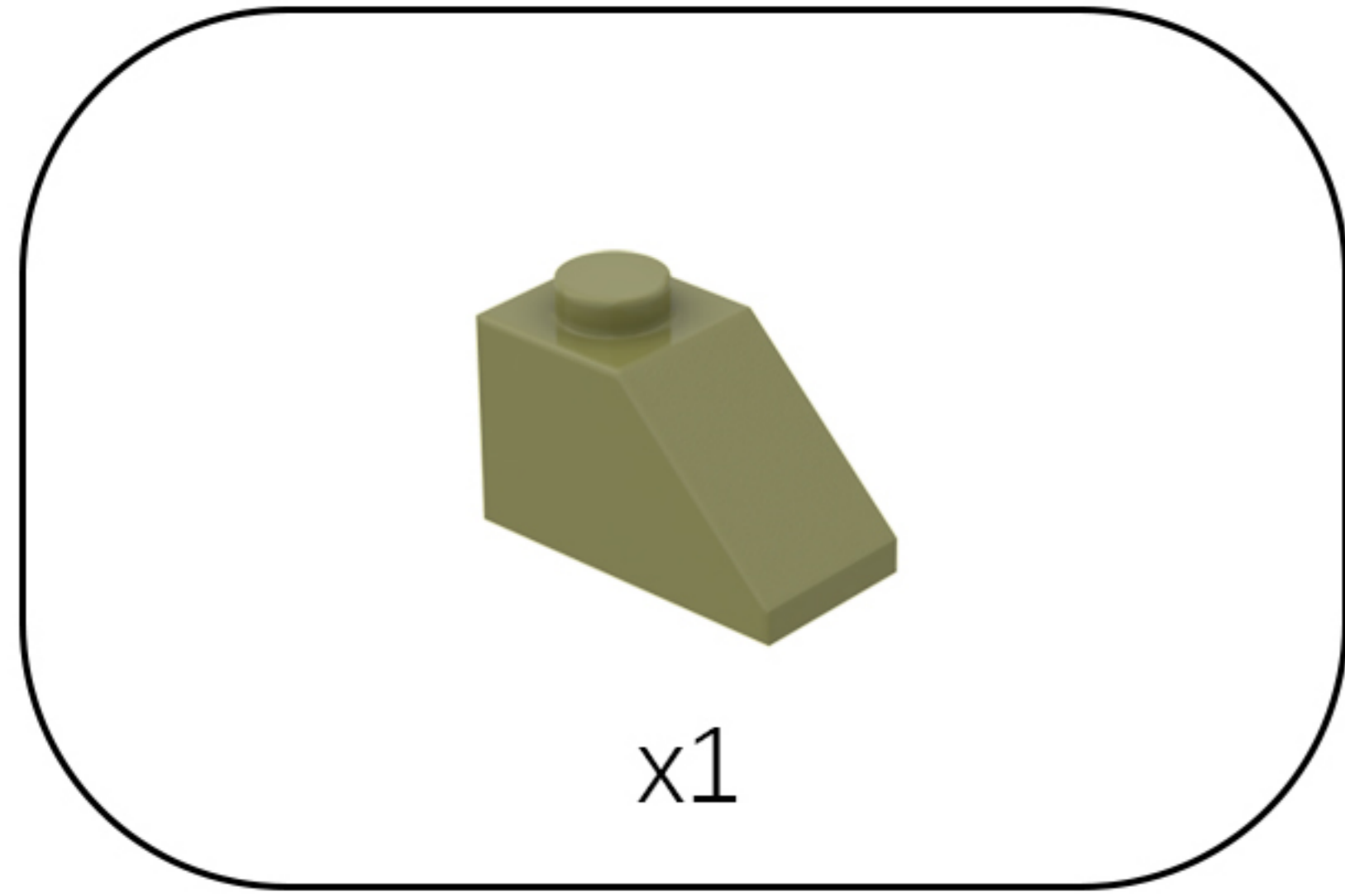

42

EN: Find the lights in the string of lights.

DE: Finde die Lichter in der Lichterkette.

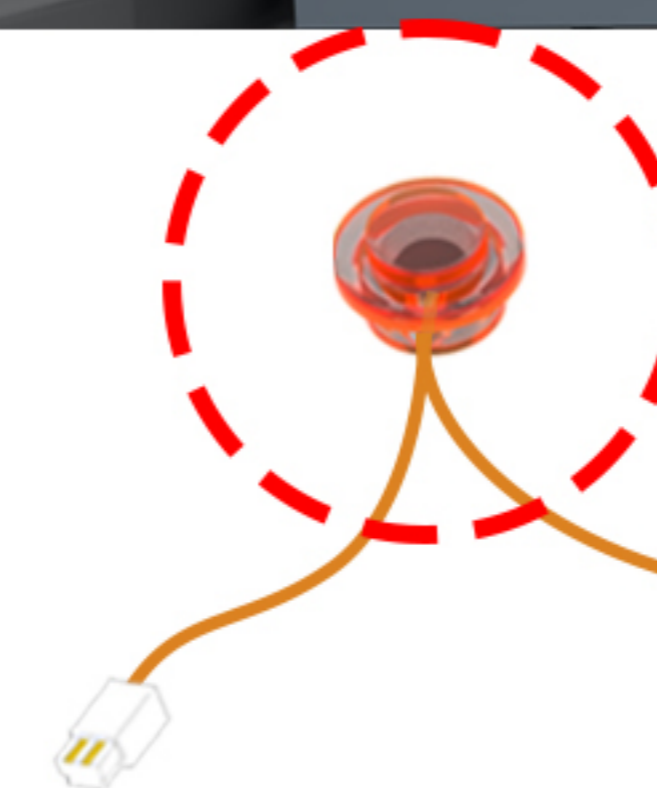
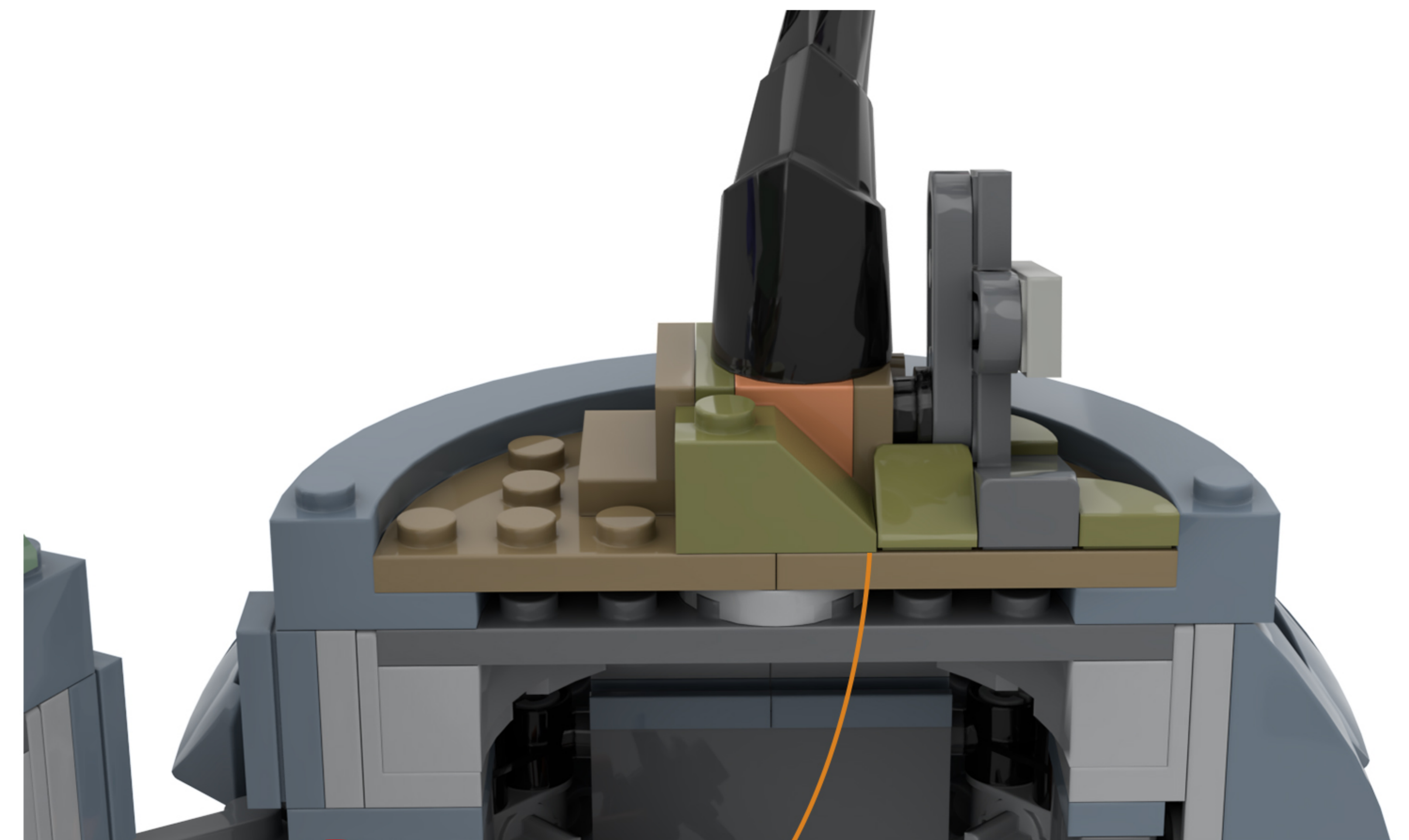

43 EN: Install the light fixture onto the building block.
DE: Installieren Sie die Leuchte auf dem Baustein.

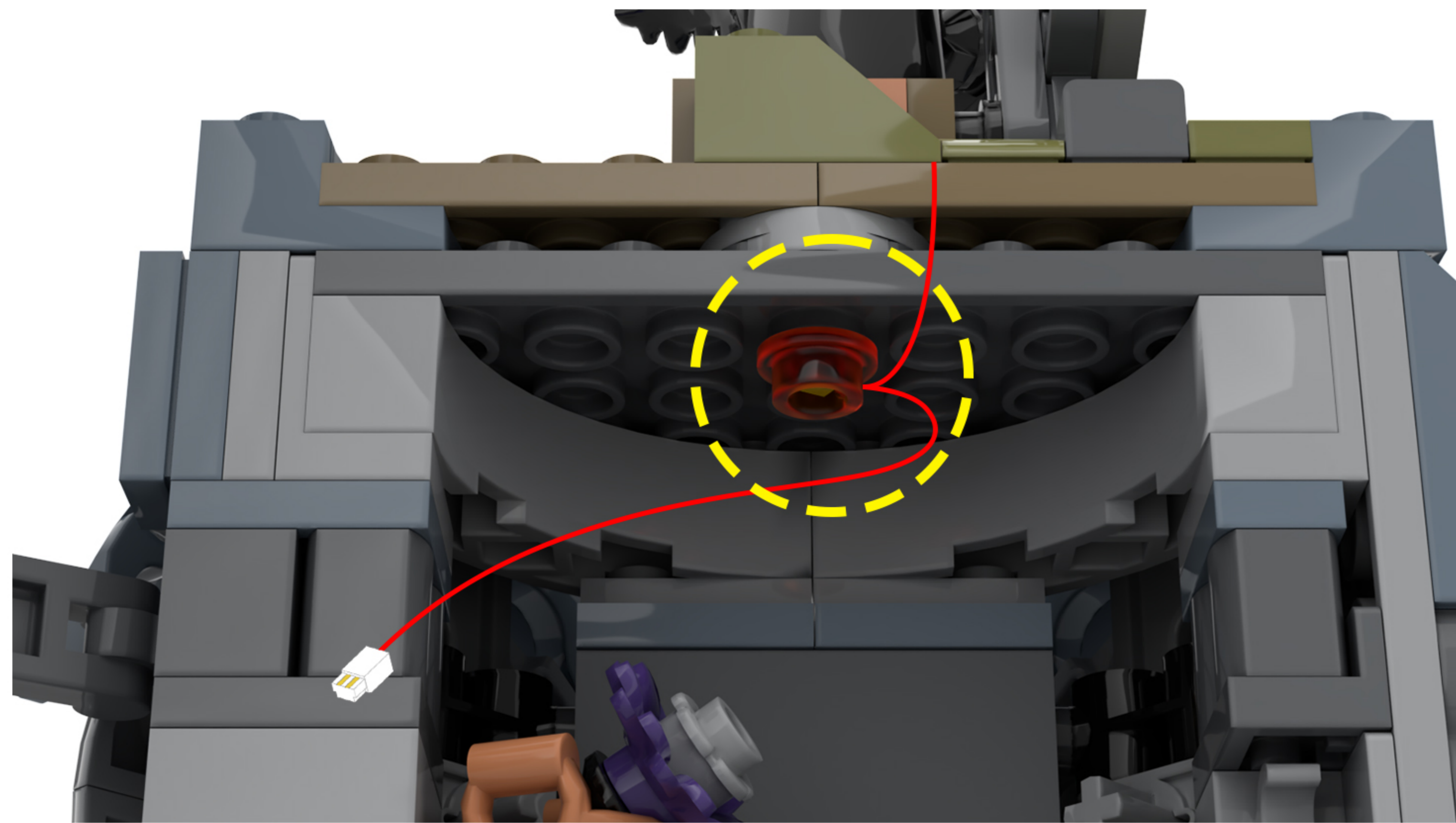

44 EN: Locate the two light wires in the diagram.
DE: Suchen Sie die beiden Lichtkabel in der Abbildung.

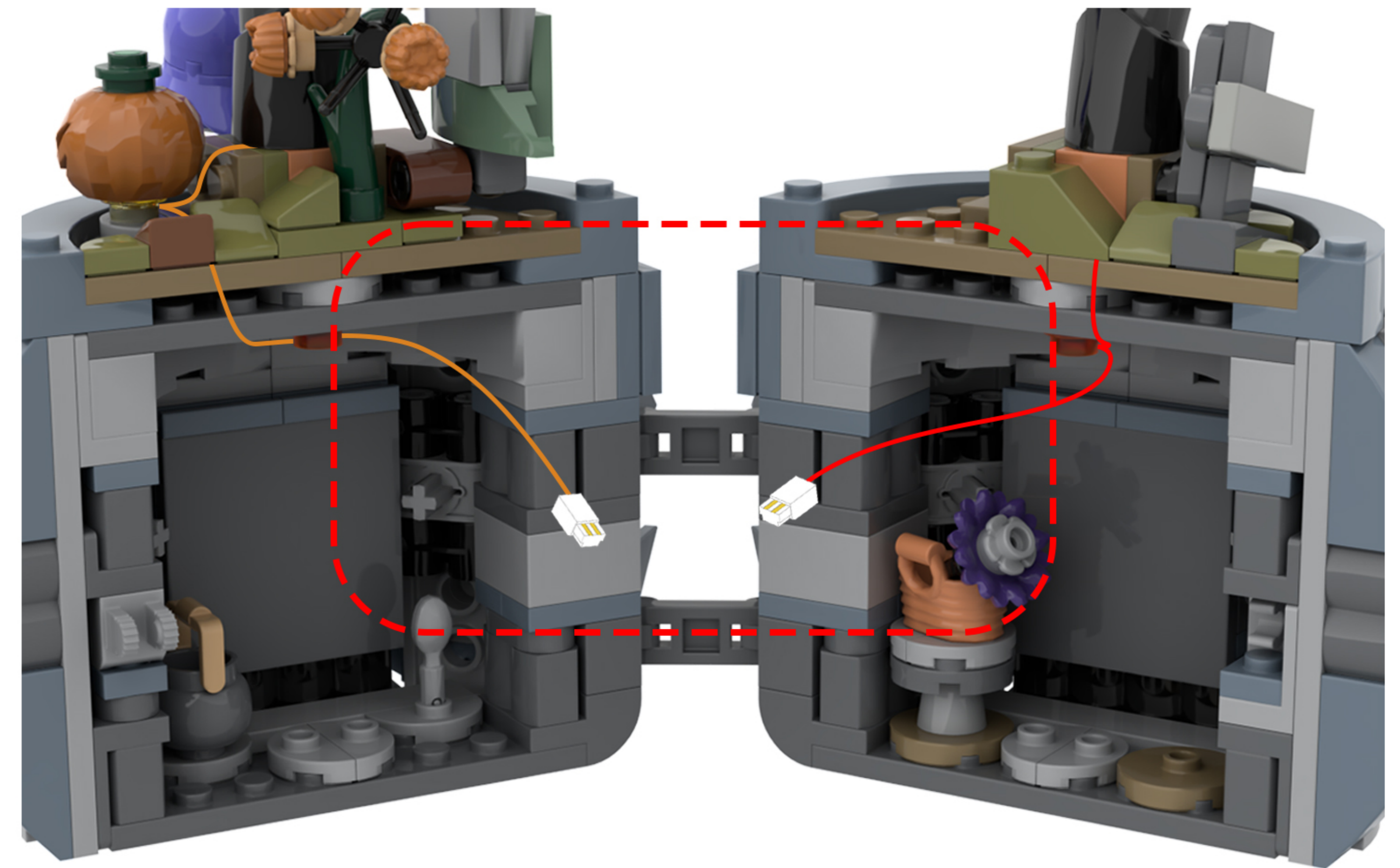

45

EN: Take the expansion board out of Bag 2 and connect the two light wires to the expansion board one after the other.

DE: Nehmen Sie die Erweiterungsplatine aus Beutel 2 und schließen Sie die beiden Lichtkabel nacheinander an die Erweiterungsplatine an.

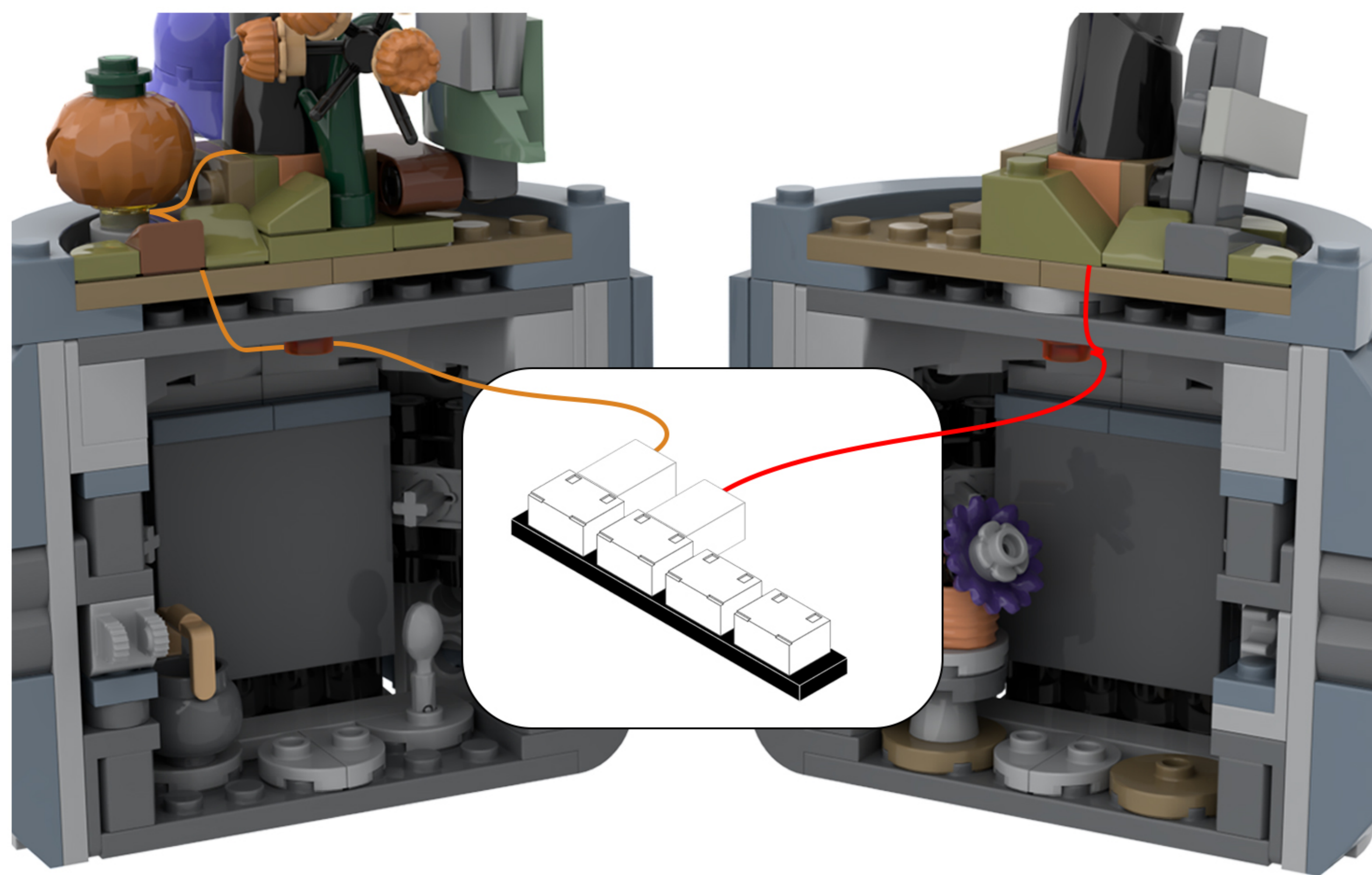
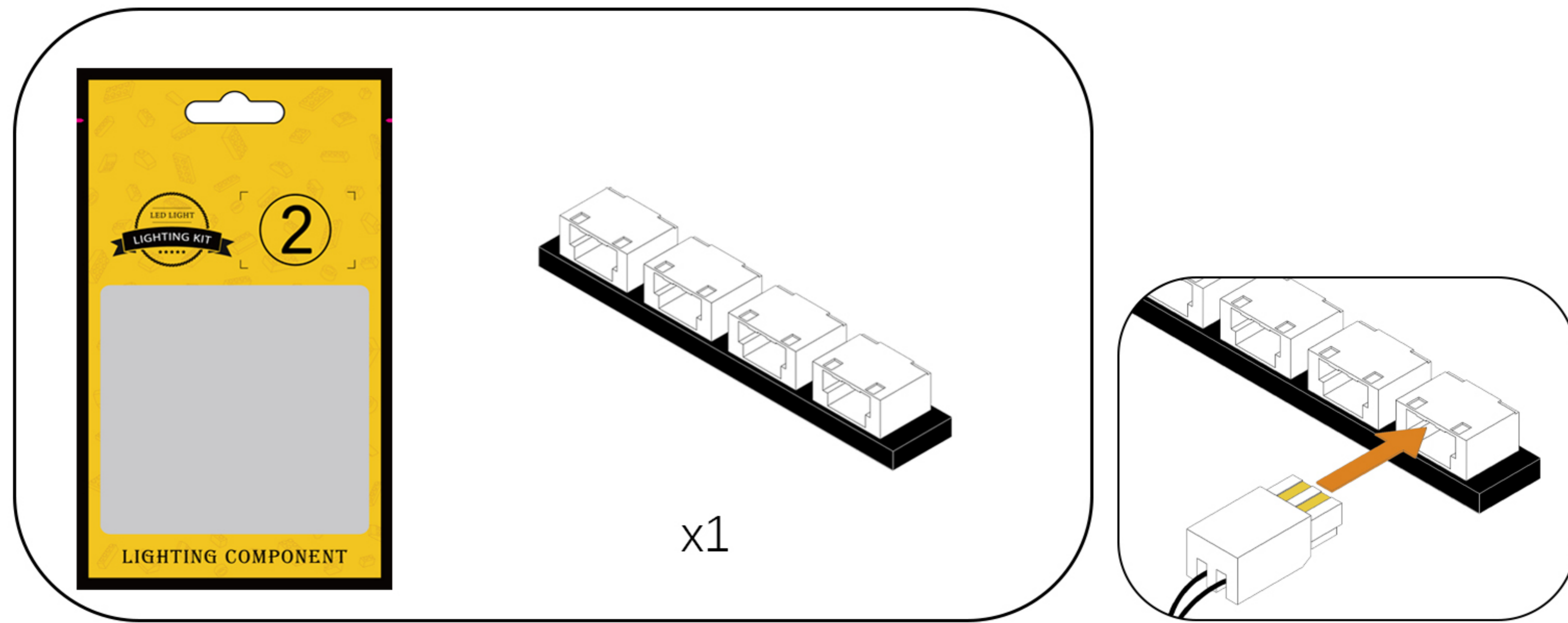

46

EN: Remove the USB power cable from the bag and connect it to the expansion board.

DE: Entnehmen Sie das USB-Stromkabel aus der Tasche und schließen Sie es an die Erweiterungskarte an.

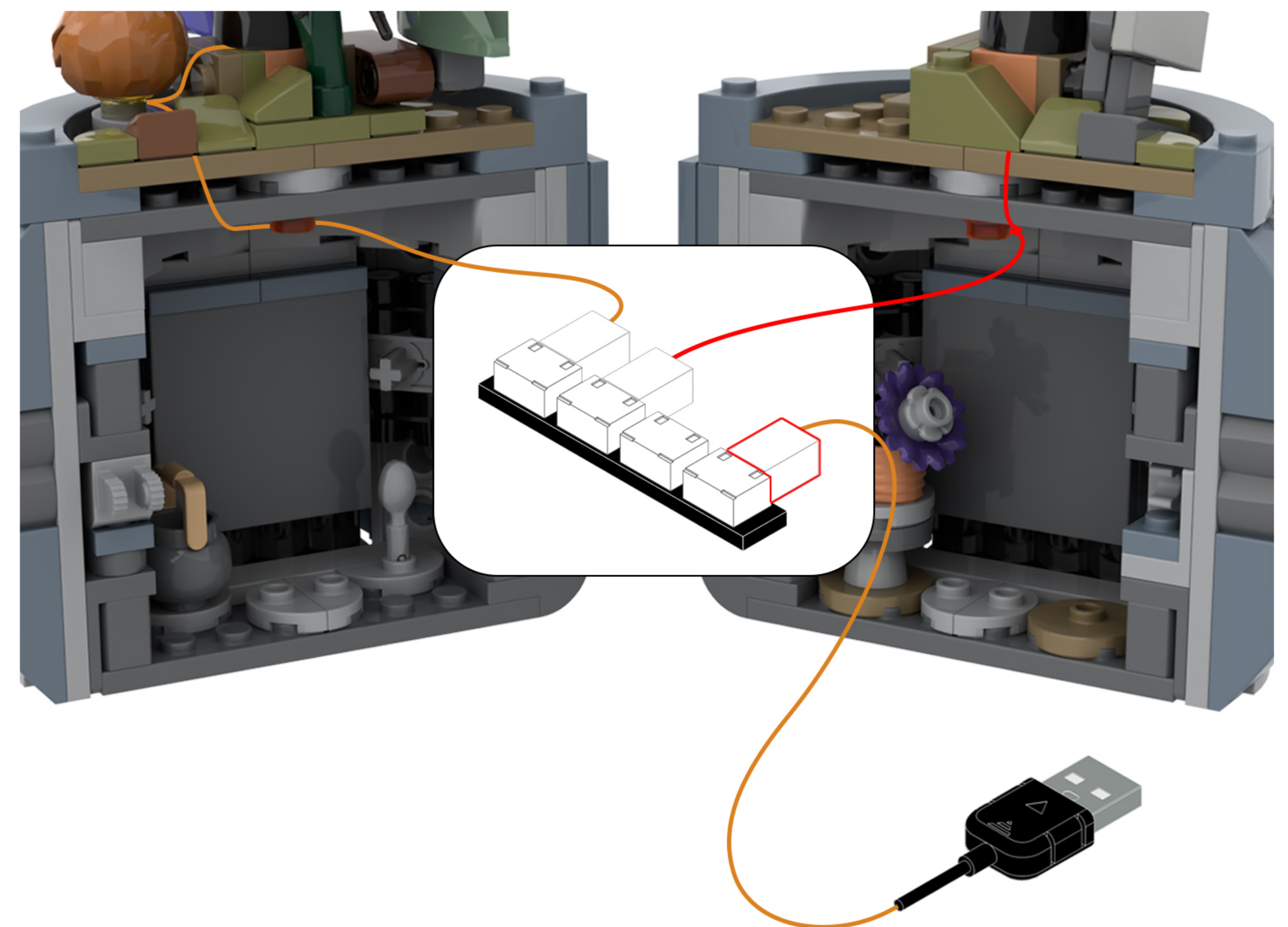
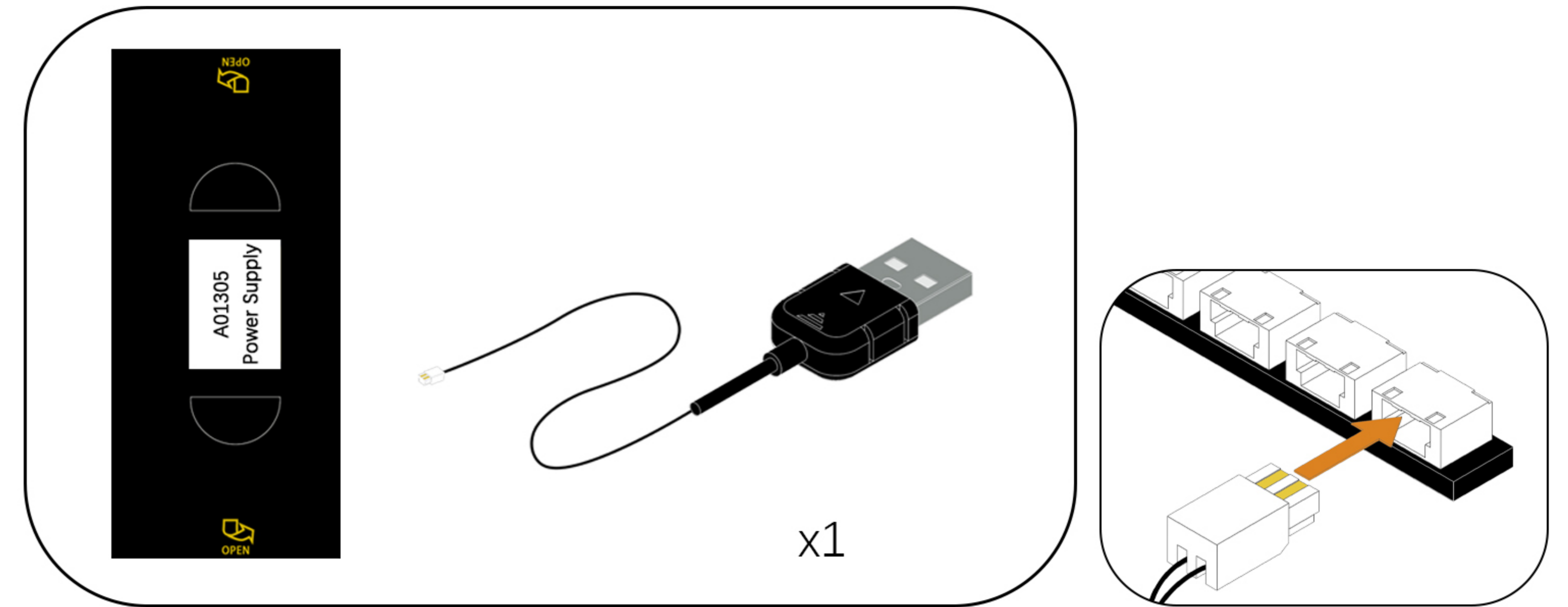

47

EN: Peel off the adhesive backing of the expansion board and attach it to the location shown in the illustration.

DE: Entfernen Sie die Schutzfolie von der Rückseite der Erweiterungsplatte und kleben Sie sie an die in der Abbildung gezeigte Stelle.

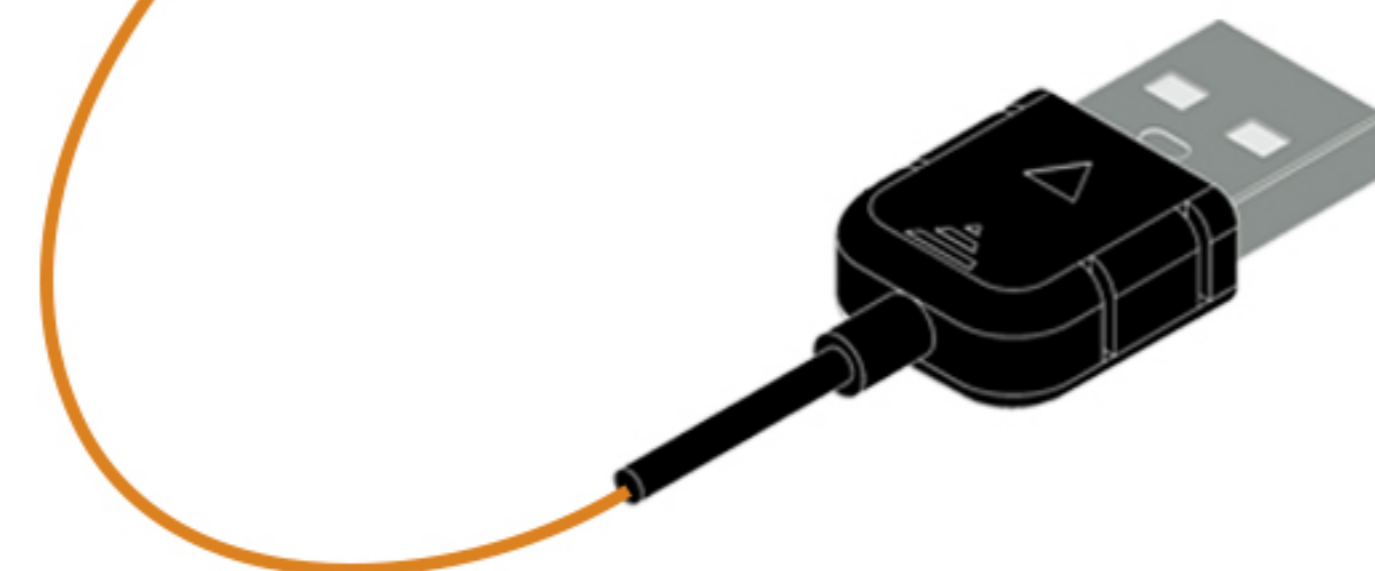
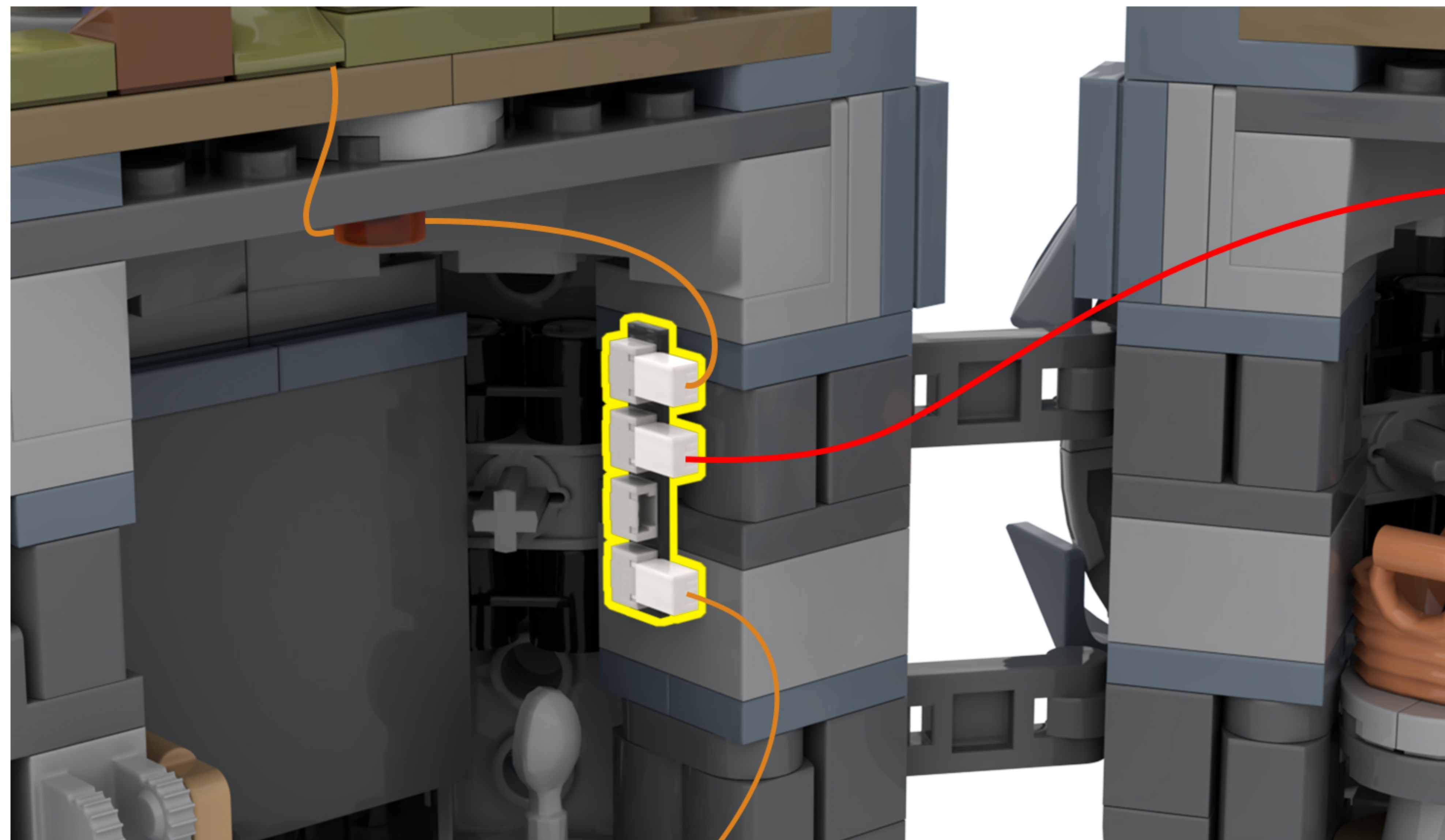

48

EN: Snap the two blocks together.

DE: Stecken Sie die beiden Blöcke zusammen.



49

EN: Once installed, connect the power supply and give it a try!

DE: Die Installation ist abgeschlossen. Schließen Sie das Gerät an die Stromversorgung an und probieren Sie es aus!





Above our designers to provide the relevant ideas and instructions. But please move to the following:

- 1: about our company this product parts material, product quality do you have comments and suggestions?
- 2: about this product installation instructions and installation of the degree of difficulty do you have views and suggestions?
- 3: if in the operation of the product we provide ideas encountered any problems, please contact us in a timely manner.

Tips

If you encounter any installation problems please contact the seller, we will be happy to help you solve!